

THIS DRAWING IS UNPUBLISHED. RELEASED FOR PUBLICATION
 BY AMP INCORPORATED. ALL RIGHTS RESERVED.

LOC	DIST	REVISIONS					
		P	LTR	DESCRIPTION	DATE	DWN	APVD
G	14			RELEASED PER PR 96-42	30MAY96	DKS	MJS

AMP WIRE RANGE	UL E13288 Listed
16-14HD AWG SOLID OR STRANDED	PENDING
SR LR7189 Certified	MILITARY P/N AND CLASS
16-14HD AWG SOLID OR STRANDED	NOT APPLICABLE

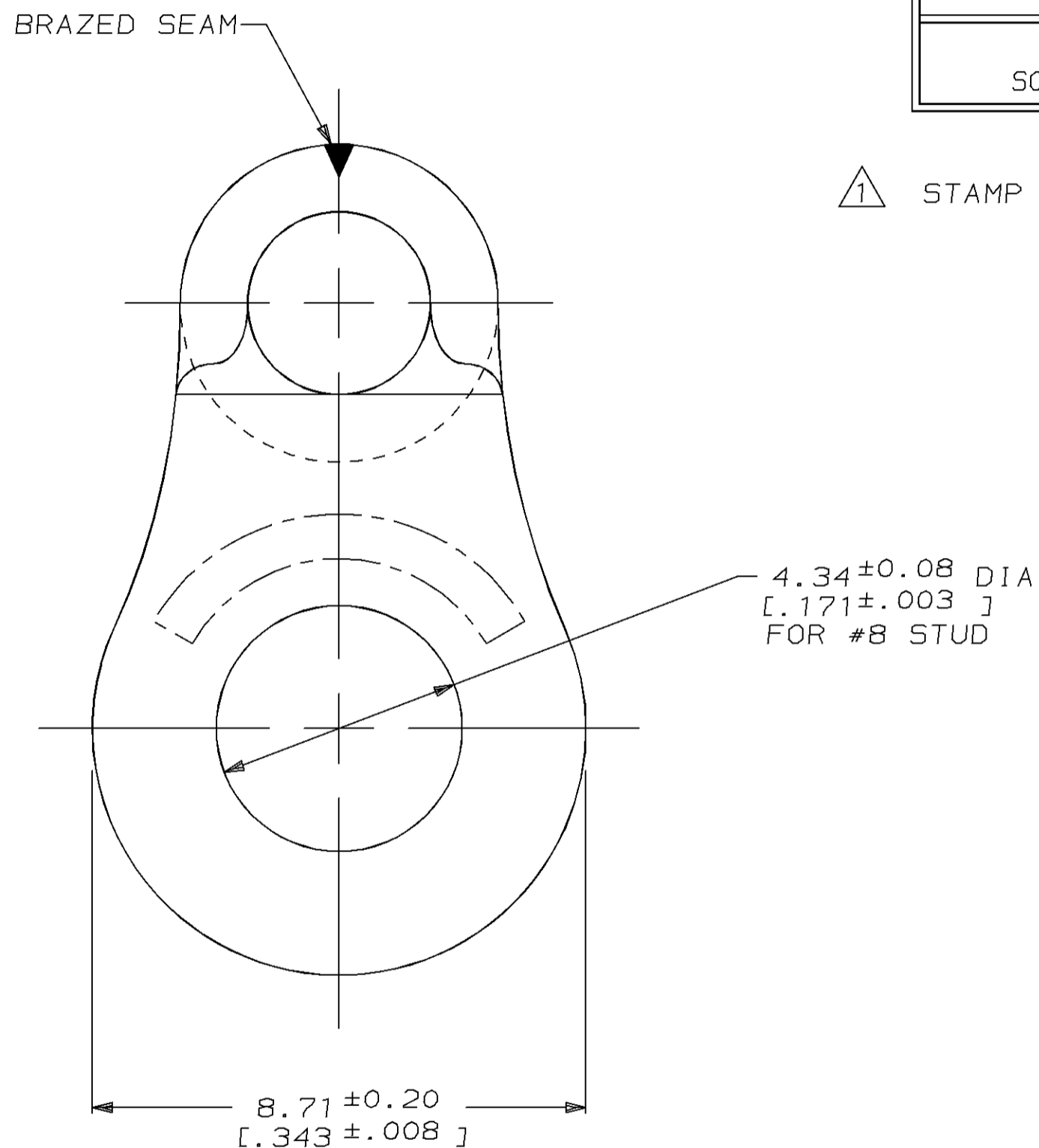
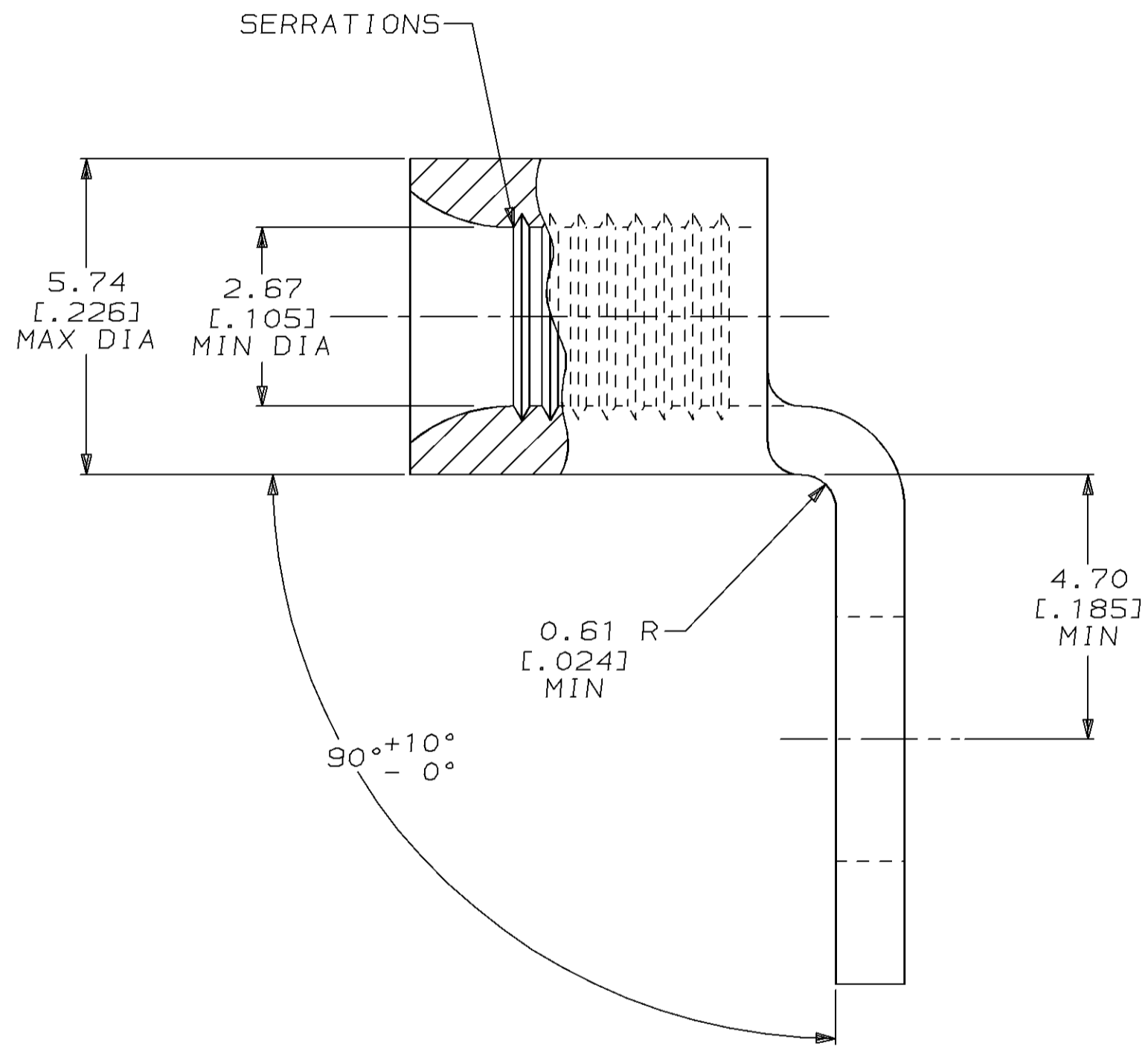

△ STAMP AMP 16-14HD* APPROX AS SHOWN

184269-1
AMP
PART NUMBER

AMP INCORPORATED CUSTOMER SERVICE SYSTEMS		RECOMMENDED OPERATING TEMPERATURE: 170°C MAX
FOR ADDITIONAL PRODUCT INFORMATION OR COPIES OF DRAWINGS AND TECHNICAL DOCUMENTS	PRODUCT INFORMATION CENTER 1-800-522-6752	VOLTAGE RATING: NOT APPLICABLE
FOR APPLICATION TOOLING INFORMATION	TOOLING ASSISTANCE CENTER 1-800-722-1111	WIRE CROSS SECTIONAL AREA RANGE: 1.04-2.62mm ² [2,050-5,180] CIR MILS SOLID OR STRANDED
FOR ORDER ENTRY	1-800-526-5142	

THIS DRAWING IS A CONTROLLED DOCUMENT FOR AMP INCORPORATED. IT IS SUBJECT TO CHANGE AND THE CONTROLLING ENGINEERING ORGANIZATION SHOULD BE CONTACTED FOR THE LATEST REVISION.		DWN DK SCHRUM 30MAY96	AMP AMP Incorporated Harrisburg, PA 17105-3608	
DIMENSIONS: mm [INCHES]	TOLERANCES UNLESS OTHERWISE SPECIFIED:	CHK MJ SPICER 31MAY96	NAME TERMINAL, RING TONGUE, SOLISTRAND™, WIRE SIZE: 16-14HD AWG	
	0 PLC ±- 1 PLC ±- 2 PLC ±- 3 PLC ±- 4 PLC ±- ANGLES ±-	APVD JL MECKLEY 31MAY96	SIZE A2	CAGE CODE 00779
MATERIAL COPPER PER ASTM B-152 ANNEALED	FINISH TIN PLATE 0.00254 [0.001003] MIN THK PER MIL-T-10727	PRODUCT SPEC - APPLICATION SPEC -	WEIGHT -	DRAWING NO C=184269
CUSTOMER DRAWING			SCALE 10:1	SHEET 1 OF 1
			REV 0	

184269