

| PART NUMBER | REV | FIRST USED |
|-------------|-----|------------|
| 680299-1 | 0 | 122500-1 |
| 680299-2 | 0 | 565435-5 |

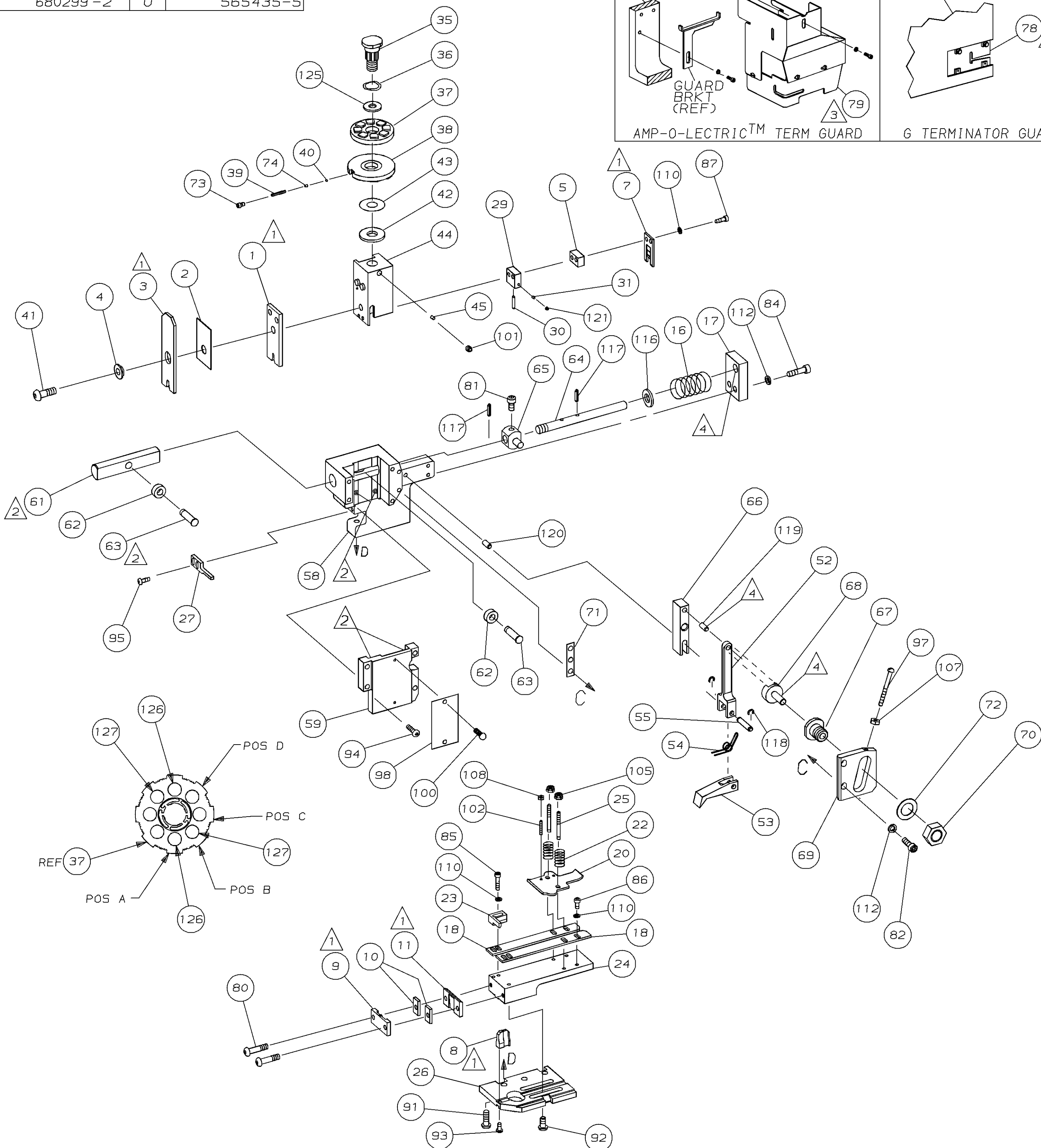
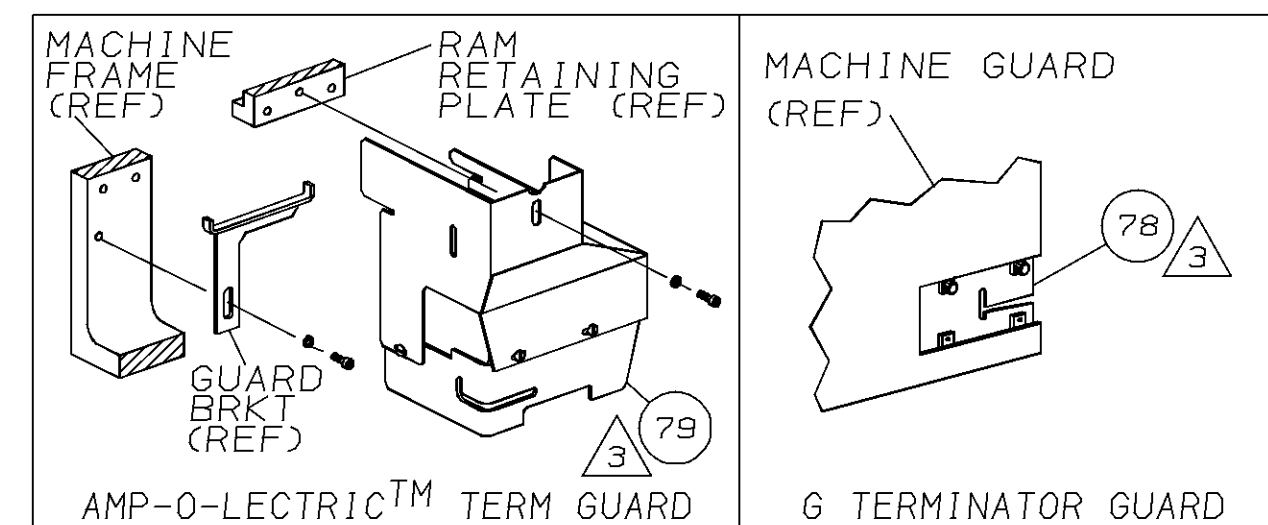

| TERMINAL NAME: SNAP-IN CLUSTER RECEPTACLE | | CRIMPING DATA | |
|---|---------------------------|---------------|------------|
| PAD LTR | CRIMP HEIGHT | WIRE SIZE | |
| A | .065 ±.002 [1.65 ±0.05mm] | 16 | |
| B | .058 ±.002 [1.47 ±0.05mm] | 18 | |
| C | NOT | USED | |
| D | NOT | USED | |
| CRIMP | SIZE | TYPE | RANGE |
| WIRE | .090 [2.29mm] | F | 18-16 |
| INSUL | .140 [3.56mm] | F | ∅.135-.160 |

| QTY | REF | REV | U/M | DWG SIZE | PART NO | DESCRIPTION | ITEM NO |
|-----|-----|-----|-----|----------|------------|-------------------------------------|---------|
| 129 | | | | | | | 129 |
| 128 | | | | | | | 128 |
| 2 | 2 | - | C | | 354779-6 | PIN, WIRE DISC (.3020)B | 127 |
| 2 | 2 | - | C | | 9-354778-1 | PIN, WIRE DISC (.2950)A | 126 |
| 1 | 1 | - | A | | 986950-1 | WASHER, FLAT PRECISION | 125 |
| 1 | 1 | - | A | | 217238-1 | DOCUMENTATION PACKAGE | 124 |
| 1 | 1 | - | - | | 4088039 | EF APPL INST 408-8039 | 123 |
| | | | | | | | 122 |
| 1 | 1 | - | A | | 1-21006-7 | SCR, SKT SET (2-56x.19) FORMING PIN | 121 |
| REF | REF | - | A | | 1-21030-7 | PIN, DOWEL (∅.187x1.50) HSG | 120 |
| REF | REF | - | A | | 1-21030-1 | PIN, DOWEL (∅.187x.50) LEVER | 119 |
| REF | REF | - | A | | 21045-3 | RING, RET "C" (∅.187) FD PIN | 118 |
| REF | REF | - | A | | 5-21028-1 | PIN, STD SPRING (∅.12) FD ADJ ROD | 117 |
| REF | REF | - | A | | 21899-4 | WASHER, FLAT (∅5/16) SCR ADJ | 116 |
| | | | | | | | 115 |
| | | | | | | | 114 |
| | | | | | | | 113 |
| REF | REF | - | A | | 21024-5 | WASHER, LOCK (NO. 10) FD ROD GDE | 112 |
| 7 | 7 | - | A | | 21024-4 | WASHER, LOCK (NO. 8) SHEAR BL | 110 |
| | | | | | | | 109 |
| 2 | 2 | - | A | | 21018-4 | NUT, HEX (4-40) DRAG | 108 |
| REF | REF | - | A | | 21018-5 | NUT, HEX (6-32) FD ADJ PL | 107 |
| | | | | | | | 106 |
| 2 | 2 | - | A | | 21022-2 | NUT, HEX SL (8-32) DRAG STUD | 105 |
| | | | | | | | 104 |
| | | | | | | | 103 |
| 2 | 2 | - | A | | 2-21006-6 | SCR, SKT SET (4-40x.62) DRAG | 102 |
| 1 | 1 | - | A | | 21009-2 | SCR, SKT SET (1/4-20x.25) RAM | 101 |
| 2 | 2 | - | A | | 21017-2 | SCR, DRIVE (#2x.19) ID PLATE | 100 |
| 1 | 1 | - | A | | 1-21002-7 | SCR, BHC (6-32x.38) CAM | 99 |
| 1 | 1 | - | B | | 461264-1 | PLATE, IDENTIFICATION | 98 |
| REF | REF | - | A | | 6-23715-5 | SCR, PAN HD (6-32x1.50) FEED ADJ | 97 |
| | | | | | | | 96 |
| 2 | 2 | - | A | | 2-21002-2 | SCR, BHC (8-32x.50) STRIPPER | 95 |
| REF | REF | - | A | | 2-21002-9 | SCR, BHC (10-32x.75) HSG CAP | 94 |
| 1 | 1 | - | A | | 22733-8 | SCR, BHC (8-32x.38 LW) ANVIL | 93 |
| 4 | 4 | - | A | | 3-21002-3 | SCR, BHC (1/4-20x.50) ST 6D PL | 92 |
| REF | REF | - | A | | 2-22733-8 | SCR, BHC (1/4-20x.62) BASE PL | 91 |
| | | | | | | | 90 |
| | | | | | | | 89 |
| | | | | | | | 88 |
| 2 | 2 | - | A | | 2-21000-7 | SCR, SHC (8-32x.50) SLUG BLADE | 87 |
| 3 | 3 | - | A | | 2-21000-6 | SCR, SHC (8-32x.38) STRIP GUIDE | 86 |
| 2 | 2 | - | A | | 2-21000-9 | SCR, SHC (8-32x.75) R STRIP GUIDE | 85 |
| REF | REF | - | A | | 3-21000-7 | SCR, SHC (10-32x.75) FEED ROD GDE | 84 |
| | | | | | | | 83 |
| REF | REF | - | A | | 3-21000-6 | SCR, SHC (10-32x.62) FEED ADJ PL | 82 |
| REF | REF | - | A | | 3-21000-4 | SCR, SHC (10-32x.38) PIVOT BLOCK | 81 |
| 2 | 2 | - | A | | 3-21002-0 | SCR, BHC (10-32x.88) SHEAR PL | 80 |
| REF | - | - | A | | 455745-1 | GUARD, WINDOW | 79 |
| - | REF | - | A | | 679532-1 | INSERT, GUARD | 78 |
| | | | | | | | 77 |
| | | | | | | | 76 |
| | | | | | | | 75 |
| 1 | 1 | - | A | | 690603-1 | SPRING, ASSIST | 74 |
| 1 | 1 | - | A | | 23030-1 | SCR, SKT CAP (6-32x.25) CP DSC | 73 |
| REF | REF | - | A | | 458109-1 | WASHER, FLAT (SPECIAL) | 72 |
| REF | REF | - | A | | 690517-1 | SPACER | 71 |

| QTY | REF | REV | U/M | DWG SIZE | PART NO | DESCRIPTION | ITEM NO |
|-----|-----|-----|-----|----------|------------|------------------------------|---------|
| | | | | | | | 70 |
| | | | | | | | 69 |
| | | | | | | | 68 |
| | | | | | | | 67 |
| | | | | | | | 66 |
| | | | | | | | 65 |
| | | | | | | | 64 |
| | | | | | | | 63 |
| | | | | | | | 62 |
| | | | | | | | 61 |
| | | | | | | | 60 |
| | | | | | | | 59 |
| | | | | | | | 58 |
| | | | | | | | 57 |
| | | | | | | | 56 |
| | | | | | | | 55 |
| | | | | | | | 54 |
| | | | | | | | 53 |
| | | | | | | | 52 |
| | | | | | | | 51 |
| | | | | | | | 50 |
| | | | | | | | 49 |
| 1 | - | - | B | | 690501-3 | CAM, POST FEED 1 1/8 ST | 48 |
| - | 1 | - | B | | 690501-4 | CAM, POST-FEED 1 5/8 ST | 47 |
| | | | | | | | 46 |
| 1 | 1 | - | A | | 690191-1 | PLUG, NYLON | 45 |
| 1 | 1 | - | C | | 455674-2 | RAM | 44 |
| 1 | 1 | - | A | | 690125-1 | WASHER, LAMINATED | 43 |
| 1 | 1 | - | A | | 690124-1 | WASHER, RAM | 42 |
| 1 | 1 | - | A | | 7-21002-9 | BOLT, CRIMPER (5/16-24x1.00) | 41 |
| 1 | 1 | - | A | | 23241-6 | BALL, STEEL | 40 |
| 1 | 1 | - | A | | 690170-1 | SPRING, COMPRESSION | 39 |
| 1 | 1 | - | C | | 690142-1 | DISC, INSULATION | 38 |
| 1 | 1 | - | D | | 354777-1 | WIRE DISC, PLASTIC | 37 |
| 1 | 1 | - | A | | 22480-5 | WASHER, SPRING | 36 |
| 1 | 1 | - | B | | 690212-1 | POST, RAM | 35 |
| | | | | | | | 34 |
| | | | | | | | 33 |
| 1 | 1 | - | D | | 458980-2 | APPLICATOR, BASIC (SUB ASSY) | 32 |
| 1 | 1 | - | A | | 690191-3 | PLUG, NYLON | 31 |
| 1 | 1 | - | A | | 692987-1 | PIN, FORMING | 30 |
| 1 | 1 | - | B | | 692986-1 | HOLDER, FORMING PIN | 29 |
| | | | | | | | 28 |
| 1 | 1 | - | A | | 690455-1 | STRIPPER | 27 |
| REF | REF | - | C | | 455676-1 | PLATE, BASE | 26 |
| 2 | 2 | - | A | | 22354-8 | DRAG, STUD | 25 |
| 1 | 1 | - | B | | 455678-3 | PLATE, STRIP GUIDE | 24 |
| 1 | 1 | - | C | | 240825-2 | PLATE, STRIP HOLD DOWN | 23 |
| 2 | 2 | - | A | | 4-22281-1 | SPRING, DRAG | 22 |
| | | | | | | | 21 |
| 1 | 1 | - | A | | 454177-1 | DRAG, STOCK | 20 |
| | | | | | | | 19 |
| 2 | 2 | - | C | | 454204-4 | GUIDE, STRIP (FRONT) | 18 |
| REF | REF | - | A | | 454178-1 | GUIDE, FEED ROD | 17 |
| REF | REF | - | A | | 4-22284-9 | SPRING, FEED RETURN | 16 |
| | | | | | | | 15 |
| | | | | | | | 14 |
| | | | | | | | 13 |
| | | | | | | | 12 |
| 1 | 1 | - | B | | 240644-5 | PLATE, REAR SHEAR | 11 |
| 2 | 2 | - | C | | 1-240645-0 | SPACER, SHEAR PLATE | 10 |
| 1 | 1 | - | B | | 690796-2 | PLATE, FRONT SHEAR | 9 |
| 1 | 1 | - | D | | 6-240655-0 | ANVIL | 8 |
| 1 | 1 | - | B | | 5-240651-2 | BLADE, SLUG | 7 |
| | | | | | | | 6 |
| 1 | 1 | - | C | | 240641-7 | SPACER, SLUG BLADE | 5 |
| 1 | 1 | - | B | | 238009-1 | SPACER, BLOCK CRIMPER | 4 |
| 1 | 1 | - | C | | 1-456134-4 | CRIMPER, INSULATION | 3 |
| 1 | 1 | - | B | | 455888-7 | SPACER, CRIMPER | 2 |
| 1 | 1 | - | C | | 1-456406-9 | CRIMPER, WIRE | 1 |

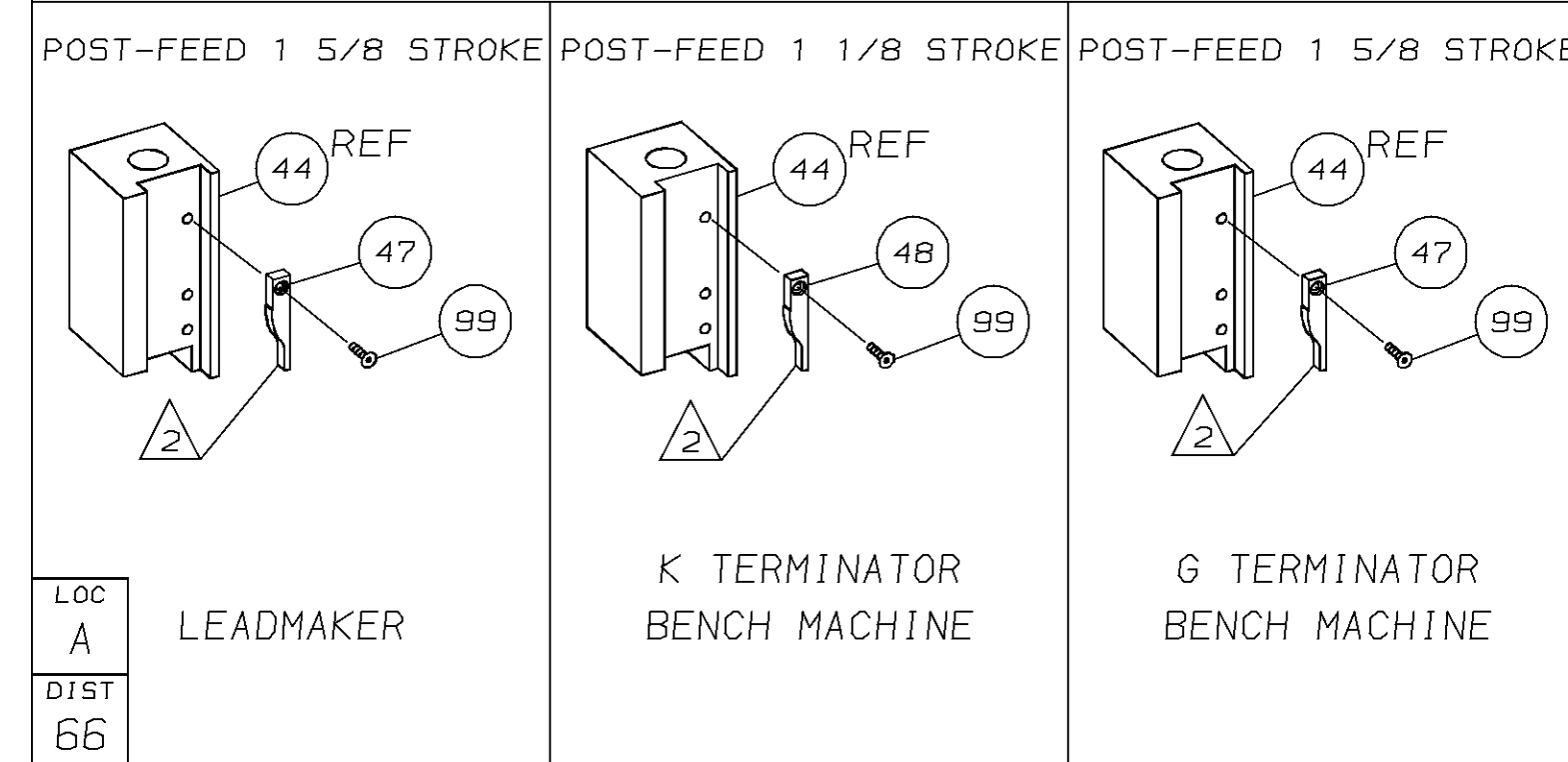

- 1 RECOMMENDED SPARE PARTS.
- 2 GREASE LIGHTLY.
- 3 GUARD MUST BE IN PLACE WHEN OPERATING APPLICATOR IN A BENCH MACHINE.
- 4 LUBRICATE DAILY USING NO. 20 MACHINE OIL.
- 5. ITEMS WITH QTY OF REF SPECIFIED (EXCEPT ITEMS 78 AND 79) ARE USED ON ITEM 32.
- 6 ITEM 78 USED WITH G TERMINATOR ONLY.
- 7 FEED OFF OF RECEPTACLE.
- 8 LANCE SUPPORT TO BE BENT DOWN .035-.045 IN APPLICATOR.

THIS DRAWING IS A CONTROLLED DOCUMENT FOR AMP INCORPORATED. IT IS SUBJECT TO CHANGE AND THE CONTROLLING ENGINEERING ORGANIZATION SHOULD BE CONTACTED FOR THE LATEST REVISION.

THIS INFORMATION IS CONFIDENTIAL AND IS DISCLOSED TO YOU ON CONDITION THAT NO FURTHER DISCLOSURE IS MADE BY YOU TO OTHER THAN AMP PERSONNEL WITHOUT WRITTEN AUTHORIZATION FROM AMP INCORPORATED, HARRISBURG, PA.

DIMENSIONS IN INCHES. DO NOT SCALE PRINT. TOLERANCES UNLESS OTHERWISE SPECIFIED.

DR M. OBRINE 4-8-96 APP T. ELBIN 4-8-96
 CHK 4-8-96 REL 5/8/96
 C. ERISMAN B. MORGAN

NAME: END FEED HDM APPLICATOR MACHINE REF: MINI APPL
 SCALE: 1 OF 1 REV: 0

REVISION RECORD: P/F LTR REV DATE