

- NOTES:
- 1- MATERIAL: BODY - POLYCARBONATE 10% FIBERGLASS REINFORCED  
COVER - POLYCARBONATE  
UL508 /NEMA TYPE 4X WITH IP-67 TUV RATING & UL-94V0 RATING
  - 2- FINISH: BODY - LIGHT GRAY  
COVER - LIGHT GRAY OR CLEAR (-C)
  - 3- SUPPLIED WITH FOUR NON-METALLIC CAPTIVE SCREWS FOR COVER MOUNTING
  - 4- CONTINUOUS GASKET IN COVER
  - 5- SUPPLIED WITH FOUR M4 x 8mm LG. TRUSS HEAD MACHINE SCREWS
  - 6- DIMENSIONS ARE INCH [MM]
  - 7- DRAWING FOR REFERENCE
  - 8- OPTIONAL ACCESSORIES:  
INTERNAL STEEL PANEL - #PIX-11766  
MOUNTING BRACKET KIT (STAINLESS STEEL) - #NBX-10922  
MOUNTING BRACKET KIT (PLASTIC) - #PIX-4117

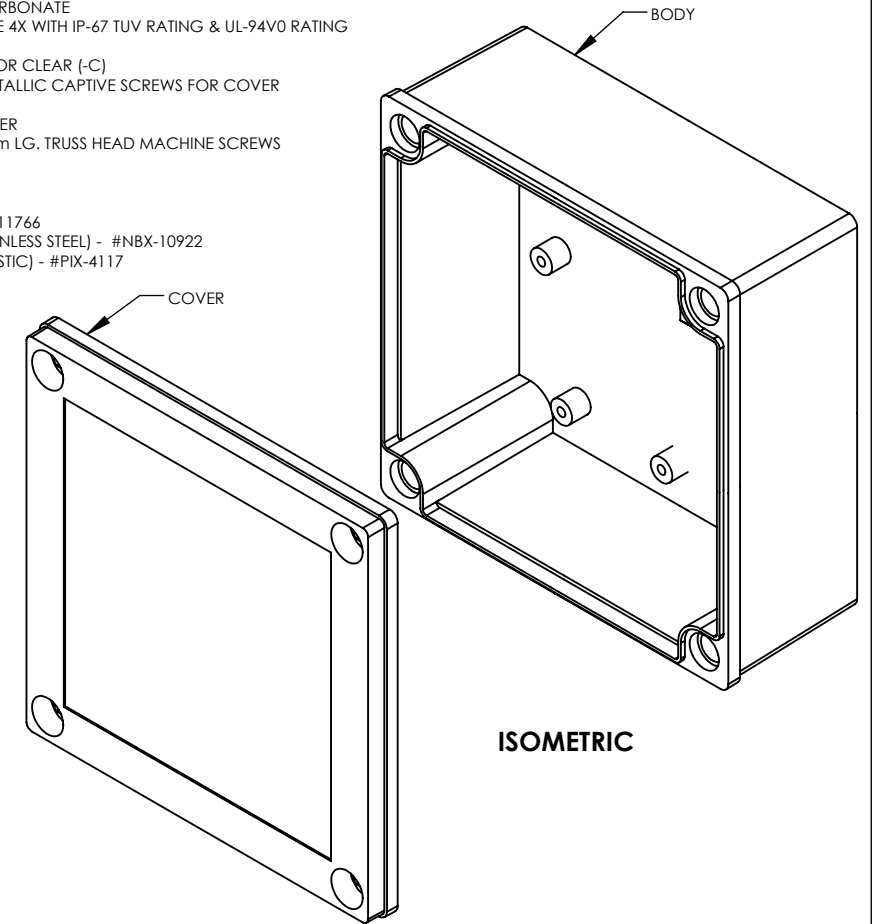

ASSEMBLY

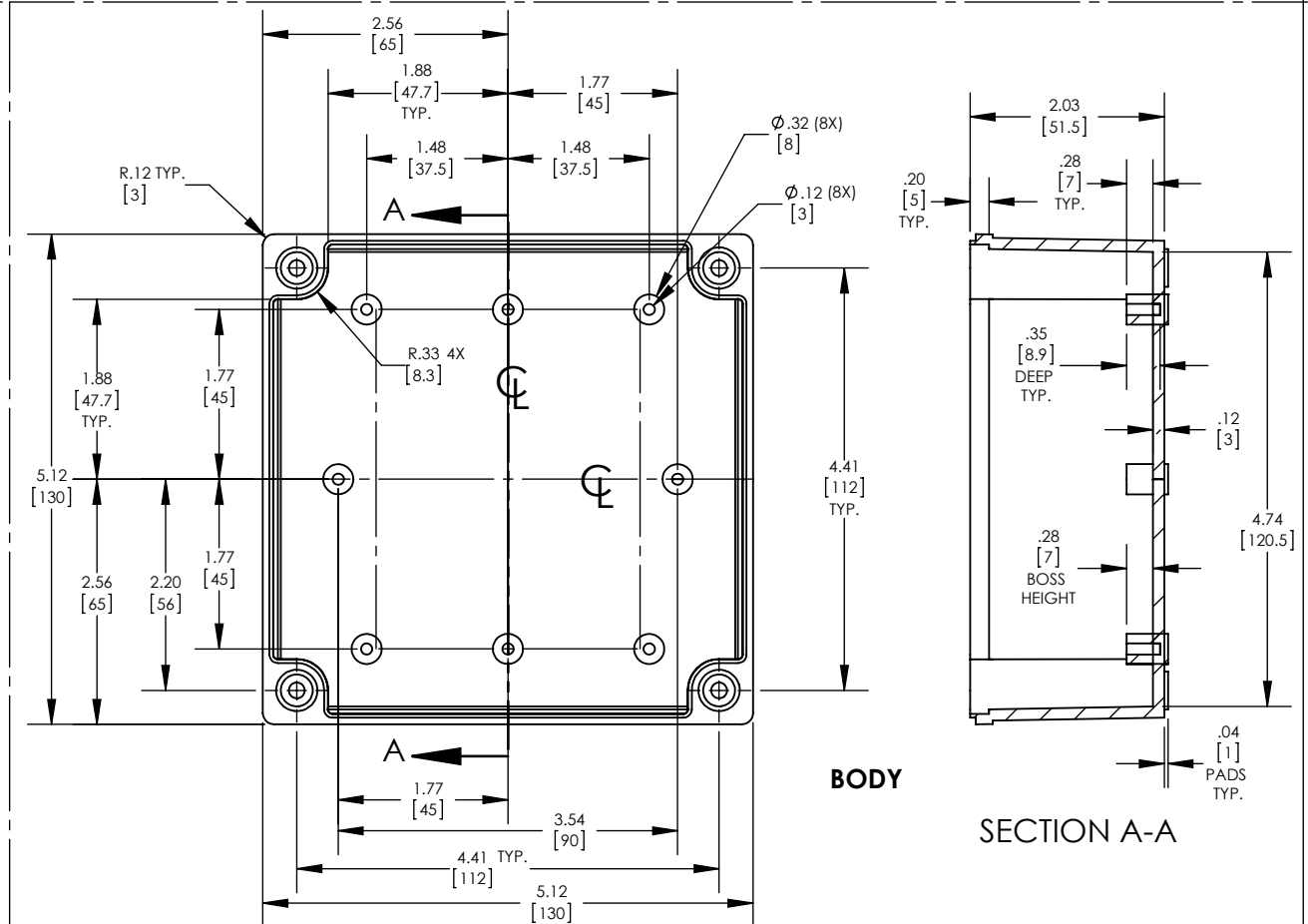
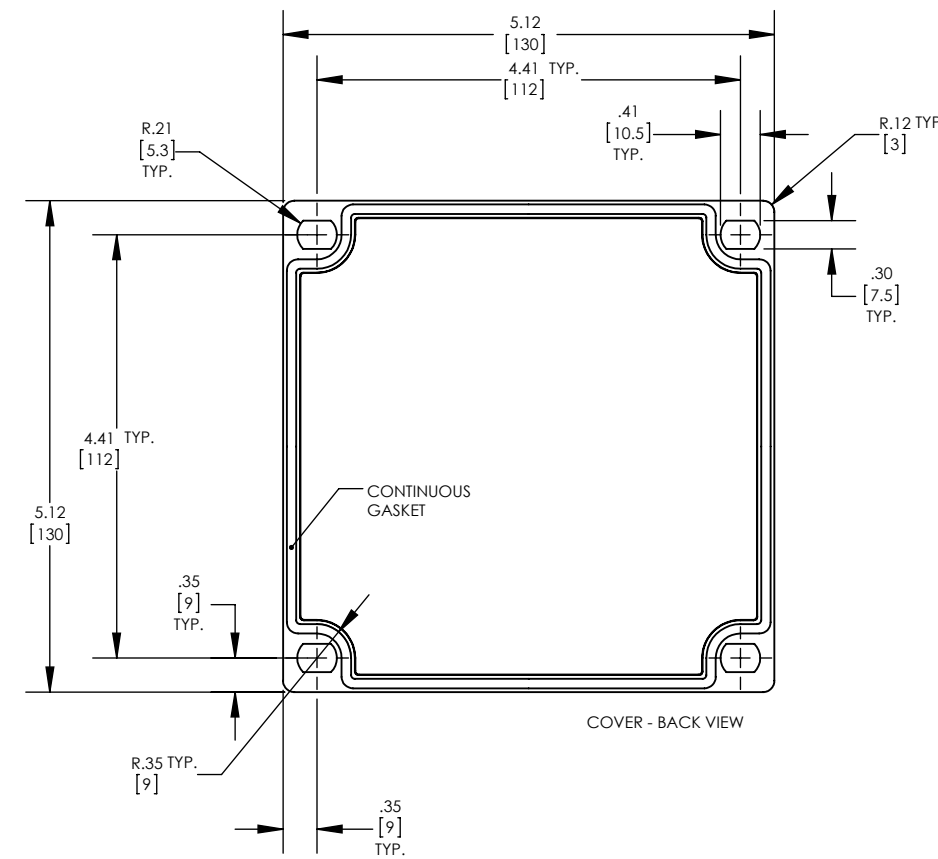
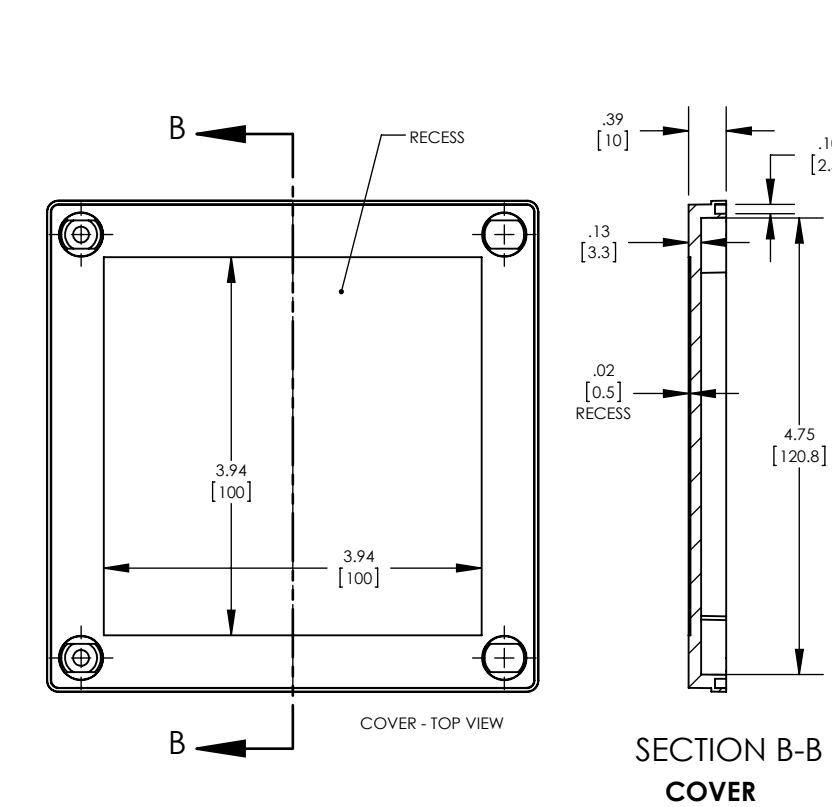

BODY

SECTION A-A