



High-Efficiency, 32V Step-Up Converters with TA Derating Option for 2 to 8 White LEDs

General Description

The MAX8595Z/MAX8596Z drive up to 8 white LEDs with constant current and high efficiency to provide LCD backlighting in cell phones, PDAs, and other handheld devices. The series connection allows the LED currents to be identical for uniform brightness and minimizes the number of traces to the LEDs. The MAX8595Z regulates constant LED current over the entire temperature range. The MAX8596Z features an ambient-temperature derating function to avoid overdriving the white LEDs during high ambient temperatures, enabling higher drive current below +42°C.

A single Dual Mode™ input provides a simple means of brightness adjustment and on/off control. Fast 1MHz current-mode PWM operation allows for small input and output capacitors and a small inductor while minimizing ripple on the input supply/battery. Soft-start eliminates inrush current during startup.

The MAX8595Z/MAX8596Z are available in a space-saving, 8-pin 3mm x 3mm TDFN package.

Applications

Cell Phones and Smart Phones
PDAs, Palmtops, and Wireless Handhelds
e-Books and Subnotebooks
White LED Display Backlighting

Dual Mode is a trademark of Maxim Integrated Products, Inc.

Typical Operating Circuit

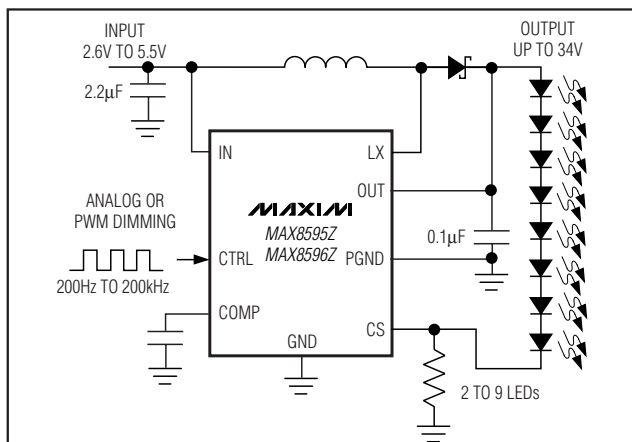

Features

- ◆ Up to 8 LEDs at 25mA
- ◆ Temperature Derating Function to Allow Fewer LEDs for Same Light (MAX8596Z)
- ◆ 86% Efficiency (PLEDs / P_{IN})
- ◆ 1.7% Current-Regulation Accuracy
- ◆ Output Overvoltage Protection
- ◆ Flexible Dimming Control
 - Analog
 - Direct-PWM Internal Filter
- ◆ 1MHz PWM Switching Frequency
- ◆ 0.1µF Output Capacitor
- ◆ 12mV_{p-p} Low Input Ripple
- ◆ Soft-Start Eliminates Inrush Current
- ◆ 2.6V to 5.5V Input Range
- ◆ 0.3µA Shutdown Current
- ◆ Pin Compatible with the MAX1561 and MAX1599
- ◆ TDFN 3mm x 3mm x 0.8mm Package with Exposed Paddle

Ordering Information

PART	TEMP RANGE	PIN-PACKAGE	PKG CODE
MAX8595ZETA-T	-40°C to +85°C	8 TDFN 3mm x 3mm	T833-1
MAX8595ZETA+T	-40°C to +85°C	8 TDFN 3mm x 3mm	T833-1
MAX8596ZETA-T	-40°C to +85°C	8 TDFN 3mm x 3mm	T833-1
MAX8596ZETA+T	-40°C to +85°C	8 TDFN 3mm x 3mm	T833-1

+Denotes lead-free package.

Pin Configuration

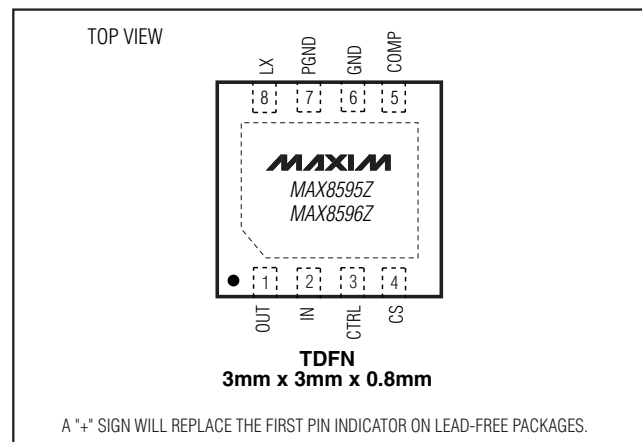

High-Efficiency, 32V Step-Up Converters with TA Derating Option for 2 to 8 White LEDs

ABSOLUTE MAXIMUM RATINGS

IN to GND	-0.3V to +6V
PGND to GND	-0.3V to +0.3V
LX, OUT to GND	-0.3V to +37V
CTRL to GND	-0.3V to the lower of +6V or (VIN + 2V)
COMP, CS to GND	-0.3V to (VIN + 0.3V)
ILX	1.0ARMS

Continuous Power Dissipation (TA = +70°C)	8-Pin TDFN 3mm x 3mm	1950mW
(derate 24.4mW/°C above +70°C)		
Operating Temperature Range		-40°C to +85°C
Junction Temperature		+150°C
Storage Temperature Range		-65°C to +150°C
Lead Temperature (soldering, 10s)		+300°C

Stresses beyond those listed under "Absolute Maximum Ratings" may cause permanent damage to the device. These are stress ratings only, and functional operation of the device at these or any other conditions beyond those indicated in the operational sections of the specifications is not implied. Exposure to absolute maximum rating conditions for extended periods may affect device reliability.

ELECTRICAL CHARACTERISTICS

(VIN = 3.0V, L = 22μH, CIN = 2.2μF, COUT = 0.1μF, CCOMP = 0.1μF, RSENSE = 13Ω, VCTRL = 1.5V, TA = -40°C to +85°C, unless otherwise noted. Typical values are at TA = +25°C.) (Note 1)

PARAMETER	CONDITIONS	MIN	TYP	MAX	UNITS	
Supply Voltage		2.6		5.5	V	
UVLO Threshold	VIN rising or falling	2.10	2.38	2.55	V	
UVLO Hysteresis			30		mV	
Quiescent Current	No switching		0.5	0.7	mA	
Shutdown Supply Current	CTRL = GND, VOUT = VIN	TA = +25°C	0.3	2	μA	
		TA = +85°C	1			
OVLO Threshold	VOUT rising	32	34	36	V	
OVLO Hysteresis			2		V	
OUT Input Bias Current	VOUT = 32V, VCTRL > 0.24V		9	20	35	μA
	OUT = IN, CTRL = GND	TA = +25°C	0.01	1		
		TA = +85°C	0.1			
Output Voltage Range	(Note 2)	VIN - VD		32	V	
ERROR AMPLIFIER						
CTRL to CS Regulation	VCTRL = 1.50V, VIN = 2.6V to 5.5V	TA = +25°C	0.295	0.300	0.305	V
		TA = 0°C to +85°C	0.292	0.300	0.308	
		TA = -40°C to +85°C	0.290	0.300	0.310	
CS Input Bias Current	VCS = VCTRL / 5	TA = +25°C	0.01	1	μA	
		TA = +85°C	0.03			
CS Maximum Brightness Clamp Voltage	MAX8595Z, VCTRL = 3.0V		310	330	347	mV
	MAX8596Z, VCTRL = 3.0V	TA = -40°C to +25°C	330	345	360	
		TA = +42°C		343		
		TA = +85°C		106.5		
CTRL Voltage for CS Maximum Brightness Clamp	MAX8595Z		1.65		V	
	MAX8596Z		1.72			
CS Derating Function Start Temperature	MAX8596Z, VCTRL = 3.0V		+42		°C	

High-Efficiency, 32V Step-Up Converters with TA Derating Option for 2 to 8 White LEDs

MAX8595Z/MAX8596Z

ELECTRICAL CHARACTERISTICS (continued)

($V_{IN} = 3.0V$, $L = 22\mu H$, $C_{IN} = 2.2\mu F$, $C_{OUT} = 0.1\mu F$, $C_{COMP} = 0.1\mu F$, $R_{SENSE} = 13\Omega$, $V_{CTRL} = 1.5V$, $T_A = -40^\circ C$ to $+85^\circ C$, unless otherwise noted. Typical values are at $T_A = +25^\circ C$.) (Note 1)

PARAMETER	CONDITIONS	MIN	TYP	MAX	UNITS
CS Derating Function Slope	MAX8596Z, $V_{CTRL} = 3.0V$, $T_A = +42^\circ C$ to $+85^\circ C$		-5.5		mV/ $^\circ C$
CTRL Input Resistance	$V_{CTRL} \leq 1.5V$	250	500	780	k Ω
CTRL Dual-Mode Threshold		100	170	240	mV
CTRL Dual-Mode Hysteresis			5		mV
CTRL Shutdown Enable Delay	(Note 3)	6.0	8.2	10.5	ms
CS to COMP Transconductance	$V_{COMP} = 1.5V$	32	50	82	μS
COMP Input Resistance to Ground	In shutdown, UVLO or OVLO		20		k Ω
OSCILLATOR					
Operating Frequency		0.75	1.0	1.25	MHz
Minimum Duty Cycle	PWM mode		12		%
	Pulse skipping		0		
Maximum Duty Cycle	CTRL = IN, CS = GND	94	95		%
N-CHANNEL SWITCH					
LX On-Resistance	$I_{LX} = 190mA$		0.8	1.35	Ω
LX Leakage Current	$V_{LX} = 36V$, CTRL = GND	$T_A = +25^\circ C$	0.01	5	μA
		$T_A = +85^\circ C$	1		
LX Current Limit	Duty cycle = 90%	500	700	900	mA

Note 1: Parameters are 100% production tested at $T_A = +25^\circ C$. Limits over the operating temperature range are regulated by design and characterization.

Note 2: V_D is the forward-voltage drop of the Schottky diode in Figure 1.

Note 3: Time from CTRL going below the Dual-Mode threshold to IC shutdown.

High-Efficiency, 32V Step-Up Converters with TA Derating Option for 2 to 8 White LEDs

Typical Operating Characteristics

(Circuit of Figure 1, $V_{IN} = 3.6V$, $I_{LED} = 25mA$, $L = 22\mu H$, $C_{IN} = 2.2\mu F$, $C_{OUT} = 0.1\mu F$, $C_{COMP} = 0.1\mu F$, $R_{SENSE} = 13\Omega$, 4 LEDs, $T_A = +25^\circ C$, unless otherwise noted.)

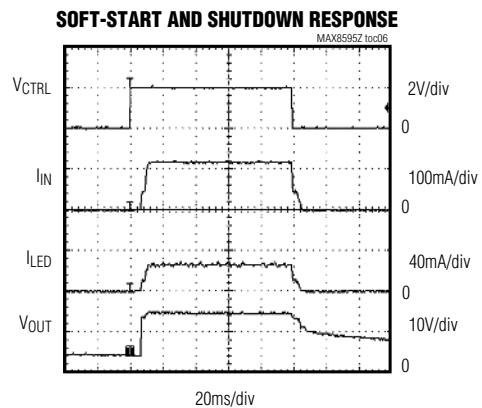
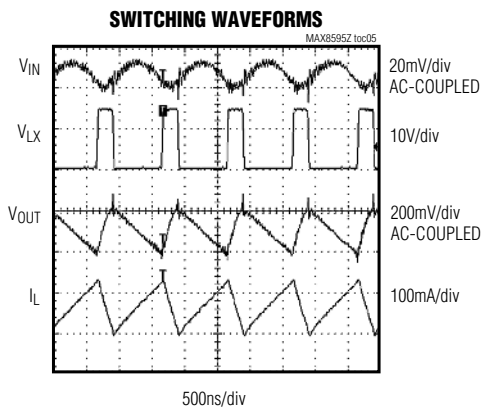
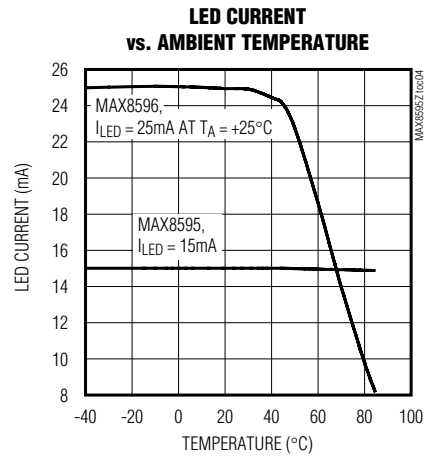
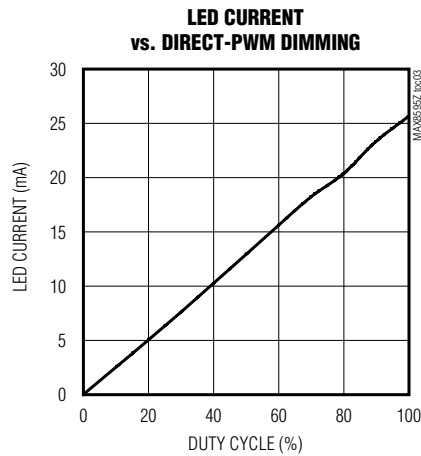
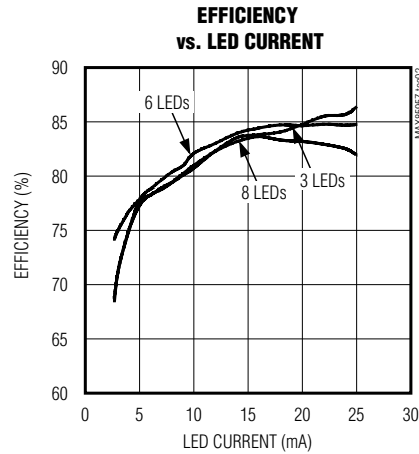
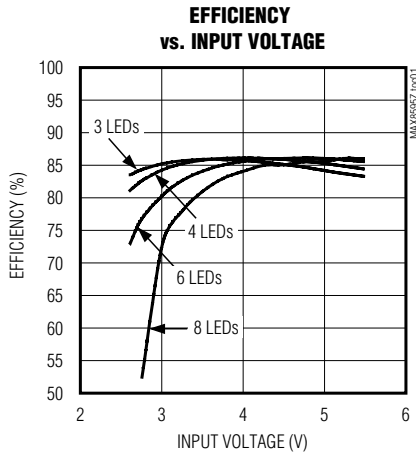

High-Efficiency, 32V Step-Up Converters with TA Derating Option for 2 to 8 White LEDs

Typical Operating Characteristics (continued)

(Circuit of Figure 1, $V_{IN} = 3.6V$, $I_{LED} = 25mA$, $L = 22\mu H$, $C_{IN} = 2.2\mu F$, $C_{OUT} = 0.1\mu F$, $C_{COMP} = 0.1\mu F$, $R_{SENSE} = 13\Omega$, 4 LEDs, $T_A = +25^\circ C$, unless otherwise noted.)

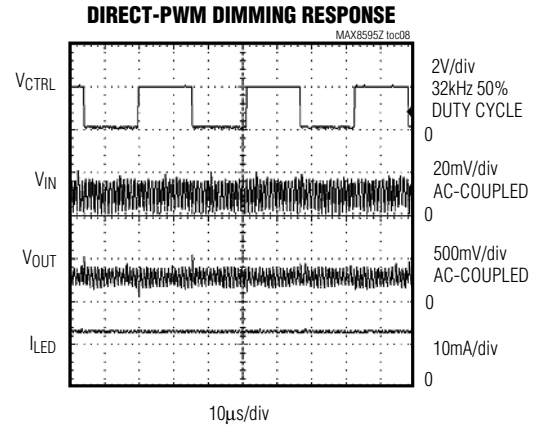
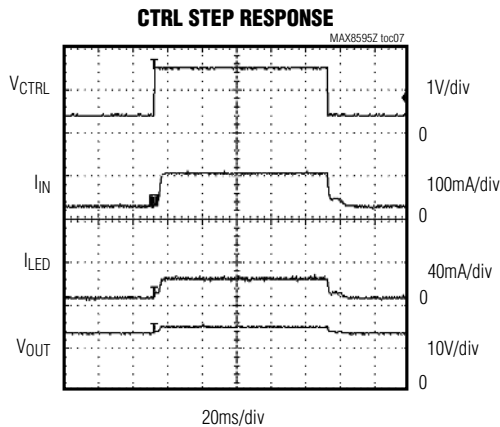

MAX8595Z/MAX8596Z

Pin Description

PIN	NAME	FUNCTION
1	OUT	Overvoltage Sense. When V_{OUT} is greater than 34V (typ), the internal n-channel MOSFET turns off until V_{OUT} drops below 32V (typ), then the IC re-enters soft-start. Connect a 0.1µF ceramic capacitor from OUT to ground. In shutdown, V_{OUT} is one diode drop below V_{IN} .
2	IN	Input Voltage Supply. The input voltage range is 2.6V to 5.5V. Connect a 2.2µF ceramic capacitor from IN to GND.
3	CTRL	Brightness Control Input. The voltage applied to CTRL controls LED brightness. Varying the voltage from 0.24V to 1.65V (1.72V for the MAX8596Z) adjusts the brightness from dim to 100% brightness, respectively. Any voltage above 1.65V (1.72V) does not increase brightness. Hold CTRL below 100mV to shut down the IC after an 8.2ms delay.
4	CS	Current-Sense Feedback Input. Connect a resistor from CS to GND to set the LED bias current. The voltage at CS regulates to $V_{CTRL} / 5$ or 0.330V (0.343V for the MAX8596Z), whichever is lower.
5	COMP	Compensation Input. Connect a 0.1µF ceramic capacitor (C_{COMP}) from COMP to GND. C_{COMP} stabilizes the converter, controls soft-start, and lowpass filters direct PWM dimming at CTRL. C_{COMP} discharges to 0V through an internal 20kΩ resistor in shutdown.
6	GND	Ground. Connect to PGND and the exposed pad directly under the IC.
7	PGND	Power Ground. Connect to GND and the exposed pad directly under the IC.
8	LX	Inductor Connection. Connect LX to the node between the inductor and the Schottky diode. LX is high impedance in shutdown.
—	EP	Exposed Pad. Connect to a large ground plane for maximum package heat dissipation. Connect directly to GND and PGND under the IC.

High-Efficiency, 32V Step-Up Converters with TA Derating Option for 2 to 8 White LEDs

Detailed Description

The high efficiency and small size of the MAX8595Z/MAX8596Z make them ideally suited to drive up to 9 series-connected LEDs. These devices operate as a boost DC-DC converter that regulates output current rather than voltage. The MAX8595Z/MAX8596Z provide even illumination by sourcing the same output current through each LED, eliminating the need for expensive factory calibration. The fast 1MHz internal oscillator allows for a small inductor and small input and output capacitors while minimizing input and output ripple.

The single analog control input (CTRL) allows easy adjustment of LED brightness and on/off control. This allows simple logic-level on/off control, analog voltage control, or PWM duty-cycle control of both brightness and shutdown. In shutdown, supply current is reduced to a low 0.3 μ A (typ). A soft-start gradually illuminates the LEDs, eliminating the inrush current during startup.

The MAX8596Z has the additional feature of derating LED current as ambient temperature rises. Above +42°C, the CS regulation voltage is reduced at a rate of 5.5mV/°C, thus reducing the LED current.

Soft-Start

The MAX8595Z/MAX8596Z attain soft-start by charging CCOMP gradually with a current source. When VCOMP rises above 1.25V, the internal MOSFET begins switching at a reduced duty cycle. When VCOMP rises above 2.25V, the duty cycle is at its maximum. See the *Typical Operating Characteristics* for an example of soft-start operation.

Shutdown

The MAX8595Z/MAX8596Z enter shutdown when VCTRL is less than 100mV for more than 8.2ms. In shutdown, supply current is reduced to 0.3 μ A (typ) by powering down the entire IC except for the CTRL voltage-detection circuitry. CCOMP is discharged during shutdown, allowing the device to re-initiate soft-start when it is enabled. Although the internal n-channel MOSFET does not switch in shutdown, there is still a DC current path between the input and the LEDs through the inductor and Schottky diode. The minimum forward voltage of the LED array must exceed the maximum input voltage to ensure that the LEDs remain off in shutdown. However, with 2 or more LEDs, the forward voltage is large enough to keep leakage current low, less than 1 μ A (typ). Typical shutdown timing characteristics are shown in the *Typical Operating Characteristics*.

Overshoot Protection

Overshoot lockout (OVLO) occurs when VOUT is above 34V (typ). The protection circuitry stops the inter-

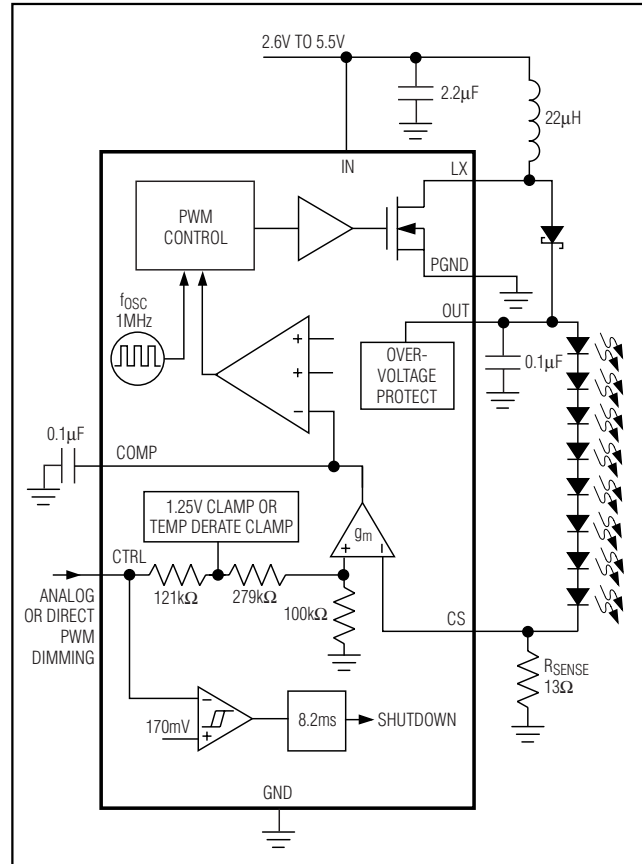

Figure 1. Functional Diagram and Typical Application Circuit

nal MOSFET from switching and causes VCOMP to decay towards 0V. The device comes out of OVLO and into soft-start when VOUT falls below 32V (typ).

Ambient Temperature Derating Function (MAX8596Z)

The MAX8596Z limits the maximum LED current depending on the die temperature. VCS is limited to 343mV up to +42°C. Once the temperature reaches +42°C, the maximum VCS declines by 5.5mV/°C until the minimum 106.5mV threshold is reached at +85°C. Due to the package's exposed paddle, the die temperature is always very close to the PC board temperature.

The temperature derating function allows the LED current to be safely set higher at normal operating temperatures, thereby allowing either a brighter display or fewer LEDs to be used for normal display brightness. See the *Typical Operating Characteristics* for LED Current vs. Ambient Temperature.

High-Efficiency, 32V Step-Up Converters with TA Derating Option for 2 to 8 White LEDs

MAX8595Z/MAX8596Z

Design Procedure

Adjusting LED Current

Adjusting the output current of the MAX8595Z/MAX8596Z changes the brightness of the LEDs. An analog input (CTRL) and the sense-resistor value set the output current. Output current is given by:

$$I_{LED} = V_{CTRL} / (5 \times R_{SENSE})$$

The V_{CTRL} voltage range for adjusting output current is 0.24V to 1.65V (or 1.72V for the MAX8596Z). To set the maximum current, calculate R_{SENSE} when V_{CTRL} is at its maximum as follows:

$$\text{For the MAX8595Z, } R_{SENSE} = 1.65 / (5 \times I_{LED(MAX)})$$

$$\text{For the MAX8596Z, } R_{SENSE} = 1.72 / (5 \times I_{LED(MAX)})$$

Power dissipation in R_{SENSE} is typically less than 10mW, allowing the use of a small surface-mount resistor.

PWM Dimming Control

CTRL is also used as a digital input allowing LED brightness control with a logic-level PWM signal applied directly to CTRL. The frequency range is from 200Hz to 200kHz, while 0% duty cycle corresponds to zero current and 100% duty cycle corresponds to full current. The error amplifier and compensation capacitor form a lowpass filter so PWM dimming results in DC current to the LEDs without the need for any additional RC filters; see the *Typical Operating Characteristics*.

Capacitor Selection

Ceramic capacitors with X5R, X7R, or better dielectric are recommended for stable operation over the entire operating temperature range. The exact values of input and output capacitors are not critical. The typical value for the input capacitor is 2.2 μ F, and the typical value for the output capacitor is 0.1 μ F. Higher-value capacitors can be used to reduce input and output ripple, but at the expense of size and higher cost. C_{COMP} stabilizes the converter and controls soft-start. Connect a 0.1 μ F capacitor from COMP to GND. For stable operation, C_{OUT} must not exceed 10 times C_{COMP} .

Inductor Selection

Inductor values range from 10 μ H to 47 μ H. A 22 μ H inductor optimizes the efficiency for most applications while maintaining low 12mV_{PP} input ripple. With input voltages near 5V, a larger value of inductance can be

more efficient. To prevent core saturation, ensure that the inductor-saturation current rating exceeds the peak inductor current for the application. Calculate the peak inductor current with the following formula:

$$I_{PEAK} = \frac{V_{OUT(MAX)} \times I_{LED(MAX)}}{0.9 \times V_{IN(MIN)}} + \frac{V_{IN(MIN)} \times 0.9\mu s}{2 \times L}$$

Schottky Diode Selection

The high switching frequency of the MAX8595Z/MAX8596Z demands a high-speed rectification diode (D1) for optimum efficiency. A Schottky diode is recommended due to its fast recovery time and low forward-voltage drop. Ensure that the diode's average and peak current rating exceed the average output current and peak inductor current. In addition, the diode's reverse breakdown voltage must exceed V_{OUT} . The RMS diode current can be approximated from:

$$I_{DIODE(RMS)} = \sqrt{I_{OUT} \times I_{PEAK}}$$

Applications Information

PC Board Layout

Due to fast switching waveforms and high-current paths, careful PC board layout is required. An evaluation kit (MAX8596ZEVKIT) is available to speed design.

When laying out a board, minimize trace lengths between the IC and R_{SENSE} , the inductor, the diode, the input capacitor, and the output capacitor. Keep traces short, direct, and wide. Keep noisy traces, such as the LX node trace, away from CS. The IN bypass capacitor (C_{IN}) should be placed as close to the IC as possible. PGND and GND should be connected directly to the exposed paddle underneath the IC. The ground connections of C_{IN} and C_{OUT} should be as close together as possible. The traces from IN to the inductor and from the Schottky diode to the LEDs can be longer.

Chip Information

TRANSISTOR COUNT: 2143

PROCESS: BiCMOS

High-Efficiency, 32V Step-Up Converters with TA Derating Option for 2 to 8 White LEDs

Package Information

(The package drawing(s) in this data sheet may not reflect the most current specifications. For the latest package outline information, go to www.maxim-ic.com/packages.)

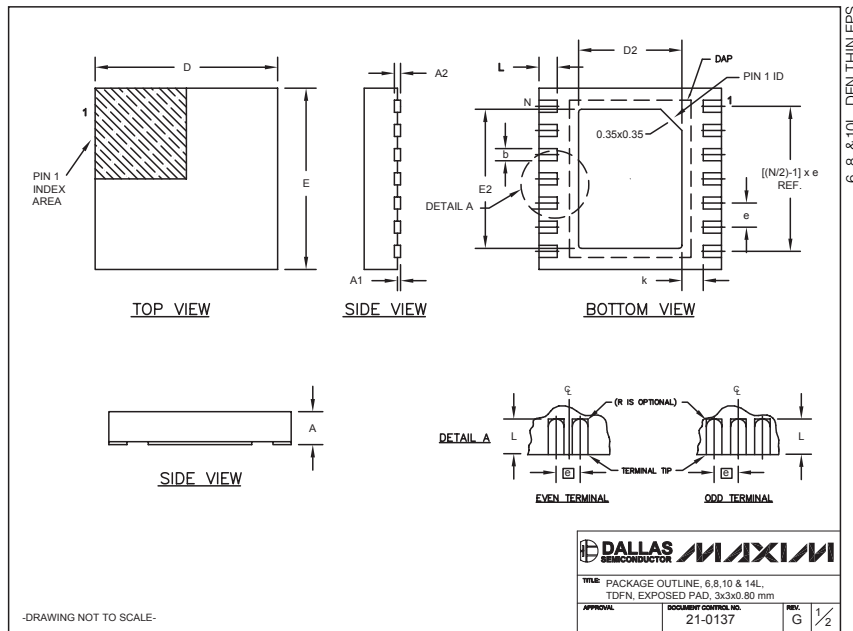

COMMON DIMENSIONS							
SYMBOL	MIN.	MAX.					
A	0.70	0.80					
D	2.90	3.10					
E	2.90	3.10					
A1	0.00	0.05					
L	0.20	0.40					
k	0.25 MIN.						
A2	0.20 REF.						

PACKAGE VARIATIONS								
PKG. CODE	N	D2	E2	e	JEDEC SPEC	b	[(N/2)-1] x e	DOWNBONDS ALLOWED
T633-1	6	1.50±0.10	2.30±0.10	0.95 BSC	MO229 / WEEA	0.40±0.05	1.90 REF	NO
T633-2	6	1.50±0.10	2.30±0.10	0.95 BSC	MO229 / WEEA	0.40±0.05	1.90 REF	NO
T833-1	8	1.50±0.10	2.30±0.10	0.65 BSC	MO229 / WEEC	0.30±0.05	1.95 REF	NO
T833-2	8	1.50±0.10	2.30±0.10	0.65 BSC	MO229 / WEEC	0.30±0.05	1.95 REF	NO
T833-3	8	1.50±0.10	2.30±0.10	0.65 BSC	MO229 / WEEC	0.30±0.05	1.95 REF	YES
T1033-1	10	1.50±0.10	2.30±0.10	0.50 BSC	MO229 / WEEED-3	0.25±0.05	2.00 REF	NO
T1433-1	14	1.70±0.10	2.30±0.10	0.40 BSC	----	0.20±0.05	2.40 REF	YES
T1433-2	14	1.70±0.10	2.30±0.10	0.40 BSC	----	0.20±0.05	2.40 REF	NO

NOTES:
 1. ALL DIMENSIONS ARE IN mm, ANGLES IN DEGREES.
 2. COPLANARITY SHALL NOT EXCEED 0.08 mm.
 3. WARPAGE SHALL NOT EXCEED 0.10 mm.
 4. PACKAGE LENGTH/PACKAGE WIDTH ARE CONSIDERED AS SPECIAL CHARACTERISTIC(S).
 5. DRAWING CONFORMS TO JEDEC MO229, EXCEPT DIMENSIONS "D2" AND "E2", AND T1433-1 & T1433-2.
 6. "N" IS THE TOTAL NUMBER OF LEADS.
 7. NUMBER OF LEADS SHOWN ARE FOR REFERENCE ONLY.

-DRAWING NOT TO SCALE-

DALLAS SEMICONDUCTOR		MAXIM	
TITLE: PACKAGE OUTLINE, 6, 8, 10 & 14L, TDFN, EXPOSED PAD, 3x3x0.80 mm			
APPROVAL:	DOCUMENT CONTROL NO.:	REV.:	QTY.:
	21-0137	G	2/2

Maxim cannot assume responsibility for use of any circuitry other than circuitry entirely embodied in a Maxim product. No circuit patent licenses are implied. Maxim reserves the right to change the circuitry and specifications without notice at any time.

8 Maxim Integrated Products, 120 San Gabriel Drive, Sunnyvale, CA 94086 408-737-7600