

**SPECIFICATION
FOR
LCD Module**

Customer P/N:

Santek P/N: ST0430E2WCY-RSLW-F

DOC. Revision: RS01

Customer Approval:

--

	SIGNATURE	DATE
PREPARED BY	Aaron Lu	2020-05-13
CHECKED BY	<i>Andy Song</i>	2020-05-29
APPROVED BY	<i>Natty Lee</i>	2020.Jun.3

Document Revision History

Version	Revise Date	Description	Changed by
RS01	2020-05-13	First issue	Aaron Lu

Santek - CONFIDENTIAL

Table of Contents

1. GENERAL SPECIFICATION.....4

2. BLOCK DIAGRAM5

3. MECHANICAL DRAWING.....6

4. INTERFACE ASSIGNMENT.....7

5. ELECTRICAL SPECIFICATION.....8

6. OPTICAL CHARACTERISTICS.....13

7. RELIABILITY TESTS.....18

8. PACKAGE DRAWING.....19

9. PRECAUTIONS.....20

10. LIMITED WARRANTY.....20

Santek - CONFIDENTIAL

1. GENERAL SPECIFICATION

1.1. Description

The ST0430E2WCY-RSLW-F is a color active matrix Thin Film Transistor (TFT) Liquid Crystal Display (LCD) that uses amorphous silicon (a-Si) TFT as a switching device. This model is composed of a single 4.3 inches transmissive type main TFT-LCD panel and touch panel. The resolution of the panel is 480(RGB) x 272 pixels and can display up to 16.7M color.

1.2. Feature

- TN type for main TFT-LCD panel
- Structure COG+FPC+BL+FRM+CTP

1.3. Application

- Display terminals for digital product

1.4. General Specification

No.	Item	Specification	Unit	Remark
1	LCD Size	4.3	inch	-
2	Panel Type	a-Si TFT active matrix	-	-
3	Resolution	480 x (RGB) x 272	pixel	-
4	Display Mode	Normally white, Transmissive	-	-
5	Display Number of Colors	16.7M	-	-
6	Viewing Direction	6 o'clock	-	Note
7	Contrast Ratio	500(Typ.)	-	-
8	Luminance	450(Typ.)	cd/m ²	-
9	Module Size	117.5(W) x 78.02(H) x 3.93(T)	mm	Note
10	Active Area	95.04 (W) x 53.86(H)	mm	Note
11	Pixel Pitch	0.198 x 0.198	mm	-
12	Weight	TBD	g	-
13	Driver IC	HX8257-A	-	-
14	Light Source	10 LEDs White	-	-
15	Interface	RGB 24bit	-	-
16	Operating Temperature	-20~70	°C	-
17	Storage Temperature	-30~80	°C	-

Note: Please refer to the mechanical drawing.

2.BLOCK DIAGRAM

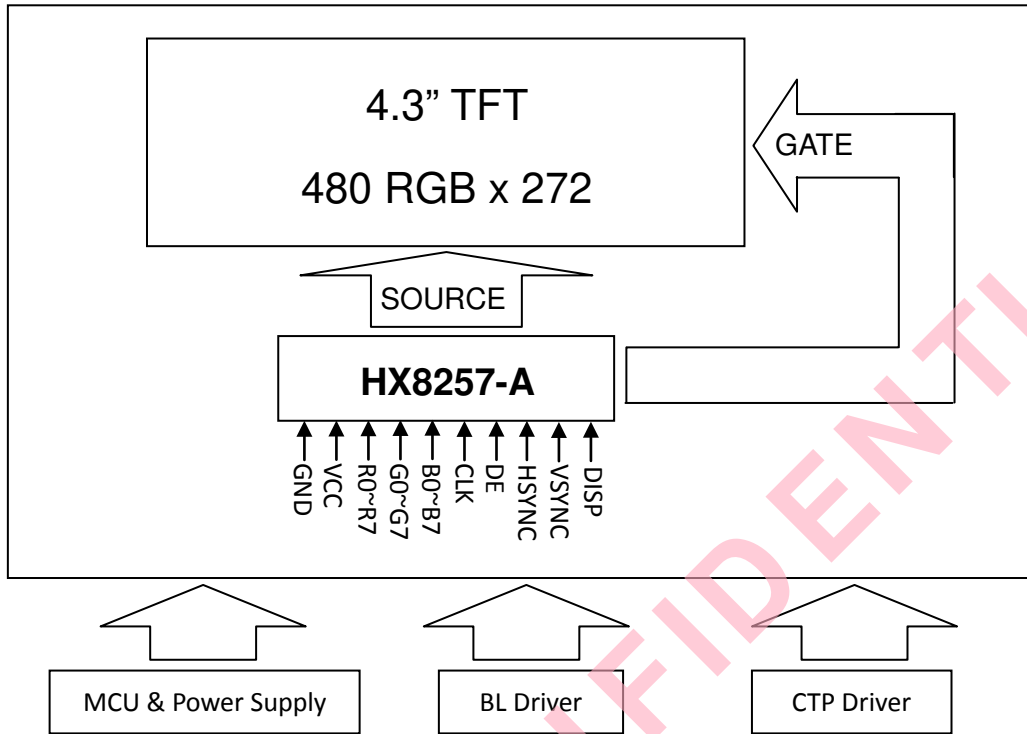

3. MECHANICAL DRAWING

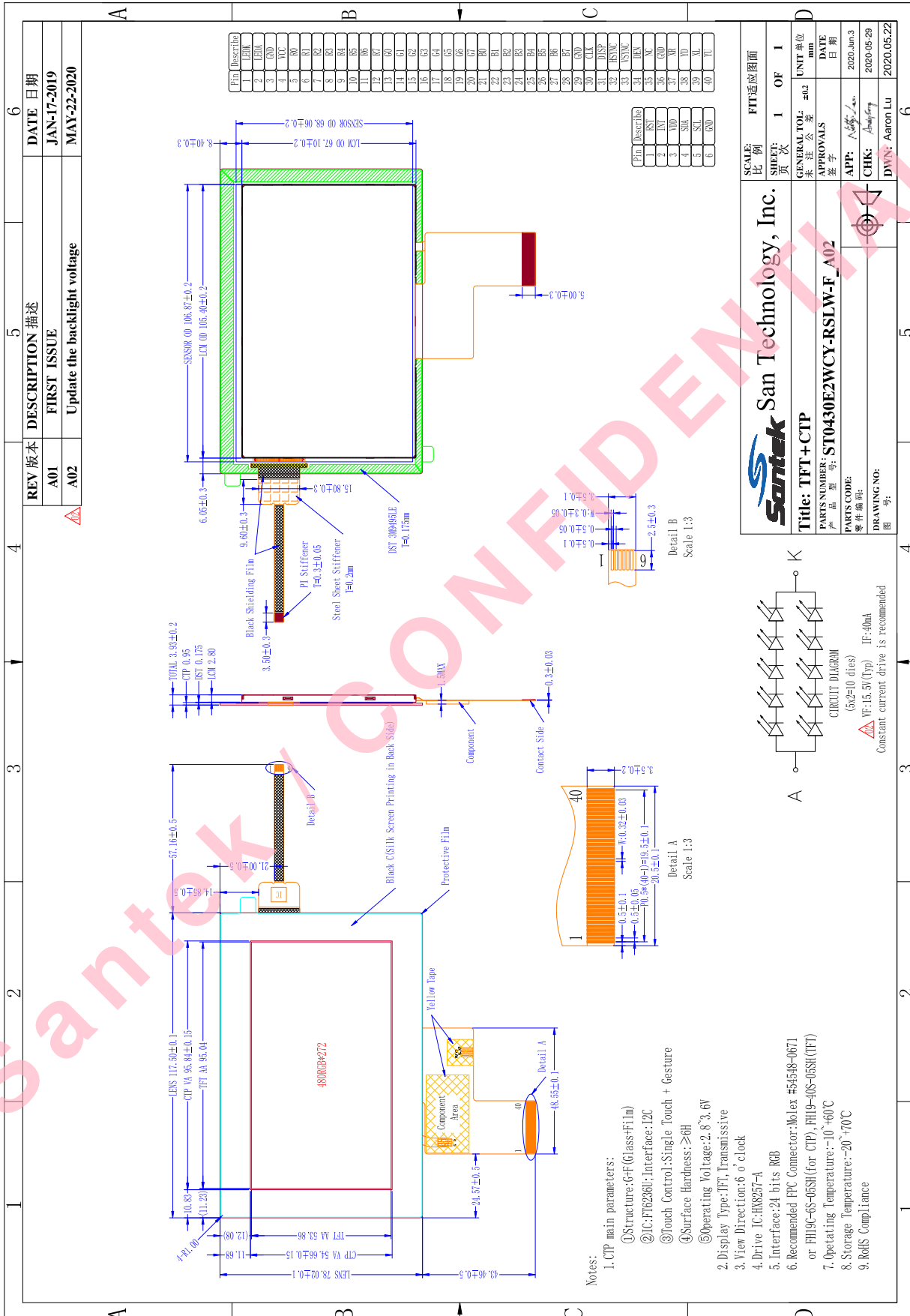

4. INTERFACE ASSIGNMENT

PIN NO.	SYMBOL	I/O	FUNCTION DESCRIPTIONS
1	LEDK	P	Backlight Cathode
2	LEDA	P	Backlight Anode
3	GND	P	Ground
4	VDD	P	Digital Power
5	R0	I	Red data signal(LSB)
6	R1	I	Red data signal
7	R2	I	Red data signal
8	R3	I	Red data signal
9	R4	I	Red data signal
10	R5	I	Red data signal
11	R6	I	Red data signal
12	R7	I	Red data signal(MSB)
13	G0	I	Green data signal(LSB)
14	G1	I	Green data signal
15	G2	I	Green data signal
16	G3	I	Green data signal
17	G4	I	Green data signal
18	G5	I	Green data signal
19	G6	I	Green data signal
20	G7	I	Green data signal(MSB)
21	B0	I	Blue data signal(LSB)
22	B1	I	Blue data signal
23	B2	I	Blue data signal
24	B3	I	Blue data signal
25	B4	I	Blue data signal
26	B5	I	Blue data signal
27	B6	I	Blue data signal
28	B7	I	Blue data signal(MSB)
29	GND	I	Ground
30	CLK	I	Clock signal to sample each data
31	DISP	I	Display on/off signal (this pin is pulled high in internally)
32	HSYNC	I	Horizontal synchronizing signal
33	VSYNC	I	Vertical synchronizing signal
34	DE	I	Input data enable control. Internally pulled low.
35	NC	I	NC
36	GND	I	Ground
37	NC	-	NC
38	NC	-	NC
39	NC	-	NC
40	NC	-	NC

5. ELECTRICAL SPECIFICATION

5.1. APPLICATION CIRCUIT

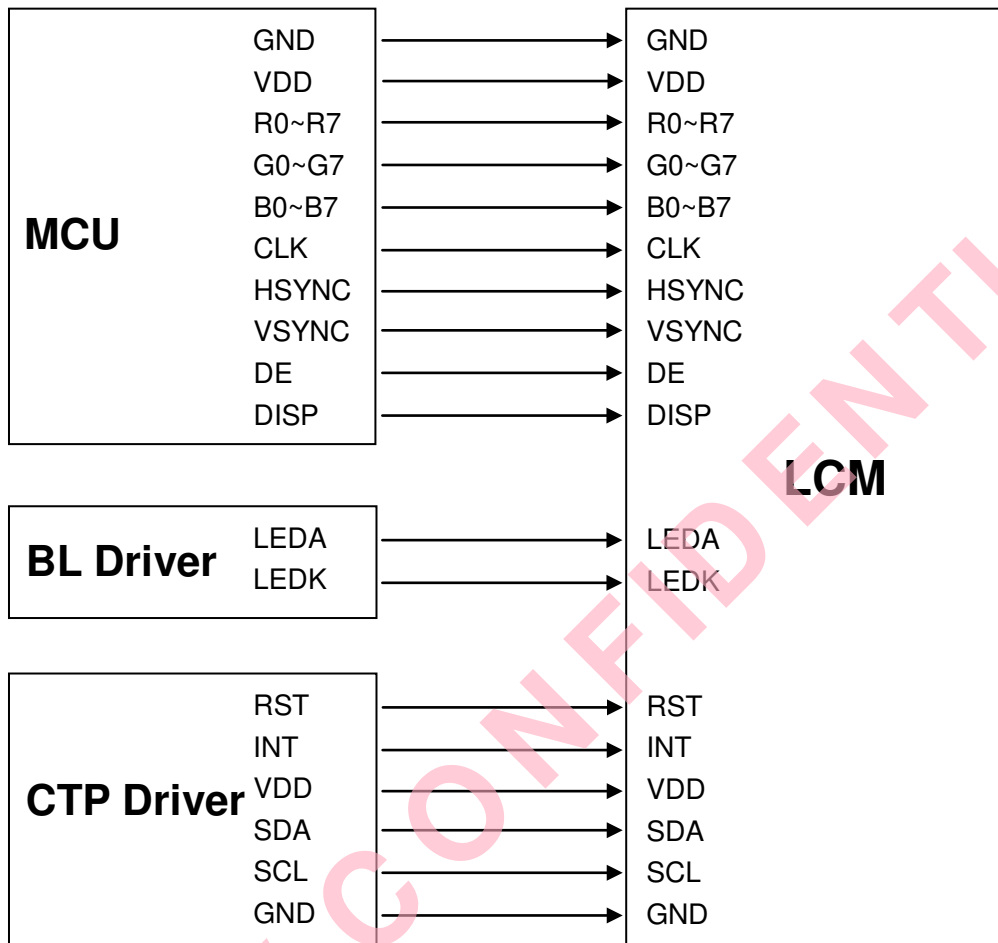

5.2. ABSOLUTE MAXIMUM RATINGS

ITEM	SYMBOL	CONDITION	STANDARD VALUE			UNIT
			MIN	TYP	MAX	
POWER SUPPLY FOR LOGIC	VDD	Ta=25°C	-0.3	-	+3.6	V
INPUT VOLTAGE	VCC	Ta=25°C	-0.3	-	+3.6	V
OPERATION TEMPERATURE	TOPR		-20		+70	°C
STORAGE TEMPERATURE	TSTG		-30		+80	°C

5.3. TYPICAL OPERATION CONDITION

5.3.1. DC Characteristics

Item	Symbol	Condition	Min.	Typ.	Max.	Unit
POWER SUPPLY VOLTAGE	VDD-GND	Ta= +25°C	-	3.3	-	V
INPUT VOLTAGE "H" LEVEL	VIH	-	0.8VDD	-	VDD	V
INPUT VOLTAGE "L" LEVEL	VIL	-	GND	-	0.2VDD	V
OUTPUT VOLTAGE "H" LEVEL	VOH	IOH=200uA	VDD-0.3	-	VDD	V
OUTPUT VOLTAGE "L" LEVEL	VOL	IOL=200uA	GND	-	GND+0.3	V

5.3.2. AC Characteristics

(480RGBx272, T_A=25°C, VDDIO=1.8V to 3.6V, DVSS= 0V)

Parameter	Symbol	Spec.			Unit
		Min.	Typ.	Max.	
Clock cycle	f _{CLK} ⁽¹⁾	-	9	15	MHz
Hsync cycle	1/th	-	17.14	-	KHz
Vsync cycle	1/tv	-	59.94	-	Hz
Horizontal signal					
Horizontal cycle	th	525	525	605	CLK
Horizontal display period	thd	480	480	480	CLK
Horizontal front porch	thf	2	2	82	CLK
Horizontal pulse width	thp ⁽²⁾	2	41	41	CLK
Horizontal back porch	thb ⁽²⁾	2	2	41	CLK
Vertical signal					
Vertical cycle	tv	285	286	399	H ⁽¹⁾
Vertical display period	tvd	272	272	272	H ⁽¹⁾
Vertical front porch	tvf	1	2	227	H ⁽¹⁾
Vertical pulse width	tvp ⁽²⁾	1	10	11	H ⁽¹⁾
Vertical back porch	tvb ⁽²⁾	1	2	11	H ⁽¹⁾

Note: (1) Unit: CLK=1/ f_{CLK}, H= th,

(2) It is necessary to keep tvp+tvb=12 and thp+thb=43 in sync mode. DE mode is unnecessary to keep it.

5.4. INTERFACE TIMING CHARACTERISTICS

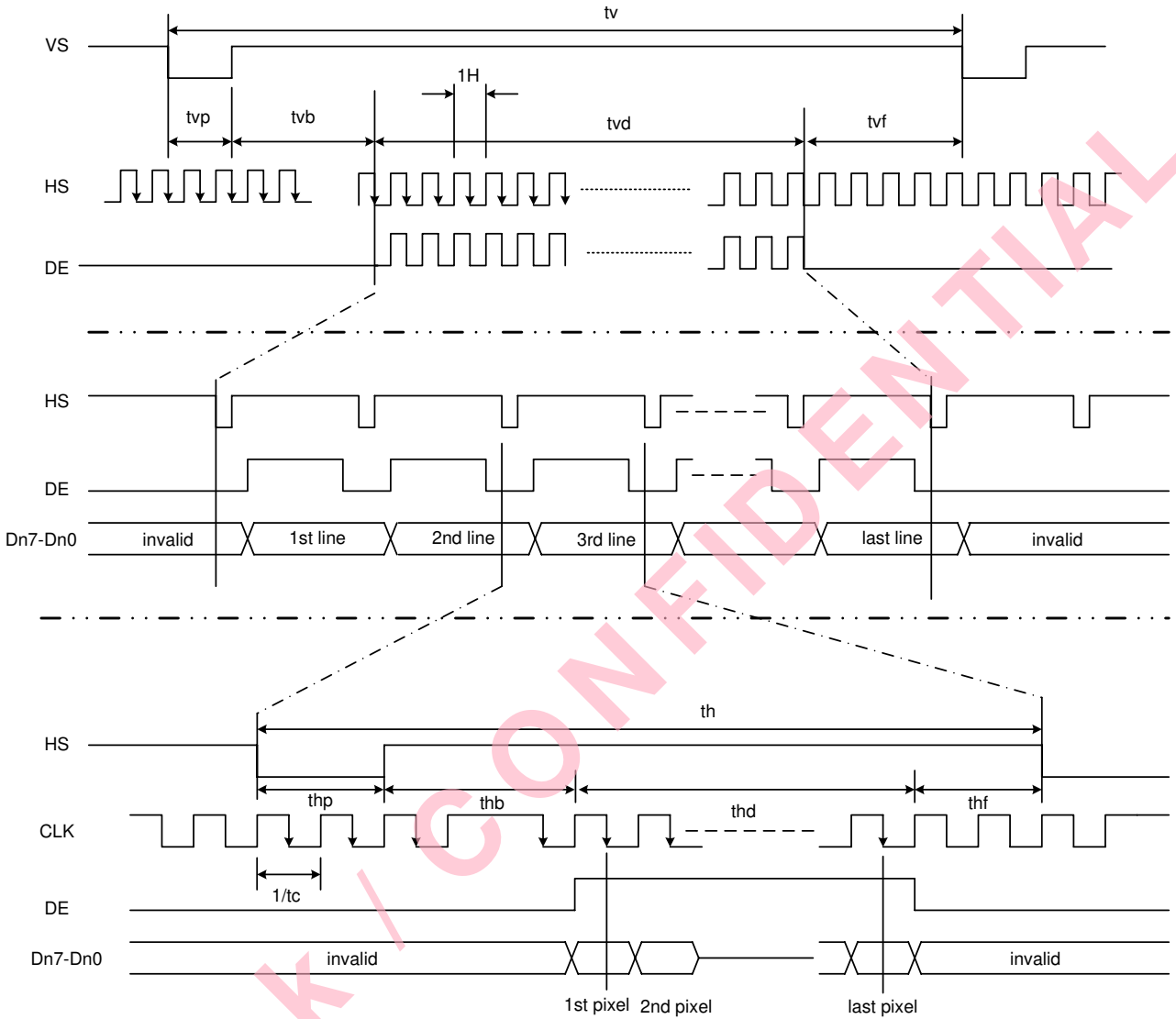

Parallel RGB Input Timing

5.6. POWER ON/OFF SEQUENCE

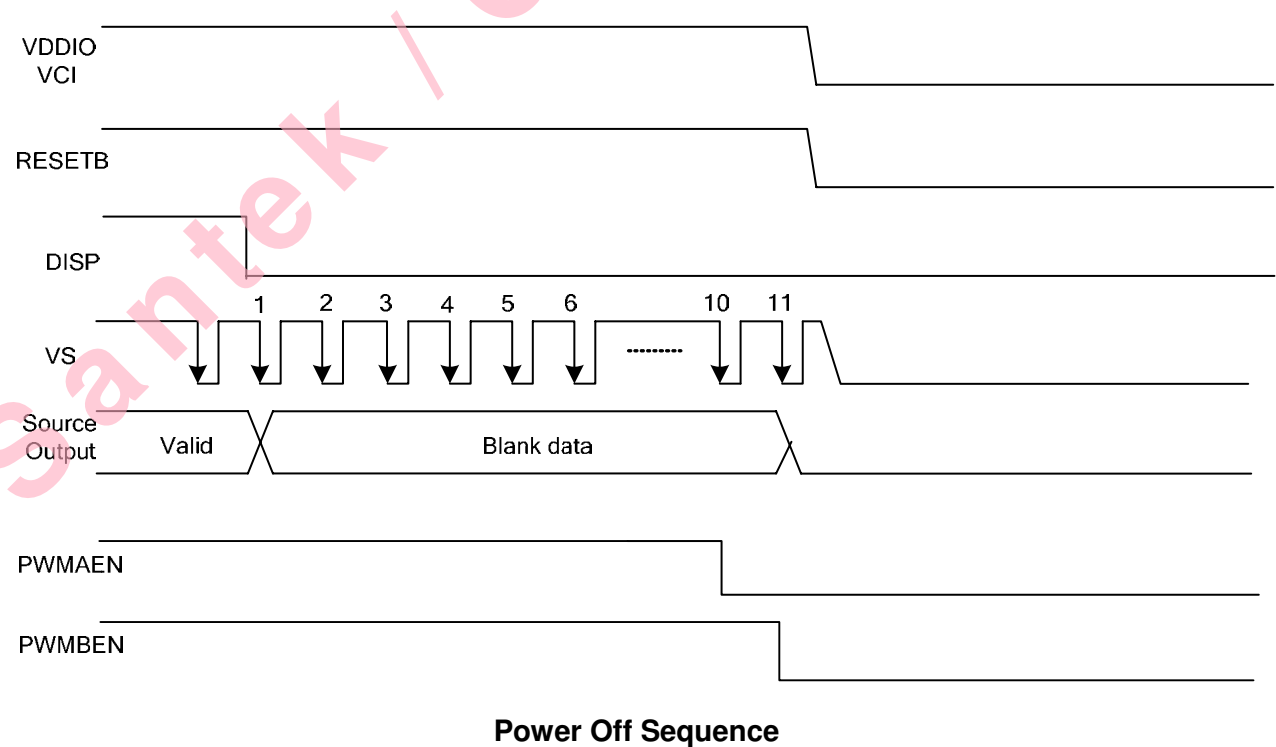
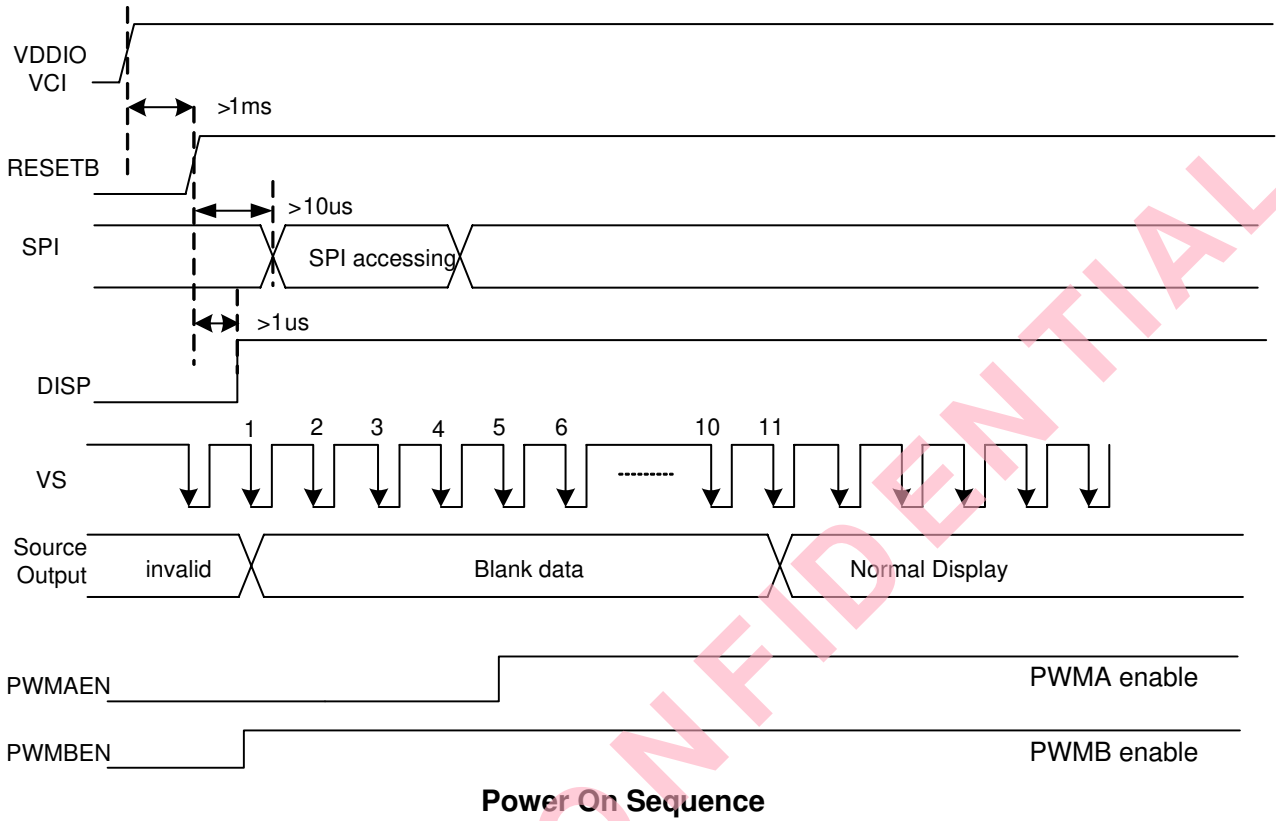

5.7. BACKLIGHT SPECIFICATION

5.7.1. Backlight Circuit

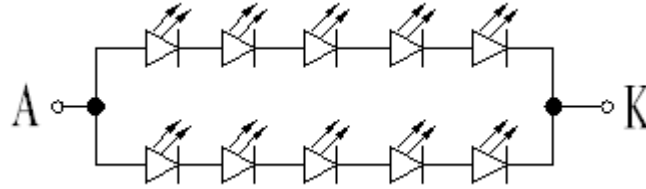

5.7.2. Absolute Ratings

PARAMETER	SYMBOL	SPECIFICATIONS	UNIT
POWER DISSIPATION	P_D	620	mW
FORWARD CURRENT (Single Chip)	I_{Fm}	20	mA
REVERSE VOLTAGE (Single Chip)	V_R	5	V

5.7.3. Electrical Characteristics

($T=25^{\circ}C$)

PARAMETER	SYMBOL	CONDITION	STANDARD VALUE			UNIT
			MIN	TYP	MAX	
FORWARD VOLTAGE	V_F	$I_F = 40mA$	13.5	15.5	17	V
OPERATING LED LIFE TIME (Single Chip)	Hr	$I_F = 20mA$	-	30,000	-	Hour

Note (1) LED life time (Hr) can be defined as the time in which it continues to operate under the condition: $T_a = 25 \pm 3^{\circ}C$, typical I_F value indicated in the above table until the brightness becomes less than 50%.

6. OPTICAL CHARACTERISTICS

($T_a=+25$, $VCC=+3.3V$, $I_{BL}=40mA$)

Item	Symbol	Condition	Values			Unit	Remark	
			Min.	Typ.	Max.			
Viewing Angle Range	Left	θ_L	CR ≥ 10	50	60	-	degree	Note 1,2
	Right	θ_R		50	60	-		
	Top	Φ_T		40	50	-		
	Botto	Φ_B		55	65	-		
Response Time	$T_{on} + T_{off}$	Normal $\theta = \Phi = 0^\circ$	-	30	50	ms	Note 2,3	
Contrast Ratio	CR	Normal $\theta = \Phi = 0^\circ$	300	500	-	-	Note 2,4	
Luminance	L	Normal $\theta = \Phi = 0^\circ$	360	450	-	cd/m ²	Note 2,5	
Color Chromaticity (CIE1931)	White	W_x	Normal $\theta = \Phi = 0^\circ$	0.2527	0.3027	0.3527	-	Note 2,6
		W_y		0.2719	0.3219	0.3719		
	Red	R_x		0.5398	0.5898	0.6398		
		R_y		0.3065	0.3565	0.4065		
	Green	G_x		0.3019	0.3519	0.4019		
		G_y		0.5365	0.5865	0.6365		
	Blue	B_x		0.0972	0.1472	0.1972		
		B_y		0.0381	0.0881	0.1381		
Color Gamut	NTSC	CIE1931	-	52	-	%	-	
Luminance Uniformity	U_L	Normal $\theta = \Phi = 0^\circ$	75	80	-	%	Note 2,7	
Flicker		Normal $\theta = \Phi = 0^\circ$	Not visible			-	Note 8	
Crosstalk		Normal $\theta = \Phi = 0^\circ$	Not visible			-	Note 9	

Note 1: Definition of viewing angle range

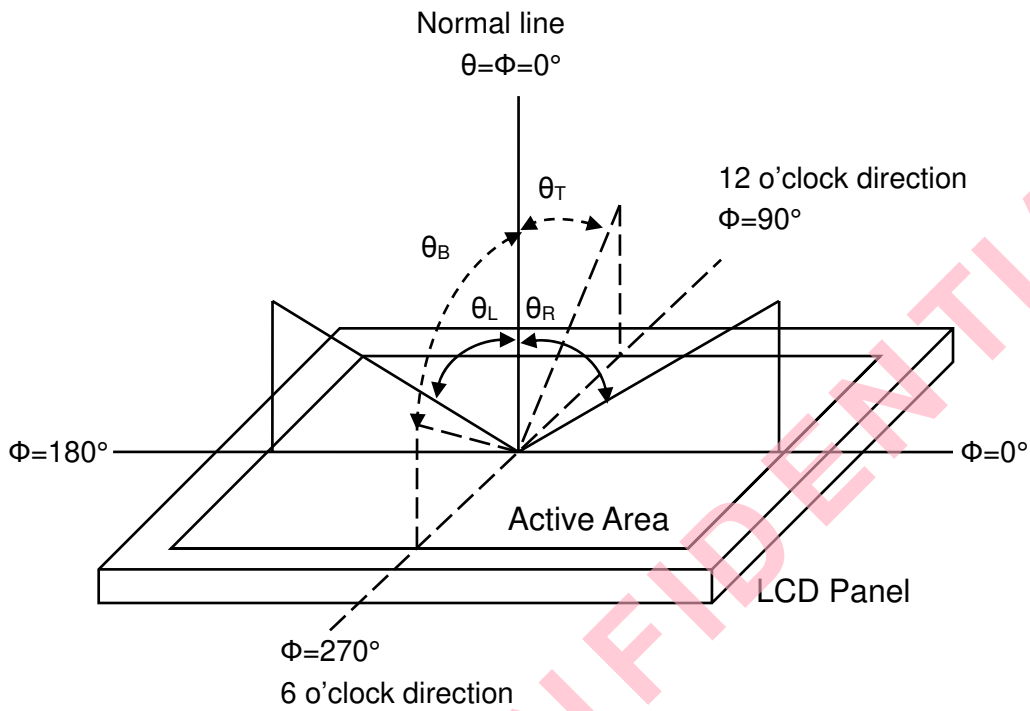

Fig. 1 Definition of viewing angle

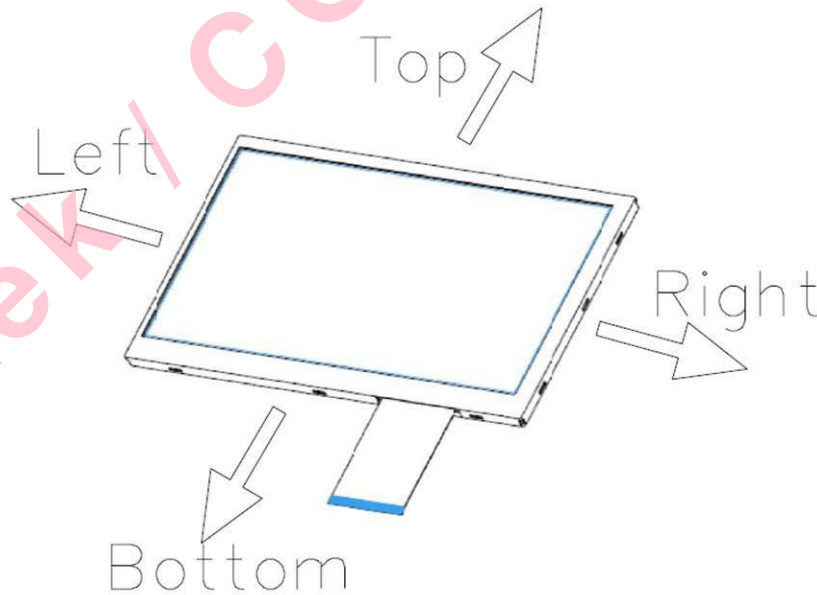

Fig. 2 Definition of viewing angle for display

Note 2: Definition of optical measurement system

The optical characteristics should be measured in a dark room with ambient temperature $T_a=+25^{\circ}\text{C}$. The optical properties are measured at the center point of the LCD screen after 5 minutes operation. (Equipment: Photo detector TOPCON BM-7 Field of view: 1° /Height: 500mm.)

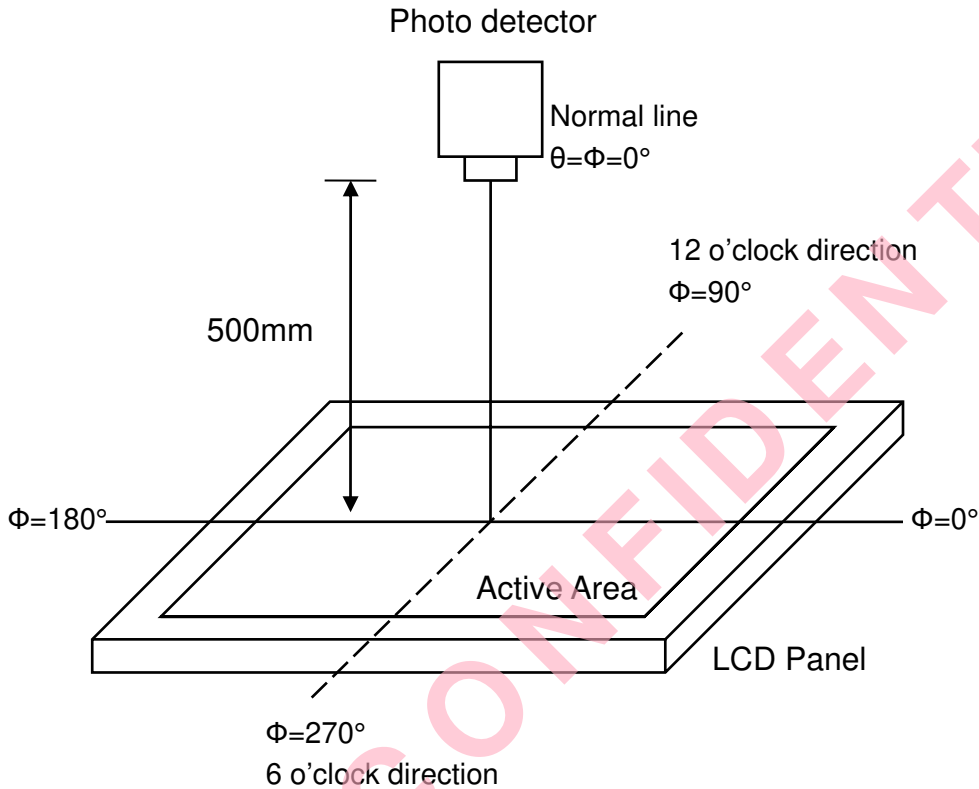

Fig. 3 Optical measurement system setup

Note 3: Definition of response time

The response time is defined as the LCD optical switching time interval between “White” state and “Black” state. Rise time (T_{on}) is the time between photo detector output intensity changed from 90% to 10%, and fall time (T_{off}) is the time between photo detector output intensity changed from 10% to 90%.

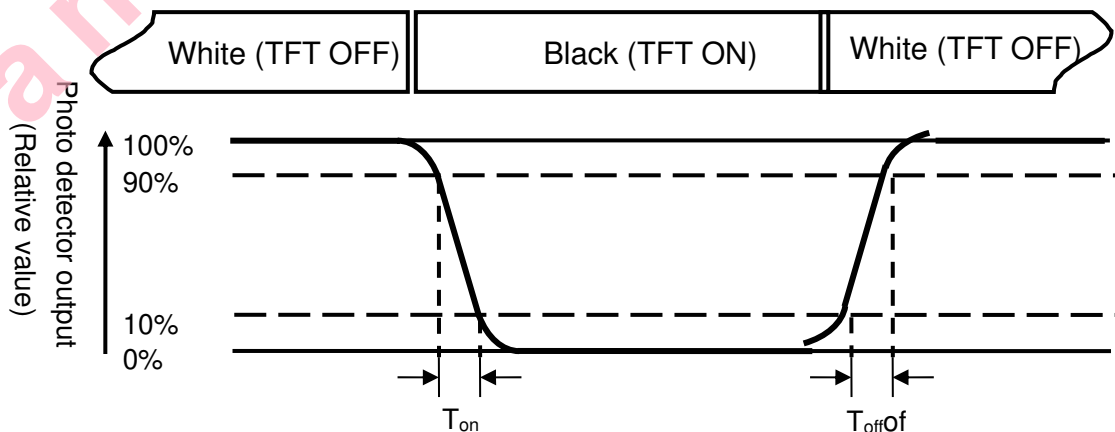

Fig. 4 Definition of response time

Note 4: Definition of contrast ratio

$$\text{Contrast ratio (CR)} = \frac{\text{Luminance measured when LCD on the "White" state}}{\text{Luminance measured when LCD on the "Black" state}}$$

Note 5: Definition of luminance

Measured at the center area of the panel when LCD panel is driven at “white” state.

Note 6: Definition of color chromaticity (CIE1931)

Color coordinates measured at the center point of LCD when panel is driven at “White”, “Red”, “Green” and “Blue” state respectively.

Note 7: Definition of luminance uniformity

To test for uniformity, the tested area is divided into 3 rows and 3 columns. The measurement spot is placed at the center of each circle as below.

$$\text{Luminance Uniformity (U}_L\text{)} = \frac{L_{\min}}{L_{\max}}$$

L-----Active area length W----- Active area width

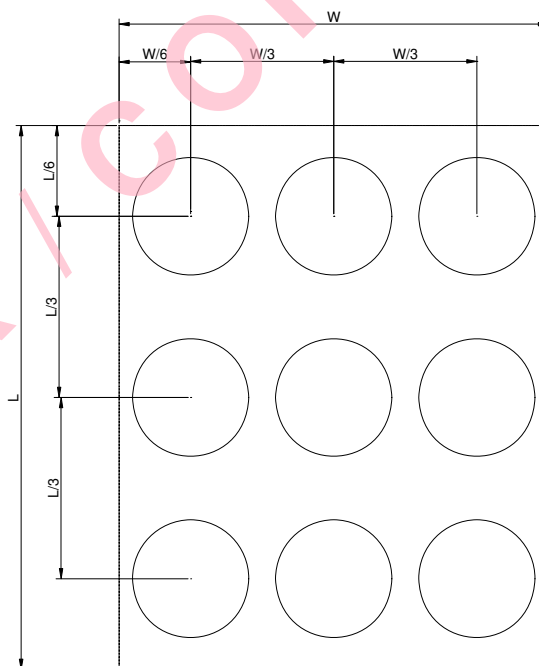

Fig. 5 Definition of luminance uniformity

L_{\min} : The measured minimum luminance of all measurement position.

L_{\max} : The measured maximum luminance of all measurement position.

Note 8: Definition of flicker

Flicker is the pattern usually used to describe the visual sensation produced by a rapidly varying light intensity. There should be no visible flicker in normal direction of the display when the following figure are loaded. The figure is composed of interlaced black and white lines.

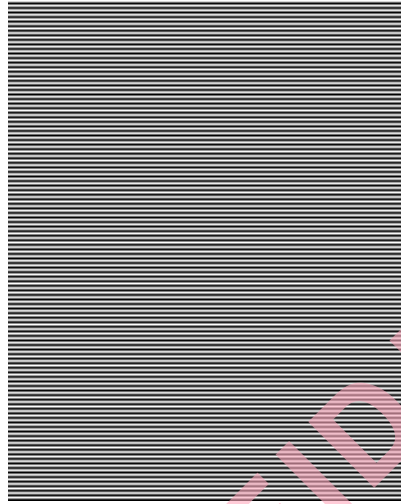

Fig.6 Flicker checker pattern

Note 9: Definition of crosstalk

There should be no visible in normal direction of the display when the following figures are loaded.

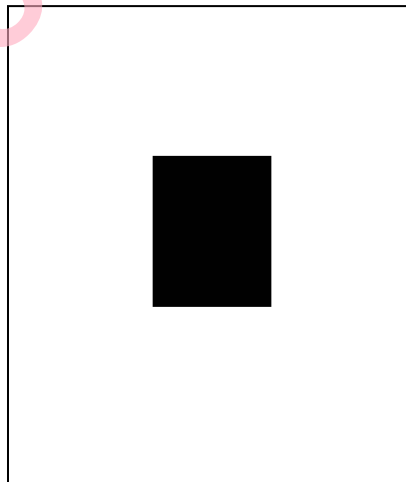

Fig.7 Crosstalk checker pattern

7. RELIABILITY TESTS

ITEM	CONDITION	CRITERION
Operating Temperature Test	High Temperature: +70 °C±2°C, 120hrs	No defects in display and operational functions
	Low Temperature: -20 °C±2°C, 120 hrs	
Storage Temperature Test	High Temperature: +80 °C±3°C, 120 hrs	No defects in display and operational functions
	Low Temperature: -30 °C±3°C, 120 hrs	
High Temp & High Humidity	60 °C, 90%RH, 120 hrs	No defects in display and operational functions
Thermal Shock Test	-30 °C (0.5 hrs) ↔ +80 °C (0.5 hrs) 20 cycles	No defects in display and operational functions
Vibration Test	Package Operating Time: 60 minutes exposure for each Y direction Sweep Frequency: 10~55Hz (1 min) Amplitude: 1.5mm Speed: 20m/s ²	No defects in display and operational functions
Package Drop Test	Height : 1.0m (Weight ≤ 10kg); 60cm (Weight ≥ 10kg) 1 corner, 3 edges, 6 surfaces	No defects in display and operational functions
Electro Static Discharge	± 2KV, Human Body Mode, 100pF/1500Ω ± 8KV, Air Mode, 100pF/1500Ω	No defects in display and operational functions

NOTE:

- 1) The samples must be free from defect before test, must be restored at room condition at least for 2 hours after reliability test before any inspection.
- 2) After a long period of high temperature, the surrounding edge of the LCM all-black image will appear Mura phenomenon, which is a normal phenomenon.

8. PACKAGE DRAWING

TBD

Santek / CONFIDENTIAL

9. PRECAUTIONS

9.1. HANDLING

9.1.1. Polarizer cleaning, Petroleum ether (or N-hexane) is recommended for cleaning the front/rear polarizers and reflectors, acetone, toluene and ethanol are not allowed to avoid damaging the surface.

9.1.2. Body grounding, must wear Anti-ESD wrist strap while pick up LCDs.

9.1.3. FPC soldering, less than 300 °C/3S, solder must be grounding on grounding bench.

9.1.4. If use electric Screwdriver to do assembly, screwdriver must be grounding.

9.2. STORAGE

9.2.1. Keep in a sealed polyethylene bag.

9.2.2. Keep in a dark place.

9.2.3. Keep in temperature between 0°C and 35°C.

NOT allowed at 70°C for more than 160 Hours, or at -20°C for more than 48 Hrs.

9.3. SAFETY

If liquid crystal leak out of a damaged glass cell, do not put it in your mouth or touch eyes, if the liquid crystal touch your skin or clothes, please wash it off immediately using soap and water.

10. LIMITED WARRANTY

Unless otherwise agreed between SANTEK and customer, SANTEK will replace or repair any of its LCD modules which are found to be functionally defective when inspected in accordance with SANTEK LCD acceptance standards (copies available upon request) for a period of one year from date of shipments. Cosmetic/visual defects over specs must be returned to SANTEK within 30 days of shipment. Confirmation of such date shall be based on freight documents. The warranty liability of SANTEK limited to repair and/or replacement on the terms set forth above. SANTEK shall not be responsible for any subsequent or consequential events.

10.1. RETURNING LCM UNDER WARRANTY – TERMS AND CONDITIONS

10.1.1. No warranty can be granted if the precautions stated above have been disregarded. The typical examples of violations are :

- Broken LCD glass.
- Circuit modified in any way, including addition of components.

10.1.2. Module repairs will be invoiced to the customer upon mutual agreement. Modules must be returned with sufficient description of the failures or defects. Any connectors or cable installed by the customer must be removed completely without damaging the PCB's eyelet, conductors and terminals.