

RICHCO PART NO.	WIRE O.D. RANGE	WIRE GA.	"D1"	"D2"	"L1" ±.04 (±1.0)	"L2"	"L" ±.04 (±1.0)	"T"
235815	.042-.060 (1.1-1.5)	26-22	.06 (1.5)	.12 (3.0)	.20 (5.0)	.12 (3.0)	.91 (23.0)	.03 (0.8)
235818	.042-.065 (1.1-1.7)	24-20	.07 (1.8)	.13 (3.3)	.20 (5.0)	.10 (2.5)	.91 (23.0)	.04 (1.0)
235820	.058-.080 (1.5-2.0)	24-20	.08 (2.0)	.14 (3.5)	.20 (5.0)	.10 (2.5)	.91 (23.0)	.03 (0.8)
235822	.058-.080 (1.5-2.0)	24-20	.09 (2.2)	.15 (3.7)	.20 (5.0)	.10 (2.5)	.91 (23.0)	.04 (1.0)
235825	.058-.091 (1.5-2.3)	22-18	.10 (2.5)	.14 (3.5)	.20 (5.0)	.10 (2.5)	.91 (23.0)	.03 (0.8)
235830	.058-.091 (1.5-2.3)	20-18	.12 (3.0)	.16 (4.0)	.20 (5.0)	.10 (2.5)	.91 (23.0)	.03 (0.8)
235835	.071-.140 (1.8-3.6)	18-14	.14 (3.5)	.18 (4.5)	.20 (5.0)	.12 (3.0)	.91 (23.0)	.03 (0.8)
235840	.113-.170 (2.9-4.3)	14-12	.16 (4.0)	.20 (5.0)	.20 (5.0)	.12 (3.0)	.91 (23.0)	.03 (0.8)
235845	.100-.140 (2.5-3.6)	16-14	.18 (4.5)	.22 (5.5)	.20 (5.0)	.12 (3.0)	.91 (23.0)	.03 (0.8)

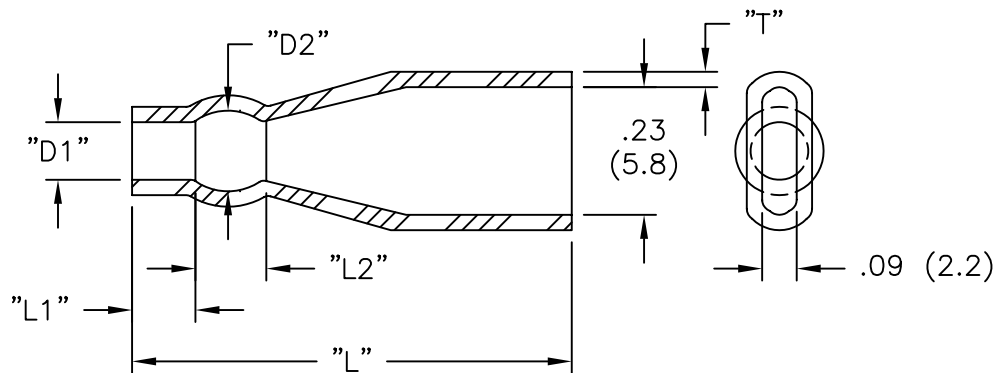

NOTES:

- MAT'L: SOFT PVC (RMS-55),  
UL YELLOW CARD E81260.
- COLOR: TRANSPARENT BLUE.

A	CHANGED FILE NO. AND TITLE BLOCK	SM 03.22.02
REV	DESCRIPTION	ENGR DATE

TITLE: "QUICK FIT" INSULATOR-187 SERIES				DWG IN IN (MM)		FINAL			
TOLERANCES UNLESS NOTED .XX=±.010 .XXX=±.005 FRAC=±1/64 ANG=±1'		FILE # 2358XX	DWN: P.B.	APP:	PART #		PRINT TYPE		
		MAT'L: SEE NOTES	DT: 12-22-95	DT:	SEE TABLE		CA		
		RE: RICHCO, INC.	RICHCO INC. PO BOX 804238, CHICAGO, 60680 (773) 539-4060						