

Features

- PWM and Direction-controlled Driving of Four Externally-powered NMOS Transistors
- High Temperature Capability up to 200°C Junction
- A Programmable Dead Time Is Included to Avoid Peak Currents Within the H-bridge
- Integrated Charge Pump to Provide Gate Voltages for High-side Drivers and to Supply the Gate of the External Battery Reverse Protection NMOS
- 5V/3.3V Regulator and Current Limitation Function
- Reset Derived From 5V/3.3V Regulator Output Voltage
- A Programmable Window Watchdog
- Battery Overvoltage Protection and Battery Undervoltage Management
- Overtemperature Warning and Protection (Shutdown)
- High Voltage Serial Interface for Communication
- QFN32/TPQFP Package

1. Description

The ATA6824 is designed for DC motor control application in automotive high temperature environment like in mechatronic assemblies in the vicinity of the hot engine, e.g. turbo charger. With a maximum junction temperature of 200°C, ATA6824 is suitable for applications with an ambient temperature up to 150°C.

The IC includes 4 driver stages to control 4 external power MOSFETs. An external microcontroller provides the direction signal and the PWM frequency. In PWM operation, the high-side switches are permanently on while the low-side switches are activated by the PWM frequency. ATA6824 contains a voltage regulator to supply the microcontroller; via the input pin VMODE the output voltage can be set to 5V or 3.3V respectively.

The on-chip window watchdog timer provides a pin-programmable time window. The watchdog is internally trimmed to an accuracy of 10%. For communication a high voltage serial interface with a maximum data range of 20 kBaud is integrated.

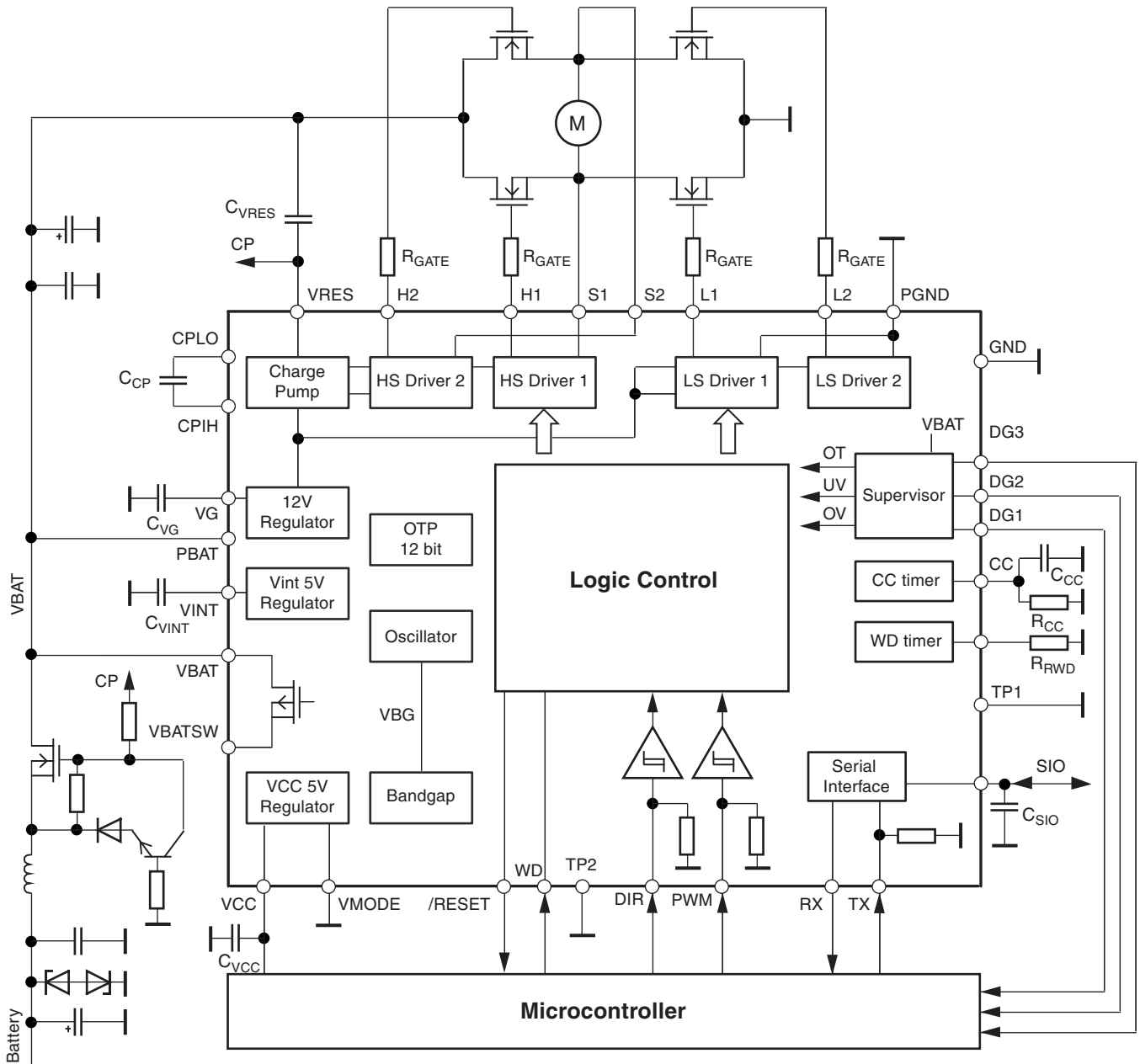


High Temperature H-bridge Motor Driver

ATA6824

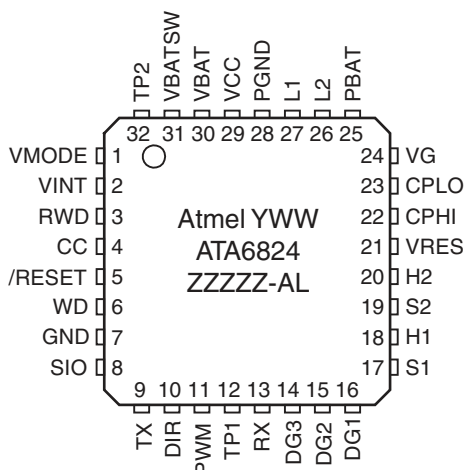


Figure 1-1. Block Diagram



2. Pin Configuration

Figure 2-1. Pinning QFN32/TPQFP32



Note: YWW Date code (Y = Year - above 2000, WW = week number)
 ATA6824 Product name
 ZZZZZ Wafer lot number
 AL Assembly sub-lot number

Table 2-1. Pin Description

Pin	Symbol	I/O	Function
1	VMODE	I	Selector for V_{CC} and interface logic voltage level
2	VINT	I/O	Blocking capacitor 220 nF/10V/X7R
3	RWD	I	Resistor defining the watchdog interval
4	CC	I/O	RC combination to adjust cross conduction time
5	/RESET	O	Reset signal for microcontroller
6	WD	I	Watchdog trigger signal
7	GND	I	Ground for chip core
8	SIO	I/O	High Voltage (HV) serial interface
9	TX	I	Transmit signal to serial interface from microcontroller
10	DIR	I	Defines the rotation direction for the motor
11	PWM	I	PWM input controls motor speed
12	TP1	–	Test pin to be connected to GND
13	RX	O	Receive signal from serial interface for microcontroller
14	DG3	O	Diagnostic output 3
15	DG2	O	Diagnostic output 2
16	DG1	O	Diagnostic output 1
17	S1	I/O	Source voltage H-bridge, high-side 1
18	H1	O	Gate voltage H-bridge, high-side 1
19	S2	I/O	Source voltage H-bridge, high-side 2
20	H2	O	Gate voltage H-bridge, high-side 2
21	VRES	I/O	Gate voltage for reverse protection NMOS, blocking capacitor 470 nF/25V/X7R

Table 2-1. Pin Description (Continued)

Pin	Symbol	I/O	Function
22	CPHI	I	Charge pump capacitor 220 nF/25V/X7R
23	CPLO	O	
24	VG	I/O	Blocking capacitor 470 nF/25V/X7R
25	PBAT	I	Power supply (after reverse protection) for charge pump and H-bridge
26	L2	O	Gate voltage H-bridge, low-side 2
27	L1	O	Gate voltage H-bridge, low-side 1
28	PGND	I	Power ground for H-bridge and charge pump
29	VCC	O	5V/100 mA supply for microcontroller, blocking capacitor 2.2 μ F/10V/X7R
30	VBAT	I	Supply voltage for IC core (after reverse protection)
31	VBATSW	O	100 Ω PMOS switch from V _{BAT}
32	TP2	–	Test pin to be connected to GND

3. General Statement and Conventions

- Parameter values given without tolerances are indicative only and not to be tested in production
- Parameters given with tolerances but without a parameter number in the first column of parameter table are “guaranteed by design” (mainly covered by measurement of other specified parameters). These parameters are not to be tested in production. The tolerances are given if the knowledge of the parameter tolerances is important for the application
- The lowest power supply voltage is named GND
- All voltage specifications are referred to GND if not otherwise stated
- Sinking current means that the current is flowing into the pin (value is positive)
- Sourcing current means that the current is flowing out of the pin (value is negative)

3.1 Related Documents

- Qualification of integrated circuits according to Atmel[®] HNO procedure based on AEC-Q100
- AEC-Q100-004 and JESD78 (Latch-up)
- ESD STM 5.1-1998
- CEI 801-2 (only for information regarding ESD requirements of the PCB)

4. Application

4.1 General Remark

This chapter describes the principal application for which the ATA6824 was designed. Because Atmel cannot be considered to understand fully all aspects of the system, application and environment, no warranties of fitness for a particular purpose are given.

Table 4-1. Typical External Components (See also [Figure 1-1 on page 2](#))

Component	Function	Value	Tolerance
C_{VINT}	Blocking capacitor at VINT	220 nF, 10V, X7R	50%
C_{VCC}	Blocking capacitor at VCC	2.2 μ F, 10V, X7R	50%
C_{CC}	Cross conduction time definition capacitor	Typical 680 pF, 100V, COG	
R_{CC}	Cross conduction time definition resistor	Typical 10 k Ω	
C_{VG}	Blocking capacitor at VG	Typical 470 nF, 25V, X7R	50%
C_{CP}	Charge pump capacitor	Typical 220 nF, 25V, X7R	
C_{VRES}	Reservoir capacitor	Typical 470 nF, 25V, X7R	
R_{RWD}	Watchdog time definition resistor	Typical 51 k Ω	
C_{SIO}	Filter capacitor for SIO	Typical 220 pF, 100V	

5. Functional Description

5.1 Power Supply Unit with Supervisor Functions

5.1.1 Power Supply

The IC is supplied by a reverse-protected battery voltage. To prevent it from destruction, proper external protection circuitry has to be added. It is recommended to use at least a capacitor combination of storage and HF caps behind the reverse protection circuitry and closed to the VBAT pin of the IC (see [Figure 1-1 on page 2](#)).

An internal low-power and low drop regulator (V_{INT}), stabilized by an external blocking capacitor, provides the necessary low-voltage supply for all internal blocks except the digital IO pins. This voltage is also needed in the wake-up process. The low-power band gap reference is trimmed and is used for the bigger VCC regulator, too. All internal blocks are supplied by the internal regulator.

Note: The internal supply voltage V_{INT} must not be used for any other supply purpose!

Nothing inside the IC except the logic interface to the microcontroller is supplied by the 5V/3.3V VCC regulator.

A power-good comparator checks the output voltage of the V_{INT} regulator and keeps the whole chip in reset as long as the voltage is too low.

There is a high-voltage switch which brings out the battery voltage to the pin VBATSW for measurement purposes. This switch is switched ON for VCC = HIGH and stays ON in case of a watchdog reset. The signal can be used to switch on external voltage regulators, etc.

5.1.2 Voltage Supervisor

This block is intended to protect the IC and the external power MOS transistors against overvoltage on battery level and to manage undervoltage on it.

Function: in case of both overvoltage alarm (V_{THOV}) and of undervoltage alarm (V_{THUV}) the external NMOS motor bridge transistors will be switched off. The failure state will be flagged via DG2. No other actions will be carried out. The voltage supervision block is connected to VBAT and filtered by a first-order low pass with a corner frequency of typical 15 kHz.

5.1.3 Temperature Supervisor

There is a temperature sensor integrated on-chip to prevent the IC from overheating due to a failure in the external circuitry and to protect the external NMOSFET transistors.

In case of detected overtemperature (180°C), the diagnostic pin DG3 will be switched to “H” to signalize overtemperature warning to the microcontroller. It should undertake actions to reduce the power dissipation in the IC. In case of detected overtemperature (200°C), the V_{CC} regulator and all drivers including the serial interface will be switched OFF immediately and /RESET will go LOW.

Both temperature thresholds are correlated. The absolute tolerance is $\pm 15K$ and there is a built-in hysteresis of about 10K to avoid fast oscillations. After cooling down below the 170°C threshold; the IC will go into Active mode.

The occurrence of overtemperature shutdown is latched in DG3. DG3 stays on high until first WD trigger.

5.2 5V/3.3V VCC Regulator

The 5V/3.3V regulator is fully integrated on-chip. It requires only a 2.2 μF ceramic capacitor for stability and has 100 mA current capability. Using the VMODE pin, the output voltage can be selected to either 5V or 3.3V. Switching of the output voltage during operation is not intended to be supported. The VMODE pin must be hard-wired to either VINT for 5V or to GND for 3.3V. The logic HIGH level of the microcontroller interface will be adapted to the VCC regulator voltage.

The output voltage accuracy is in general $< \pm 3\%$; in the 5V mode with $V_{VBAT} < 9V$ it is limited to $< 5\%$.

To prevent destruction of the IC, the current delivered by the regulator is limited to maximum 100 mA to 350 mA. The delivered voltage will break down and a reset may occur.

Please note that this regulator is the main heat source on the chip. The maximum output current at maximum battery voltage and high ambient temperature can only be guaranteed if the IC is mounted on an efficient heat sink.

A power-good comparator checks the output voltage of the VCC regulator and keeps the external microcontroller in reset as long as the voltage is too low.

Figure 5-1. Voltage Dependence and Timing of VCC Controlled RESET

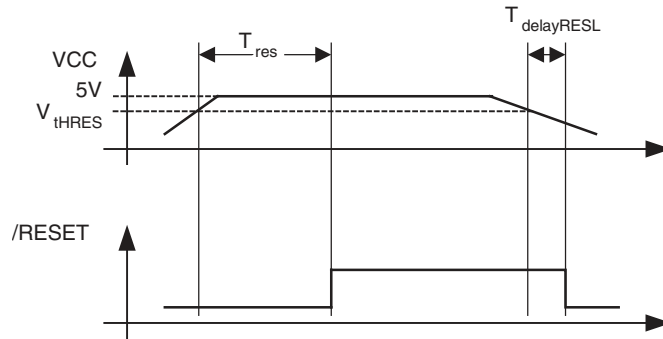
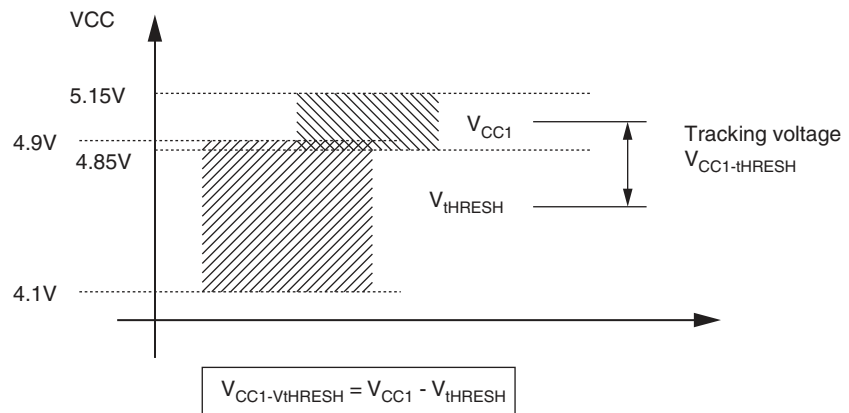


Figure 5-2. Correlation between VCC Output Voltage and Reset Threshold



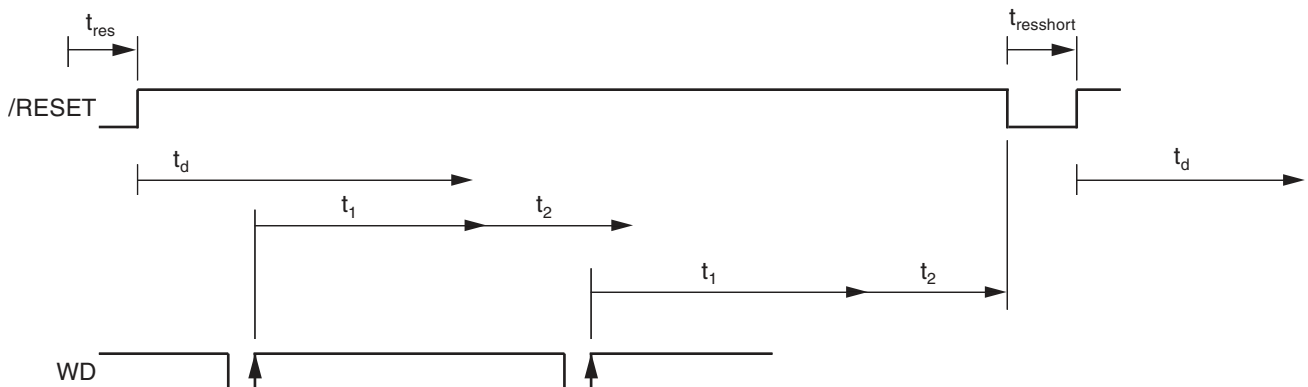
The voltage difference between the regulator output voltage and the upper reset threshold voltage is bigger than 75 mV (VMODE = HIGH) and bigger than 50 mV (VMODE = LOW).

5.3 Reset and Watchdog Management

The timing basis of the watchdog is provided by the trimmed internal oscillator. Its period T_{OSC} is adjustable via the external resistor R_{WD} .

The watchdog expects a triggering signal (a rising edge) from the microcontroller at the WD input within a period time window of T_{WD} .

Figure 5-3. Timing Diagram of the Watchdog Function



5.3.1 Timing Sequence

For example, with an external resistor $R_{WD} = 33 \text{ k}\Omega \pm 1\%$ we get the following typical parameters of the watchdog.

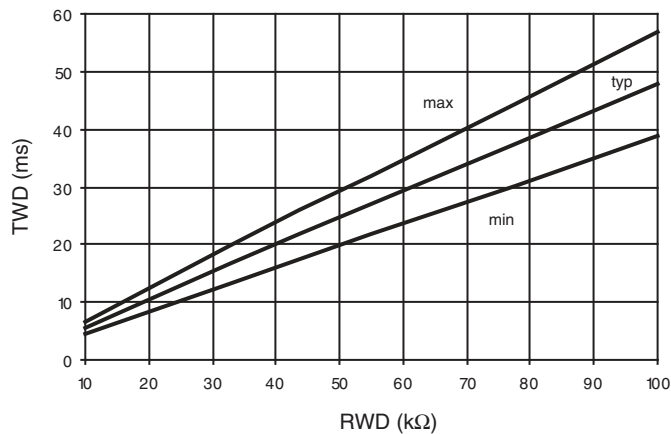
$$T_{OSC} = 12.32 \text{ }\mu\text{s}, t_1 = 12.1 \text{ ms}, t_2 = 9.61 \text{ ms}, T_{WD} = 16.88 \text{ ms} \pm 10\%$$

The times $t_{res} = 70 \text{ ms}$ and $t_d = 70 \text{ ms}$ are fixed values with a tolerance of 10%.

After ramp-up of the battery voltage (power-on reset), the V_{CC} regulator is switched on. The reset output, /RESET, stays low for the time t_{res} , then switches to high. For an initial lead time t_d (for setups in the controller) the watchdog waits for a rising edge on WD to start its normal window watchdog sequence. If no rising edge is detected, the watchdog will reset the microcontroller for t_{res} and wait t_d for the rising edge on WD.

Times t_1 (close window) and t_2 (open window) form the window watchdog sequence. To avoid receiving a reset from the watchdog, the triggering signal from the microcontroller must hit the timeframe of $t_2 = 9.61 \text{ ms}$. The trigger event will restart the watchdog sequence.

Figure 5-4. T_{WD} versus R_{WD}



If triggering fails, /RESET will be pulled to ground for a shortened reset time of typically 2 ms. The watchdog start sequence is similar to the power-on reset.

The internal oscillator is trimmed to a tolerance of $< \pm 10\%$. This means that t_1 and t_2 can also vary by $\pm 10\%$. The following calculation shows the worst case calculation of the watchdog period T_{wd} which the microcontroller has to provide.

$$t_{1min} = 0.90 \times t_1 = 10.87 \text{ ms}, t_{1max} = 1.10 \times t_1 = 13.28 \text{ ms}$$

$$t_{2min} = 0.90 \times t_2 = 8.65 \text{ ms}, t_{2max} = 1.10 \times t_2 = 10.57 \text{ ms}$$

$$T_{wdmax} = t_{1min} + t_{2min} = 10.87 \text{ ms} + 8.65 \text{ ms} = 19.52 \text{ ms}$$

$$T_{wdmin} = t_{1max} = 13.28 \text{ ms}$$

$$T_{wd} = 16.42 \text{ ms} \pm 3.15 \text{ ms} (\pm 19.1\%)$$

Figure 5-4 on page 8 shows the typical watchdog period T_{WD} depending on the value of the external resistor R_{OSC} .

A reset will be active for $V_{CC} < V_{thRESx}$; the level V_{thRESx} is realized with a hysteresis (HYS_{RESth}).

5.4 High Voltage Serial Interface

A bi-directional bus interface is implemented for data transfer between hostcontroller and the local microcontroller (SIO).

The transceiver consists of a low side driver (1.2V at 40 mA) with slew rate control, wave shaping, current limitation, and a high-voltage comparator followed by a debouncing unit in the receiver.

5.4.1 Transmit Mode

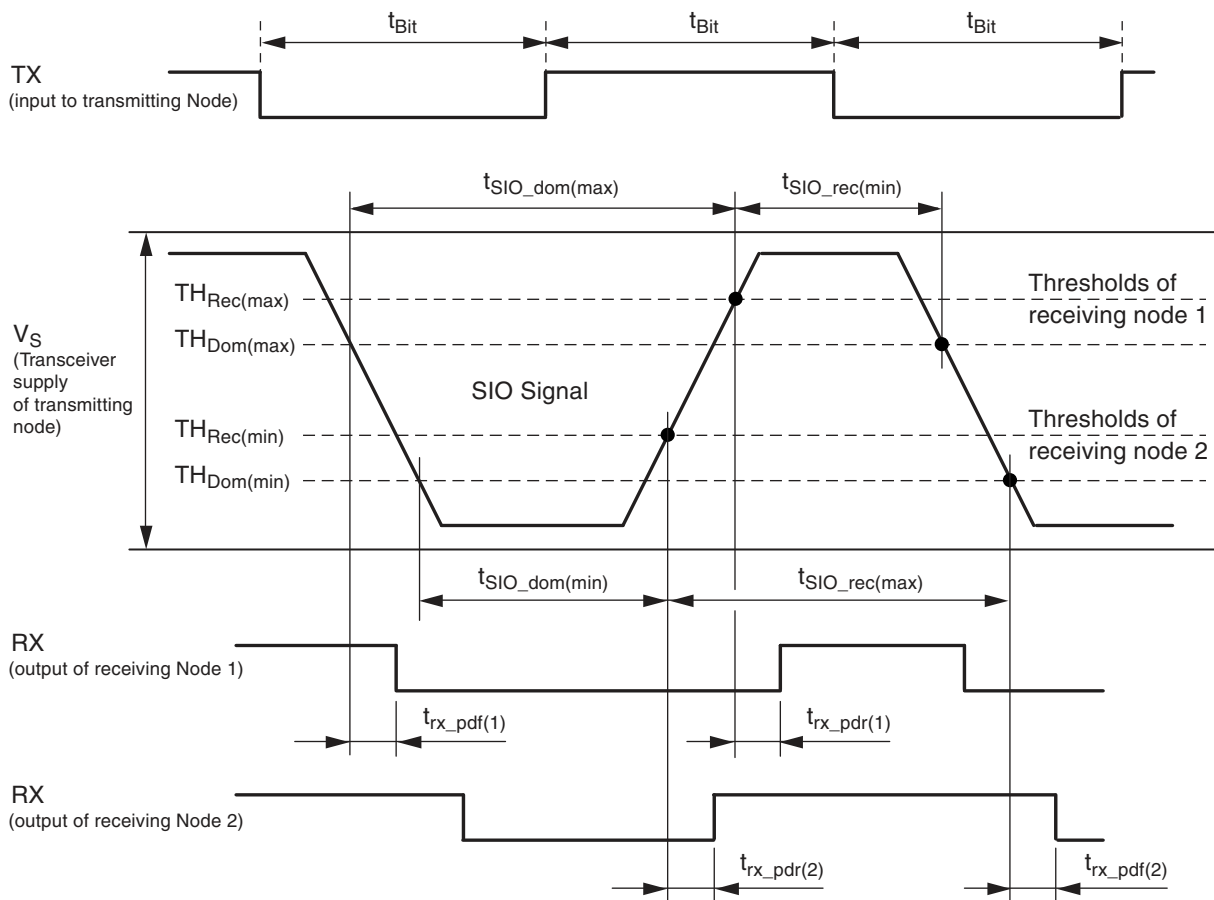
During transmission, the data at the pin TX will be transferred to the bus driver to generate a bus signal on pin SIO. The pin TX has a pull-down resistor included.

To minimize the electromagnetic emission of the bus line, the bus driver has an integrated slew rate control and wave-shaping unit. In transmit mode, transmission will be interrupted in case of overheating at the SIO driver.

5.4.2 Reset Mode

In case of an active reset shown at pin /RESET the pin SIO is switched to low, independent of the temperature. The maximum current is limited to $I_{SIO_LIM_RESET}$.

Figure 5-5. Definition of Bus Timing Parameters



The recessive BUS level is generated from the integrated 30 k Ω pull-up resistor in series with an active diode. This diode prevents the reverse current of VBUS during differential voltage between VSUP and BUS ($V_{BUS} > V_{SUP}$).

5.5 Control Inputs DIR and PWM

5.5.1 Pin DIR

Logical input to control the direction of the external motor to be controlled by the IC. An internal pull-down resistor is included.

5.5.2 Pin PWM

Logical input for PWM information delivered by external microcontroller. Duty cycle and frequency at this pin are passed through to the H-bridge. An internal pull-down resistor is included.

Table 5-1. Status of the IC Depending on Control Inputs and Detected Failures

Control Inputs			Driver Stage for External Power MOS				Comments
ON	DIR	PWM	H1	L1	H2	L2	
0	X	X	OFF	OFF	OFF	OFF	DG1, DG2 fault or RESET
1	0	PWM	ON	OFF	/PWM	PWM	Motor PWM forward
1	1	PWM	/PWM	PWM	ON	OFF	Motor PWM reverse

The internal signal ON is high when

- At least one valid WD trigger has been accepted
- Neither short circuit nor PBAT undervoltage detected
- V_{BAT} is inside the specified range ($V_{THUV} \leq V_{BAT} \leq V_{THOV}$)
- The charge pump has reached its minimum voltage
- The device temperature is not above shutdown threshold

In case of a short circuit, the appropriate transistor is switched off after a blanking time of t_{SC} . In order to avoid cross current through the bridge, a cross conduction timer is implemented. Its time constant is programmable by means of an RC combination.

Table 5-2. Status of the Diagnostic Outputs

Device Status						Diagnostic Outputs			Comments
PBAT_UV	SC	VBAT_UV	VBAT_OV	CPOK	OT	DG1	DG2	DG3	
X	X	X	X	X	1	–	–	1	Overtemperature warning
X	X	X	X	0	X	0	1	–	Charge pump failure
X	X	X	1	X	X	0	1	–	Overvoltage VBAT
X	X	1	X	X	X	0	1	–	Undervoltage VBAT
X	1	0	0	1	X	1	0	–	Short circuit
1	X	0	0	1	X	1	0	–	Undervoltage PBAT

Note: X represents: don't care – no effect)

PBAT_UV: Undervoltage PBAT pin
 SC: Short circuit drain source monitoring
 VBAT_UV: Undervoltage of VBAT pin
 VBAT_OV: Overvoltage of VBAT pin
 CPOK: Charge pump OK
 OT: Overtemperature warning

– Status of the diagnostic outputs depends on device status

5.6 VG Regulator

The VG regulator is used to generate the gate voltage for the low-side driver. Its output voltage will be used as one input for the charge pump, which generates the gate voltage for the high-side driver. The purpose of the regulator is to limit the gate voltage for the external power MOS transistors to 12V. It needs a ceramic capacitor of 470 nF for stability. The output voltage is reduced if the supply voltage at VBAT falls below 12V.

5.7 Charge Pump

The integrated charge pump is needed to supply the gates of the external power MOS transistors. It needs a shuffle capacitor of 220 nF and a reservoir capacitor of 470 nF. Without load, the output voltage on the reservoir capacitor is V_{VBAT} plus VG. The charge pump is clocked with a dedicated internal oscillator of 100 KHz. The charge pump is designed to reach a good EMC level. The charge pump will be switched off for $V_{VBAT} > V_{THOV}$.

5.8 Thermal Shutdown

There is a thermal shutdown block implemented. With rising junction temperature, a first warning level will be reached at 180°C. At this point the IC stays fully functional and a warning will be sent to the microcontroller. At junction temperature 200°C the drivers for H1, H2, L1, L2, SIO and the VCC regulator will be switched off and a reset occurs.

5.9 H-bridge Driver

The IC includes two push-pull drivers for control of two external power NMOS used as high-side drivers and two push-pull drivers for control of two external power NMOS used as low-side drivers. The drivers are able to be used with standard and logic-level power NMOS.

The drivers for the high-side control use the charge pump voltage to supply the gates with a voltage of VG above the battery voltage level. The low-side drivers are supplied by VG directly. It is possible to control the external load (motor) in the forward and reverse direction (see [Table 5-1 on page 10](#)). The duty cycle of the PWM controls the speed. A duty cycle of 100% is possible in both directions.

5.9.1 Cross Conduction Time

To prevent high peak currents in the H-bridge, a non-overlapping phase for switching the external power NMOS is realized. An external RC combination defines the cross conduction time in the following way:

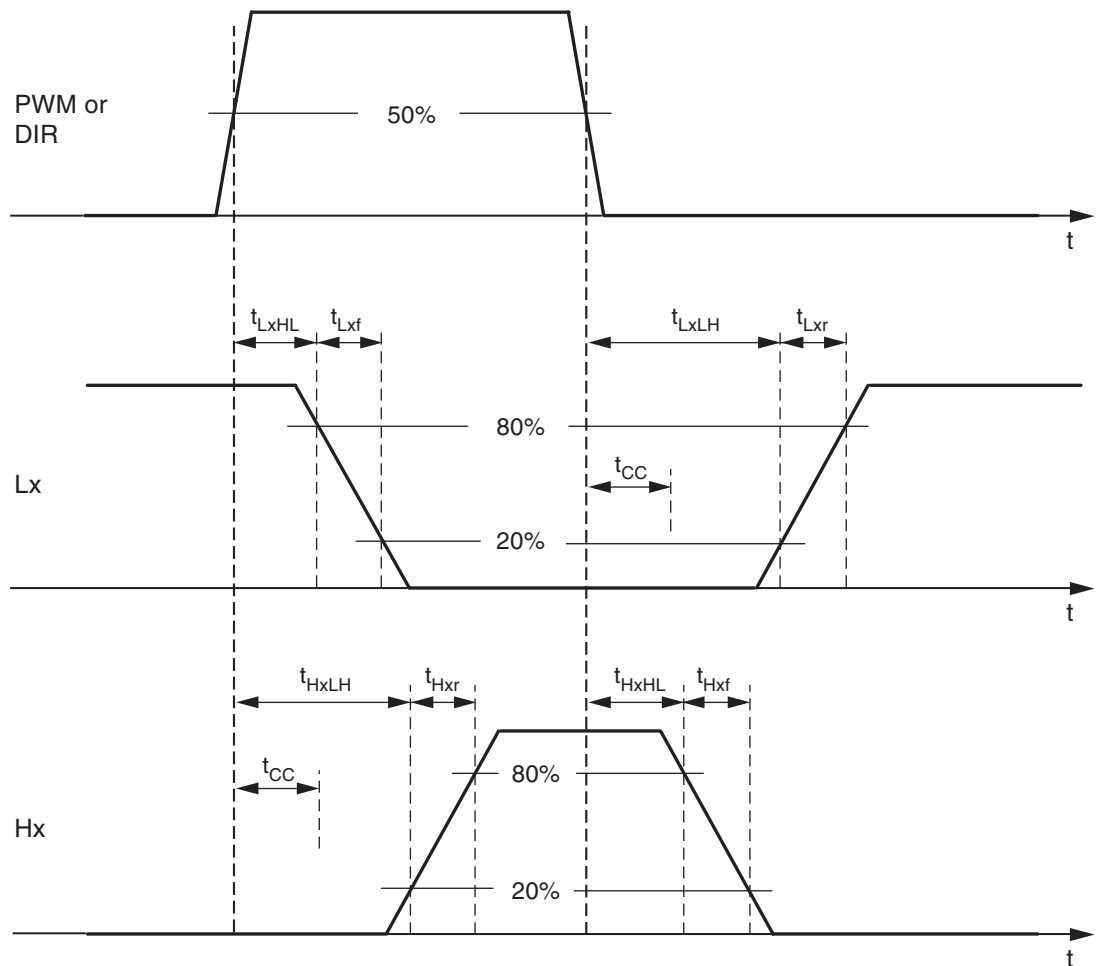
$$t_{CC} (\mu s) = 0.41 \times R_{CC} (k\Omega) \times C_{CC} (nF) \text{ (tolerance: } \pm 5\% \pm 0.15 \mu s)$$

The RC combination is charged to 5V and the switching level of the internal comparator is 67% of the start level.

The resistor R_{CC} must be greater than 5 k Ω and should be as close as possible to 10 k Ω , the C_{CC} value has to be ≤ 5 nF. Use of COG capacitor material is recommended.

The time measurement is triggered by the PWM or DIR signal crossing the 50% level.

Figure 5-6. Timing of the Drivers



The delays t_{HxLH} and t_{LxLH} include the cross conduction time t_{CC} .

5.10 Short Circuit Detection

To detect a short in H-bridge circuitry, internal comparators detect the voltage difference between source and drain of the external power NMOS. If the transistors are switched ON and the source-drain voltage difference is higher than the value V_{SC} (4V with tolerances) the diagnosis pin DG1 will be set to 'H' and the drivers will be switched off. All gate driver outputs (Hx and Lx) will be set to 'L'. Releasing the gate driver outputs will set DG1 back to 'L'. With the next transition on the pin PWM, the corresponding drivers, depending on the DIR pin, will be switched on again.

There is a PBAT supervision block implemented to detect the possible voltage drop on PBAT during a short circuit. If the voltage at PBAT falls under V_{PBAT_OK} the drivers will be switched off and DG1 will be set to "H". It will be cleared as soon as the PBAT undervoltage condition disappears.

The detection of drain source voltage exceedances is activated after the short circuit blanking time t_{SC} , the short circuit detection of PBAT failures operates immediately.

6. Absolute Maximum Ratings

Stresses beyond those listed under “Absolute Maximum Ratings” may cause permanent damage to the device. This is a stress rating only and functional operation of the device at these or any other conditions beyond those indicated in the operational sections of this specification is not implied. Exposure to absolute maximum rating conditions for extended periods may affect device reliability.

Pin Description	Pin Name	Min	Max	Unit
Ground	GND	0	0	V
Power ground	PGND	-0.3	+0.3	V
Reverse protected battery voltage	VBAT		+40	V
Reverse current out of pin	VBAT	-1		mA
Reverse protected battery voltage	PBAT		+40	V
Reverse current out of pin	PBAT	-500		mA
Digital output	/RESET	-0.3	$V_{VCC} + 0.3$	V
Digital output	DG1, DG2, DG3	-0.3	$V_{VCC} + 0.3$	V
4.9V output, external blocking capacitor	VINT	-0.3	+5.5	V
Cross conduction time capacitor/resistor combination	CC	-0.3	$V_{VCC} + 0.3$	V
Digital input coming from microcontroller	WD	-0.3	$V_{VCC} + 0.3$	V
Watchdog timing resistor	RWD	-0.3	$V_{VCC} + 0.3$	V
Digital input direction control	DIR	-0.3	$V_{VCC} + 0.3$	V
Digital input PWM control + Test mode	PWM	-0.3	$V_{VCC} + 0.3$	V
5V regulator output	VCC	-0.3	+5.5	V
Digital input	VMODE	-0.3	$V_{VINT} + 0.3$	V
12V output, external blocking capacitor	VG	-0.3	+16	V
Digital output	RX	-0.3	$V_{VCC} + 0.3$	V
Digital input	TX	-0.3	$V_{VCC} + 0.3$	V
Serial interface data pin	SIO	-27 ⁽¹⁾	$V_{VBAT} + 2$	V
Source external high-side NMOS	S1, S2	-2	+30 +40 ⁽⁴⁾	V
Gates external low-side NMOS	L1, L2	$V_{PGND} - 0.3$	$V_{VG} + 0.3$	V
Gates of external high-side NMOS	H1, H2	$V_{Sx} - 1$ ⁽³⁾	$V_{Sx} + 16$ ⁽³⁾	V
Charge pump	CPLO	-0.3	$V_{PBAT} + 0.3$	V
Charge pump	CPHI	-0.3	$V_{VRES} + 0.3$	V
Charge pump output	VRES	-0.3	+40 ⁽⁵⁾	V
Switched VBAT	VBATSW	-0.3	$V_{VBAT} + 0.3$	V
Power dissipation	P_{tot}		1.4 ⁽²⁾	W
Storage temperature	ϑ_{STORE}	-55	+150	°C

- Notes:
1. For $V_{VBAT} \leq 13.5V$
 2. May be additionally limited by external thermal resistance
 3. $x = 1, 2$
 4. $t < 0.5s$
 5. Load dump of $t < 0.5s$ tolerated

7. Thermal Resistance

Parameters	Symbol	Value	Unit
Thermal resistance junction to heat slug	R_{thjc}	< 5	K/W
Thermal resistance junction to ambient when heat slug is soldered to PCB	R_{thja}	25	K/W

8. Operating Range

The operating conditions define the limits for functional operation and parametric characteristics of the device. Functionality outside these limits is not implied unless otherwise stated explicitly.

Parameters	Symbol	Min	Max	Unit
Operating supply voltage ⁽¹⁾	V_{VBAT1}	V_{THUV}	V_{THOV}	V
Operating supply voltage ⁽²⁾	V_{VBAT2}	6	< V_{THUV}	V
Operating supply voltage ⁽³⁾	V_{VBAT3}	4.5	< 6	V
Operating supply voltage ⁽⁴⁾	V_{VBAT4}	0	< 4.5	V
Operating supply voltage ⁽⁵⁾	V_{VBAT5}	> V_{THOV}	40	V
Junction temperature range under bias	T_j	-40	+200	°C
Normal functionality	T_a	-40	+150	°C
Normal functionality, overtemperature warning set	T_j	165	195	°C
Switch-off temperatures of drivers for H1, H2, L1, L2, SIO and of VCC regulator	T_j	185	215	°C

- Note:
1. Full functionality
 2. H-bridge drivers are switched off (undervoltage detection)
 3. H-bridge drivers are switched off, 5V/3.3V regulator with reduced parameters, RESET works correctly
 4. H-bridge drivers are switched off, 5V regulator not working, RESET not correct
 5. H-bridge drivers are switched off

9. Noise and Surge Immunity

Parameters	Test Conditions	Value
Conducted interferences	ISO 7637-1	Level 4 ⁽¹⁾
Interference suppression	IEC-CISPR25	Level 5
ESD (Human Body Model)	ESD S 5.1	2 kV ⁽²⁾
CDM (Charge Device Model)	ESD STM5.3.	500V

- Notes:
1. Test pulse 5: $V_{vbmax} = 40V$
 2. Exception: 1 kV at pin 8 (SIO)

10. Electrical Characteristics

All parameters given are valid for $V_{THUV} \leq V_{VBAT} \leq V_{THOV}$ and for $-40^{\circ}\text{C} \leq \vartheta_{\text{ambient}} \leq 150^{\circ}\text{C}$ unless stated otherwise.

No.	Parameters	Test Conditions	Pin	Symbol	Min	Typ	Max	Unit	Type*
1	Power Supply and Supervisor Functions								
1.1	Current consumption V_{VBAT}	$V_{VBAT} = 13.5\text{V}^{(1)}$	25, 30	I_{VBAT1}			7	mA	A
1.2	Internal power supply		2	V_{INT}	4.8	4.94	5.1	V	A
1.3	Band gap voltage		3	V_{BG}		1.235		V	A
1.4	Overvoltage threshold Up V_{VBAT}		30	V_{THOV_UP}	21.2		22.7	V	A
1.4.1	Overvoltage threshold Down V_{VBAT}		30	V_{THOV_DOWN}	19.8		21.3	V	A
1.5	Overvoltage threshold hysteresis V_{VBAT}		30	V_{TOVhys}	1		2.4	V	A
1.6	Undervoltage threshold Up V_{VBAT}		30	V_{THUV_UP}	6.8		7.4	V	A
1.6.1	Undervoltage threshold Down V_{VBAT}		30	V_{THUV_DOWN}	6.5		7.0	V	A
1.7	Undervoltage threshold hysteresis V_{VBAT}	Measured during qualification only	30	V_{TUVhys}	0.2		0.6	V	A
1.8	On resistance of V_{VBAT} switch	$V_{VBAT} = 13.5\text{V}$	31	R_{ON_VBATSW}			100	Ω	A
1.9	Undervoltage threshold PBAT	$V_{VBAT} = 13.5\text{V}$	25	V_{PBAT_OK}	6.1		7	V	A
1.10	Undervoltage threshold hysteresis PBAT	$V_{VBAT} = 13.5\text{V}$	25	$V_{PBAT_OK_HYST}$	0		100	mV	A
2	5V/3.3V Regulator								
2.1	Regulated output voltage	$9\text{V} < V_{VBAT} < 40\text{V}$, $I_{load} = 0\text{ mA to } 100\text{ mA}$	29	V_{CC1}	4.85 (3.2)		5.15 (3.4)	V	A
2.2	Regulated output voltage	$6\text{V} < V_{VBAT} \leq 9\text{V}$ $I_{load} = 0\text{ mA to } 100\text{ mA}$	29	V_{CC2}	4.75 (3.2)		5.25 (3.4)	V	A
2.2a	Regulated output voltage	$6\text{V} < V_{VBAT} \leq 9\text{V}$ $I_{load} = 0\text{ mA to } 80\text{ mA}$ $T_a > 125^{\circ}\text{C}$	29	V_{CC2}	4.75 (3.2)		5.25 (3.4)	V	A
2.3	Line regulation	$I_{load} = 0\text{ mA to } 100\text{ mA}$	29	DC line regulation		<1	50	mV	A
2.4	Load regulation	$I_{load} = 0\text{ mA to } 100\text{ mA}$	29	DC load regulation		<10	50	mV	A
2.5	Output current limitation	$V_{VBAT} > 6\text{V}$	29	I_{OS1}	100		350	mA	A

* Type: A = 100% tested, B = 100% correlation tested, C = Characterized on samples, D = Design parameter

- Notes:
1. DIR, PWM = high
 2. The use of X7R material is recommended
 3. For higher values, stability at zero load is not guaranteed
 4. Tested during qualification only
 5. Value depends on T_{100} ; function tested with digital test pattern
 6. Tested during characterization only
 7. Supplied by charge pump
 8. See section [“Cross Conduction Time”](#)
 9. Voltage between source-drain of external switching transistors in active case
 10. The short-circuit message will never be generated for switch-on time $< t_{sc}$
 11. See [Figure 5-5 on page 9](#) “Definition of Bus Timing Parameters”

10. Electrical Characteristics (Continued)

All parameters given are valid for $V_{THUV} \leq V_{VBAT} \leq V_{THOV}$ and for $-40^{\circ}\text{C} \leq \vartheta_{\text{ambient}} \leq 150^{\circ}\text{C}$ unless stated otherwise.

No.	Parameters	Test Conditions	Pin	Symbol	Min	Typ	Max	Unit	Type*
2.6	Serial inductance to C_{VCC} including PCB		29	ESL	1		20	nH	D
2.7	Serial resistance to C_{VCC} including PCB		29	ESR	0		0.5	Ω	D
2.8	Blocking cap at VCC	(2), (3)	29	C_{VCC}	1.1		3.3	μF	D
2.9	HIGH threshold VMODE		1	VMODE H			4.0	V	A
2.10	LOW threshold VMODE		1	VMODE L	0.7			V	A
3	VG Regulator								
3.1	Regulated output voltage	$V_{PBAT} \geq 14\text{V}$ $I_{\text{max}} = 20\text{ mA}$	24	V_{VG}	11		14	V	A
3.2	Regulated output voltage	$V_{PBAT} = 9\text{V}$ $I_{\text{max}} = 20\text{ mA}$	24	V_{VG}	7.0		9.0	V	A
4	Reset and Watchdog								
4.1	V_{CC} threshold voltage level for /RESET	VMODE = "H" (VMODE = "L")	29	V_{IHRESH}			4.9 (3.25)	V	A
4.1a	Tracking of reset threshold with regulated output voltage	VMODE = "H" (VMODE = "L")	29	$V_{VCC1-VIHRESH}$	75 (50)			mV	A
4.2	V_{CC} threshold voltage level for /RESET	VMODE = "H" (VMODE = "L")	29	V_{IHRESL}	4.3 (2.86)			V	A
4.3	Hysteresis of /RESET level	VMODE = "H" (VMODE = "L") ⁽⁴⁾	29	HYS_{RESth}	70	200	350 (240)	mV	A
4.4	Length of pulse at /RESET pin	⁽⁵⁾	5	t_{res}		7000		T_{100}	A
4.5	Length of short pulse at /RESET pin	⁽⁵⁾	5	$t_{resshort}$		200		T_{100}	A
4.6	Wait for the first WD trigger	⁽⁵⁾	5	t_d		7000		T_{100}	A
4.7	Time for $V_{CC} < V_{IHRESL}$ before activating /RESET	⁽⁴⁾	29	$t_{delayRESL}$	0.5		2	μs	C
4.8	Resistor defining internal bias currents for watchdog oscillator		3	R_{RWD}	10		91	k Ω	D
4.9	Watchdog oscillator period	$R_{RWD} = 33\text{ k}\Omega$	3	T_{OSC}	11.09		13.55	μs	A
4.11	Watchdog input low-voltage threshold		6	V_{ILWD}			$0.3 \times V_{VCC}$	V	A

* Type: A = 100% tested, B = 100% correlation tested, C = Characterized on samples, D = Design parameter

- Notes:
1. DIR, PWM = high
 2. The use of X7R material is recommended
 3. For higher values, stability at zero load is not guaranteed
 4. Tested during qualification only
 5. Value depends on T_{100} ; function tested with digital test pattern
 6. Tested during characterization only
 7. Supplied by charge pump
 8. See section "[Cross Conduction Time](#)"
 9. Voltage between source-drain of external switching transistors in active case
 10. The short-circuit message will never be generated for switch-on time $< t_{sc}$
 11. See [Figure 5-5 on page 9](#) "Definition of Bus Timing Parameters"

10. Electrical Characteristics (Continued)

All parameters given are valid for $V_{THUV} \leq V_{VBAT} \leq V_{THOV}$ and for $-40^{\circ}\text{C} \leq \vartheta_{\text{ambient}} \leq 150^{\circ}\text{C}$ unless stated otherwise.

No.	Parameters	Test Conditions	Pin	Symbol	Min	Typ	Max	Unit	Type*
4.12	Watchdog input high-voltage threshold		6	V_{IHWD}	$0.7 \times V_{VCC}$			V	A
4.13	Hysteresis of watchdog input voltage threshold		6	V_{hysWD}	0.3		0.8	V	A
4.14	Close window	(5)	6	t1		$980 \times T_{OSC}$			A
4.15	Open window	(5)	6	t2		$780 \times T_{OSC}$			A
4.16	Output low-voltage of /RESET	At $I_{OLRES} = 1 \text{ mA}$	5	V_{OLRES}			0.4	V	A
4.17	Internal pull-up resistor at pin /RESET		5	R_{PURES}	5	10	15	k Ω	A
5	High Voltage Serial Interface								
5.1	Low-level output current	Normal mode; $V_{SIO} = 0\text{V}$, $V_{RX} = 0.4\text{V}$	13	I_{LRX}	2			mA	A
5.2	High-level output current	Normal mode; $V_{SIO} = V_{VBAT}$ $V_{RX} = V_{CC} - 0.4\text{V}$	13	I_{HRX}	0.8			mA	A
5.4	Driver dominant voltage $V_{BUSdom_DRV_LoSUP}$	$V_{VBAT} = 7.3\text{V}$ $R_{load} = 500\Omega$	8	V_{LoSUP}			1.2	V	A
5.5	Driver dominant voltage $V_{BUSdom_DRV_HiSUP}$	$V_{VBAT} = 18\text{V}$ $R_{load} = 500\Omega$	8	V_{HiSUP}			2	V	A
5.6	Driver dominant voltage $V_{BUSdom_DRV_LoSUP}$	$V_{VBAT} = 7.3\text{V}$ $R_{load} = 1000\Omega$	8	V_{LoSUP_1k}	0.6			V	A
5.7	Driver dominant voltage $V_{BUSdom_DRV_HiSUP}$	$V_{VBAT} = 18\text{V}$ $R_{load} = 1000\Omega$	8	V_{HiSUP_1k}	0.8			V	A
5.8	Pull up resistor to VBAT	The serial diode is mandatory	8	R_{SIO}	20	30	60	k Ω	A
5.9	Current limitation	$V_{SIO} = V_{BAT_max}$	8	I_{SIO_LIM}	40		250	mA	A
5.9a	Current limitation in case of RESET and SIO overheat	$V_{SIO} = V_{BAT_max}$ RESET = high	8	$I_{SIO_LIM_RESET}$	30		100	mA	A
5.10	Input leakage current at the receiver including pull-up resistor as specified	Input leakage current driver off $V_{SIO} = 0\text{V}$ $V_{VBAT} = 12\text{V}$	8	$I_{SIO_PAS_dom}$	-1			mA	A

* Type: A = 100% tested, B = 100% correlation tested, C = Characterized on samples, D = Design parameter

- Notes:
- DIR, PWM = high
 - The use of X7R material is recommended
 - For higher values, stability at zero load is not guaranteed
 - Tested during qualification only
 - Value depends on T_{100} ; function tested with digital test pattern
 - Tested during characterization only
 - Supplied by charge pump
 - See section "[Cross Conduction Time](#)"
 - Voltage between source-drain of external switching transistors in active case
 - The short-circuit message will never be generated for switch-on time $< t_{sc}$
 - See [Figure 5-5 on page 9](#) "Definition of Bus Timing Parameters"

10. Electrical Characteristics (Continued)

All parameters given are valid for $V_{THUV} \leq V_{VBAT} \leq V_{THOV}$ and for $-40^{\circ}\text{C} \leq \vartheta_{\text{ambient}} \leq 150^{\circ}\text{C}$ unless stated otherwise.

No.	Parameters	Test Conditions	Pin	Symbol	Min	Typ	Max	Unit	Type*
5.11	Leakage current SIO recessive	Driver off $8\text{V} < V_{VBAT} < 18\text{V}$ $8\text{V} < V_{SIO} < 18\text{V}$ $V_{SIO} \geq V_{VBAT}$	8	$I_{SIO_PAS_rec}$			30	μA	A
5.12	Leakage current at ground loss Control unit disconnected from ground Loss of local ground must not affect communication in the residual network	$GND_{\text{Device}} = VS$ $V_{VBAT} = 12\text{V}$ $0\text{V} < V_{SIO} < 18\text{V}$	8	$I_{SIO_NO_gnd}$	-1		1	mA	A
5.13	Node has to sustain the current that can flow under this condition. Bus must remain operational under this condition	V_{VBAT} disconnected $V_{SUP_Device} = GND$ $0\text{V} < V_{SIO} < 18\text{V}$	8	I_{SIO}			100	μA	A
5.14	Center of receiver threshold	$V_{SIO_CNT} = (V_{th_dom} + V_{th_rec})/2$	8	V_{SIO_CNT}	0.475 VS	0.5 VS	0.525 VS	V	A
5.15	Receiver dominant state	$V_{EN} = 5\text{V}$	8	V_{SIOdom}			0.4 VS	V	A
5.16	Receiver recessive state	$V_{EN} = 5\text{V}$	8	V_{SIOrec}	0.6 VS			V	A
5.17	Receiver input hysteresis	$V_{HYS} = V_{th_rec} - V_{th_dom}$	8	V_{SIOhys}		0.1 VS	0.175 VS	V	A
5.18	Duty cycle 1	$TH_{Rec(max)} = 0.744 \times V_{VBAT}$ $TH_{Dom(max)} = 0.581 \times V_{VBAT}$ $V_{VBAT} = 7\text{V to } 18\text{V}$ $t_{Bit} = 50 \mu\text{s}$ $D1 = t_{sio_rec(min)} / 2 \times t_{Bit}^{(11)}$	8	D1	0.380				A
5.19	Duty cycle 2	$TH_{Rec(min)} = 0.422 \times V_{VBAT}$ $TH_{Dom(min)} = 0.284 \times V_{VBAT}$ $V_{VBAT} = 7\text{V to } 18\text{V}$ $t_{Bit} = 50 \mu\text{s}$ $D2 = t_{sio_rec(max)} / 2 \times t_{Bit}^{(11)}$	8	D2			0.600		A
5.20	Propagation delay of receiver	$t_{rec_pd} = \max(t_{rx_pdr}, t_{rx_pdf})^{(11)}$ $7\text{V} < V_{VBAT} < 18\text{V}$	8	t_{rx_pd}			6	μs	A
5.21	Symmetry of receiver propagation delay	$t_{rx_sym} = t_{rx_pdr} - t_{rx_pdf}^{(11)}$ $7\text{V} < V_{VBAT} < 18\text{V}$	8	t_{rx_sym}	-2		+2	μs	A

* Type: A = 100% tested, B = 100% correlation tested, C = Characterized on samples, D = Design parameter

- Notes:
1. DIR, PWM = high
 2. The use of X7R material is recommended
 3. For higher values, stability at zero load is not guaranteed
 4. Tested during qualification only
 5. Value depends on T_{100} ; function tested with digital test pattern
 6. Tested during characterization only
 7. Supplied by charge pump
 8. See section "Cross Conduction Time"
 9. Voltage between source-drain of external switching transistors in active case
 10. The short-circuit message will never be generated for switch-on time $< t_{sc}$
 11. See Figure 5-5 on page 9 "Definition of Bus Timing Parameters"

10. Electrical Characteristics (Continued)

All parameters given are valid for $V_{THUV} \leq V_{VBAT} \leq V_{THOV}$ and for $-40^{\circ}\text{C} \leq \vartheta_{\text{ambient}} \leq 150^{\circ}\text{C}$ unless stated otherwise.

No.	Parameters	Test Conditions	Pin	Symbol	Min	Typ	Max	Unit	Type*
6	Control Inputs DIR, PWM, WD, TX								
6.1	Input low-voltage threshold		10, 11, 6, 9	V_{IL}			$0.3 \times V_{VCC}$	V	A
6.2	Input high-voltage threshold		10, 11, 6, 9	V_{IH}	$0.7 \times V_{VCC}$			V	A
6.3	Hysteresis		10, 11, 6, 9	HYS	0.3	0.5	0.8	V	A
6.4	Pull-down resistor	DIR, PWM, WD, TX	10, 11, 6, 9	R_{PD}	25	50	140	k Ω	A
6.5	Rise/fall time		10, 11, 6, 9	t_{rf}			100	ns	A
7	Charge Pump								
7.1	Charge pump voltage	Load = 0A	21	VCP			$V_{VBAT} + V_{VG}$	V	A
7.2	Charge pump voltage	Load = 3 mA, $C_{CP} = 100$ nF	21	VCP	$V_{VBAT} + V_{VG} - 1$			V	A
7.3	Period charge pump oscillator		21	T_{100}	9		11	μs	A
7.4	CP load current in VG without CP load	Load = 0A	21	I_{VGCPz}			600	μA	A
7.5	CP load current in VG with CP load	Load = 3 mA, $C_{CP} = 100$ nF	21	I_{VGCP}			4	mA	A
7.6	Charge pump OK threshold UP	Reference: PBAT	21	V_{CPOK_UP}	5.3		6.3	V	A
7.7	Charge pump OK threshold DOWN	Reference: PBAT	21	V_{CPOK_DOWN}	4.5		5.5	V	A
7.8	Charge pump OK hysteresis		21	V_{CPOK_HYS}	0.3		1.3	V	A
8	H-bridge Driver								
8.1	Low-side driver HIGH output voltage		26, 27	V_{LxH}	$V_{VG} - 0.5\text{V}$		V_{VG}	V	A
8.2	ON-resistance of sink stage of pins L1, L2		26, 27	$R_{DS(on)_LxL}$, x = 1, 2			25	Ω	A
8.3	ON-resistance of source stage of pins L1, L2		26, 27	$R_{DS(on)_LxH}$, x = 1, 2			25	Ω	A

* Type: A = 100% tested, B = 100% correlation tested, C = Characterized on samples, D = Design parameter

- Notes:
1. DIR, PWM = high
 2. The use of X7R material is recommended
 3. For higher values, stability at zero load is not guaranteed
 4. Tested during qualification only
 5. Value depends on T_{100} ; function tested with digital test pattern
 6. Tested during characterization only
 7. Supplied by charge pump
 8. See section ["Cross Conduction Time"](#)
 9. Voltage between source-drain of external switching transistors in active case
 10. The short-circuit message will never be generated for switch-on time $< t_{sc}$
 11. See [Figure 5-5 on page 9](#) "Definition of Bus Timing Parameters"

10. Electrical Characteristics (Continued)

All parameters given are valid for $V_{THUV} \leq V_{VBAT} \leq V_{THOV}$ and for $-40^{\circ}\text{C} \leq \vartheta_{\text{ambient}} \leq 150^{\circ}\text{C}$ unless stated otherwise.

No.	Parameters	Test Conditions	Pin	Symbol	Min	Typ	Max	Unit	Type*
8.4	Output peak current at pins L1, L2, switched to LOW	$V_{Lx} = 3\text{V}$	26, 27	$I_{LxL},$ $x = 1, 2$	100			mA	A
8.5	Output peak current at pins L1, L2, switched to HIGH	$V_{Lx} = 3\text{V}$	26, 27	$I_{LxH},$ $x = 1, 2$			-100	mA	A
8.6	Pull-down resistance at pins L1, L2		26, 27	R_{PDLx} $x = 1, 2$	25		140	k Ω	A
8.7	ON-resistance of sink stage of pins H1, H2	$V_{Sx} = 0$	18, 20	$R_{DSON_HxL},$ $x = 1, 2$			25	Ω	A
8.8	ON-resistance of source stage of pins H1, H2	$V_{Sx} = V_{VBAT}$	18, 20	$R_{DSON_HxH},$ $x = 1, 2$			25	Ω	A
8.9	Output peak current at pins Hx, switched to LOW	$V_{VBAT} = 13.5\text{V}$ $V_{Sx} = V_{VBAT}$ $V_{Hx} = V_{VBAT} + 3\text{V}$	18, 20	$I_{HxL},$ $x = 1, 2$	100			mA	A
8.10	Output peak current at pins Hx, switched to HIGH	$V_{VBAT} = 13.5\text{V}$ $V_{Sx} = V_{VBAT}$ $V_{Hx} = V_{VBAT} + 3\text{V}$	18, 20	$I_{HxH},$ $x = 1, 2$			-100	mA	A
8.11	Static switch output low voltage at pins Hx and Lx	$V_{Sx} = 0\text{V}$ $I_{Hx} = 1\text{ mA}, I_{Lx} = 1\text{ mA}$	18, 20, 26, 27	V_{HxL}, V_{LxL} $x = 1, 2$			0.3	V	A
8.12	Static high-side switch output high-voltage pins H1, H2	$I_{Lx} = -10\ \mu\text{A}$ (PWM = static)	18, 20	$V_{HxHstat1}^{(7)}$	$V_{VBAT} +$ $V_{VG} - 1$		$V_{VBAT} +$ V_{VG}	V	A
8.13	Sink resistance between Hx and Sx	Switches off	17, 18, 19, 20	R_{PDHx}	25		140	k Ω	A
Dynamic Parameters									
8.15	Propagation delay time, low-side driver from high to low	Figure 5-6 on page 12 $V_{VBAT} = 13.5\text{V}$	26, 27	t_{LxHL}			0.5	μs	A
8.16	Propagation delay time, low-side driver from low to high	$V_{VBAT} = 13.5\text{V}$	26, 27	t_{LxLH}			$0.5 + t_{CC}$	μs	A
8.17	Fall time low-side driver	$V_{VBAT} = 13.5\text{V}$ $C_{Gx} = 5\text{ nF}$	26, 27	t_{Lxf}			0.5	μs	A
8.18	Rise time low-side driver	$V_{VBAT} = 13.5\text{V}$	26, 27	t_{Lxr}			0.5	μs	A
8.19	Propagation delay time, high-side driver from high to low	Figure 5-6 on page 12 $V_{VBAT} = 13.5\text{V}$	18, 20	t_{HxHL}			0.5	μs	A

* Type: A = 100% tested, B = 100% correlation tested, C = Characterized on samples, D = Design parameter

- Notes:
1. DIR, PWM = high
 2. The use of X7R material is recommended
 3. For higher values, stability at zero load is not guaranteed
 4. Tested during qualification only
 5. Value depends on T_{100} ; function tested with digital test pattern
 6. Tested during characterization only
 7. Supplied by charge pump
 8. See section [“Cross Conduction Time”](#)
 9. Voltage between source-drain of external switching transistors in active case
 10. The short-circuit message will never be generated for switch-on time $< t_{sc}$
 11. See [Figure 5-5 on page 9](#) “Definition of Bus Timing Parameters”

10. Electrical Characteristics (Continued)

All parameters given are valid for $V_{THUV} \leq V_{VBAT} \leq V_{THOV}$ and for $-40^{\circ}\text{C} \leq \vartheta_{\text{ambient}} \leq 150^{\circ}\text{C}$ unless stated otherwise.

No.	Parameters	Test Conditions	Pin	Symbol	Min	Typ	Max	Unit	Type*
8.20	Propagation delay time, high-side driver from low to high	$V_{VBAT} = 13.5\text{V}$	18, 20	t_{HxLH}			$0.5 + t_{CC}$	μs	A
8.21	Fall time high-side driver	$V_{VBAT} = 13.5\text{V}$, $C_{GX} = 5 \text{ nF}$	18, 20	t_{Hxf}			0.5	μs	A
8.22	Rise time high-side driver	$V_{VBAT} = 13.5\text{V}$	18, 20	t_{Hxr}			0.5	μs	A
8.24	External resistor		4	R_{CC}	5			$\text{k}\Omega$	D
8.25	External capacitor		4	C_{CC}			5	nF	D
8.26	R_{ON} of t_{CC} switching transistor		4	R_{ONCC}			200	Ω	A
8.27	Cross conduction time ⁽⁸⁾	$R_{CC} = 10 \text{ k}\Omega$ $C_{CC} = 1 \text{ nF}$	4	t_{CC}	3.75		4.45	μs	A
8.28	Short circuit detection voltage	⁽⁹⁾	17, 19	V_{SC}	3.5	4	4.7	V	A
8.29	Short circuit blanking time	⁽¹⁰⁾	17, 19	t_{SC}	5	10	15	μs	A
9	Diagnostic Outputs DG1, DG2, DG3								
9.1	Low level output current	$V_{DG} = 0.4\text{V}^{(6)}$	14, 15, 16	IL	2			mA	A
9.2	High level output current	$V_{DG} = V_{CC} - 0.4\text{V}^{(6)}$	14, 15, 16	IH	0.8			mA	A

* Type: A = 100% tested, B = 100% correlation tested, C = Characterized on samples, D = Design parameter

- Notes:
1. DIR, PWM = high
 2. The use of X7R material is recommended
 3. For higher values, stability at zero load is not guaranteed
 4. Tested during qualification only
 5. Value depends on T_{100} ; function tested with digital test pattern
 6. Tested during characterization only
 7. Supplied by charge pump
 8. See section [“Cross Conduction Time”](#)
 9. Voltage between source-drain of external switching transistors in active case
 10. The short-circuit message will never be generated for switch-on time $< t_{sc}$
 11. See [Figure 5-5 on page 9](#) “Definition of Bus Timing Parameters”

11. Errata

11.1 Faulty Pulse at DG1

A faulty pulse of approximately 100 ns appears at pin 16 (DG1) – signaling short circuit condition – under following circumstances:

General condition: PWM = HIGH

and

detected undervoltage of VBAT (signalized at pin 15 = DG2)

or

detected overvoltage of VBAT (signalized at pin 15 = DG2)

or

detected undervoltage of the charge pump (signalized at pin 15 = DG2)

or

overtemperature shutdown

11.2 Problem Fix/Workaround

Set software to ignore the faulty pulse.

12. Ordering Information

Extended Type Number	Package	Remarks
ATA6824-PNQW	QFN32, 5 mm × 5 mm	Pb-free
ATA6824-MFHW	TPQFP32, 7 mm × 7 mm	Pb-free

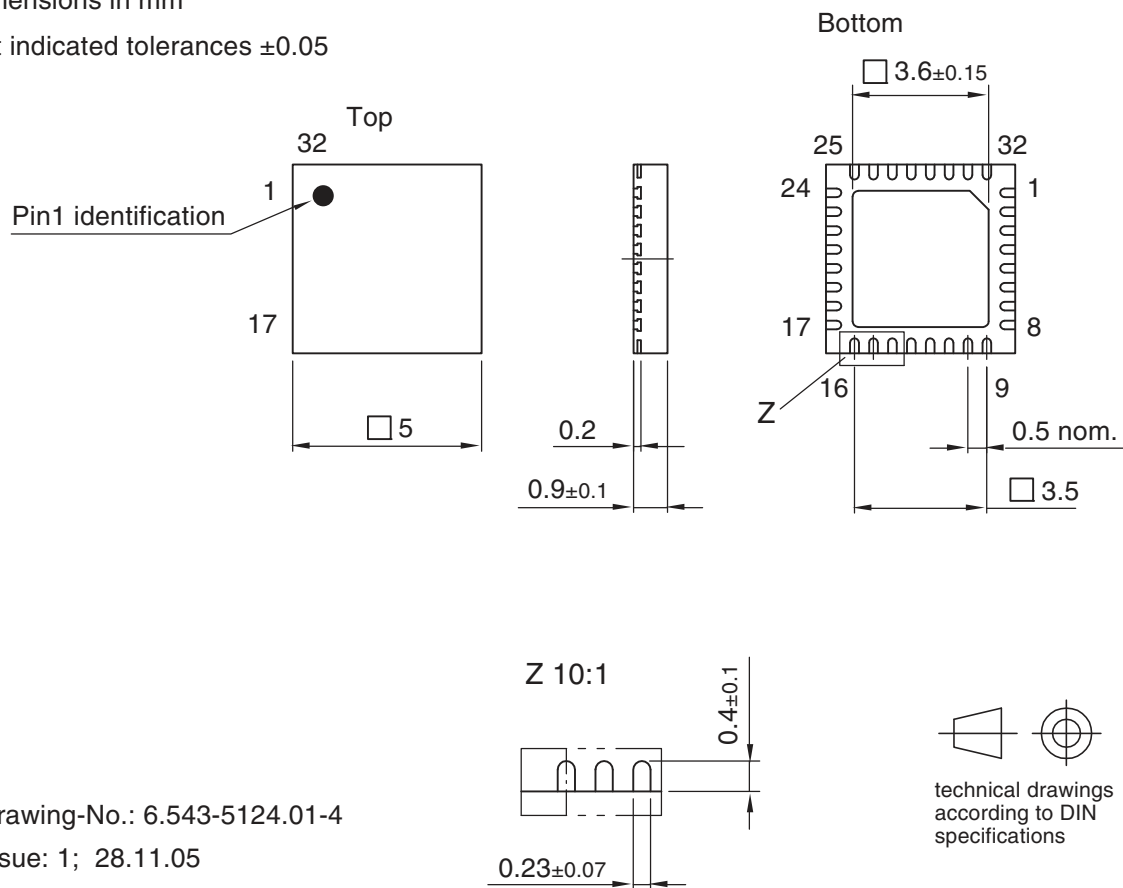
13. Package Information

Package: QFN_ 5 x 5_32L

Exposed pad 3.6 x 3.6

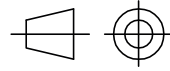
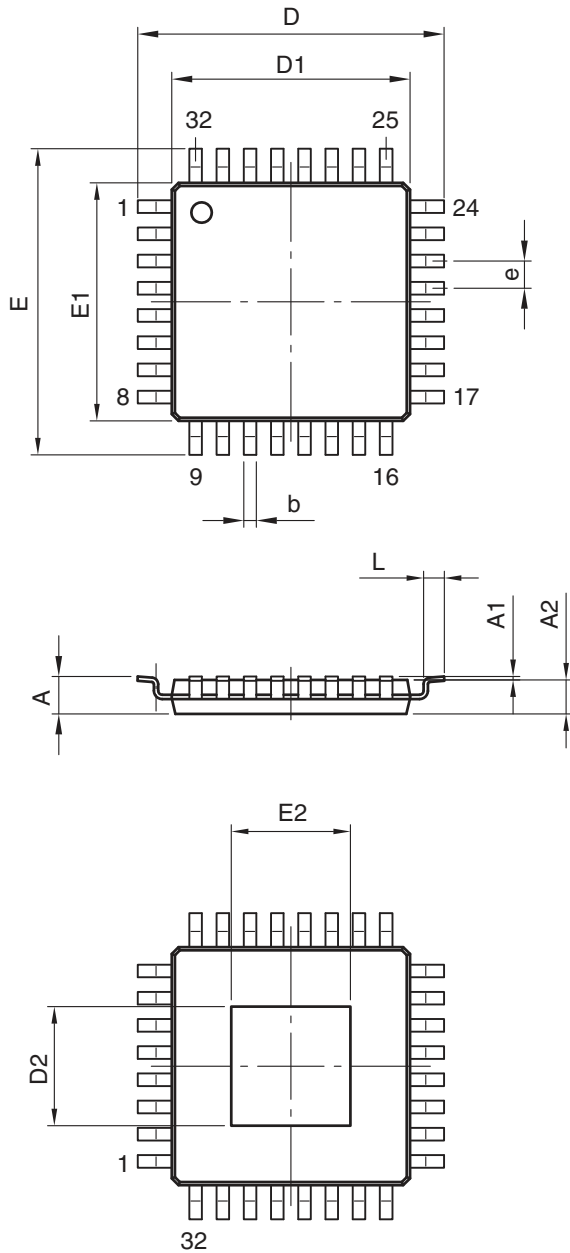
Dimensions in mm

Not indicated tolerances ±0.05



Drawing-No.: 6.543-5124.01-4

Issue: 1; 28.11.05



technical drawings
according to DIN
specifications

Dimensions in mm

COMMON DIMENSIONS				
(Unit of Measure = mm)				
Symbol	MIN	NOM	MAX	NOTE
A			1.2	
A1	0.05		0.15	
A2	0.95	1	1.05	
D		9 BSC		
D1		7 BSC		
D2		3.5 BSC		
E		9 BSC		
E1		7 BSC		
E2		3.5 BSC		
L	0.45	0.6	0.75	
N		32		
b	0.3	0.37	0.45	
3		0.8 BSC		

11/25/08



Package Drawing Contact:
packagedrawings@atmel.com

TITLE
Package: epad TPQFP32
(acc. JEDEC OUTLINE)

DRAWING NO.
6.543-5157.01-4

REV.
1

14. Revision History

Please note that the following page numbers referred to in this section refer to the specific revision mentioned, not to this document.

Revision No.	History
4931J-AUTO-02/10	<ul style="list-style-type: none"> • Section 5.1.3 “Temperature Supervisor” on page 6 changed • Section 5.4 “High Voltage Serial Interface” on page 9 changed • Section 5.5.2 “Pin PWM” on page 10 changed • Section 5.8 “Thermal Shutdown” on page 11 changed • Section 5.10 “Short Circuit Detection” on page 12 changed • Section 6 “Absolute Maximum Ratings” on page 13 changed • Section 8 “Operating Range” on page 14 changed • Section 10 “Electrical Characteristics” number 8.29 on page 21 changed
4931I-AUTO-12/09	<ul style="list-style-type: none"> • Section 5.1.3 “Temperature Supervisor” on page 6 changed • Section 5.3.1 “Timing Sequence” on page 8 changed • Section 5.4 “High Voltage Serial Interface” on page 9 changed • Section 5.5.2 “Pin PWM” on page 10 changed • Section 5.10 “Short Circuit Detection” on page 12 changed • Section 10 “Electrical Characteristics” numbers 4.4 and 4.6 on page 16 changed • Section 10 “Electrical Characteristics” number 5.9a on page 17 added • Section 10 “Electrical Characteristics” numbers 7.6 and 7.7 on page 19 changed • Section 10 “Electrical Characteristics” number 7.8 on page 19 added
4931H-AUTO-11/09	<ul style="list-style-type: none"> • Section 5.10 “Short Circuit Detection” on page 12 changed • Section 10 “Electrical Characteristics” numbers 1.9 and 1.10 on page 15 added
4931G-AUTO-04/09	<ul style="list-style-type: none"> • Section 9 “Noise and Surge Immunity” on page 14 changed
4931F-AUTO-02/09	<ul style="list-style-type: none"> • V_{VAT} to V_{VBAT} in whole document changed • V_{BAT} to V_{VBAT} in whole document changed • Features on page 1 changed • Section 1 “Description” on page 1 changed • Table 4-1 “Typical External Components (See also Figure 1-1 on page 2)” on page 5 changed • Figure 5-1 “Voltage Dependence and Timing of VCC Controlled RESET” on page 7 added • Figure 5-5 “Definition of Bus Timing Parameters” on page 9 changed • Section 5.7 “Charge Pump” on page 11 changed • Section 6 “Absolute Maximum Ratings” on page 13 changed • Section 8 “Operating Range” on page 14 changed • Section 10 “Electrical Characteristics” on pages 15 to 21 changed • Section 11 “Errata” on page 21 added • Section 12 “Ordering Information” on page 22 changed • Section 13 “Package Information” on page 22 changed
4931E-AUTO-01/08	<ul style="list-style-type: none"> • Section 5.2 “5V/3.3V VCC Regulator” on pages 6 to 7 changed • Section 5.4 “High Voltage Serial Interface” on page 9 changed • Section 10 “Electrical Characteristics” numbers 4.1a and 4.3 on page 16 changed



Headquarters

Atmel Corporation
2325 Orchard Parkway
San Jose, CA 95131
USA
Tel: 1(408) 441-0311
Fax: 1(408) 487-2600

International

Atmel Asia
Unit 1-5 & 16, 19/F
BEA Tower, Millennium City 5
418 Kwun Tong Road
Kwun Tong, Kowloon
Hong Kong
Tel: (852) 2245-6100
Fax: (852) 2722-1369

Atmel Europe
Le Krebs
8, Rue Jean-Pierre Timbaud
BP 309
78054
Saint-Quentin-en-Yvelines Cedex
France
Tel: (33) 1-30-60-70-00
Fax: (33) 1-30-60-71-11

Atmel Japan
9F, Tonetsu Shinkawa Bldg.
1-24-8 Shinkawa
Chuo-ku, Tokyo 104-0033
Japan
Tel: (81) 3-3523-3551
Fax: (81) 3-3523-7581

Product Contact

Web Site
www.atmel.com

Technical Support
auto_control@atmel.com

Sales Contact
www.atmel.com/contacts

Literature Requests
www.atmel.com/literature

Disclaimer: The information in this document is provided in connection with Atmel products. No license, express or implied, by estoppel or otherwise, to any intellectual property right is granted by this document or in connection with the sale of Atmel products. **EXCEPT AS SET FORTH IN ATMEL'S TERMS AND CONDITIONS OF SALE LOCATED ON ATMEL'S WEB SITE, ATMEL ASSUMES NO LIABILITY WHATSOEVER AND DISCLAIMS ANY EXPRESS, IMPLIED OR STATUTORY WARRANTY RELATING TO ITS PRODUCTS INCLUDING, BUT NOT LIMITED TO, THE IMPLIED WARRANTY OF MERCHANTABILITY, FITNESS FOR A PARTICULAR PURPOSE, OR NON-INFRINGEMENT. IN NO EVENT SHALL ATMEL BE LIABLE FOR ANY DIRECT, INDIRECT, CONSEQUENTIAL, PUNITIVE, SPECIAL OR INCIDENTAL DAMAGES (INCLUDING, WITHOUT LIMITATION, DAMAGES FOR LOSS OF PROFITS, BUSINESS INTERRUPTION, OR LOSS OF INFORMATION) ARISING OUT OF THE USE OR INABILITY TO USE THIS DOCUMENT, EVEN IF ATMEL HAS BEEN ADVISED OF THE POSSIBILITY OF SUCH DAMAGES.** Atmel makes no representations or warranties with respect to the accuracy or completeness of the contents of this document and reserves the right to make changes to specifications and product descriptions at any time without notice. Atmel does not make any commitment to update the information contained herein. Unless specifically provided otherwise, Atmel products are not suitable for, and shall not be used in, automotive applications. Atmel's products are not intended, authorized, or warranted for use as components in applications intended to support or sustain life.

© 2008 Atmel Corporation. All rights reserved. Atmel®, logo and combinations thereof, and others are registered trademarks or trademarks of Atmel Corporation or its subsidiaries. Other terms and product names may be trademarks of others.