

Thermally Protected High Voltage Linear Regulator

January 1996

Features

- Operates from 50V_{DC} to 400V_{DC}
- Operates from 50V_{RMS} to 280V_{RMS} Line
- UL Recognized
- Variable DC Output Voltage 1.2V_{DC} to V_{IN} - 50V
- Internal Thermal Shutdown Protection
- Internal Over Current Protection
- Up to 40mA Peak Output Current
- Surge Rated to ±650V; Meets IEEE/ANSI C62.41.1980 with Additional MOV

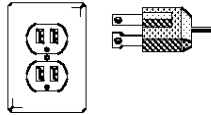

Description

The HIP5600 is an adjustable 3-terminal positive linear voltage regulator capable of operating up to either 400V_{DC} or 280V_{RMS}. The output voltage is adjustable from 1.2V_{DC} to within 50V of the peak input voltage with two external resistors. This high voltage linear regulator is capable of sourcing 1mA to 30mA with proper heat sinking. The HIP5600 can also provide 40mA peak (typical) for short periods of time.

Protection is provided by the on chip thermal shutdown and output current limiting circuitry. The HIP5600 has a unique advantage over other high voltage linear regulators due to its ability to withstand input to output voltages as high as 400V(peak), a condition that could exist under output short circuit conditions.

Common linear regulator configurations can be implemented as well as AC/DC conversion and start-up circuits for switch mode power supplies.

The HIP5600 requires a minimum output capacitor of 10μF for stability of the output and may require a 0.02μF input decoupling capacitor depending on the source impedance. It also requires a minimum load current of 1mA to maintain output voltage regulation.

All protection circuitry remains fully functional even if the adjustment terminal is disconnected. However, if this happens the output voltage will approach the input voltage.

Applications

- Switch Mode Power Supply Start-Up
- Electronically Commutated Motor Housekeeping Supply
- Power Supply for Simple Industrial/Commercial/Consumer Equipment Controls
- Off-Line (Buck) Switch Mode Power Supply

CAUTION: This product does not provide isolation from AC line.

Ordering Information

PART NUMBER	TEMP. RANGE	PACKAGE
HIP5600IS	-40°C to +100°C	3 Lead Plastic SIP
HIP5600IS2	-40°C to +100°C	3 Lead Gullwing Plastic SIP

Pinout

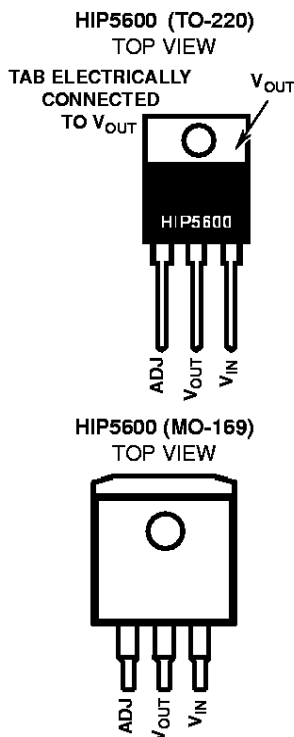

Functional Block Diagram

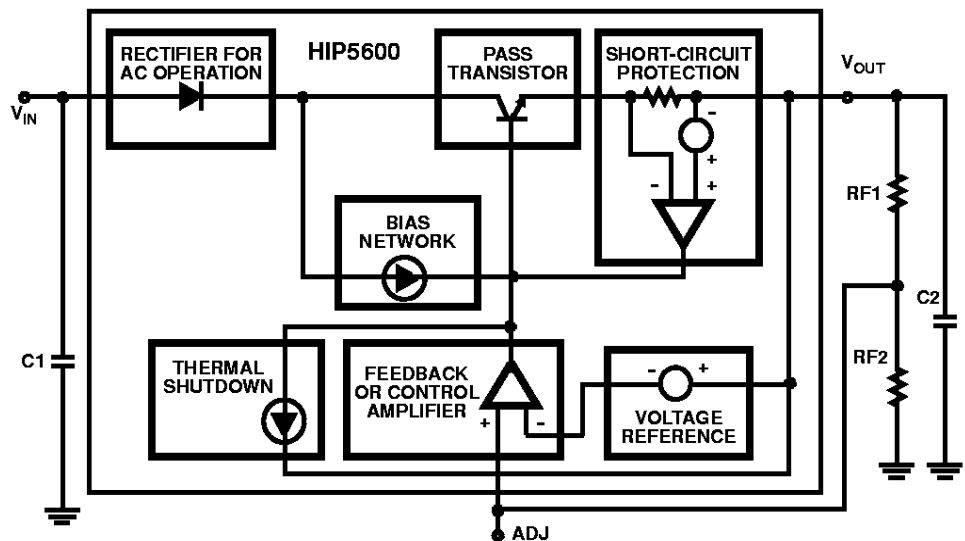

Specifications HIP5600

Absolute Maximum Ratings

Input to Output Voltage, Continuous	+480V to -550V
Input to Output Voltage, Peak (Non Repetitive, 2ms)	±650V
Junction Temperature	+150°C
ADJ to Output, Voltage to ADJ	±5V
Storage Temperature Range	-65°C to +150°C
Lead Temperature (Soldering 10s)	+265°C

Thermal Information (Typical)

Thermal Resistance	θ_{JA}	θ_{JC}
Plastic SIP Package	60°C/W	4°C/W

CAUTION: Stresses above those listed in "Absolute Maximum Ratings" may cause permanent damage to the device. This is a stress only rating and operation of the device at these or any other conditions above those indicated in the operational sections of this specification is not implied.

Operating Conditions

Operating Voltage Range	80V _{RMS} to 280V _{RMS} or 50V _{DC} to 400V _{DC}	Operating Temperature Range	-40°C to +100°C
-------------------------	---	-----------------------------	-----------------

Electrical Specifications Conditions $V_{IN} = 400V_{DC}$, $I_L = 1mA$, $C_L = 10\mu F$, $V_{ADJ} = 3.79V$, $V_{OUT} = 5V$ (Unless Otherwise Specified)
Temperature = Case Temperature.

PARAMETER	CONDITION	TEMP	MIN	TYP	MAX	UNITS
INPUT						
Input Voltage	DC	Full	50	-	400	V
Max Peak Input Voltage	Non-Repetitive (2ms)	Full	-	-	±650	V
Input Frequency (Note 1)		Full	DC	-	1000	Hz
Bias Current (I_{BIAS} Note 2)		Full	0.4	0.5	0.6	mA
REFERENCE						
I_{ADJ}		+25°C	50	65	80	μA
$I_{ADJ} T_C$ (Note 1)	$I_L = 1mA$	Full	-	+0.15	-	μA/°C
$I_{ADJ} \text{ LOAD REG}$ (Note 1)	$I_L = 1mA$ to 10mA	+25°C	-	-215	-	nA/mA
V_{REF} (Note 3)		+25°C	1.07	1.18	1.30	V
$V_{REF} T_C$ (Note 1)	$I_L = 1mA$	Full	-	-460	-	μV/°C
Line Regulation $V_{REF} \text{ LINE REG}$	50VDC to 400VDC	+25°C	-	9	14.5	μV/V
		Full	-	9	29	μV/V
Load Regulation $V_{REF} \text{ LOAD REG}$	$I_{OUT} = 1mA$ to 10mA	+25°C	-	3	5	mV/mA
		Full	-	3	6	mV/mA
PROTECTION CIRCUITS						
Output Short Circuit Current Limit	$V_{IN} = 50V$	+25°C	35	-	45	mA
Thermal Shutdown T_{TS} (IC surface, not case temperature. Note 1)	$V_{IN} = 400V$	-	127	134	142	°C
Thermal Shutdown Hysteresis (Note 1)	$V_{IN} = 400V$	-	-	34	-	°C

NOTES:

1. Characterized not tested
2. Bias current = input current with output pin floating.
3. $V_{REF} = V_{OUT} - V_{ADJ}$

Schematic Diagram

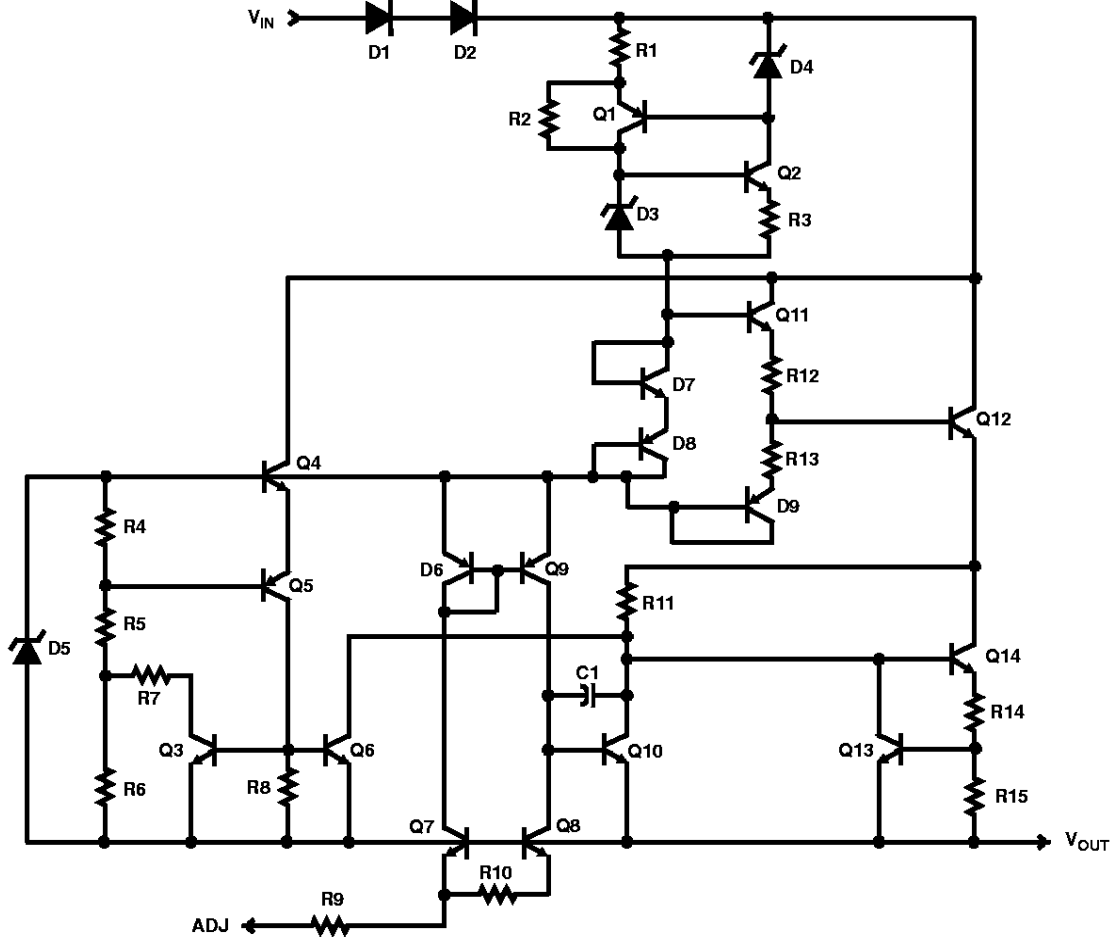

FIGURE 1.

Application Information

Introduction

In many electronic systems the components operate at 3V to 15V but the system obtains power from a high voltage source (AC or DC). When the current requirements are small, less than 10mA, a linear regulator may be the best supply provided that it is easy to design in, reliable, low cost and compact. The HIP5600 is similar to other 3 terminal regulators but operates from much higher voltages. It protects its load from surges +250V above its 400V operating input voltage and has short circuit current limiting and thermal shutdown self protection features.

Output Voltage

The HIP5600 provides a temperature independent 1.18V reference, V_{REF} , between the output and the adjustment terminal ($V_{REF} = V_{OUT} - V_{ADJ}$). This constant reference voltage is impressed across $RF1$ (see Figure 2) and results in a constant current (I_1) that flows through $RF2$ to ground. The voltage across $RF2$ is the product of its resistance and the sum of I_1 and I_{ADJ} . The output voltage is given in Equations 1(A, B).

$$V_{OUT} = (V_{REF}) \frac{RF1 + RF2}{RF1} + I_{ADJ} (RF2) \quad (EQ. 1A)$$

$$V_{OUT} = (1.18) \times \frac{RF1 + RF2}{RF1} + 65\mu A (RF2) \quad (EQ. 1B)$$

Error Budget

$$\Delta V_{OUT} = \Delta V_{REF}^T \left(\frac{RF1 + RF2}{RF1} \right) + \Delta I_{ADJ}^T RF2 + I_{ADJ} RF2 \frac{\Delta RF2}{RF2} + V_{REF} \left(\frac{RF2}{RF1} \right) \left(\frac{\Delta RF2}{RF2} - \frac{\Delta RF1}{RF1} \right) \quad (EQ. 2A)$$

Where;

$$\Delta V_{REF}^T \equiv \Delta V_{REF} + V_{REF_LOADREG} (\Delta I_{OUT}) + V_{REF_TC} (\Delta Temp) + V_{REF_TC} (\theta_{SA}) \Delta (I_{OUT} \cdot V_{IN}) + V_{REF_LINEREG} \quad (EQ. 2B)$$

$$\Delta I_{ADJ}^T \equiv \Delta I_{ADJ} + I_{ADJ_LOADREG} (\Delta I_{OUT}) + I_{ADJ_TC} (\Delta Temp) + I_{ADJ_TC} (\theta_{SA}) \Delta (I_{OUT} \cdot V_{IN}) \quad (EQ. 2C)$$

Note:

$$\frac{\Delta RFx}{RFx} = \% \text{ tolerance of resistor } x$$

Equations 2(A,B,C) are provided to determine the worst case output voltage in relation to; manufacturing tolerances (ΔV_{REF} and ΔI_{REF}), % tolerance in external resistors ($\Delta R_{F1}/R_{F1}$, $\Delta R_{F2}/R_{F2}$), load regulation ($V_{REF\ LOAD\ REG}$, $I_{ADJ\ LOAD\ REG}$), line regulation ($V_{REF\ LINE\ REG}$) and the effects of temperature ($V_{REF\ TC}$, $I_{REF\ TC}$), which includes self heating (θ_{SA}).

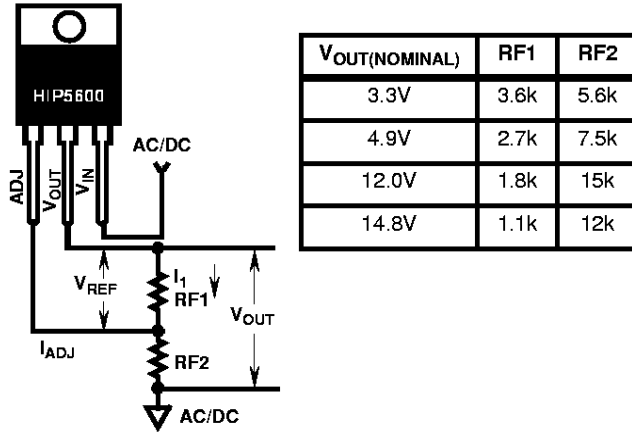

FIGURE 2.

Example: Given: $V_{IN} = 200V_{DC}$, $V_{OUT} = 15V$, $I_{OUT} = 2mA$ to $12mA$, $\theta_{SA} = 10^{\circ}C/W$, $RF1 = 1.1k\Omega$ 5% low, $RF2 = 12k\Omega$ 5% high, ΔI_{OUT} equals $10mA$ and $\Delta Temp$ equals $+60^{\circ}C$ (ambient temperature $+25^{\circ}C$ to $+85^{\circ}C$). The worst case ΔV_{OUT} for the given conditions is $-1.13V$. The shift in V_{OUT} is attributed to the following: $-1.55V$ manufacturing tolerances, $+1.33V$ external resistors, $-0.62V$ load regulation and $-0.29V$ temperature effects.

Regulator With Zener

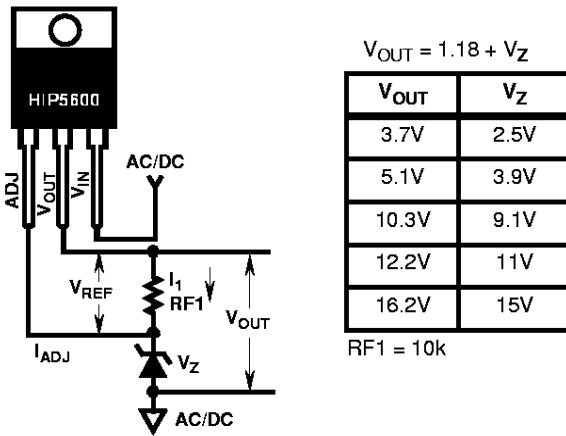

FIGURE 3.

The output voltage can be set by using a zener diode (Figure 3) instead of the resistor divider shown in Figure 2. The zener diode improves the ripple rejection ratio and reduces the value of the worst case output voltage, as illustrated in the example to follow. The bias current of the zener diode is set by the value of $RF1$ and I_{ADJ} .

The regulator / zener diode becomes an attractive solution if ripple rejection or the worst case tolerance of the output voltage is critical (i.e. one zener diode cost less than one $10\mu F$

capacitor (C3) and one $1/4W$ resistor $RF2$). Minimum power dissipation is possible by reducing I_1 current, with little effect on the output voltage regulation. The output voltage is given in Equation 3.

$$V_{OUT} = V_{REF} + V_Z \quad (EQ. 3)$$

Error Budget

$$\Delta V_{OUT} = \Delta V_{REF} + \Delta V_{T_Z} \quad (EQ. 4A)$$

$$\Delta V_{REF} \equiv \Delta V_{REF} + V_{REF\ LOAD\ REG} (\Delta I_{OUT}) + V_{REF\ TC} (\Delta Temp) + V_{REF\ TC} (\theta_{SA}) \Delta (I_{OUT} \cdot V_{IN}) + V_{REF\ LINE\ REG} \quad (EQ. 4B)$$

$$\Delta V_{T_Z} \equiv V_{Z\ tolerance} (V_Z) + V_{Z\ TC} (\Delta Temp) \quad (EQ. 4C)$$

Equations 4(A,B,C) are provided to determine the worst case output voltage in relation to; manufacturing tolerances of HIP5600 and the zener diode (ΔV_{REF} and ΔV_{T_Z}), load regulation of the HIP5600 ($V_{REF\ LOAD\ REG}$), and the effects of temperature on the HIP5600 and the zener diode ($V_{REF\ TC}$, $V_{Z\ TC}$).

Example: Given: $V_{IN} = 200V$, $V_{OUT} = 14.18V$ ($V_{REF} = 1.18V$, $V_Z = 13V$), $\Delta V_Z = 5\%$, $V_{Z\ TC} = +0.079\%/^{\circ}C$ (assumes 1N5243BPH), ΔI_{OUT} equal $10mA$ and $\Delta Temp$ equal $+60^{\circ}C$. The worst case ΔV_{OUT} is $0.4956V$. The shift in V_{OUT} is attributed to the following: -0.2 (HIP5600) and 0.69 (zener diode).

The regulator/zener diode configuration gives a 3.5% ($0.49/14.18$) worst case output voltage error where, for the same conditions, the regulator/resistor configuration results in an 7.5% ($1.129/15$) worst case output voltage error.

External Capacitors

A minimum $10\mu F$ output capacitor (C2) is required for stability of the output stage. Any increase of the load capacitance greater than $10\mu F$ will merely improve the loop stability and output impedance.

A $0.02\mu F$ input decoupling capacitor (C1) between V_{IN} and ground may be required if the power source impedance is not sufficiently low for the 1MHz - 10MHz band. Without this capacitor, the HIP5600 can oscillate at 2.5MHz when driven by a power source with a high impedance for the 1MHz - 10MHz band.

An optional bypass capacitor (C3) from V_{ADJ} to ground improves the ripple rejection by preventing the ripple at the Adjust pin from being amplified. Bypass capacitors larger than $10\mu F$ do not appreciably improve the ripple rejection of the part (see Figure 20 through Figure 25).

Load Regulation

For improved load regulation, resistor $RF1$ (connected between the adjustment terminal and V_{OUT}) should be tied directly to the output of the regulator (Figure 4A) rather than near the load Figure 4B. This eliminates line drops (R_S) from appearing effectively in series with $RF1$ and degrading regulation. For example, a 15V regulator with a 0.05Ω resistance

between the regulator and the load will have a load regulation due to line resistance of $0.05\Omega \times \Delta I_L$. If RF1 is connected near the load the effective load regulation will be 11.9 times worse ($1+R2/R1$, where $R2 = 12k$, $R1 = 1.1k$).

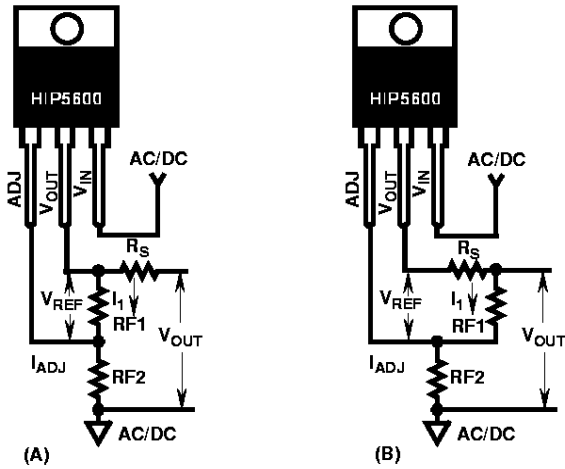

FIGURE 4.

Protection Diodes

The HIP5600, unlike other voltage regulators, is internally protected by input diodes in the event the input becomes shorted to ground. Therefore, **no** external protection diode is required between the input pin and the output pin to protect against the output capacitor (C2) discharging through the input to ground.

If the output is shorted in the absence of D1 (Figure 5), the bypass capacitor voltage (C3) could exceed the absolute maximum voltage rating of $\pm 5V$ between V_{OUT} and V_{IN} . Note; No protection diode (D1) is needed for output voltages less than 6V or if C3 is not used.

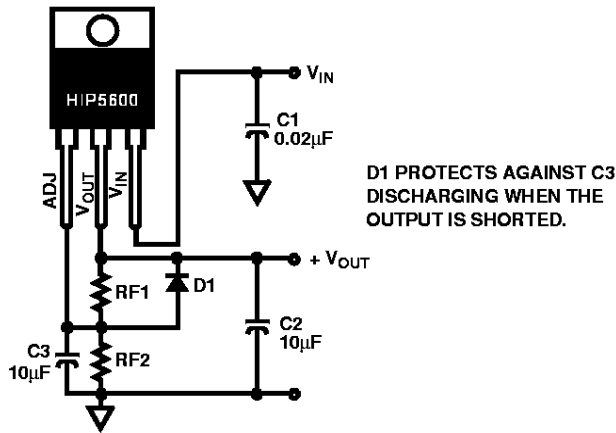

FIGURE 5. REGULATOR WITH PROTECTION DIODE

Selecting the Right Heat Sink

Linear power supplies can dissipate a lot of power. This power or heat must be safely dissipated to permit continuous operation. This section will discuss thermal resistance and show how to calculate heat sink requirements.

Electronic heat sinks are generally rated by their thermal resistance. Thermal resistance is defined as the temperature rise per unit of heat transfer or power dissipated, and is

expressed in units of degrees centigrade per watt. For a particular application determine the thermal resistance (θ_{SA}) which the heat sink must have in order to maintain a junction temperature below the thermal shut down limit (T_{TS}).

A thermal network that describes the heat flow from the integrated circuit to the ambient air is shown in Figure 6. The basic relation for thermal resistance from the IC surface, historically called "junction", to ambient (θ_{JA}) is given in Equation 5. The thermal resistance of the heat sink (θ_{SA}) to maintain a desired junction temperature is calculated using Equation 6.

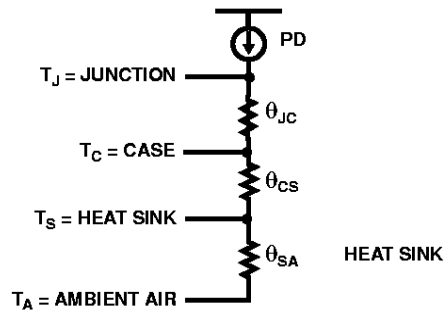

FIGURE 6.

$$\theta_{JA} = \frac{T_J - T_A}{P} \left(\frac{^{\circ}C}{W} \right) \tag{EQ. 5}$$

Where:

$$\theta_{JA} = \theta_{JC} + \theta_{CS} + \theta_{SA} \text{ and } T_J = T_{TS}$$

$$\therefore \theta_{SA} + \theta_{CS} \approx \theta_{SA} = \frac{T_{TS} - T_A}{P} - \theta_{JC} \tag{EQ. 6}$$

Where:

θ_{JA} = (Junction to Ambient Thermal Resistance) The sum of the thermal resistances of the heat flow path.

$$\theta_{JA} = \theta_{JC} + \theta_{CS} + \theta_{SA}$$

T_J = (Junction Temperature) The desired maximum junction temperature of the part. $T_J = T_{TS}$

T_{TS} = (Thermal Shutdown Temperature) The maximum junction temperature that is set by the thermal protection circuitry of the HIP5600 (min = +127°C, typ = +134°C and max = +142°C).

θ_{JC} = (Junction to Case Thermal Resistance) Describes the thermal resistance from the IC surface to its case. $\theta_{JC} = 4.8^{\circ}C/W$

θ_{CS} = (Case to Mounting Surface Thermal Resistance) The resistance of the mounting interface between the transistor case and the heat sink. For example, mica washer.

θ_{SA} = (Mounting Surface to Ambient Thermal Resistance) The resistance of the heat sink to the ambient air. Varies with air flow.

T_A = Ambient Temperature

P = The power dissipated by the HIP5600 in watts.

$$P = (V_{IN} - V_{OUT})(I_{OUT})$$

Worst case θ_{SA} is calculated using the minimum T_{TS} of $+127^{\circ}\text{C}$ in Equation 6.

Example,

Given: $V_{IN} = 400\text{V}_{DC}$ $V_{OUT} = 15\text{V}$ $I_{LOAD} = 15\text{mA}$
 $\theta_{JC} = 4.8^{\circ}\text{C/W}$ $T_{TS} = +127^{\circ}\text{C}$ $I_{ADJ} = 80\mu\text{A}$
 $T_A = +50^{\circ}\text{C}$ $R_{F1} = 1.1\text{k}$
 $V_{REF} = 1.18\text{V}$ $P = 6.2\text{W} = (V_{IN} - V_{OUT})(I_{IN})$

$$I_{IN} = I_{ADJ} + \frac{V_{REF}}{R_{F1}} + I_{LOAD}$$

Find: Proper heat sink to keep the junction temperature of the HIP5600 from exceeding T_{TS} ($+127^{\circ}\text{C}$).

Solution: Use Equation 6,

$$\theta_{SA} = \frac{T_{TS} - T_A}{P} - \theta_{JC} \quad (\text{EQ. 7})$$

$$\theta_{SA} = \frac{127^{\circ}\text{C} - 50^{\circ}\text{C}}{6.2} - 4.8^{\circ}\text{C} = 7.62 \frac{^{\circ}\text{C}}{\text{W}} \quad (\text{EQ. 8})$$

The selection of a heat sink with θ_{SA} less than $+7.62^{\circ}\text{C/W}$ would ensure that the junction temperature would not exceed the thermal shut down temperature (T_{TS}) of $+127^{\circ}\text{C}$. A Thermalloy P/N7023 at 6.2W power dissipation would meet this requirement with a θ_{SA} of $+5.7^{\circ}\text{C/W}$.

Operation Without A Heatsink

The package has a θ_{JA} of $+60^{\circ}\text{C/W}$. This allows 0.7W power dissipation at $+85^{\circ}\text{C}$ in still air. Mounting the HIP5600 to a printed circuit board (see Figure 39 through Figure 41) decreases the thermal impedance sufficiently to allow about 1.6W of power dissipation at $+85^{\circ}\text{C}$ in still air.

Thermal Transient Operation

For applications such as start-up, the HIP5600 in the TO-220 package can operate at several watts **without a heat sink** for a period of time before going into thermal shutdown.

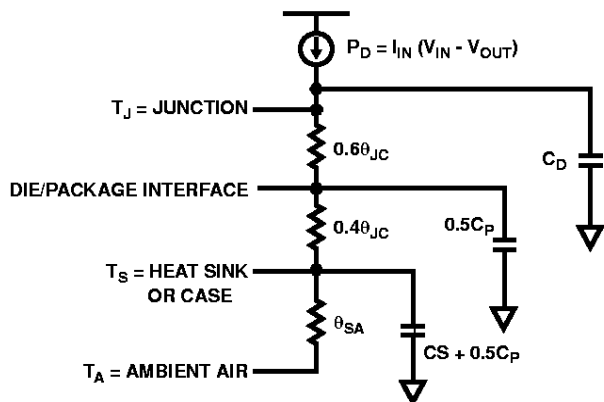

FIGURE 7. THERMAL CAPACITANCE MODEL OF HIP5600

Figure 7 shows the thermal capacitances of the TO-220 package, the integrated circuit and the heat sink, if used.

When power is initially applied, the mass of the package absorbs heat which limits the rate of temperature rise of the junction. With no heat sink C_S equals zero and θ_{SA} equals the difference between θ_{JA} and θ_{JC} . The following equations predict the transient junction temperature and the time to thermal shutdown for ambient temperatures up to $+85^{\circ}\text{C}$ and power levels up to 8W . The output current limit temperature coefficient (Figure 39) precludes continuous operation above 8W .

$$T_J(t) = T_A + P\theta_{JC} + P\theta_{SA} \left(1 - e^{-\frac{t}{\tau}} \right) \quad (\text{EQ. 9})$$

Where:

$$\tau = \theta_{SA} (C_P + C_S)$$

$$t = -\tau \ln \left(\frac{P(\theta_{JC} + \theta_{SA}) + T_A - T_{TS}}{P\theta_{SA}} \right) \quad (\text{EQ. 10})$$

For the TO-220, C_P is 0.9Ws to 1.1Ws per degree compared to about 2.6mWs per degree for the integrated circuit and C_S is 0.9Ws per degree per gram for aluminum heat sinks.

Figure 8 shows the time to thermal shutdown versus power dissipation for a part in $+22^{\circ}\text{C}$ still air and at various elevated ambient temperatures with a θ_{SA} of $+27^{\circ}\text{C/W}$ from forced air flow.

For the shorter shutdown times, the θ_{SA} value is not important but the thermal capacitances are. A more accurate equation for the transient silicon surface temperature can be derived from the model shown in Figure 7. Due to the distributed nature of the package thermal capacitance, the second time constant is 1.7 times larger than expected.

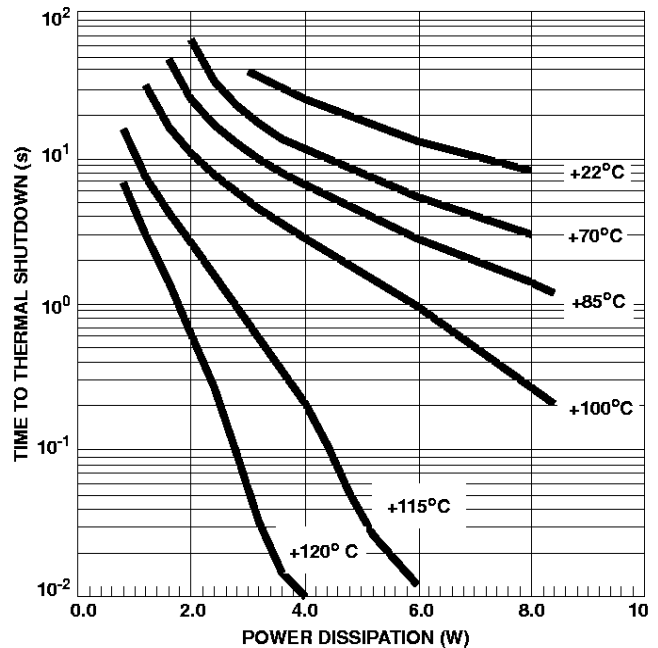

FIGURE 8. TIME TO THERMAL SHUTDOWN vs POWER DISSIPATION

$$T_J(t) = T_A + T_1 + T_2 + T_3 \quad (\text{EQ. 11A})$$

$$T_1 \equiv P\theta_{SA} \left(1 - e^{-\frac{t}{\tau_1}} \right)$$

Where: (EQ. 11B)

$$\tau_1 \equiv \theta_{SA} (C_P + C_S)$$

$$T_2 \equiv 0.4P\theta_{JC} \left(1 - e^{-\frac{t}{\tau_2}} \right) \quad (\text{EQ. 11C})$$

Where:

$$\tau_2 \equiv 0.7\theta_{JC} \left(\frac{0.5C_P + C_S}{C_P + C_S} \right) 0.5C_P$$

$$T_3 \equiv 0.6P\theta_{JC} \left(1 - e^{-\frac{t}{\tau_3}} \right) \quad (\text{EQ. 11D})$$

Where:

$$\tau_3 \equiv 0.6\theta_{JC} C_D$$

Thermal Shutdown Hysteresis

Figure 9 shows the HIP5600 thermal hysteresis curve with $V_{IN} = 100V_{DC}$, $V_{OUT} = 5V$ and $I_{OUT} = 10mA$. Hysteresis is added to the thermal shutdown circuit to prevent oscillations as the junction temperature approaches the thermal shutdown limit. The thermal shutdown is reset when the input voltage is removed, goes negative (i.e. AC operation) or when the part cools down.

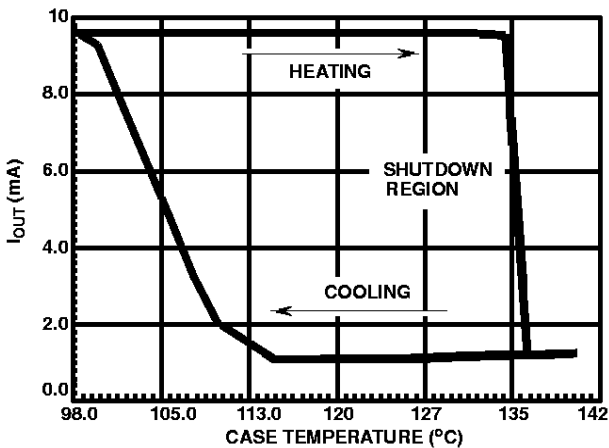

FIGURE 9. THERMAL HYSTERESIS CURVE

AC to DC Operation

Since the HIP5600 has internal high voltage diodes in series with its input, it can be connected directly to an AC power line. This is an improvement over typical low current supplies constructed from a high voltage diode and voltage dropping resistor to bias a low voltage zener. The HIP5600 provides better line and load regulation, better efficiency and heat transfer. The latter because the TO-220 package permits easy heat sinking.

The efficiency of either supply is approximately the DC output voltage divided by the RMS input voltage. The resistor value, in the typical low current supply, is chosen such that for maximum load at minimum line voltage there is some current flowing into the zener. This resistor value results in excess power dissipation for lighter loads or higher line voltages.

Using the circuit in Figure 3 with a 1000μF output capacitor the HIP5600 only takes as much current from the power line as the load requires. For light loads, the HIP5600 is even more efficient due to its interaction with the output capacitor. Immediately after the AC line goes positive, the HIP5600 tries to replace all the charge drained by the load during the negative half cycle at a rate limited by the short circuit current limit (see "A1" and "B1" Figure 10). Since most of this charge is replaced before the input voltage reaches its RMS value, the power dissipation for this charge is lower than it would be if the charge were transferred at a uniform rate during the cycle. When the product of the input voltage and current is averaged over a cycle, the average power is less than if the input current were constant. Figure 11 shows the HIP5600 efficiency as a function of load current for 80V_{RMS} and 132V_{RMS} inputs for a 15.6V output.

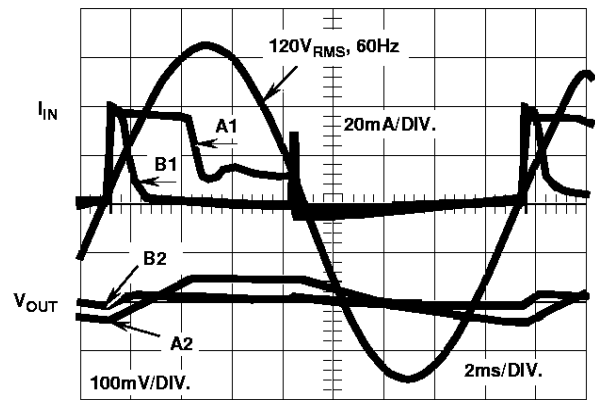

FIGURE 10. AC OPERATION

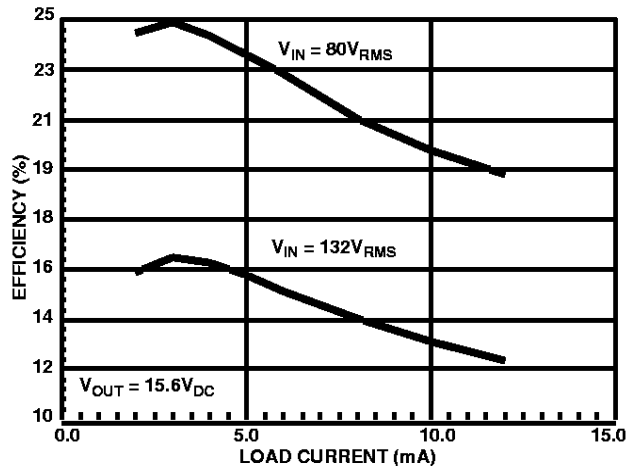

FIGURE 11. EFFICIENCY AS A FUNCTION OF LOAD CURRENT

Referring again to Figure 10, Curve "A1" shows the input current for a 10mA output load and curve "B1" with a 3mA output load. The input current spike just before the negative

HIP5600

going zero crossing occurs while the input voltage is less than the minimum operating voltage but is so short it has no detrimental effect. The input current also includes the charging current for the 0.02 μ F input decoupling capacitor C1.

The maximum load current cannot be greater than 1/2 of the short circuit current because the HIP5600 only conducts over 1/2 of the line cycle. The short circuit current limit (Figure 38) depends on the case temperature, which is a function of the power dissipation. Figure 38 for a case temperature of +100°C (i.e. no heat sink) indicates for AC operation the maximum available output current is 10mA (1/2 x 20mA). Operation from full wave rectified input will increase the maximum output current to 20mA for the same +100°C case temperature.

As a reminder, since the HIP5600 is off during the negative half cycle, the output capacitor must be large enough to supply the maximum load current during this time with some acceptable level of droop. Figure 10 also shows the output ripple voltage, for both a 10mA and 3mA output loads "A2" and "B2", respectively.

Do's And Don'ts

DC Operation

1. Do not exceed the absolute maximum ratings.
2. The HIP5600 requires a minimum output current of 1mA. Minimum output current includes current through RF1. **Warning:** If there is less than 1mA load current, the output voltage will rise. If the possibility of no load exists, RF1 should be sized to sink 1mA under these conditions.

$$RF1_{MIN} = \frac{V_{REF}}{1mA} = \frac{1.07V}{1mA} = 1k\Omega$$

3. Do not "HOT" switch the input voltage without protecting the input voltage from exceeding $\pm 650V$. Note: inductance from supplies and wires along with the 0.02 μ F decoupling capacitor can form an under damped tank circuit that could result in voltages which exceed the maximum $\pm 650V$ input voltage rating. Switch arcing can further aggravate the effects of the source inductance creating an over voltage condition.

Recommendation: Adequate protection means (such as MOV, avalanche diode, surge protector, etc.) may be needed to clamp transients to within the $\pm 650V$ input limit of the HIP5600.

4. Do not operate the part with the input voltage below the minimum 50V_{DC} recommended. **Low voltage operation:** For input voltages between 0V_{DC} and +5V_{DC} nothing happens ($I_{OUT}=0$), for input voltages between +5V_{DC} and +35V_{DC} there is not enough voltage for the pass transistor to operate properly and therefore a high frequency (2MHz) oscillation occurs. For input voltages +35V_{DC} to +50V_{DC} proper operation can occur with some parts.
5. **Warning:** the output voltage will approach the input voltage if the adjust pin is disconnected, resulting in permanent damage to the low voltage output capacitor.

AC Operation

1. Do not exceed the absolute maximum ratings.
2. The HIP5600 requires a minimum output current of 0.5mA. Minimum output current includes current through RF1. **Warning:** If there is less than 0.5mA output current, the output voltage will rise. If the possibility of no load exists, RF1 should be sized to sink 0.5mA under these conditions.

$$RF1_{MIN} = \frac{V_{REF}}{0.5mA} = \frac{1.07V}{0.5mA} = 2k\Omega$$

3. If using a laboratory AC source (such as VARIACs or step-up transformers, etc.) be aware that they contain large inductances that can generate damaging high voltage transients when they are switched on or off.

Recommendations

- (1) Preset VARIAC output voltage before applying power to part.
- (2) Adequate protection means (such as MOV, avalanche diode, surge protector, etc.) may be needed to clamp transients to within the $\pm 650V$ input limit of the HIP5600.
4. Do not operate the part with the input voltage below the minimum 50V_{RMS} recommended. **Low voltage operation similar to DC operation** (reference step 4 under DC operation).
5. **Warning:** the output voltage will approach the input voltage if the adjust pin is disconnected, resulting in permanent damage to the low voltage output capacitor.

General Precautions

Instrumentation Effects

Background: Input to output parasitic impedances exist in most test equipment power supplies. The inter-winding capacitance of the transformer may result in substantial current flow (mA) from the equipment power lines to the DC ground of the HIP5600. This "ground loop" current can result in erroneous measurements of the circuits performance and in some cases lead to overstress of the HIP5600.

Recommendations for Evaluation of the HIP5600 in the Lab

- a) The use of battery powered DVMs and scopes will eliminate ground loops.
- b) When connecting test equipment, locate grounds as close to circuit ground as possible.
- c) Input current measurements should be made with a non-contact current probe.

If AC powered test equipment is used, then the use of an isolated plug is recommended. The isolated plug eliminates any voltage difference between earth ground and AC ground. However, even though the earth ground is disconnected, ground loop currents can still flow through transformer of the test equipment. Ground loops can be **minimized** by connecting the test equipment ground as close to the circuit ground as possible.

CAUTION: Dangerous voltages may appear on exposed metal surfaces of AC powered test equipment.

Application Circuits

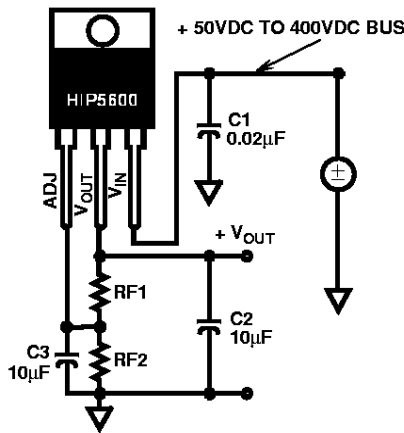

FIGURE 12. DC/DC CONVERTER

The HIP5600 can be configured in most common DC linear regulator applications circuits with an input voltage between 50V_{DC} to 400V_{DC} (above the output voltage) see Figure 12.

A 10µF capacitor (C2) provides stabilization of the output stage. Heat sinking may be required depending upon the power dissipation. Normally, choose $RF1 \ll V_{REF}/I_{ADJ}$.

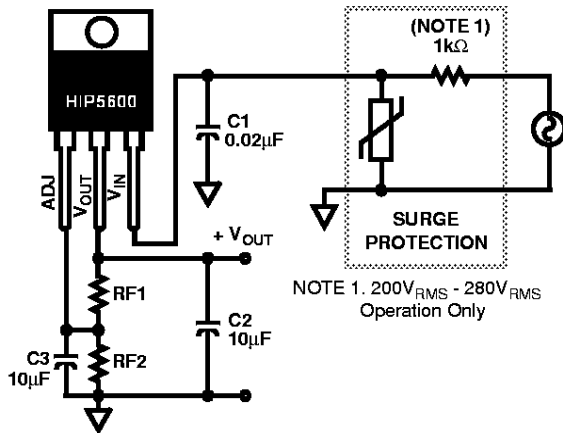

FIGURE 13. AC/DC CONVERTER

The HIP5600 can operate from an AC voltage between 50V_{RMS} to 280V_{RMS}, see Figure 13. The combination of a 1kΩ (2W) input resistor and a V275LA10B MOV provides input surge protection up to 6kV 1.2 x 50µs oscillating and pulse waveforms as defined in IEEE/ANSI C62.41.1980. When operating from 120V_{AC}, a V130LA10B MOV provides protection **without** the 1kΩ resistor.

The output capacitor is larger for operation from AC than DC because the HIP5600 only conducts current during the positive half cycle of the AC line. The efficiency is approximately equal to V_{OUT}/V_{IN} (RMS), see Figure 11.

The HIP5600 provides an efficient and economical solution as a start-up supply for applications operating from either AC (50V_{RMS} to 280V_{RMS}) or DC (50V_{DC} to 400V_{DC}).

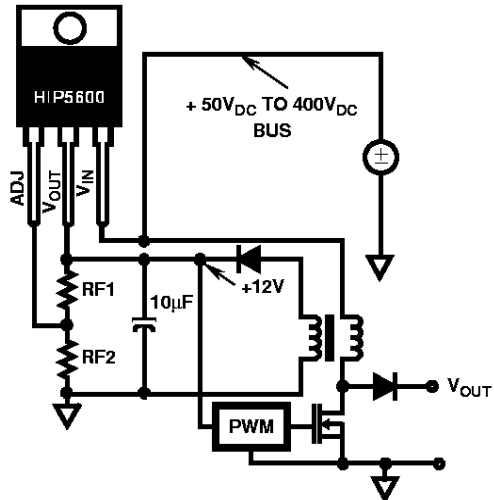

FIGURE 14. START UP CIRCUIT

The HIP5600 has on chip thermal protection and output current limiting circuitry. These features eliminate the need for an in-line fuse and a large heat sink.

The HIP5600 can provide up to 40mA for short periods of time to enable start up of a switch mode power supply's control circuit. The length of time that the HIP5600 will be on, prior to thermal shutdown, is a function of the power dissipation in the part, the amount of heat sinking (if any) and the ambient temperature. For example; at 400V_{DC} with no heat sink, it will provide 20mA for about 8s, see Figure 8.

Power supply efficiency is improved by turning off the HIP5600 when the SMPS is up and running. In this application the output of the HIP5600 would be set via RF1 and RF2 to be about 9V. The tickler winding would be adjusted to about 12V to insure that the HIP5600 is kept off during normal operating conditions. The input current under these conditions is approximately equal to I_{BIAS} . (See Figure 27).

The HIP5600 can supply a 450µA (±20%) constant current. (See Figure 15). It makes use of the internal bias network. See Figure 27 for bias current versus input voltage.

With the addition of a potentiometer and a 10µF capacitor the HIP5600 will provide a constant current source. I_{OUT} is given by Equation 13 in Figure 16.

The HIP5600 can control a P-channel MOSFET or IGPT in a self-oscillating buck regulator. The circuit shown (Figure 17) shows the self-oscillating concept with a P-IGBT driving a dedicated fan load. The output voltage is set by the resistor combination of RF1, RF2, and RF3. Components C3 and RF3 impresses the output ripple voltage across RF1 causing the HIP5600 to oscillate and control the conduction of the P-IGBT. The start-up protection components limit the initial surge current in the P-IGBT by forcing this device into its active region. The snubber circuit is recommended to reduce the power dissipation of the P-IGBT.

HIP5600

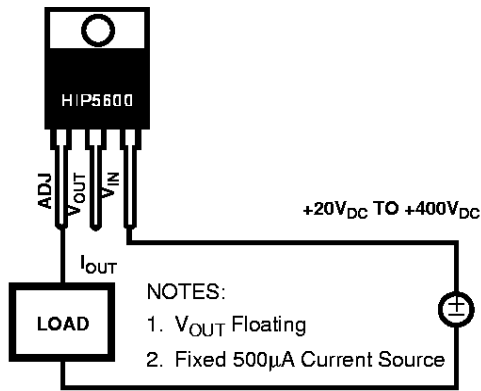

FIGURE 15. CONSTANT $450\mu\text{A}$ CURRENT SOURCE

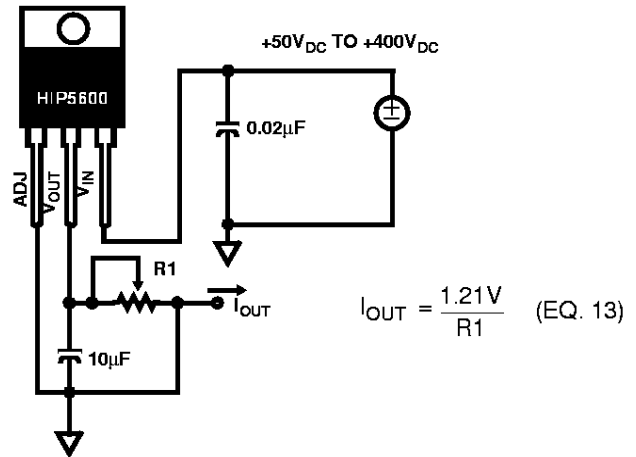

FIGURE 16. ADJUSTABLE CURRENT SOURCE

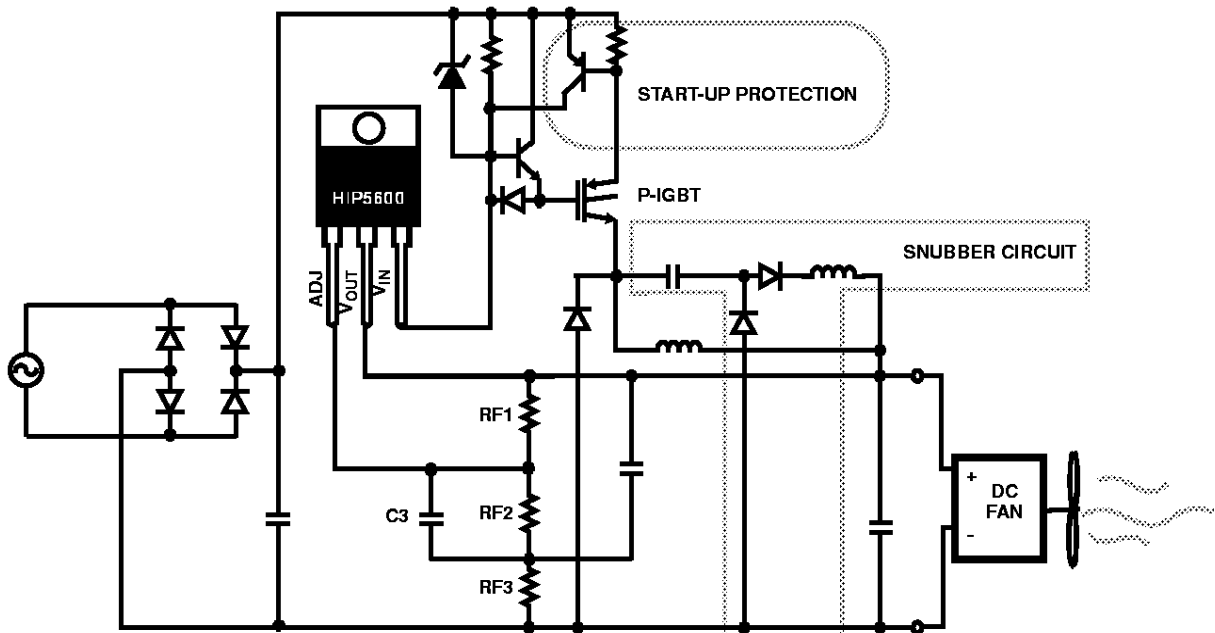

FIGURE 17. HIGH CURRENT "BUCK" REGULATOR CONCEPT

Typical Performance Curves

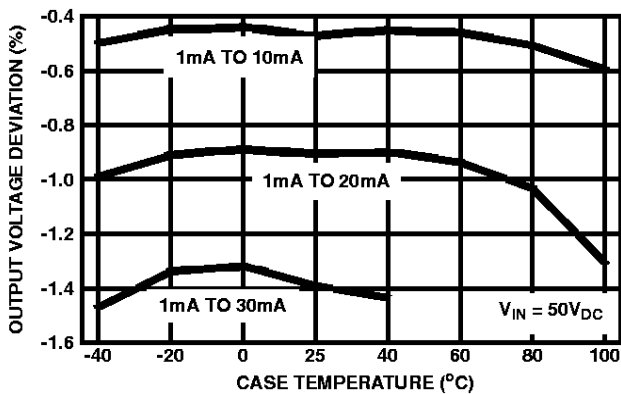

FIGURE 18. LOAD REGULATION vs TEMPERATURE

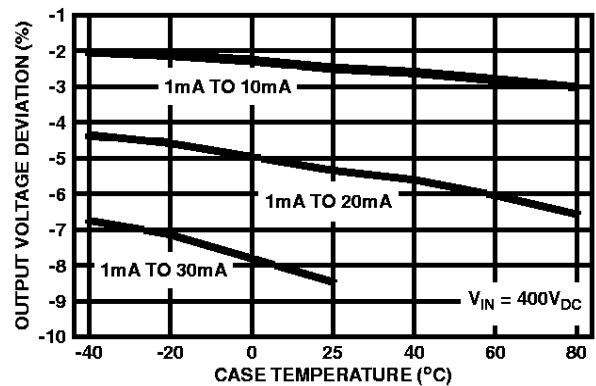

FIGURE 19. LOAD REGULATION vs TEMPERATURE

Typical Performance Curves (Continued)

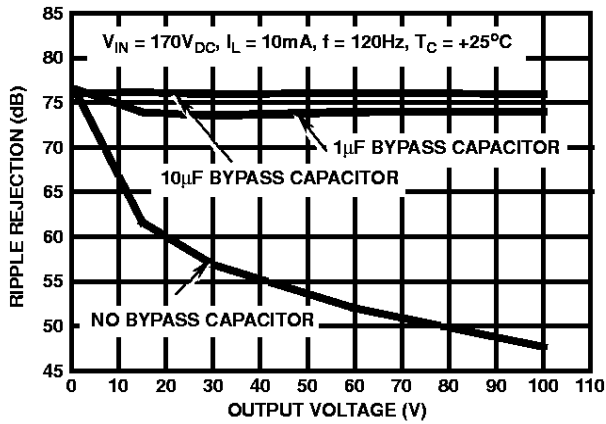

FIGURE 20. RIPPLE REJECTION RATIO (OUTPUT VOLTAGE)

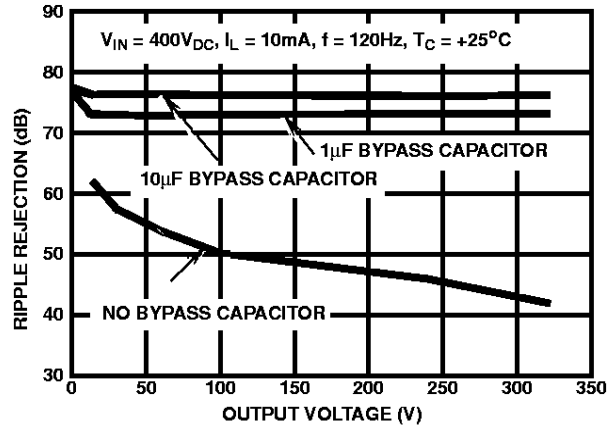

FIGURE 21. RIPPLE REJECTION RATIO (OUTPUT VOLTAGE)

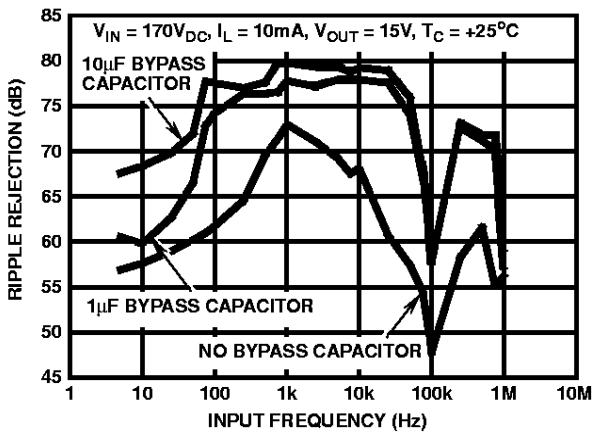

FIGURE 22. RIPPLE REJECTION RATIO (INPUT FREQUENCY)

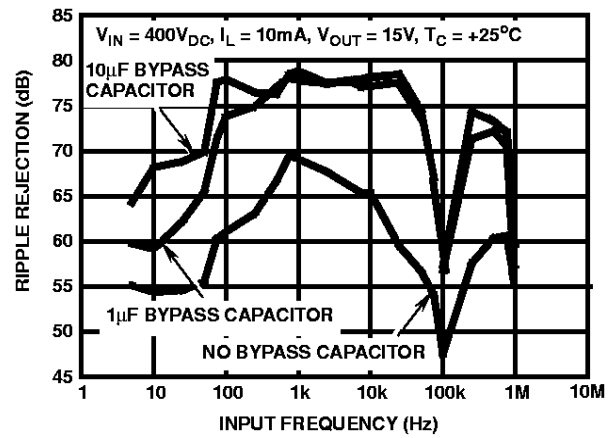

FIGURE 23. RIPPLE REJECTION RATIO (INPUT FREQUENCY)

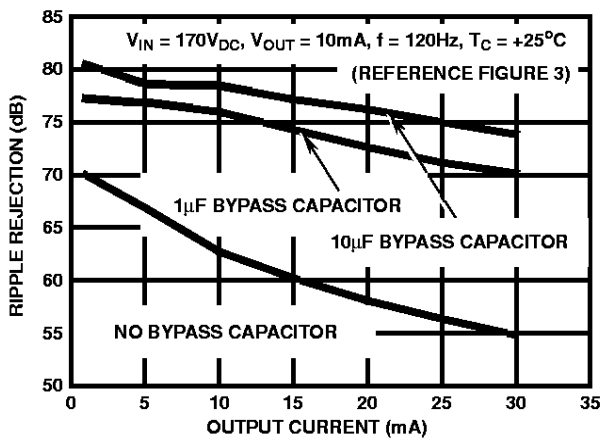

FIGURE 24. RIPPLE REJECTION RATIO (OUTPUT CURRENT)

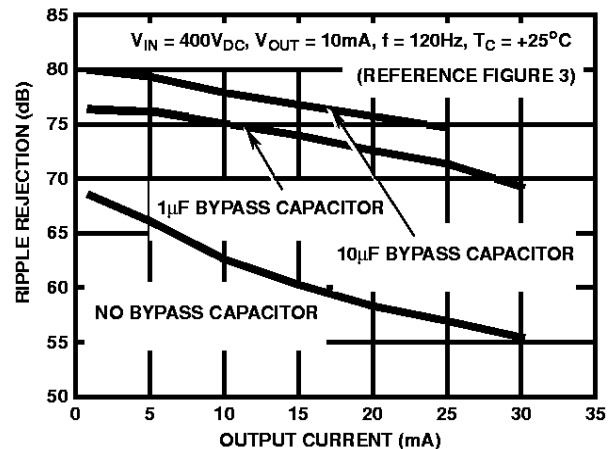

FIGURE 25. RIPPLE REJECTION RATIO (OUTPUT CURRENT)

Typical Performance Curves (Continued)

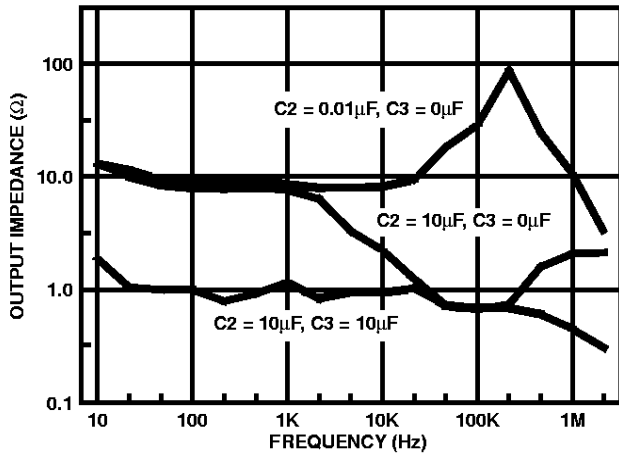

FIGURE 26. OUTPUT IMPEDANCE

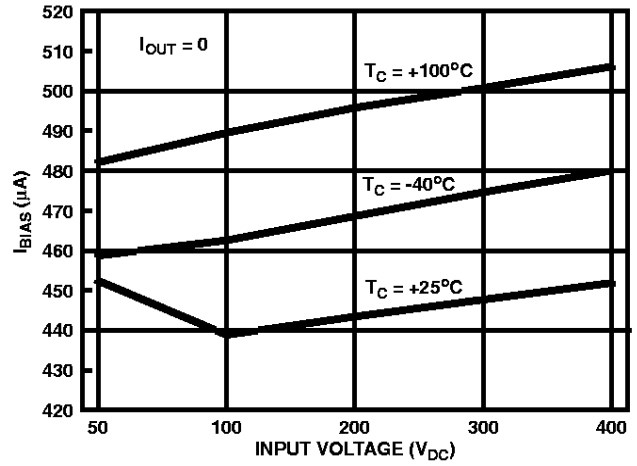

FIGURE 27. I_{BIAS} vs INPUT VOLTAGE

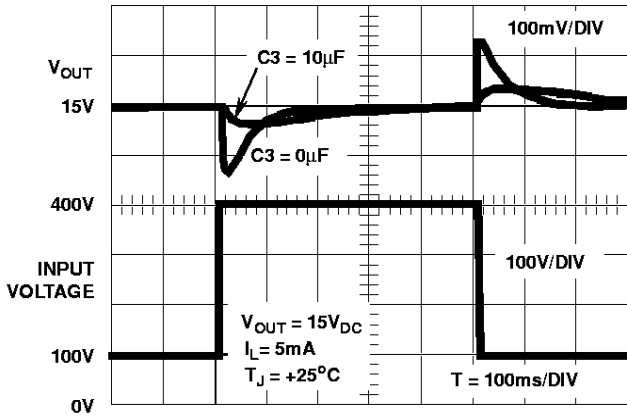

FIGURE 28. LINE TRANSIENT RESPONSE

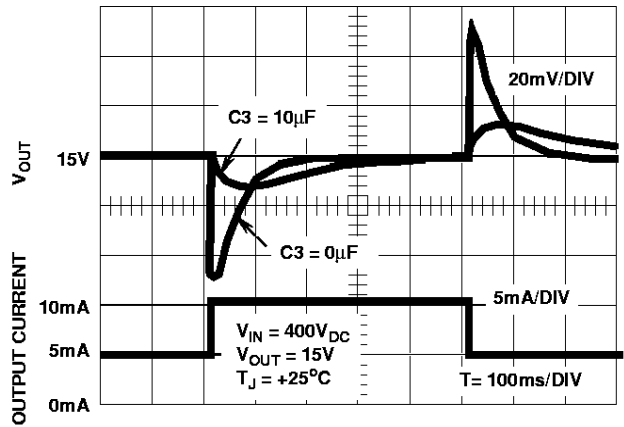

FIGURE 29. LOAD TRANSIENT RESPONSE

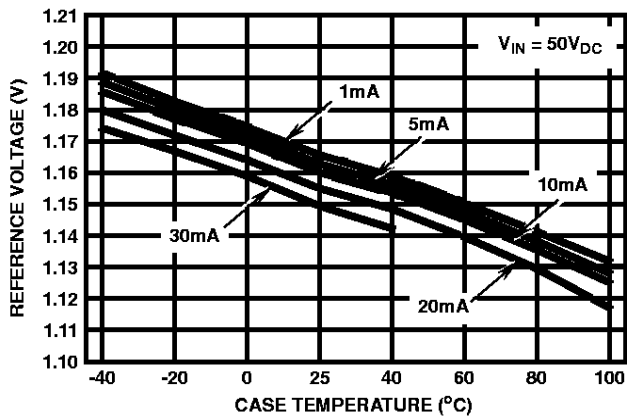

FIGURE 30. REFERENCE VOLTAGE vs TEMPERATURE

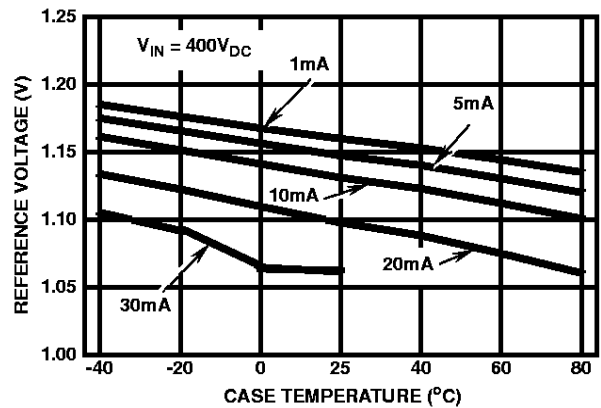

FIGURE 31. REFERENCE VOLTAGE vs TEMPERATURE

Typical Performance Curves (Continued)

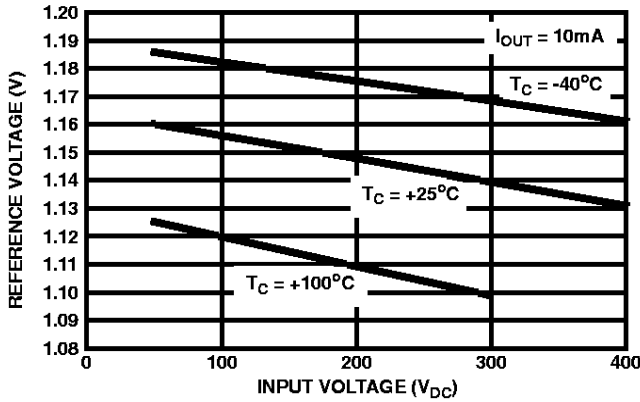

FIGURE 32. REFERENCE VOLTAGE vs INPUT VOLTAGE

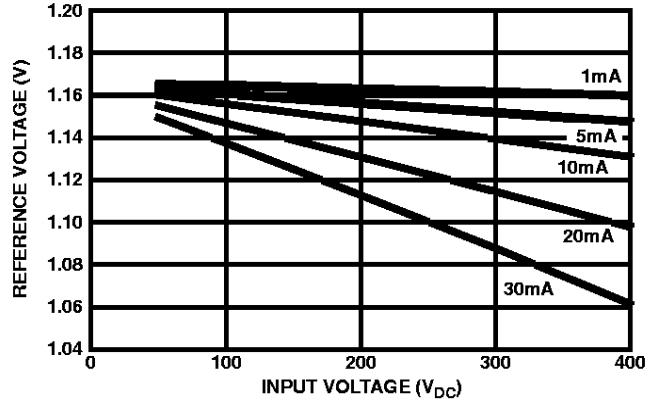

FIGURE 33. REFERENCE VOLTAGE vs V_{IN} ; CASE TEMPERATURE OF $+25^{\circ}\text{C}$

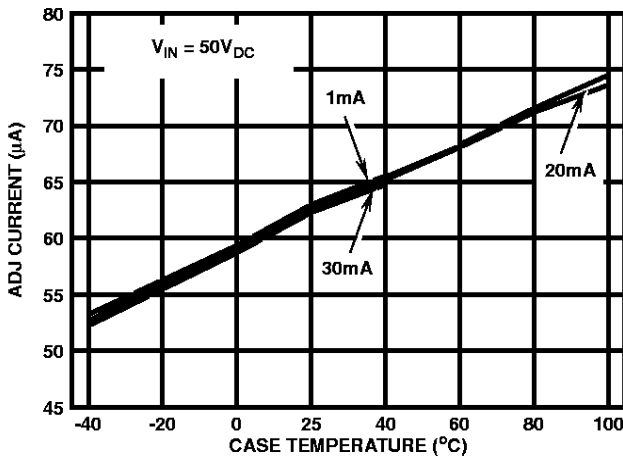

FIGURE 34. I_{ADJ} vs TEMPERATURE

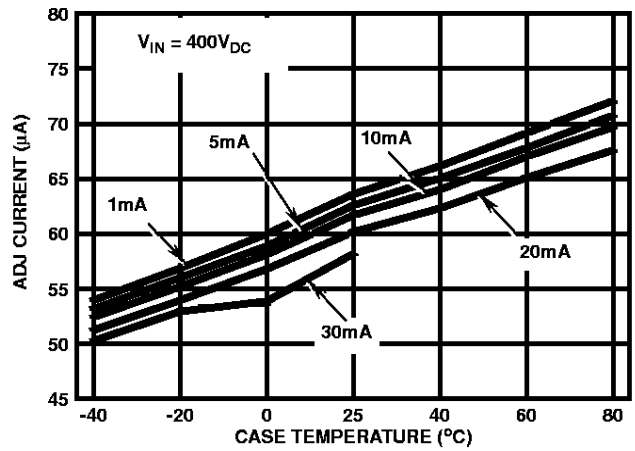

FIGURE 35. I_{ADJ} vs TEMPERATURE

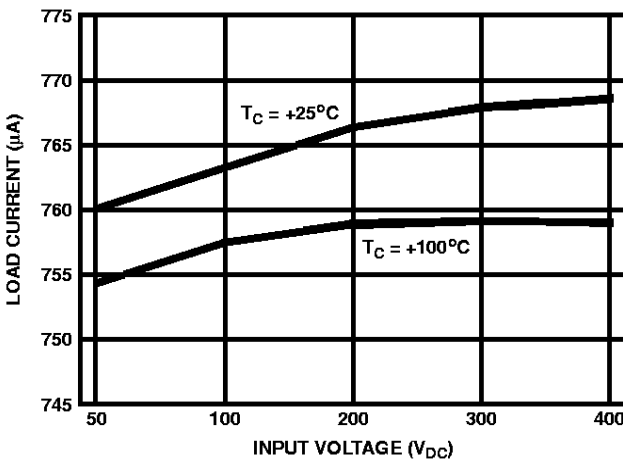

FIGURE 36. MINIMUM LOAD CURRENT vs V_{IN}

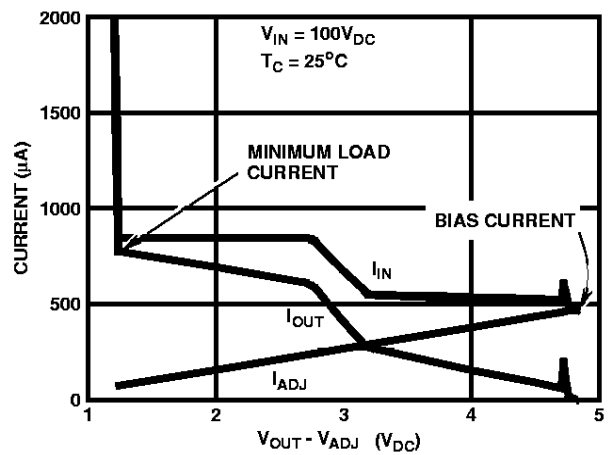

FIGURE 37. TERMINAL CURRENTS vs FORCED V_{REF}

Typical Performance Curves (Continued)

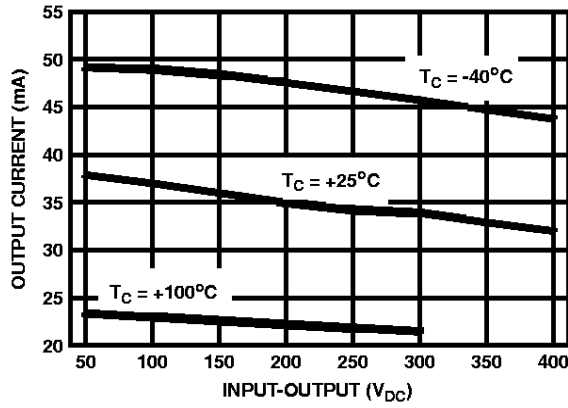

FIGURE 38. CURRENT LIMIT vs TEMPERATURE

Evaluation Boards

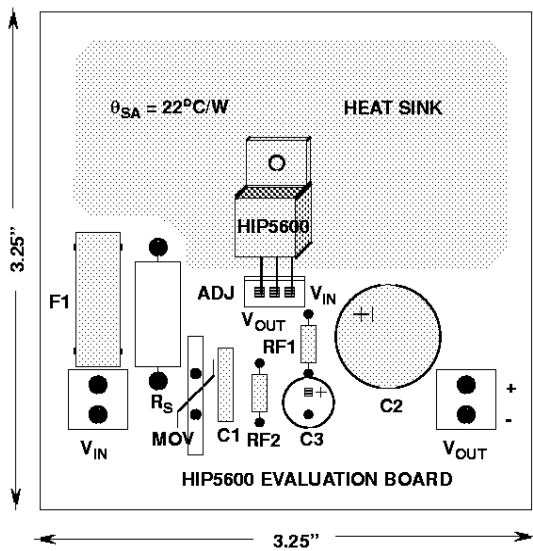

FIGURE 39. EVALUATION BOARD (TOP)

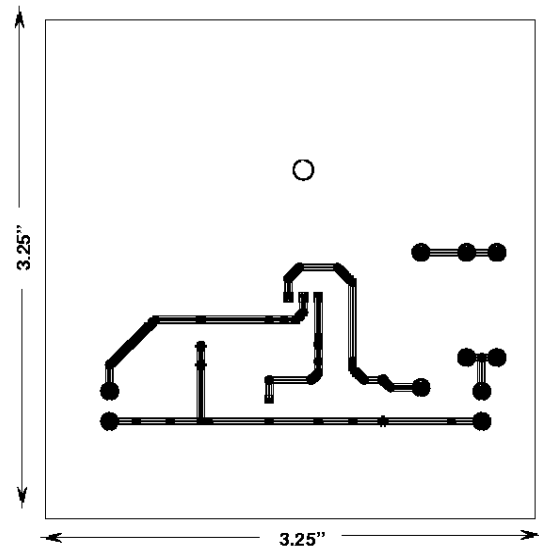

FIGURE 40. EVALUATION BOARD METAL MASK (BOTTOM)

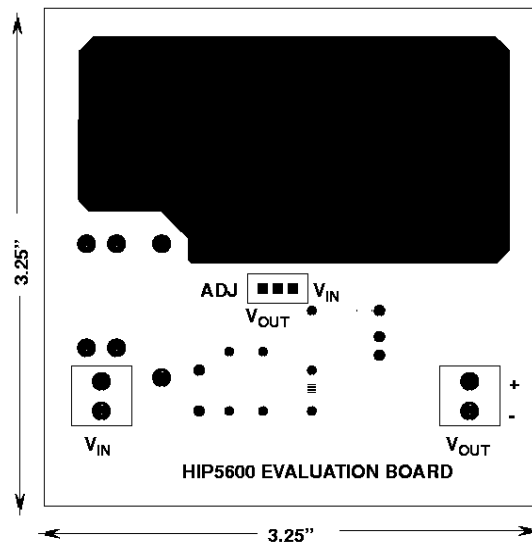
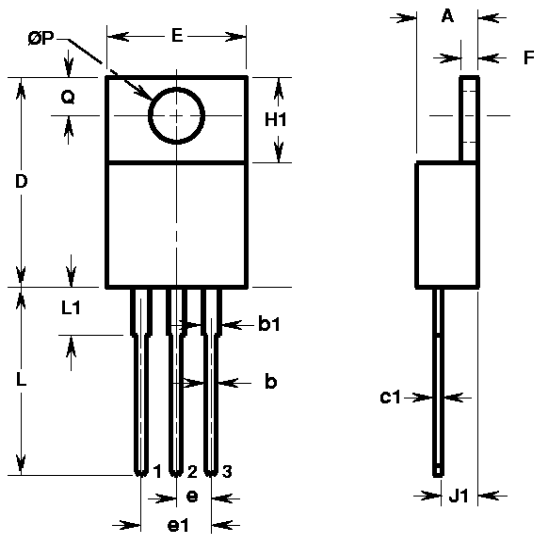

FIGURE 41. EVALUATION BOARD METAL MASK (TOP)

Single-In-Line Plastic Packages (SIP)



NOTES:

1. Lead dimension and finish uncontrolled in zone L1.
2. Position of lead to be measured 0.250 inches (6.35mm) from bottom of dimension D.
3. Position of lead to be measured 0.100 inches (2.54mm) from bottom of dimension D.
4. Controlling dimension: INCH.

Z3.1B
3 LEAD PLASTIC SINGLE-IN-LINE PACKAGE

SYMBOL	INCHES		MILLIMETERS		NOTES
	MIN	MAX	MIN	MAX	
A	0.140	0.190	3.56	4.82	-
b	0.015	0.040	0.38	1.02	-
b1	0.045	0.070	1.14	1.77	1
c1	0.014	0.022	0.36	0.56	1
D	0.560	0.650	14.23	16.51	-
E	0.380	0.420	9.66	10.66	-
e	0.090	0.110	2.29	2.79	2
e1	0.190	0.210	4.83	5.33	2
F	0.020	0.055	0.51	1.39	-
H1	0.230	0.270	5.85	6.85	-
J1	0.080	0.115	2.04	2.92	3
L	0.500	0.580	12.70	14.73	-
L1	-	0.250	-	6.35	1
$\varnothing P$	0.139	0.161	3.53	4.08	-
Q	0.100	0.135	2.54	3.43	-

Rev. 1 2/95

Single-In-Line Plastic Packages (SIP)

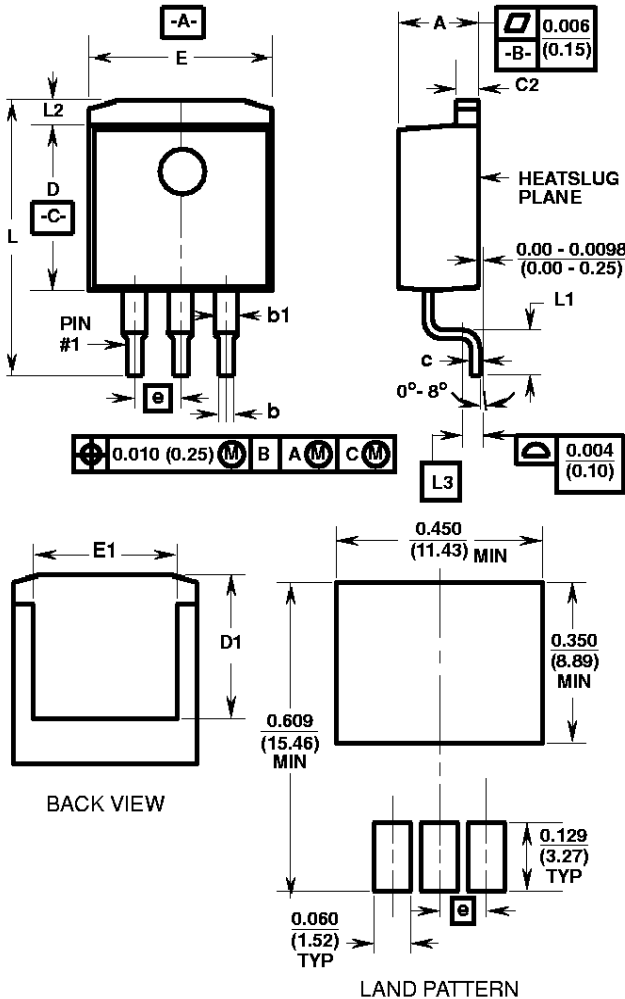

Z3.1D
3 LEAD PLASTIC SINGLE-IN-LINE PACKAGE SURFACE MOUNT
"GULLWING" LEAD FORM

SYMBOL	INCHES		MILLIMETERS		NOTES
	MIN	MAX	MIN	MAX	
A	0.170	0.180	4.32	4.57	-
C2	0.048	0.055	1.22	1.39	5
D	0.350	0.370	8.89	9.39	-
E	0.395	0.405	10.04	10.28	-
D1	0.310	-	7.88	-	-
E1	0.310	-	7.88	-	-
L	0.549	0.569	13.95	14.45	-
L1	0.068	0.088	1.72	2.24	-
L2	0.045	0.055	1.15	1.40	-
L3	0.030 BSC		0.76 BSC		4
b	0.030	0.037	0.77	0.94	5, 6
b1	0.045	0.054	1.15	1.37	5, 7
c	0.018	0.024	0.46	0.60	5
e	0.100 BSC		2.54 BSC		-

Rev. 1 12/95

NOTES:

1. These package dimensions are within allowable dimensions of JEDEC MO-169AA, Issue A.
2. Controlling dimension: Inch.
3. Dimensioning and tolerance per ANSI Y14.5M-1982.
4. Gauge plane L3 is parallel to heatslug plane.
5. Dimensions include lead finish.
6. Leads are not allowed above the datum -B-.
7. Dimension "b1" does not include dambar protrusion. Allowable dambar protrusion shall not cause the lead width to exceed the maximum "b1" by more than 0.003" (0.08mm).

All Harris Semiconductor products are manufactured, assembled and tested under ISO9000 quality systems certification.

Harris Semiconductor products are sold by description only. Harris Semiconductor reserves the right to make changes in circuit design and/or specifications at any time without notice. Accordingly, the reader is cautioned to verify that data sheets are current before placing orders. Information furnished by Harris is believed to be accurate and reliable. However, no responsibility is assumed by Harris or its subsidiaries for its use; nor for any infringements of patents or other rights of third parties which may result from its use. No license is granted by implication or otherwise under any patent or patent rights of Harris or its subsidiaries.

Sales Office Headquarters

For general information regarding Harris Semiconductor and its products, call 1-800-4-HARRIS

NORTH AMERICA
Harris Semiconductor
P. O. Box 883, Mail Stop 53-210
Melbourne, FL 32902
TEL: 1-800-442-7747
(407) 729-4984
FAX: (407) 729-5321

EUROPE
Harris Semiconductor
Mercure Center
100, Rue de la Fusee
1130 Brussels, Belgium
TEL: (32) 2.724.2111
FAX: (32) 2.724.22.05

ASIA
Harris Semiconductor PTE Ltd.
No. 1 Tannery Road
Cencon 1, #09-01
Singapore 1334
TEL: (65) 748-4200
FAX: (65) 748-0400

