

# THT POWER INDUCTORS

## Power Cube Inductors - PG0200NL Series



- Height:** 9.2mm Max
- Footprint:** 16.0mm x 13.2mm Max
- Current Rating:** up to 60Apk
- Inductance Range:** 0.21μH to 1.60μH

### Electrical Specifications @ 25°C — Operating Temperature -40°C to +125°C<sup>1</sup>

Part <sup>8</sup> Number	Inductance <sup>2</sup> @I <sub>rated</sub> (μH TYP)	I <sub>rated</sub> <sup>3</sup> (A)	DCR (mΩ)		Inductance @0Adc (μH ±15%)	Saturation <sup>4</sup> Current I <sub>SAT</sub> (A)	Heating <sup>5</sup> Current I <sub>DC</sub> (A)	Core Loss <sup>6</sup> Factor	
			TYP	MAX				(K1)	(K2)
PG0200.221NL	0.21	45	0.45	0.60	0.22	60+	45	5.12E-09	12.83
PG0200.351NL	0.32	45	0.45	0.60	0.35	55	45	5.12E-09	20.41
PG0200.451NL	0.43	29	1.10	1.45	0.45	50	29	5.12E-09	18.74
PG0200.601NL	0.57	29	1.10	1.45	0.60	45	29	5.12E-09	24.99
PG0200.801NL	0.76	23	2.10	2.40	0.80	44	23	5.12E-09	25.92
PG0200.102NL	0.88	23	2.10	2.40	1.0	35	23	5.12E-09	32.39
PG0200.132NL	1.23	19	2.55	3.00	1.3	34	19	5.12E-09	34.46
PG0200.152NL	1.42	19	2.55	3.00	1.5	25	19	5.12E-09	39.76
PG0200.182NL	1.60	19	2.55	3.00	1.8	20	19	5.12E-09	47.71

### Mechanical

### Schematic

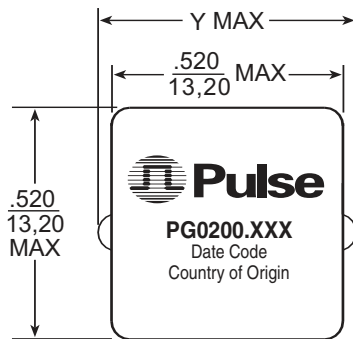

Part No.	X (in./mm)	Y (in./mm)	Z (in./mm)
PG0200.221	.492/12,50	.630/16,00	.087/2,20
PG0200.351	.492/12,50	.630/16,00	.087/2,20
PG0200.451	.500/12,70	.618/15,70	.063/1,60
PG0200.601	.500/12,70	.618/15,70	.063/1,60
PG0200.801	.394/10,00	.512/13,00	.051/1,30
PG0200.102	.394/10,00	.512/13,00	.051/1,30
PG0200.132	.433/11,00	.551/14,00	.051/1,30
PG0200.152	.433/11,00	.551/14,00	.051/1,30
PG0200.182	.433/11,00	.551/14,00	.051/1,30

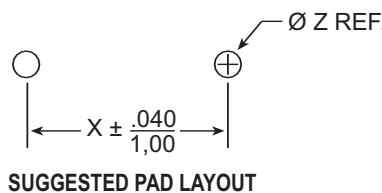
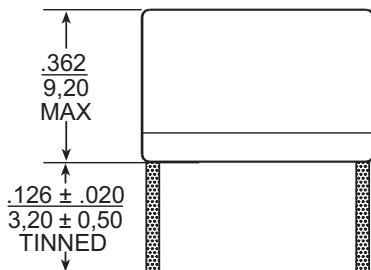
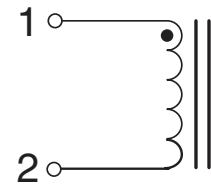

Weight .....7.2 grams  
Tray .....130/tray

Dimensions: Inches  
mm  
Unless otherwise specified,  
all tolerances are ± .010  
0,25

### Notes from Tables

1. The temperature of the component (ambient plus temperature rise) must be within the specified operating temperature range.
2. Inductance at  $I_{rated}$  is a typical inductance value for the component taken at rated current.
3. The rated current listed is the lower of the saturation current @ 25°C or the heating current.
4. The saturation current,  $I_{sat}$ , is the current at which the component inductance drops by 15% (typical) at an ambient temperature of 25°C. This current is determined by placing the component in the specified ambient environment and applying a short duration pulse current (to eliminate self-heating effects) to the component.
5. The heating current,  $I_{DC}$ , is the DC current required to raise the component temperature by approximately 40°C. The heating current is determined by mounting the component on a typical PCB and applying current for 30 minutes. The temperature is measured by placing the thermocouple on top of the unit under test. Take note that the component's performance varies depending on the system condition. It is suggested that the

component be tested at the system level, to verify the temperature rise of the component during system operation.

6. Core loss approximation is based on published core data:

$$\text{Core Loss} = K1 * (f)^{1.26} * (K2\Delta I)^{2.11}$$

Where: Core Loss = in Watts

$f$  = switching frequency in kHz

$K1$  &  $K2$  = core loss factors

$\Delta I$  = delta I across the component in Ampere

$K2\Delta I$  = one half of the peak to peak flux density across the component in Gauss

7. Unless otherwise specified, all testing is made at 100kHz, 0.1V<sub>AC</sub>.
8. The "NL" suffix indicates an RoHS-compliant part number. Non-NL suffixed parts are not necessarily RoHS compliant, but are electrically and mechanically equivalent to NL versions. If a part number does not have the "NL" suffix, but an RoHS compliant version is required, please contact Pulse for availability.

### Typical Inductance vs DC Bias Current Characteristics

