

7 6 5 4 3 2 1

SENSOR PROFILE

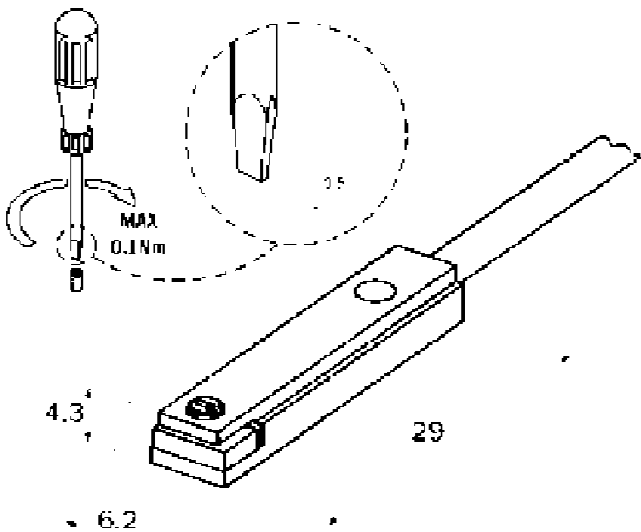
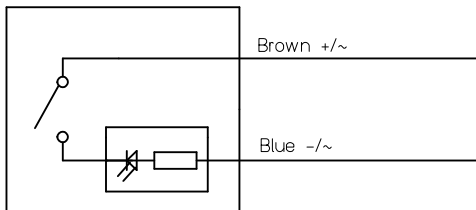
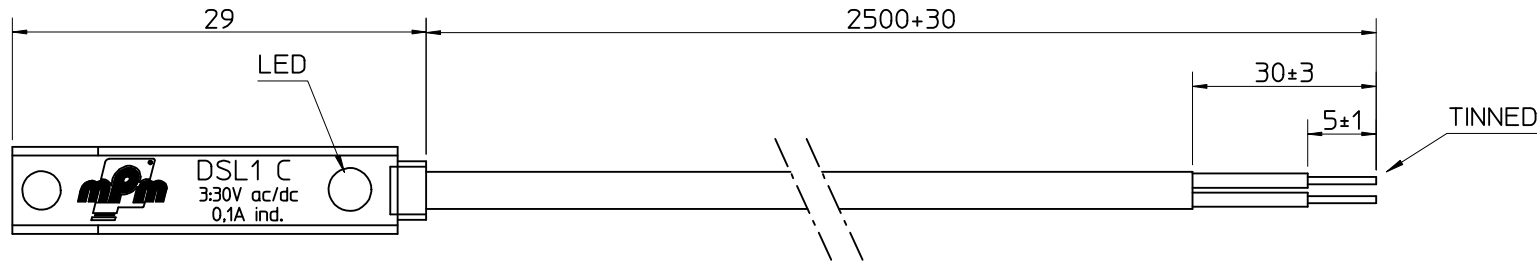
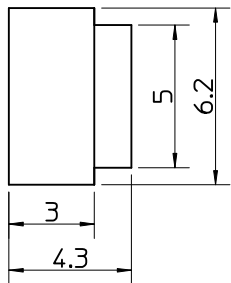

Engineering No.: DSL1C225

Technical data - Sensor	
Sensor type	2 wires REED normally Open
Cable	PVC CEI 20-22II OR 2x0.14mm ²
Temp. Range	-10...+70°C
Protecting Class	IP 67
Housing	PA, AISI 303, OT63
Voltage	3÷30 Vac/dc
Power rating (ohmic load)	6 W
Nominal operate point	20±25 AT
ON-OFF differential	5±10 AT
ON response time	0.5 ms
OFF response time	0.1 ms

Notes:
1. Sensor provided in plastic bag.

ORIGINAL RELEASE EC NO: IPG2016-0461 DRWN: JMARSZALEK 2014/02/28 CHKD: APPR: MIWASIECZKO 2015/09/28	DESCRIPTION A	QUALITY SYMBOLS	GENERAL TOLERANCES (UNLESS SPECIFIED)	DIMENSION STYLE MM ONLY	SCALE -	DESIGN UNITS METRIC	THIRD ANGLE PROJECTION																			
		▼=0 ▽=0	<table border="1"> <thead> <tr> <th></th> <th>mm</th> <th>INCH</th> </tr> </thead> <tbody> <tr> <td>4 PLACES</td> <td>±----</td> <td>±----</td> </tr> <tr> <td>3 PLACES</td> <td>±----</td> <td>±----</td> </tr> <tr> <td>2 PLACES</td> <td>±----</td> <td>±----</td> </tr> <tr> <td>1 PLACE</td> <td>±----</td> <td>±----</td> </tr> <tr> <td>0 PLACE</td> <td>±----</td> <td>±----</td> </tr> </tbody> </table>		mm	INCH	4 PLACES	±----	±----	3 PLACES	±----	±----	2 PLACES	±----	±----	1 PLACE	±----	±----	0 PLACE	±----	±----	DRAWN BY JMARSZALEK	DATE 2014/02/28	TITLE SENS SL1 REED/LED NO		
			mm	INCH																						
		4 PLACES	±----	±----																						
		3 PLACES	±----	±----																						
2 PLACES	±----	±----																								
1 PLACE	±----	±----																								
0 PLACE	±----	±----																								
	CHECKED BY DATE	APPROVED BY MIWASIECZKO	DATE 2015/09/28																							
	ANGULAR ±----° DRAFT WHERE APPLICABLE MUST REMAIN WITHIN DIMENSIONS	MATERIAL NO. 1211450015	DOCUMENT NO. SD-121145-001	SHEET NO. 1 OF 1																						
		SIZE A4	THIS DRAWING CONTAINS INFORMATION THAT IS PROPRIETARY TO MOLEX INCORPORATED AND SHOULD NOT BE USED WITHOUT WRITTEN PERMISSION																							

6 5 4 3 2 1

7 6 5 4 3 2 1

SENSOR PROFILE

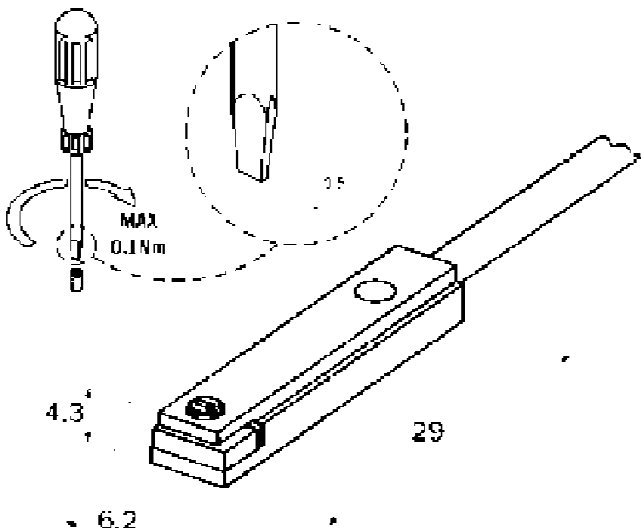
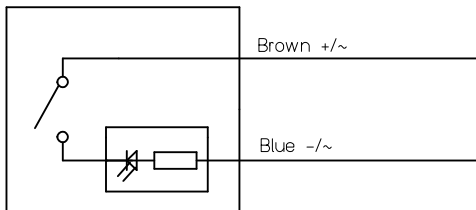
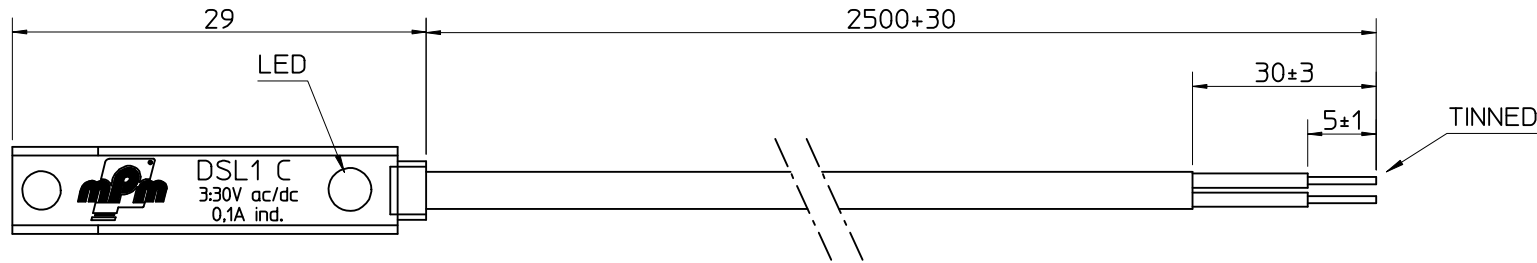
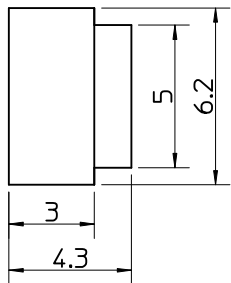

Engineering No.: DSL1C225

Technical data - Sensor	
Sensor type	2 wires REED normally Open
Cable	PVC CEI 20-22II OR 2x0.14mm ²
Temp. Range	-10...+70°C
Protecting Class	IP 67
Housing	PA, AISI 303, OT63
Voltage	3÷30 Vac/dc
Power rating (ohmic load)	6 W
Nominal operate point	20±25 AT
ON-OFF differential	5±10 AT
ON response time	0.5 ms
OFF response time	0.1 ms

ORIGINAL RELEASE EC NO: IPG2016-0461 DRWN: JMARSZALEK 2014/02/28 CHKD: APPR: MIWASIECZKO 2015/09/28	QUALITY SYMBOLS ▽=0 ▽=0	GENERAL TOLERANCES (UNLESS SPECIFIED)		DIMENSION STYLE	SCALE	DESIGN UNITS	THIRD ANGLE PROJECTION	
				MM ONLY	-	METRIC		
				DRAWN BY	DATE	TITLE		
				JMARSZALEK	2014/02/28	SENS SL1 REED/LED NO		
				CHECKED BY	DATE			
		APPROVED BY		DATE	molex			
		MIWASIECZKO		2015/09/28				
		MATERIAL NO.		DOCUMENT NO.	SHEET NO.			
		1211450015		SD-121145-001	1 OF 1			
		DRAFT WHERE APPLICABLE MUST REMAIN WITHIN DIMENSIONS		THIS DRAWING CONTAINS INFORMATION THAT IS PROPRIETARY TO MOLEX INCORPORATED AND SHOULD NOT BE USED WITHOUT WRITTEN PERMISSION				

Notes:
1. Sensor provided in plastic bag.

6 5 4 3 2 1