

REVISIONS			
REV	ECN, ERN NO.	DATE	APPRD.
A	PRODUCT DRAWING (EAR 12825)	SEP15/05	K.L.

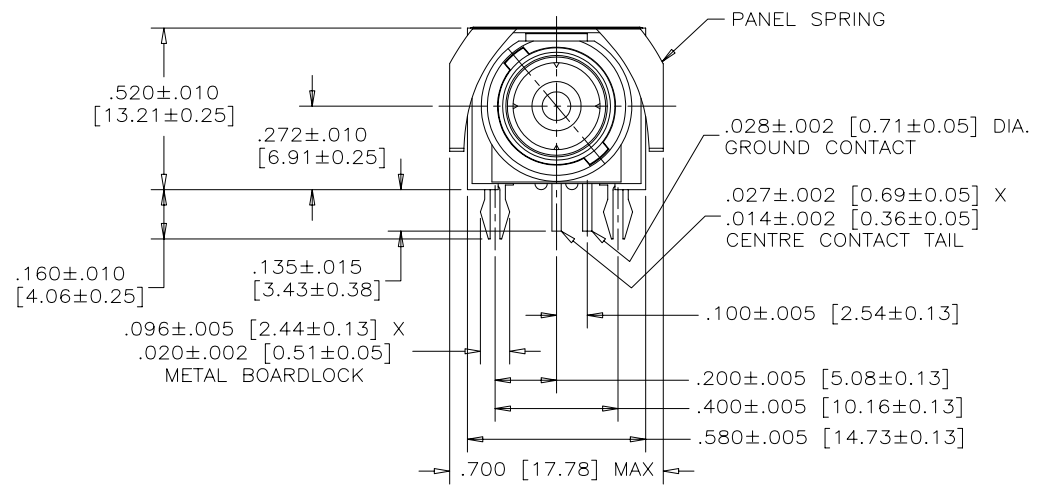
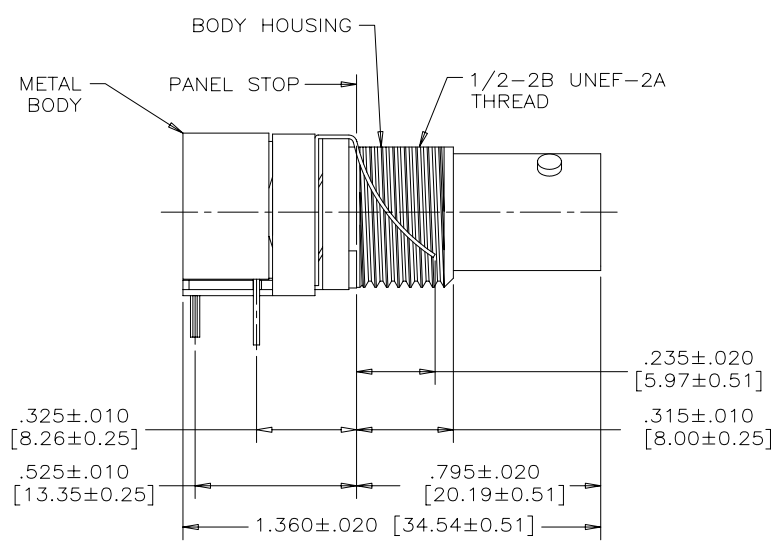

**MECHANICAL SPECIFICATION:**

ALL MATERIALS ARE RoHS COMPLIANT

BODY HOUSING: THERMOPLASTIC POLYESTER

GROUNDING DEVICE: COPPER ALLOY, TIN PLATED

CENTRE CONTACT: PHOSPHOR BRONZE, 10 MICROINCHES [0.25 MICRONS] GOLD PLATED OVER NICKEL

METAL BODY: HIGH STRENGTH ZINC DIE-CAST NICKEL PLATED

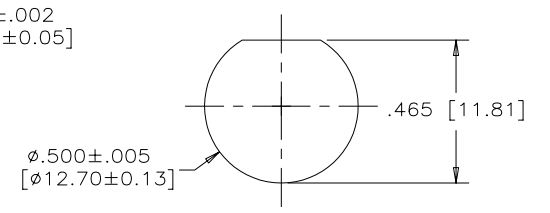
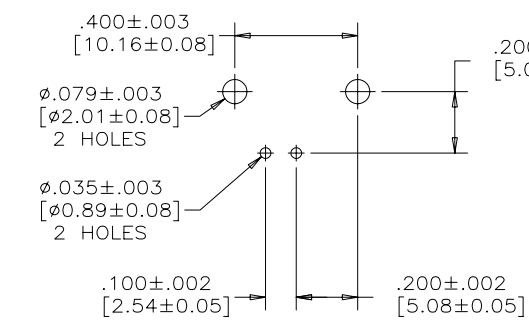

**ELECTRICAL SPECIFICATION:**

CAPACITANCE	10000 pF ± 15%
DIELECTRIC WITHSTANDING VOLTAGE	1000 VDC BREAK BY SPARK GAP DEVICE
WORKING VOLTAGE	200 VDC
IMPEDANCE (SEE PART NUMBER)	50 OR 75 OHM NOMINAL
OPERATING TEMPERATURE	-20°C TO +85°C

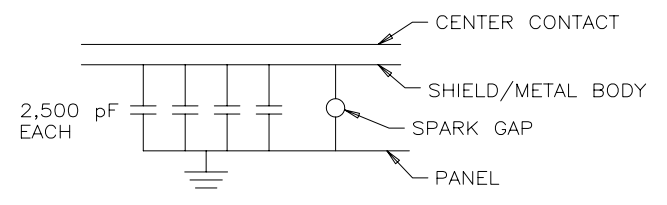

AMPHENOL PART NO.	IMPEDANCE
456E-117S	50 OHM
456E-717S	75 OHM

NOTE: BOARDLOCKS ARE ELECTRICALLY CONNECTED TO THE BODY.

NOTE: HOUSING MATERIALS NOT RECOMMENDED FOR HIGH TEMP REFLOW SOLDERING.

THIS DOCUMENT CONTAINS PROPRIETARY INFORMATION AND SUCH INFORMATION MAY NOT BE DISCLOSED TO OTHERS FOR ANY PURPOSE OR USED FOR MANUFACTURING PURPOSES WITHOUT WRITTEN PERMISSION FROM AMPHENOL CANADA CORP.

DRAWN K. LAMBIE	DATE SEP15/05
DESIGNED	
CHECKED	
I. E. APPRD.	
Q. A. APPRD.	
DWG. APPRD.	
ENG. REL. NO.	
REF. EAR 12825	
DIMENSIONS ARE IN INCHES [mm]	CODE ID. NO. 03554

**Amphenol Canada Corp.**

456E SERIES B.N.C. RIGHT ANGLE CAPACITIVELY DECOUPLED CONNECTOR (WITH SPARK GAP), RoHS COMPLIANT

DWG. C	DRAWING NO. P-456E-X17S	REV. A
--------	-------------------------	--------

SCALE 3/1 WT. ----- SURF. ----- SHEET 1 OF 1