

PRODUCT NUMBER
SEE TABLE

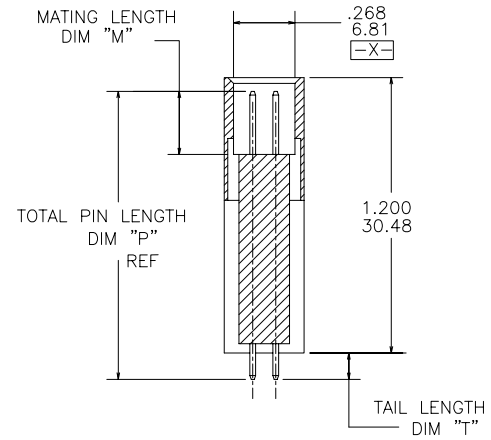

SECTION A-A

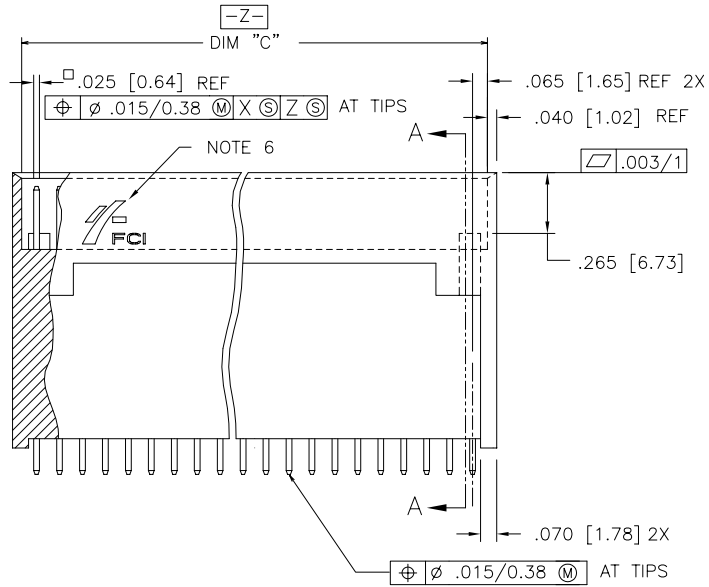
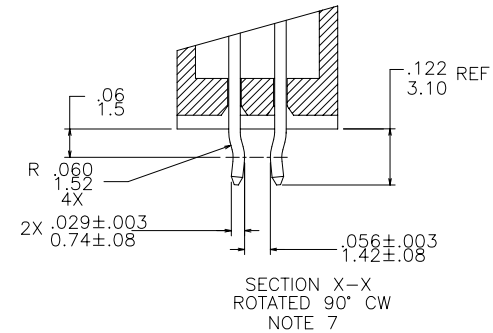
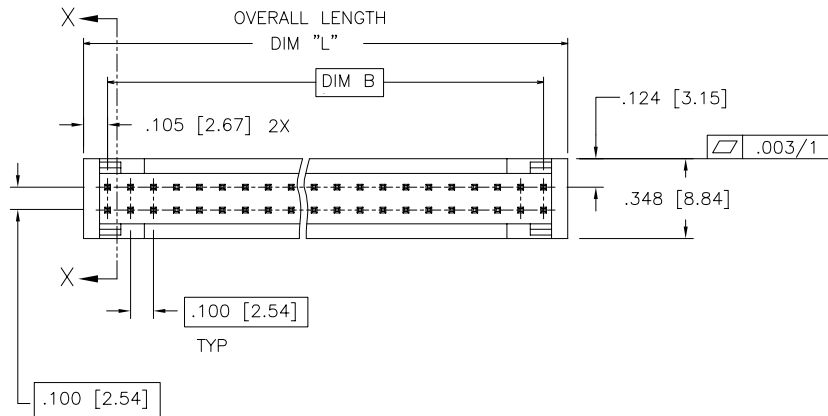

SECTION X-X
ROTATED 90° CW
NOTE 7

FCI
FCIconnect.com

Copyright FCI

mat'l. code				surface ISO 1302 ✓		tolerance ISO 406 ISO 1101		projection INCH/MM		product family HEADER			
tolerances unless otherwise specified				angles		linear		scale 1:1		title			
J	v50987	MDF	8/26/95	.XX±.01/.3		.XXX±.005/.13				VERTICAL STACKING 2-ROW HEADER			
K	v60356	MDF	4/24/96	0°±2'		.XXXX±.0020/.051				1.200/30.48 W/O MOUNTING HOLES			
L	v60834	LSS	8/1/96							dwg no 68205 sheet 1 of 4 size A3			
M	C70069	EPK	9/22/97	dr		M. FETROW 8/26/95				type Product Customer Drawing			
N	C10007	DAI	4/11/01	enrg		L. FYE 8/26/95							
P	M05-0089	MHT	5/19/05	chr		T. BREWBAKER 8/26/95							
R	M07-0116	AGS	2/19/07	appd		L. FYE 8/26/95							
sheet index	revision	R	R	R	R	R	R						
sheet index	sheet	1	2	3	4								

POSITION TABLE		
PRODUCT NO	SIZE	NOTES
XXXXX-001	UNAVAILABLE	
-002	UNAVAILABLE	
-003	UNAVAILABLE	
-004	UNAVAILABLE	
-005	UNAVAILABLE	
-006	2X10	NOTE 7
-007	UNAVAILABLE	
-008	UNAVAILABLE	
-009	UNAVAILABLE	
-010	UNAVAILABLE	
-011	2X15	
-012	UNAVAILABLE	
-013	UNAVAILABLE	
-014	UNAVAILABLE	
-015	UNAVAILABLE	
-016	2X20	
-017	UNAVAILABLE	
-018	UNAVAILABLE	
-019	UNAVAILABLE	
-020	2X24	
-021	UNAVAILABLE	
-022	2X26	
-023	UNAVAILABLE	
-024	UNAVAILABLE	
-025	UNAVAILABLE	
-026	2X30	
-027	UNAVAILABLE	
-028	2X32	
-029	UNAVAILABLE	
-030	UNAVAILABLE	
-031	UNAVAILABLE	
XXXXX-032	UNAVAILABLE	

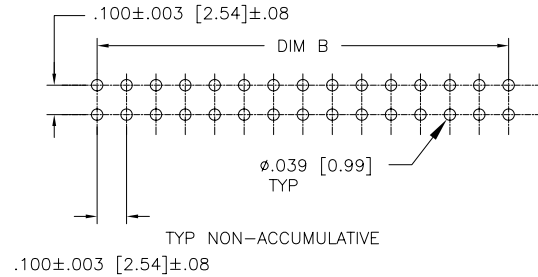
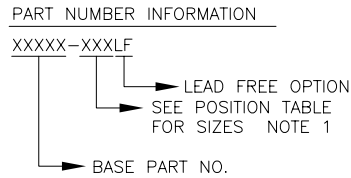

RECOMMENDED PC BOARD LAYOUT
SCALE 2/1

NOTES:

- SEE POSITION TABLE FOR PRODUCT NO AND SIZE TABULATION. HOUSING DASH NO IS SAME AS HEADER DASH NO.
- DIM B =
(NO OF COLUMNS - 1) TIMES .100 (ENGLISH)
(NO OF COLUMNS - 1) TIMES 2.54 (METRIC)
- MOLDING MATERIAL: 20% MIN GLASS FILLED NYLON PER UL 94V-0. COLOR: BLACK,
- TERMINAL MATERIAL: 3/4 HARD PHOS BRONZE ALLOY UNS C51000.
- PIN RETENTION TO BE 3 LBS./1.4 KGS MINIMUM PER PIN IN EITHER DIRECTION.
- COMPANY LOGO TO BE MOLDED IN APPROX LOCATION SHOWN.
- "R" AT THE END OF PART NUMBER WILL BE FOR RETENTION PINS (KINKED).
- ADD "LF" SUFFIX AT THE END OF PART NUMBER FOR LEAD FREE OPTION.
- THE HOUSING WILL WITHSTAND EXPOSURE TO 260°C PEAK TEMPERATURE FOR 15 SECONDS IN A WAVE SOLDER APPLICATION WITH A 1.5mm MINIMUM THICK CIRCUIT BOARD. SEE APPLICATION NOTES/PROCEDURES IF THEY ARE AVAILABLE.
- THESE PRODUCT MEETS EUROPEAN UNION DIRECTIVES AND OTHER COUNTRY REGULATION AS DESCRIBED IN GS-22-008.
- PLATING OPTIONS:
MAY BE EITHER GOLD OR GXT PLATED AT MANUFACTURER'S OPTION.

mat'l. code		surface ISO 1302 ✓	tolerance ISO 406 ISO 1101	projection ⊕	product family HEADER
ltr	ecn	no	dr	date	title
R					VERTICAL STACKING 2-ROW HEADER
tolerances unless otherwise specified		angles	linear	INCH/MM	1.200/30.48 W/O MOUNTING HOLES
		0°±2'	.XX±.01/.3 .XXX±.005/.13 .XXX±.0020/.051	scale 1:1	
dr	M. FETROW	8/26/95			dwg no
enr	L. FYE	8/26/95			sheet 2 of 4
chr	T. BREWBAKER	8/26/95			size A3
app	L. FYE	8/26/95			type Product Customer Drawing
sheet index	revision sheet				

FCI
 FCIconnect.com
 Copyright FCI

PRODUCT NO NOTE 8	TERMINAL PLATING (NOTE 11)
68205-XXX	15u"/0.38u MIN Au OVER 50u"/1.27u MIN Ni.
68585-XXX	30u"/0.76u MIN GXT OVER 50u"/1.27u MIN Ni.
68882-XXX	30u"/0.76u MIN Au OVER 50u"/1.27u MIN Ni.
69213-XXX	120u"/3.05u MIN TIN LEAD OVER 50u"/1.27u MIN Ni.
69215-XXX	15u"/0.38u MIN GXT OVER 50u"/1.27u MIN Ni.
69965-XXX	DUPLEX { CONTACT: 15u"/0.38u MIN Au OVER 50u"/1.27u Ni. TAIL: 100u"/2.54u MIN TIN OVER 50u"/1.27u Ni.
69969-XXX	DUPLEX { CONTACT: 30u"/0.76u MIN Au OVER 50u"/1.27u Ni. TAIL: 100u"/2.54u MIN TIN OVER 50u"/1.27u Ni.



FCIconnect.com

Copyright FCI

mat'l. code		surface ISO 1302 ✓	tolerance ISO 406 ISO 1101	projection 	product family HEADER
ltr	ecn no	dr	date	tolerances unless otherwise specified	title
R				angles .XX±.01/.3 linear .xxx±.005/.13 0°±2' .xxx±.0020/.051	VERTICAL STACKING 2-ROW HEADER
				scale 1:1	1.200/30.48 W/O MOUNTING HOLES
		dr	M. FETROW	8/26/95	dwg no
		enr	L. FYE	8/26/95	sheet 3 of 4
		chr	T. BREWBAKER	8/26/95	size
		app	L. FYE	8/26/95	A3
sheet index	revision sheet				type Product Customer Drawing



form: A3

PRODUCT NO NOTE 8	SIZE	DIM "B"	DIM "C"	DIM "L"	TAIL LENGTH DIM "T"	MATING LENGTH DIM "M"	TOTAL PIN LENGTH DIM "P"	NOTES
68205-XXX	NOTE 1	NOTE 2	DIM "B" +.130/3.30	DIM "B" +.210/5.33	.103/2.62 MIN .130/3.30 MAX	.275±.010 6.98±0.25	1.255/31.88	
68205-033	2 x 32	3.100/78.74	3.23/82.0	3.31/84.1	.145±.010 3.68±0.25	.275±.010 6.98±0.25	1.255/31.88	
68205-034	2 x 15	1.400/35.56	1.53/38.9	1.61/40.9	.148±.008 3.76±0.20	.275±.010 6.98±0.25	1.255/31.88	
68205-035	2 x 26	2.500/63.50	2.63/66.8	2.71/68.8	.148±.008 3.76±0.20	.275±.010 6.98±0.25	1.255/31.88	
68585-XXX	NOTE 1	NOTE 2	DIM "B" +.130/3.30	DIM "B" +.210/5.33	.120/3.05	.275±.010 6.98±0.25	1.255/31.88	NOTE 7
68882-XXX	NOTE 1	NOTE 2	DIM "B" +.130/3.30	DIM "B" +.210/5.33	.103/2.62 MIN .130/3.30 MAX	.275±.010 6.98±0.25	1.255/31.88	
69213-XXX	NOTE 1	NOTE 2	DIM "B" +.130/3.30	DIM "B" +.210/5.33	.103/2.62 MIN .130/3.30 MAX	.275±.010 6.98±0.25	1.255/31.88	
69215-XXX	NOTE 1	NOTE 2	DIM "B" +.130/3.30	DIM "B" +.210/5.33	.103/2.62 MIN .130/3.30 MAX	.275±.010 6.98±0.25	1.255/31.88	
69965-XXX	NOTE 1	NOTE 2	DIM "B" +.130/3.30	DIM "B" +.210/5.33	.103/2.62 MIN .130/3.30 MAX	.275±.010 6.98±0.25	1.255/31.88	
69969-XXX	NOTE 1	NOTE 2	DIM "B" +.130/3.30	DIM "B" +.210/5.33	.103/2.62 MIN .130/3.30 MAX	.275±.010 6.98±0.25	1.255/31.88	



Copyright FCI

mat'l. code		surface ISO 1302 ✓		tolerance ISO 406 ISO 1101		projection 		product family HEADER	
ltr	ecn	no	dr	date		tolerances unless otherwise specified		title	
R						angles	linear	.XX±.01/.3	VERTICAL STACKING 2-ROW HEADER
						0°±2'		.XXX±.005/.13	1.200/30.48 W/O MOUNTING HOLES
								.XXXX±.0020/.051	scale 1:1
						dr	M. FETROW	8/26/95	dwg no
						enr	L. FYE	8/26/95	sheet 4 of 4
						chr	T. BREWBAKER	8/26/95	size
						appd	L. FYE	8/26/95	A3
sheet index		revision sheet						type Product Customer Drawing	

