

PART NO.	SCREW SIZE	"L" ± .015 (± 0.38)	"A" ± .007 (± 0.18)	"B" ± .007 (± 0.18)	"C" ± .005 (± 0.13)	"D" ± .005 (± 0.13)	MATERIAL		
MNI #2-2	#2 (M2.2)	.031 (0.8)	.181 (4.6)	.047 (1.2)	.120 (3.0)	.090 (2.3)	RMS-48		
MNI #2-4		.063 (1.6)							
MNI #4-2	#4 (M3)	.031 (0.8)	.235 (6.0)		.145 (3.7)	.140 (3.6)	.115 (2.9)	RMS-01	
MNI #4-3		.046 (1.2)							
MNI #4-4		.063 (1.6)							
MNI #4-5		.084 (2.1)	.252 (6.4)						
MNI #4-6		.093 (2.4)	.235 (6.0)		.145 (3.7)	.140 (3.6)	.115 (2.9)	RMS-01	
MNI #4-8		.125 (3.2)							
MNI #4-10		.156 (4.0)							
MNI #4-12		.187 (4.8)							
MNI #4-16		.250 (6.4)							
MNI #4-24		.375 (9.5)							
MNI #5-3	#5 (M3)	.051 (1.3)	.370 (9.4)	.063 (1.6)	.236 (6.0)	.128 (3.3)	RMS-48		
MNI #6-2	#6 (M3.5)	.031 (0.8)	.290 (7.4)					.170 (4.3)	.140 (3.6)
MNI #6-4		.063 (1.6)							
MNI #6-6		.093 (2.4)							
MNI #6-8		.125 (3.2)							
MNI #6-12		.187 (4.7)							
MNI #6-16		.250 (6.4)							
MNI #6-24		.375 (9.5)							
MNI #6-32		.500 (12.7)							
MNI #8-2	#8 (M4)	.031 (0.8)	.344 (8.7)		.205 (5.2)	.173 (4.4)		.173 (4.4)	RMS-01
MNI #8-4		.063 (1.6)							
MNI #8-6		.093 (2.4)							
MNI #8-8		.125 (3.2)							
MNI #8-12		.187 (4.7)							
MNI #8-16		.250 (6.4)							
MNI #8-24	.375 (9.5)								
MNI #8-32	.500 (12.7)								
MNI #10-4	#10 (M5)	.063 (1.6)	.399 (10.1)	.260 (6.6)	.200 (5.1)	.200 (5.1)	RMS-01		
MNI #10-6		.093 (2.4)							
MNI #10-8		.125 (3.2)							
MNI #10-12		.187 (4.7)							
MNI #10-16		.250 (6.4)							
MNI #10-24		.375 (9.5)							
MNI #10-32	.500 (12.7)								
MNI 1/4-6	1/4 (M6)	.093 (2.4)	.513 (13.0)	.065 (1.7)	.312 (8.0)	.260 (6.6)	RMS-48		
MNI 1/4-12		.187 (4.7)							
MNI 1/4-16		.250 (6.4)							
MNI 1/4-24		.375 (9.5)							
MNI 1/4-32		.500 (12.7)							
MNI 5/16-6	5/16 (M8)	.093 (2.4)	.620 (15.7)	.063 (1.6)	.360 (9.1)	.320 (8.1)	RMS-48		
MNI 5/16-16		.250 (6.4)							
MNI M2.5-1.3	M2.5	.051 (1.3)	.248 (6.3)	.047 (1.2)	.138 (3.5)	.114 (2.9)	RMS-01		
MNI M2.5-3.6		.142 (3.6)		.059 (1.5)		.110 (2.8)			
MNI M3-1.0	M3	.039 (1.0)	.280 (7.1)	.039 (1.0)	.150 (3.8)	.122 (3.1)	RMS-48		
MNI M3-2.5		.098 (2.5)							
MNI M3-1.3		.051 (1.3)	.347 (8.8)	.047 (1.2)	.236 (6.0)	.126 (3.2)			
MNI M3-3.5		.137 (3.5)	.280 (7.1)	.039 (1.0)	.150 (3.8)	.122 (3.1)			

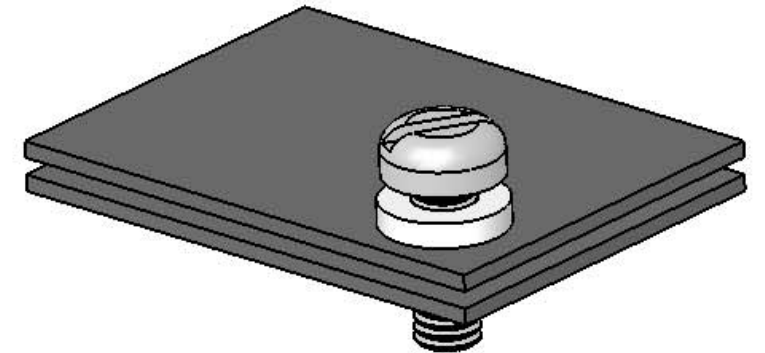
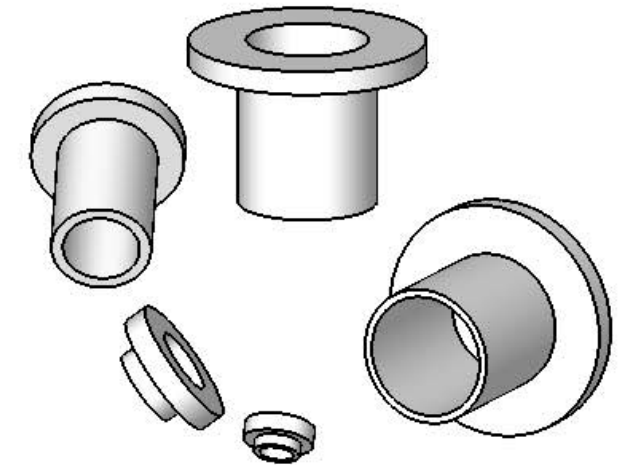
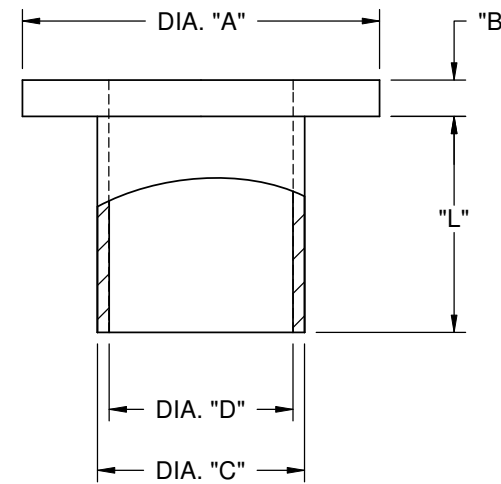
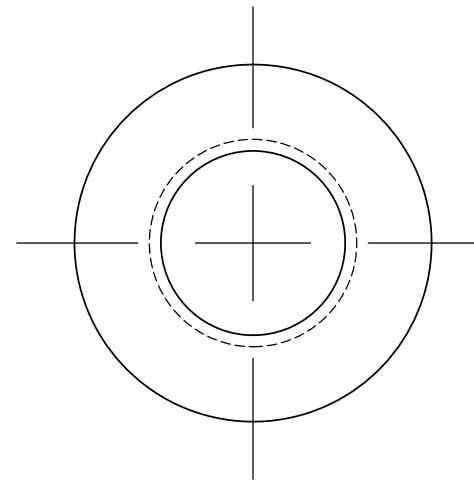

NOTES:  
1. MATERIAL: NYLON 6/6 UL 94 V-2  
2. COLOR: NATURAL

P	SEE CO 200276 FOR CHANGES	SK	11/12/08
-	SEE ENGINEERING FOR REV A-O	-	-
REV.	DESCRIPTION	ENGR.	DATE

TITLE: <b>MOLDED NYLON INSULATORS</b>				DWG IN IN [MM]		FINAL	
CREATED USING SOLIDWORKS	FILE #: MNI	DWN: SM	APP: SM	FINAL			
TOLERANCES UNLESS NOTED .XX=±.010 .XXX=±.005 FRAC.=±1/64 ANG.=±1°	SHEET: 1 OF 1	SHEET SIZE: B	DT: 10/01/04	CHKD: SJ	PART #		PRINT TYPE
RE: <b>RICHCO, INC.</b>		<b>RICHCO, INC.</b> ENG@RICHCO-INC.COM (773) 539-4060		<b>SEE TABLE</b>		<b>CA</b>	