

LOC	DIST	REVISIONS					
		P	LTN	DESCRIPTION	DATE	DWN	APVD
ES	00	A		RELEASE	10MAY2010	JY	SY
		B		REVISED PER ECO-14-000886	20FEB2014	JW	SH

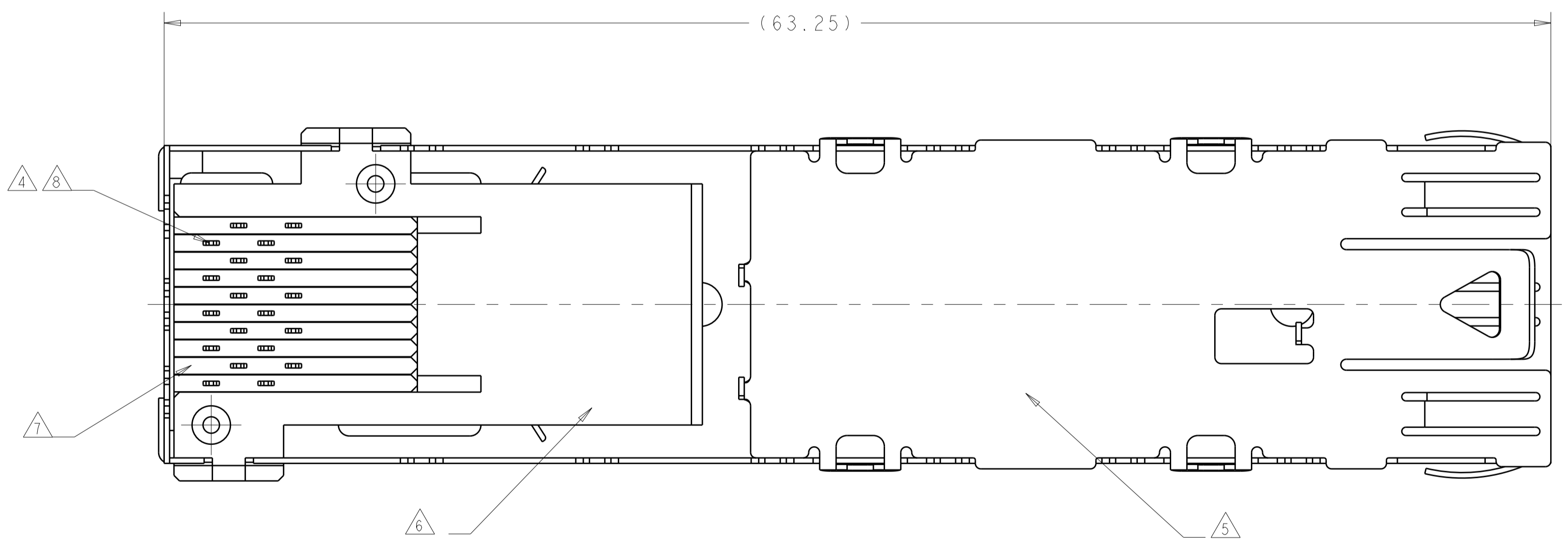

- ① DATUM AND BASIC DIMENSION TO BE DETERMINED BY CUSTOMER.
- ② INTERPRETATION OF DATUM REFERENCE FRAME IN ACCORDANCE WITH SECT 4.4.1.1 OF ASME Y14.5M-1994.
- ③ TOP OF PT CONNECTOR TO BE 0-0.15 FROM INSIDE SURFACE OF CAGE.
- ④ COPPER ALLOY.
- ⑤ NICKEL SILVER ALLOY (NO PLATING).
- ⑥ LCP, HIGH TEMPERATURE, UL 94V-0 RATED, BLACK.
- ⑦ POLYESTER, UL 94V-0 RATED, BLACK.
- ⑧ CONTACT MATING AREA: SURFACE TREATMENT OVER 0.76um MIN GOLD PER ASTM B 488 OVER 1.27um MIN NICKEL PER QQ-N-290. NEEDLE EYE: 1.25um MIN TIN PER ASTM B 545 OVER 1.25um MIN NICKEL PER QQ-N-290. REMAINDER OF CONTACT: 0.76um MIN NICKEL PER QQ-N-290.
- ⑨ DATE CODE AND PART NUMBER IN APPROXIMATE LOCATION SHOWN

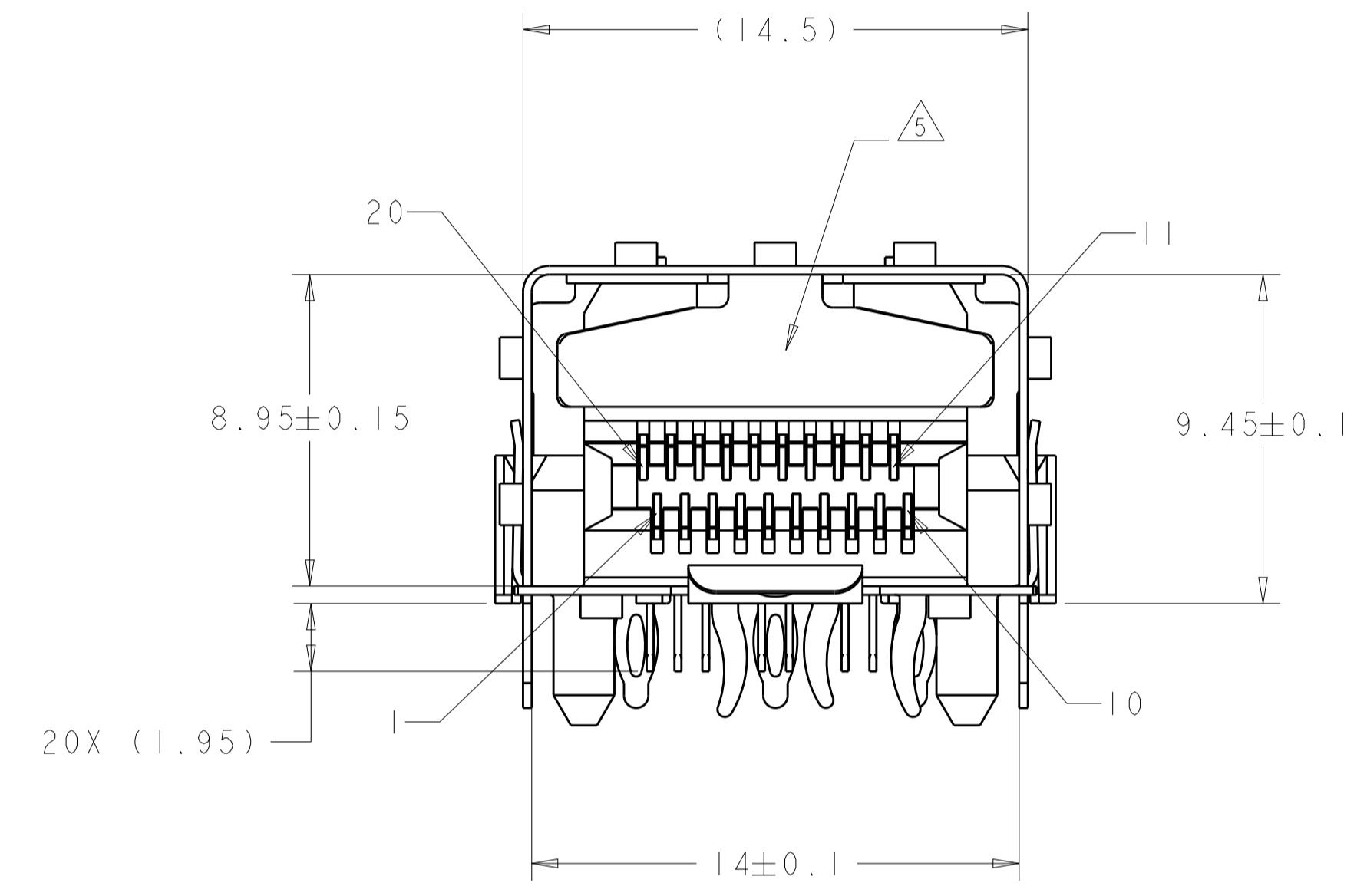
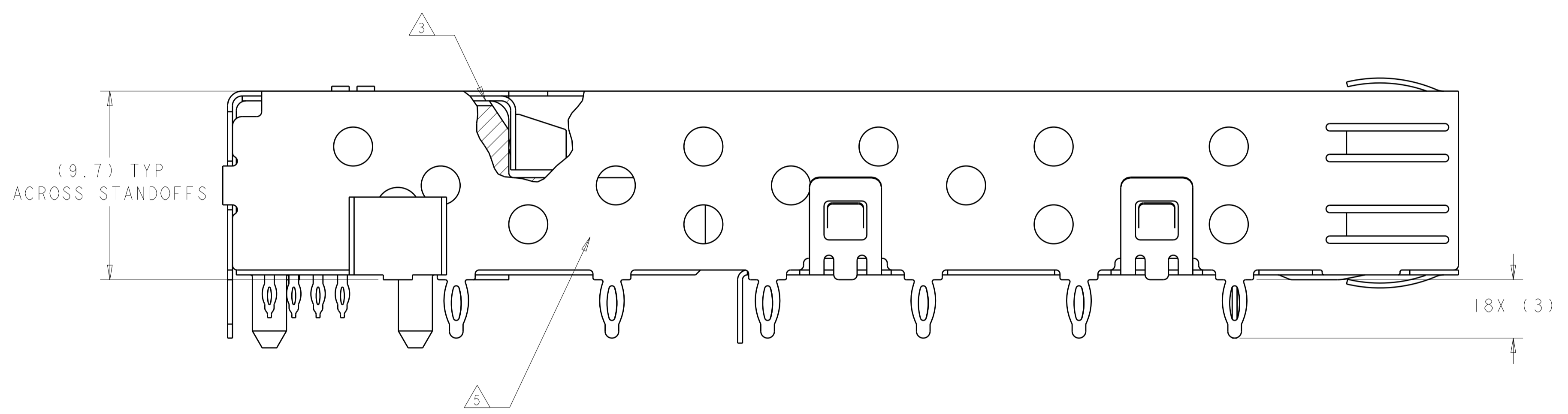
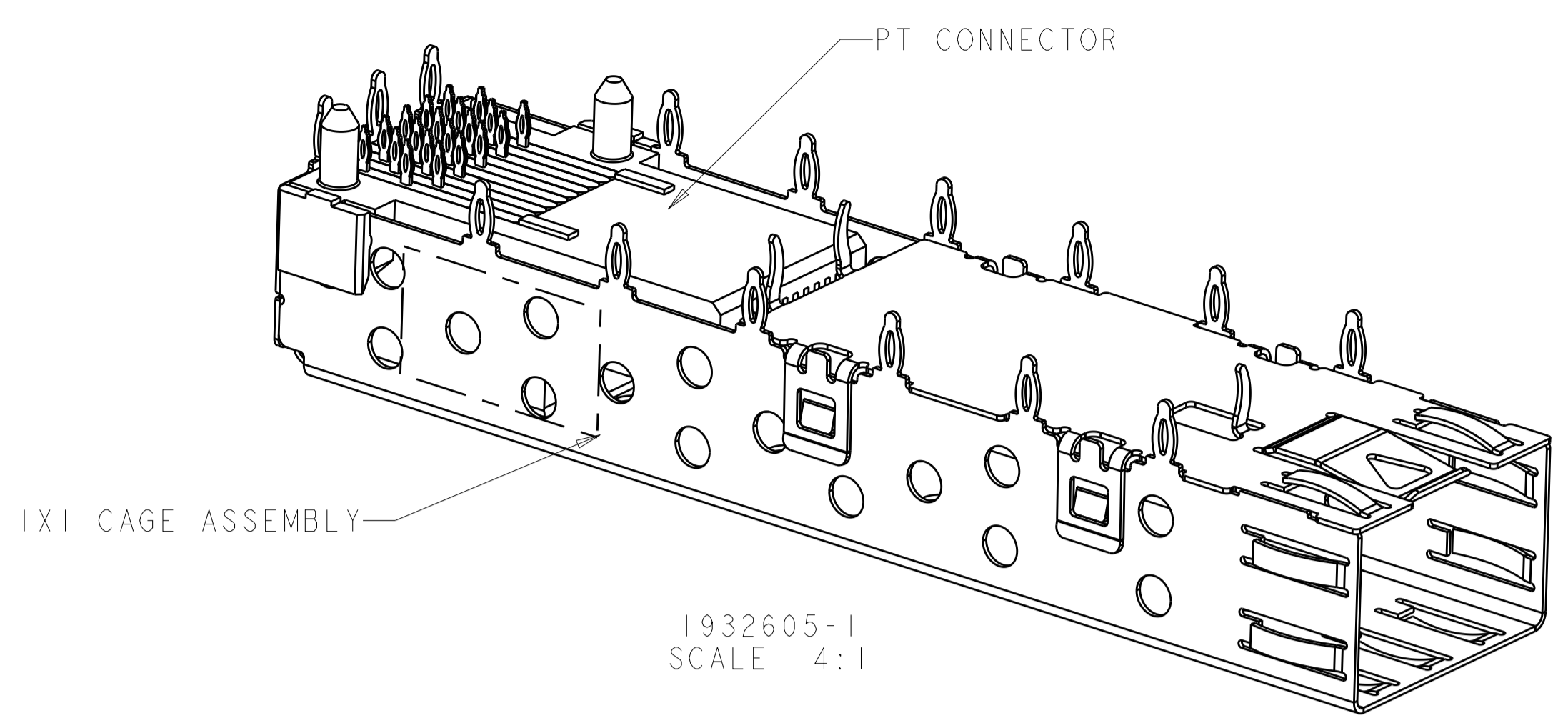
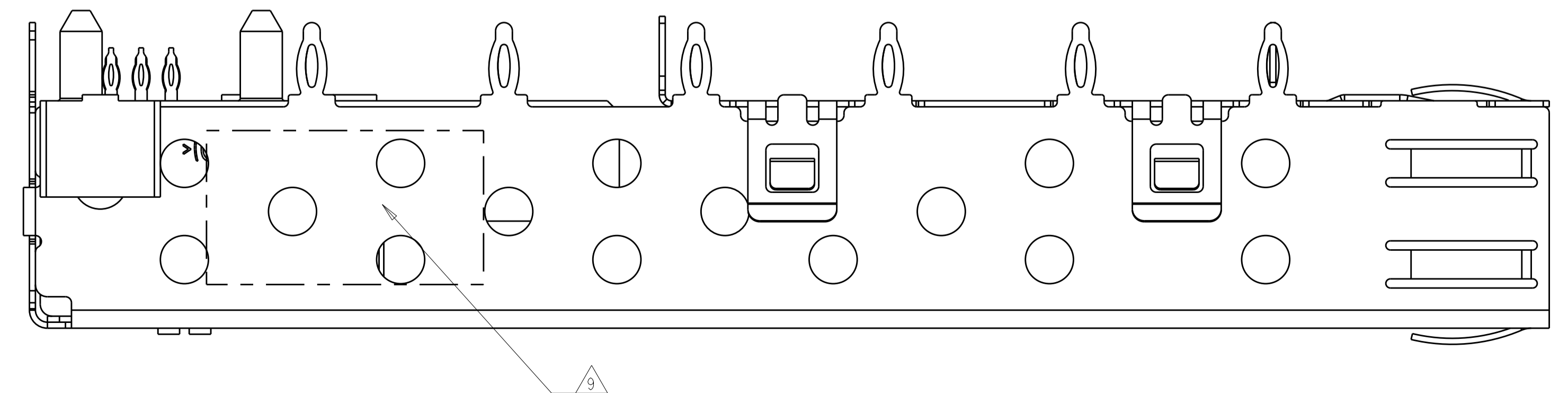

1932605-1
PART NUMBER

THIS DRAWING IS A CONTROLLED DOCUMENT.		DWN: JASON YANG 08APR2010	TE Connectivity	
DIMENSIONS: mm		CHK: SUNY ZHAO 08APR2010		
TOLERANCES UNLESS OTHERWISE SPECIFIED:		APVD: STEVEN YAO 08APR2010	NAME: CAGE AND PT CONNECTOR ASSEMBLY, 1x1, PRESS FIT, SFP	
0 PLC ±	1 PLC ±0.1	PRODUCT SPEC: 108-2161	SIZE: A1	
2 PLC ±	3 PLC ±	APPLICATION SPEC: 114-13121	CAGE CODE: C=1932605	
4 PLC ±	ANGLES ±	WEIGHT: -	RESTRICTED TO: -	
MATERIAL: SEE NOTE		FINISH: SEE NOTE	SCALE: 6:1	
CUSTOMER DRAWING		SHEET 1 OF 3		REV B

LOC	DIST	REV	DATE	BY	APPV
ES	00				

REVISIONS					
NO.	DATE	DESCRIPTION	BY	APPV	REV
-	-	SEE SHEET 1	-	-	-

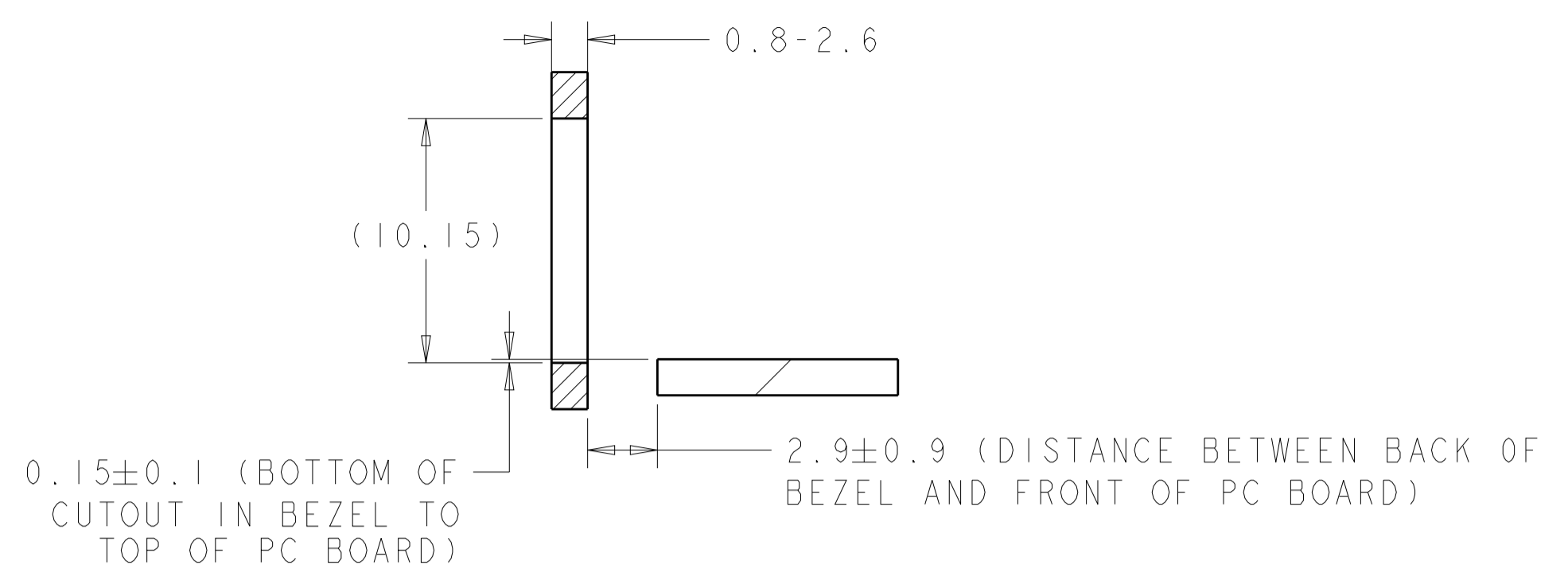
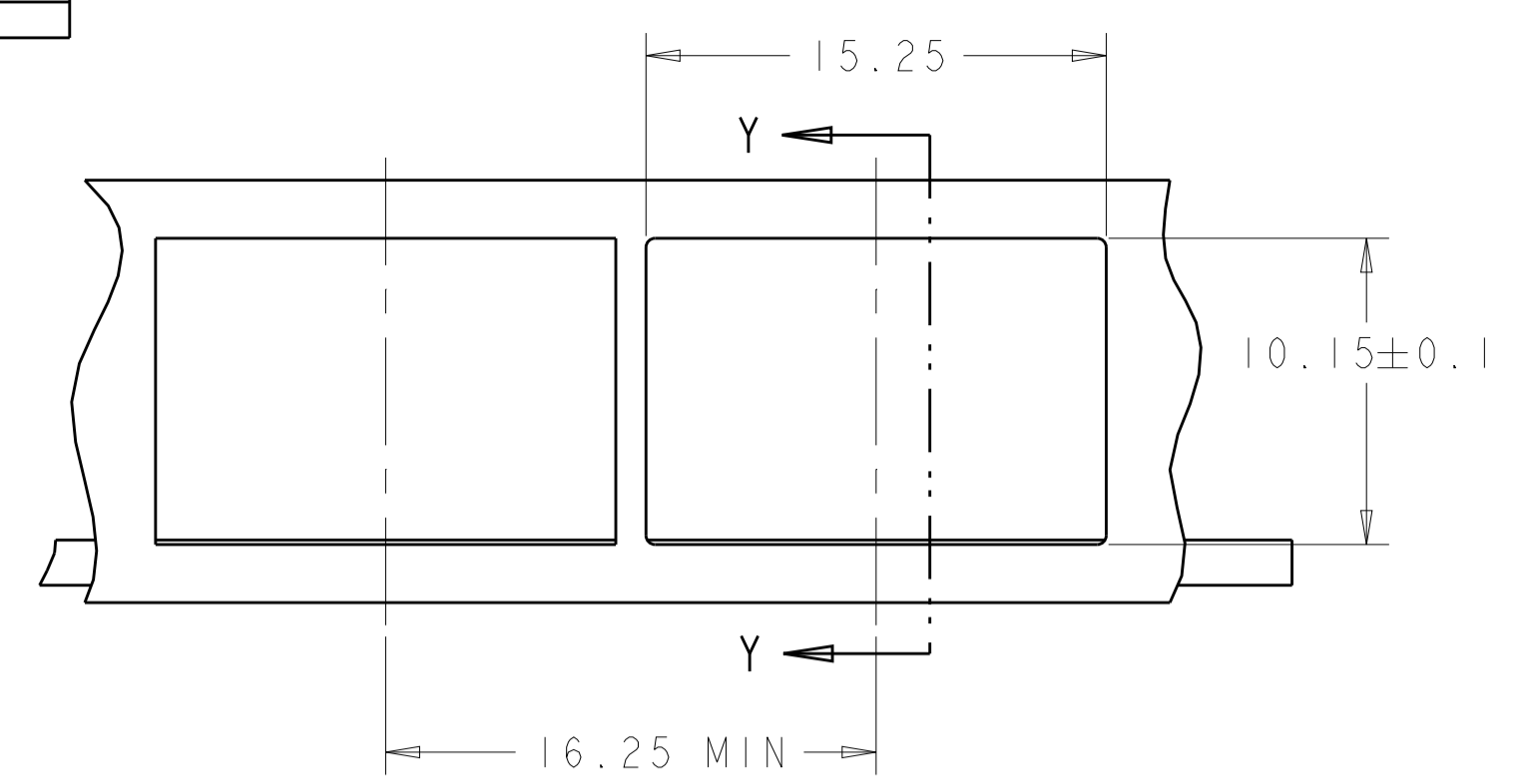

RECOMMENDED BEZEL CUTOUT AND PC BOARD AND BEZEL POSITION
SCALE 4:1

SECTION Y-Y

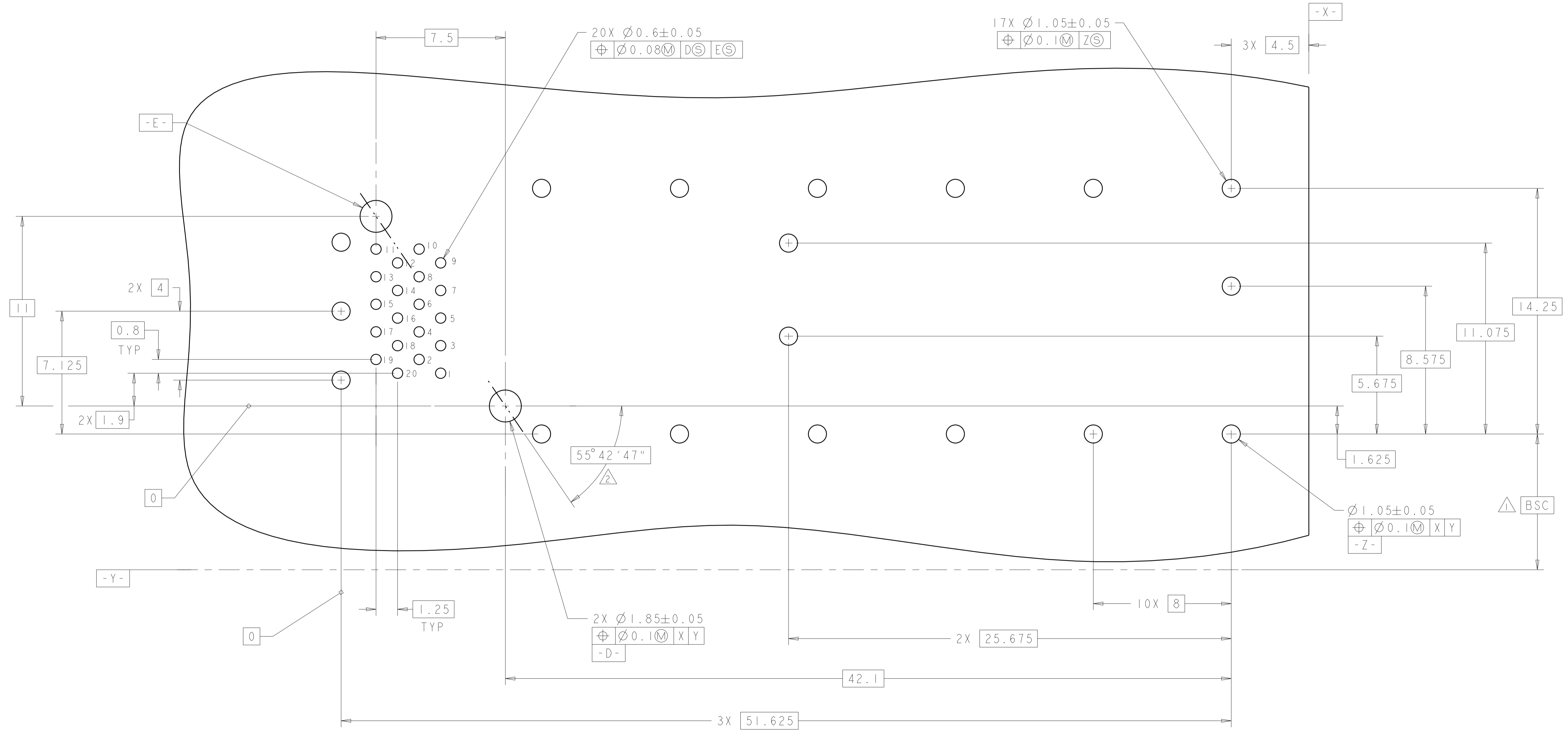

SFP HOST BOARD
MECHANICAL LAYOUT
SCALE 8:1

THIS DRAWING IS A CONTROLLED DOCUMENT.		DWN: JASON YANG 08APR2010 CHK: SUNY ZHAO 08APR2010 APV: STEVEN YAO 08APR2010	TE Connectivity
DIMENSIONS: mm TOLERANCES UNLESS OTHERWISE SPECIFIED: 0 PLC ± 1 PLC ±0.1 2 PLC ± 3 PLC ± 4 PLC ± ANGLES ±		NAME: CAGE AND PT CONNECTOR ASSEMBLY, 1x1, PRESS FIT, SFP PRODUCT SPEC: 108-2161 APPLICATION SPEC: 114-13121 WEIGHT: - CUSTOMER DRAWING	
MATERIAL: SEE NOTE		FINISH: SEE NOTE	SIZE: A1 CAGE CODE: C=1932605 SCALE: 1:1 SHEET: 2 OF 3 REV: B

LOC	DIST	REVISIONS			
P	LTN	DESCRIPTION	DATE	DMN	APVD
ES	00	SEE SHEET 1			

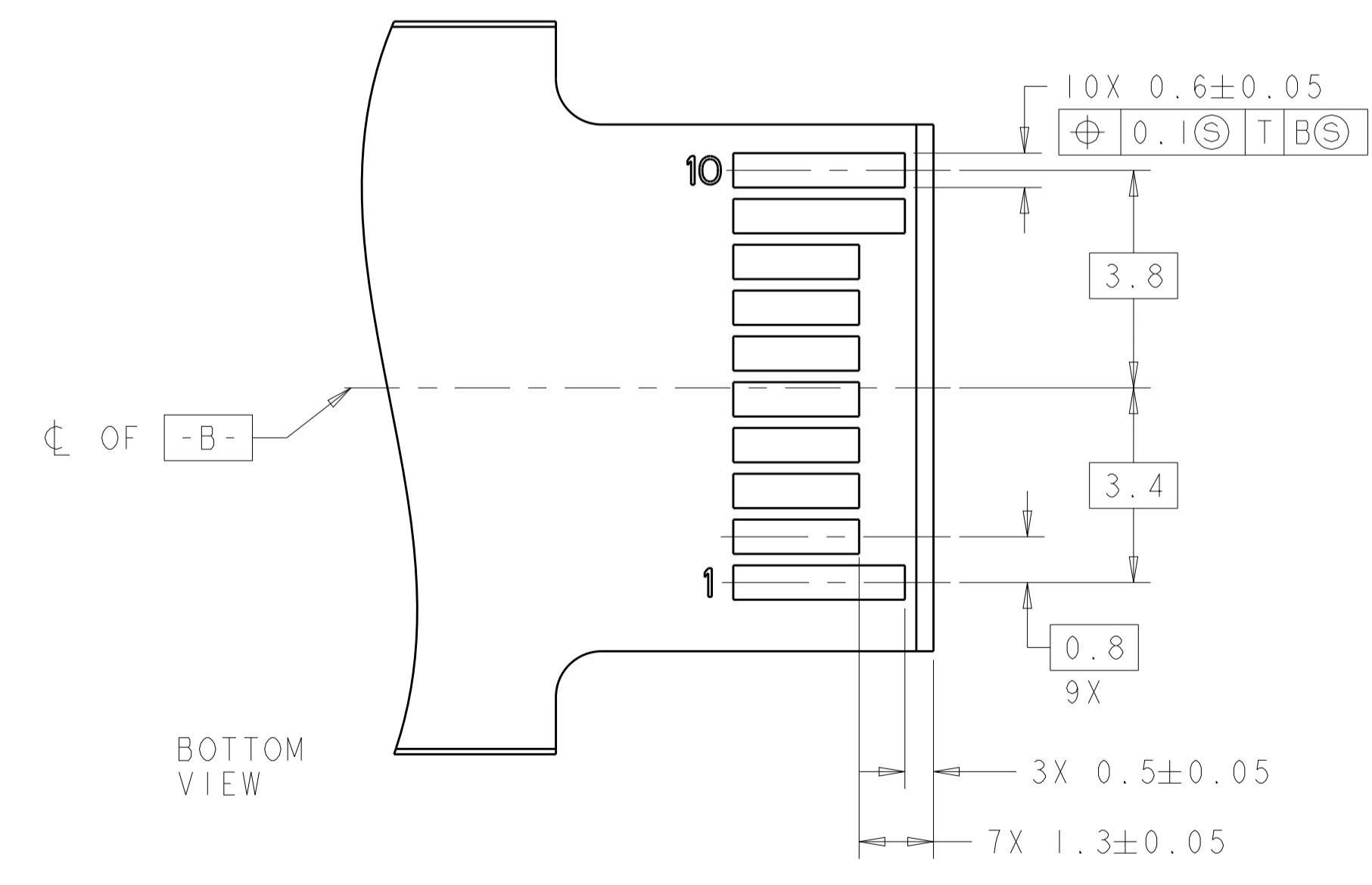
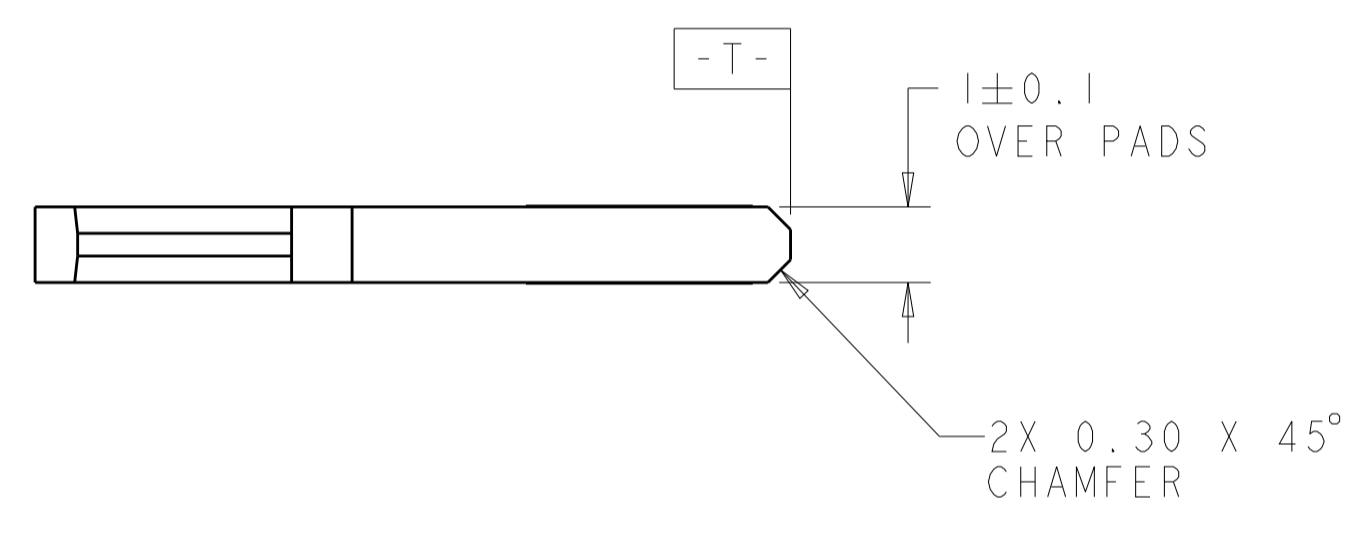
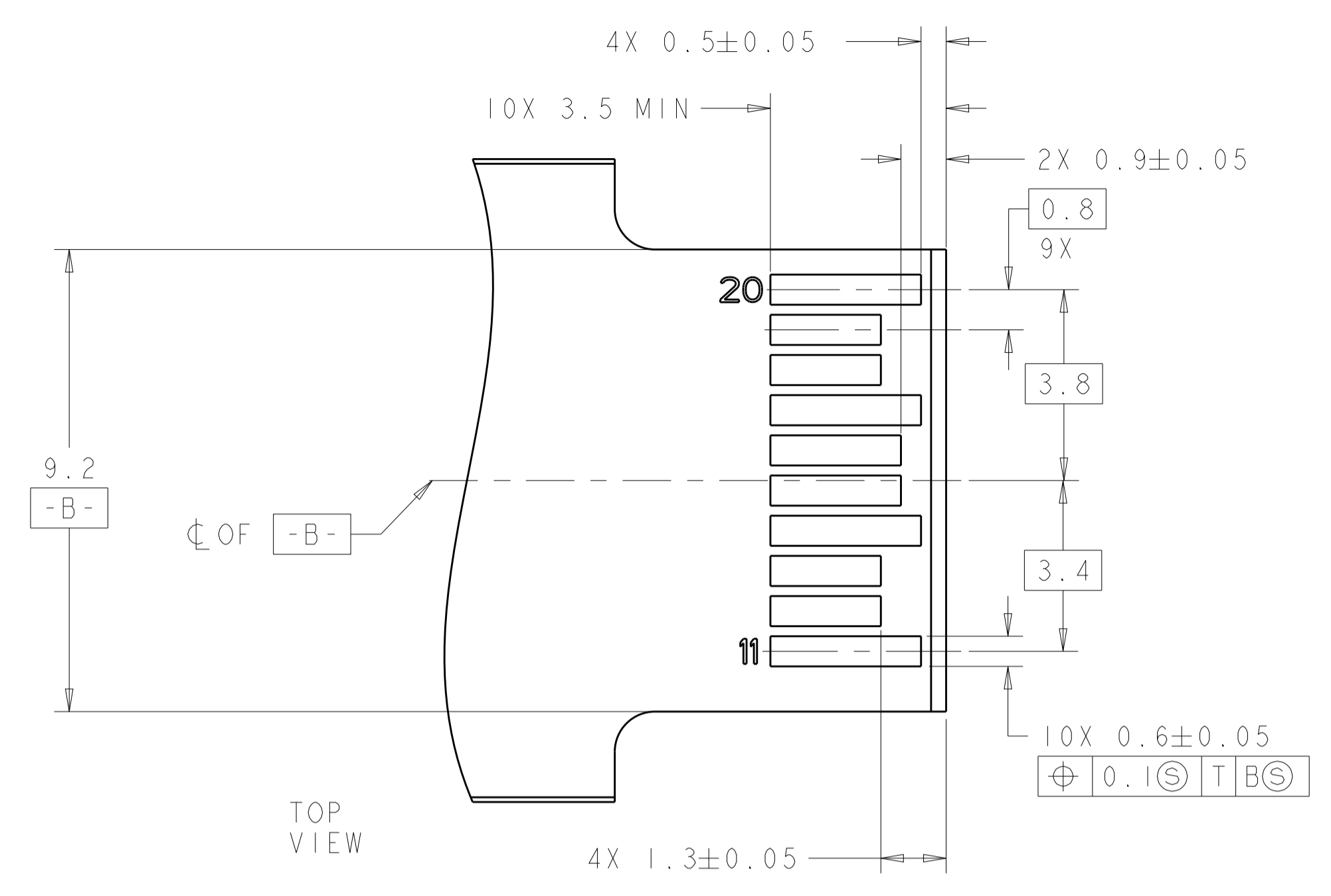

RECOMMENDED LAYOUT FOR MATING TRANSCEIVER PCB
SCALE 10:1

THIS DRAWING IS A CONTROLLED DOCUMENT.		DMN: JASON YANG 08APR2010	TE Connectivity
DIMENSIONS: mm		CHK: SUNY ZHAO 08APR2010	
TOLERANCES UNLESS OTHERWISE SPECIFIED:		APVD: STEVEN YAO 08APR2010	NAME: CAGE AND PT CONNECTOR ASSEMBLY, 1x1, PRESS FIT, SFP
0 PLC ±		PRODUCT SPEC: 108-2161	SIZE: A1
1 PLC ±0.1		APPLICATION SPEC: 114-13121	CAGE CODE: C=1932605
2 PLC ±		WEIGHT: -	RESTRICTED TO: -
3 PLC ±		FINISH: -	SCALE: 11:1
4 PLC ±		SEE NOTE	SHEET 3 OF 3
ANGLES ±		CUSTOMER DRAWING	REV B