

STRAIGHT HDC CONNECTOR C-C MALE CRIMP

R214.318.702

CABLE 2.6/50 S BLK20

Series : **HDC 43**

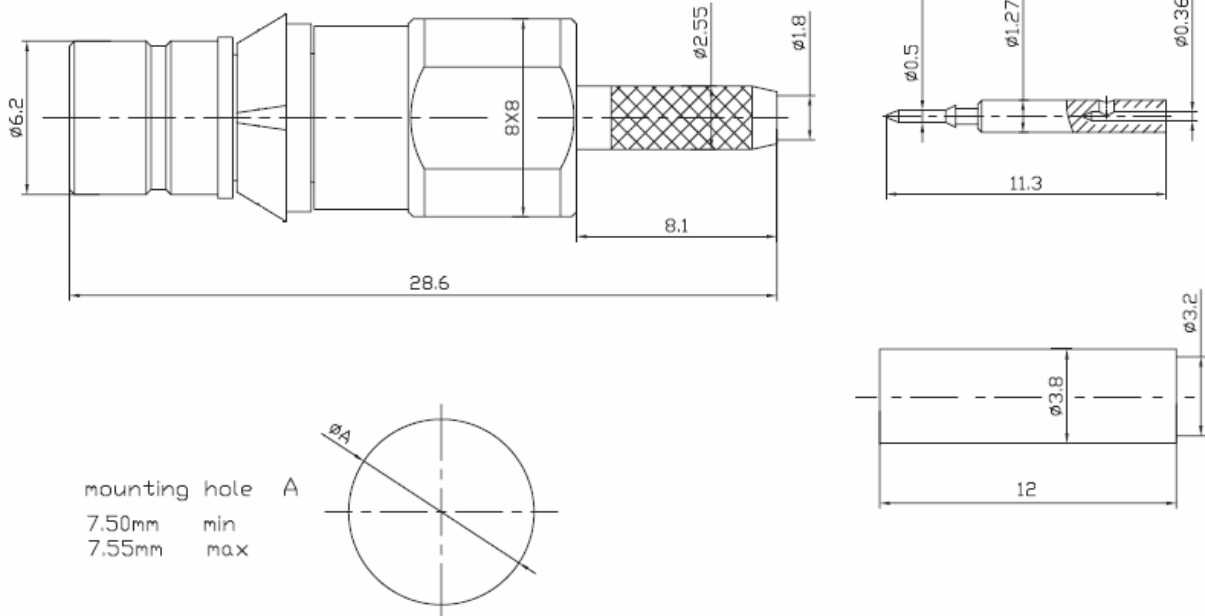

Panel thickness: 3.75~4.95mm

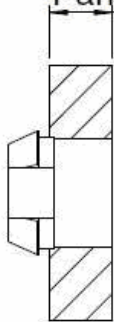

All dimensions are in mm.

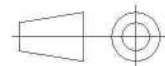

COMPONENTS	MATERIALS	PLATING (μm)
BODY	BRASS	NICKEL
CENTER CONTACT	BRONZE	-
OUTER CONTACT	BRASS	-
INSULATOR	PTFE	
GASKET	-	
OTHERS PARTS	BRASS	NICKEL
-	-	-
-	-	-

Issue : 1139 E

In the effort to improve our products, we reserve the right to make changes judged to be necessary.



STRAIGHT HDC CONNECTOR C-C MALE CRIMP

R214.318.702

CABLE 2.6/50 S BLK20

Series : **HDC 43**

PACKAGING

Standard	Unit	Other
20		Contact us

SPECIFICATION

ELECTRICAL CHARACTERISTICS

Impedance		75 Ω
Frequency		0-3 GHz
VSWR	1.25* +	0,0000 x F(GHz) Maxi
Insertion loss		AD √F(GHz) dB Maxi
RF leakage	- (NA - F(GHz)) dB Maxi
Voltage rating		500 Veff Maxi
Dielectric withstanding voltage		1500 Veff mini
Insulation resistance		500 MΩ mini

CABLE ASSEMBLY

Stripping	a	b	c	d	e	f
mm	4,50	8,00	21,0	0,00	16,5	0,00

Assembly instruction :

Recommended cable(s)

RG 179

RG 187

Characteristics indicated on this data sheet are those that can be achieved with the highest performance cable. Intrinsic limitations of the cable may diminish the performance of the assembly

Cable retention

- pull off **60** N mini
- torque **NA** N.cm

MECHANICAL CHARACTERISTICS

Center contact retention		
Axial force – Mating end	22	N mini
Axial force – Opposite end	NA	N mini
Torque	NA	N.cm mini

TOOLING

Part Number	Description	Hexagon
.	.	.
R282.281.010	CRIMPING TOOL MH800	
R282.287.000	CRIMPING TOOL Q92316	
R282.265.001	CRIMPING DIES Q92441	HEX 3.25

Recommended torque		
Mating	NA	N.cm
Panel nut	NA	N.cm
Clamp nut	NA	N.cm
A/F clamp nut	0,0000	mm

Mating life	250	Cycles mini
Weight	6,0000	g

OTHER CHARACTERISTICS

* 0-1GHz

ENVIRONMENTAL

Operating temperature	-40/+100	° C
Hermetic seal	NA	Atm.cm3/s
Panel leakage	NA	

Issue : **1139 E**

In the effort to improve our products, we reserve the right to make changes judged to be necessary.



STRAIGHT HDC CONNECTOR C-C MALE CRIMP

R214.318.702

CABLE 2.6/50 S BLK20

Series : **HDC 43**

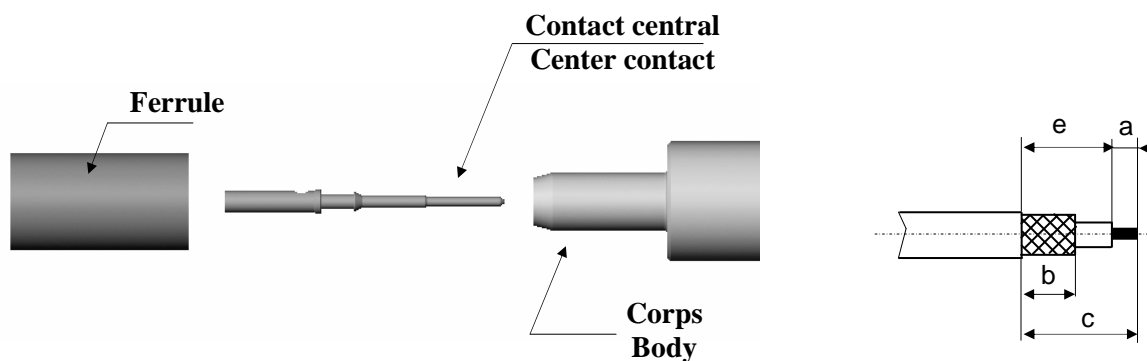

Fig - 1

Slide the ferrule onto the cable.
Strip the cable.

Glisser la ferrule sur le câble.
Dénuder le câble suivant les cotes ci dessus.

Fig - 2

Place adaptor onto the cable until it bottoms against dielectric.
Slide the centre contact into the adaptor until it bottoms against the cable dielectric.
Crimp the centre contact with crimping tool (see connector TDS).

Placer l'adaptateur sur le câble en buté contre le diélectrique
Monter le contact central dans l'adaptateur en butée contre le diélectrique du câble.
Sertir le contact central avec la pince (voir fiche technique du connecteur).

Fig - 3

Fan the braid.

Epanouir la tresse .

Fig - 4

Slide the cable into the body until it bottoms against insulator (push home until a click is felt) and slide the ferrule onto the braid .

Monter le câble dans le corps en butée contre l'isolant jusqu'à encliquetage du contact central.
Glisser la ferrule sur la tresse.

Fig - 5

Slide the ferrule over the braid.
Crimp the ferrule with crimping tool (see connector TDS).
Cut the excess of braid if necessary.

Sertir la ferrule avec la pince (voir fiche technique du connecteur).
Enlever le surplus de tresse.

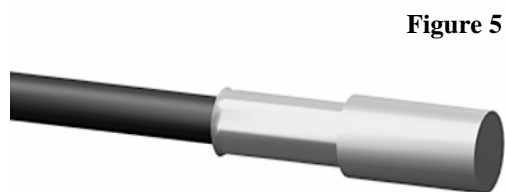
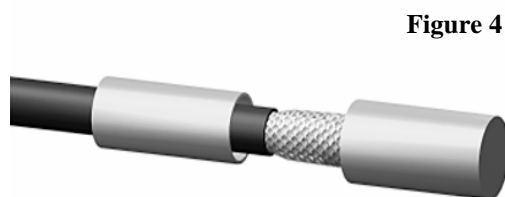
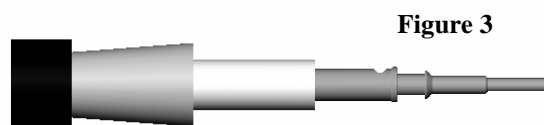
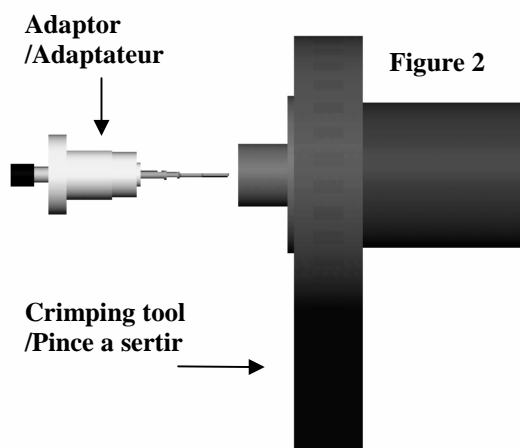

Issue : 1139 E

In the effort to improve our products, we reserve the right to make changes judged to be necessary.

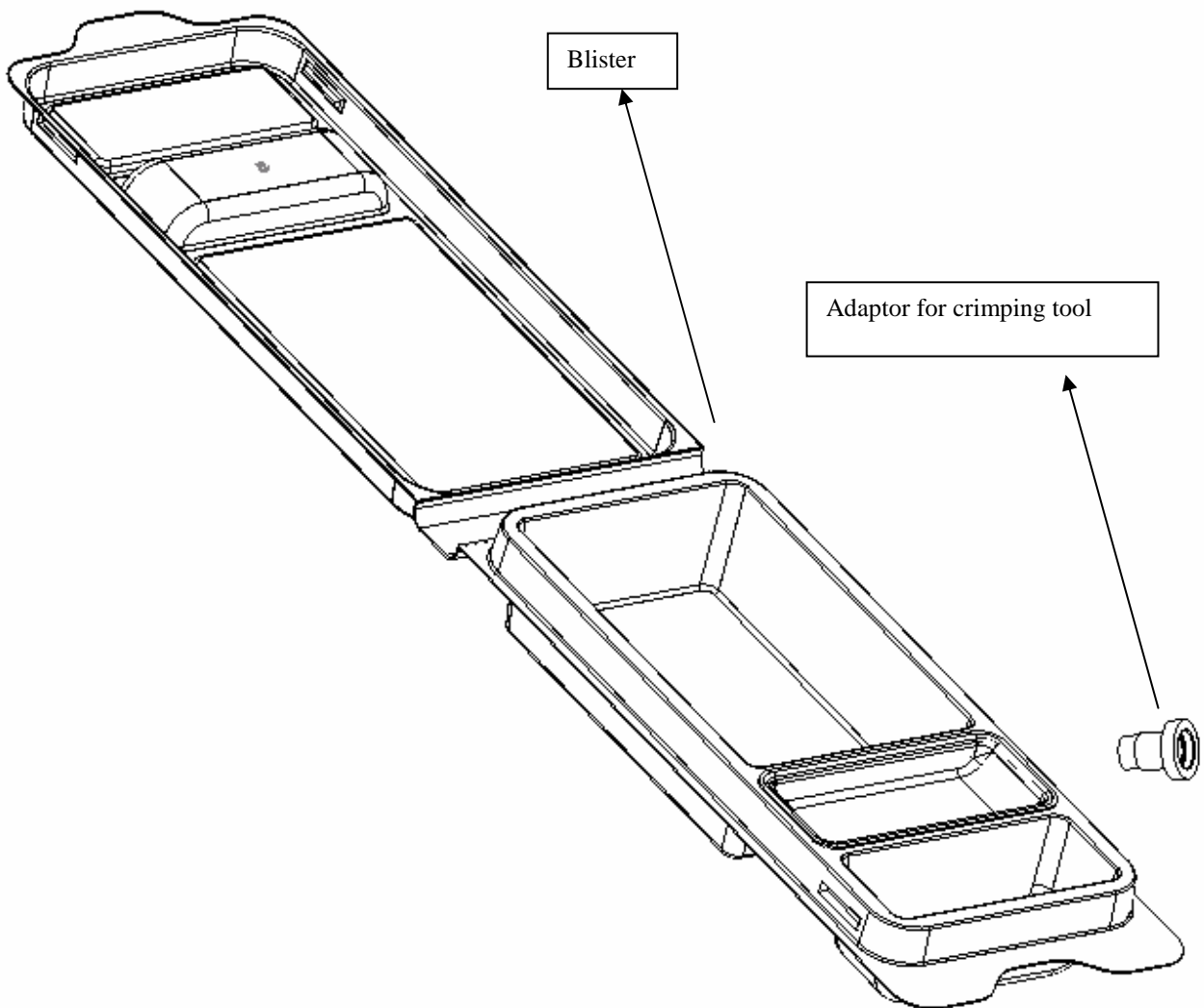

STRAIGHT HDC CONNECTOR C-C MALE CRIMP**R214.318.702****CABLE 2.6/50 S BLK20**Series : **HDC 43****PACKAGING – BLK (BULK)****Issue : 1139 E**

In the effort to improve our products, we reserve the right to make changes judged to be necessary.

RADIALL 