

CAPPED IDC 26-28 AWG: 9175-700

General Information



The market and applications for simple and reliable discrete Wire-to-Board connectors continue to evolve. KYOCERA AVX first introduced the 9175 series of surface mountable Insulation Displacement Connectors (IDC) in 2006. Developed for harsh industrial and automotive applications, these connectors have been used in hundreds of applications from today's "Smart Meter" all the way down to a simple sensor termination to a PCB. Size and performance has been one of the key factors for selecting this connector in terminating 26-28AWG wires to a PCB.

The next generation of IDC connector moves beyond all of the technical and performance attributes to address the "User Friendliness" of the product. By changing the insulator from acting as a connector body and make it more like a contact carrier, the insulator becomes the wire location and insertion aid without any special tools. The wire is just inserted into the cap (no stripping required) and then pressed down to provide a secure "Gas Tight" termination. This configuration simplifies and cost reduces the entire wire termination process for connecting discrete wires to a PCB.

APPLICATIONS

- Connecting discrete wire components to a PCB
- Bringing power and signals onto a PCB
- Daisy chaining PCB's together to create a continuous string
- Reference Product Specification 201-01-140

FEATURES AND BENEFITS

- IDC contact provides a gas-tight connection to the PCB for long term reliability
- Plastic cap retains the contacts in position prior to automatic placement, then acts as the assembly tool to terminate the wires; no special tooling.
- Tested to automotive levels on shock, vibration and temperature cycling for reliability
- Identical contact and footprint pattern to the existing 9175 for full backward compatibility and functionality
- The IDC contact reduces the total applied cost versus solder or crimp processes
- Connectors are available in two configurations for maximum flexibility; End and Through Wire

ELECTRICAL

- Current Rating: 1 Amps / Contact
- Voltage Rating: 150 VAC

ENVIRONMENTAL

- Operating Temperature: -40°C to +125°C

MECHANICAL

- Insulator Material: Nylon UL94VO
- Contact Material: Phosphor Bronze
- Plating: Tin over Nickel

HOW TO ORDER

00	9175	00X									
Prefix	Series	Number of Ways									
		<table border="1"> <thead> <tr> <th>Code</th> <th>No of Ways</th> <th>Details</th> </tr> </thead> <tbody> <tr> <td>002</td> <td>2</td> <td>Pages 11 & 13</td> </tr> <tr> <td>003</td> <td>3</td> <td>Pages 12 & 14</td> </tr> </tbody> </table>	Code	No of Ways	Details	002	2	Pages 11 & 13	003	3	Pages 12 & 14
Code	No of Ways	Details									
002	2	Pages 11 & 13									
003	3	Pages 12 & 14									

70X									
Wire Gauge Size Cap Pre-Assembled									
<table border="1"> <thead> <tr> <th>Code</th> <th>Accepted Wire Gauge</th> <th>Wire Insulation</th> </tr> </thead> <tbody> <tr> <td>701</td> <td>28 Gauge Solid or Stranded</td> <td>Min Ø 0.70 Max Ø 1.00</td> </tr> <tr> <td>702</td> <td>26 Gauge Solid or Stranded</td> <td>Min Ø 0.80 Max Ø 1.20</td> </tr> </tbody> </table>	Code	Accepted Wire Gauge	Wire Insulation	701	28 Gauge Solid or Stranded	Min Ø 0.70 Max Ø 1.00	702	26 Gauge Solid or Stranded	Min Ø 0.80 Max Ø 1.20
Code	Accepted Wire Gauge	Wire Insulation							
701	28 Gauge Solid or Stranded	Min Ø 0.70 Max Ø 1.00							
702	26 Gauge Solid or Stranded	Min Ø 0.80 Max Ø 1.20							

X
Insulator Color
9 = UL White 8 = UL Black Special Order

X												
Cap Options												
<table border="1"> <thead> <tr> <th>Code</th> <th>Cap Option</th> <th>Description</th> <th>Detail</th> </tr> </thead> <tbody> <tr> <td>0</td> <td>Through Wire</td> <td>Allows wire to be terminated at any point</td> <td>Page 11-12</td> </tr> <tr> <td>9</td> <td>Wire Stop</td> <td>Terminates end of wire End Protected by stop face</td> <td>Pages 13-14</td> </tr> </tbody> </table>	Code	Cap Option	Description	Detail	0	Through Wire	Allows wire to be terminated at any point	Page 11-12	9	Wire Stop	Terminates end of wire End Protected by stop face	Pages 13-14
Code	Cap Option	Description	Detail									
0	Through Wire	Allows wire to be terminated at any point	Page 11-12									
9	Wire Stop	Terminates end of wire End Protected by stop face	Pages 13-14									

6
Plating Option
6 = Pure Tin all over

Certification: UL File #E90723



CAPPED IDC 26-28 AWG: 9175-700

2 Position - Through Wire

26-28 AWG 2 WAY IDC CONNECTOR THROUGH WIRE CAPPED IDC

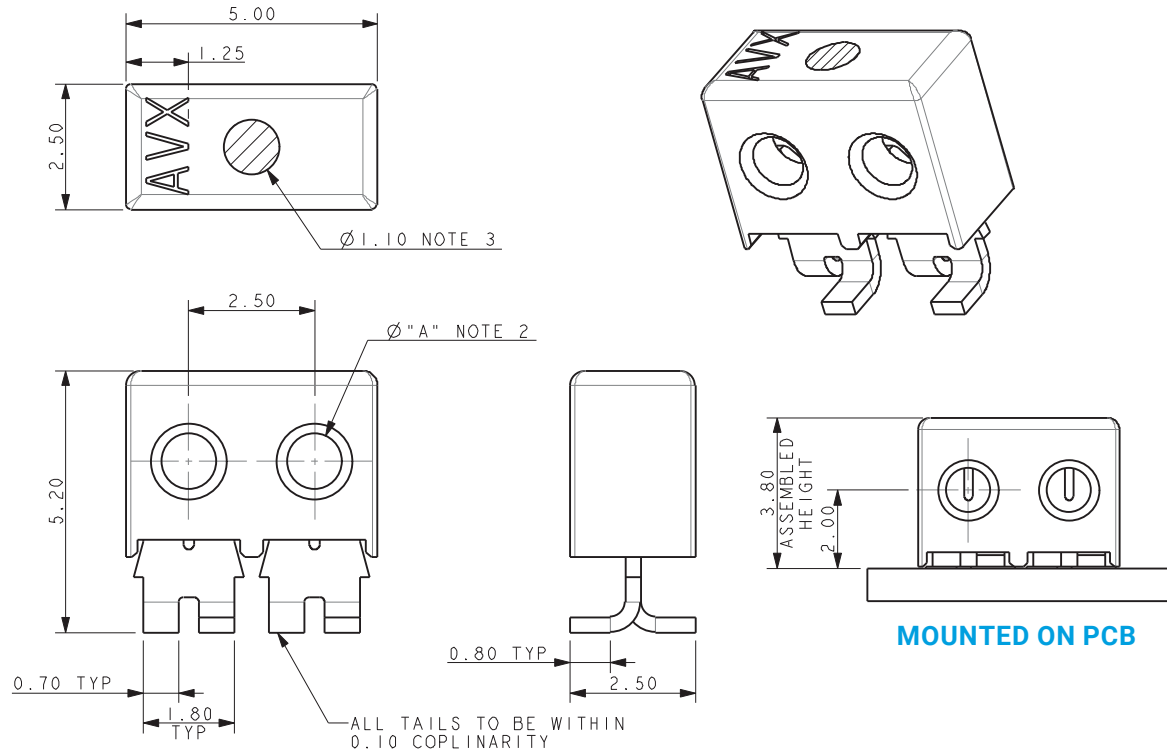

MOUNTED ON PCB

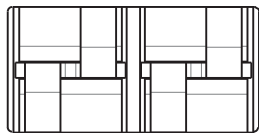

Code	Wire Gauge	Diameter A
701	28AWG	1.10
702	26AWG	1.30

NOTES:

- 2 WAY CONNECTOR FOR IDC WIRE TO BOARD CONNECTION. PRE-ASSEMBLED THROUGH WIRE CAP.
- CONTACT/CAP TO MATCH 26AWG AND 28AWG WIRES. SOLID OR STRANDED CONDUCTOR. MAXIMUM INSULATOR 1.00 MM DIAMETER.
- FLAT FACE ON TOP OF CAP TO AID PICK AND PLACE ASSEMBLY.
- FOR FULL PRODUCT SPECIFICATION ON STANDARD CONNECTORS REFER TO ELCO SPEC 201-01-139. UL COMPONENTS REFER TO ELCO SPEC 201-01-139UL.
- ASSEMBLY PROCEDURE, REFER TO APPLICATION NOTES 201-01-140.
- GENERAL TOLERANCE ± 0.20 UNLESS STATED.
- PACKED IN TAPE AND REEL, QUANTITY PER REEL 1000.
- CONNECTOR OUTLINE.
- CONTACT MATERIAL: TIN PLATED COPPER ALLOY.
- INSULATOR MATERIAL: HIGH TEMPERATURE NYLON, GLASS FILLED, UL94 V-0. COLOR REFER TO PAGE 10.
- FOR UL CODES UL REFERENCE E90723 (US AND CANADA).

PACKING DETAILS

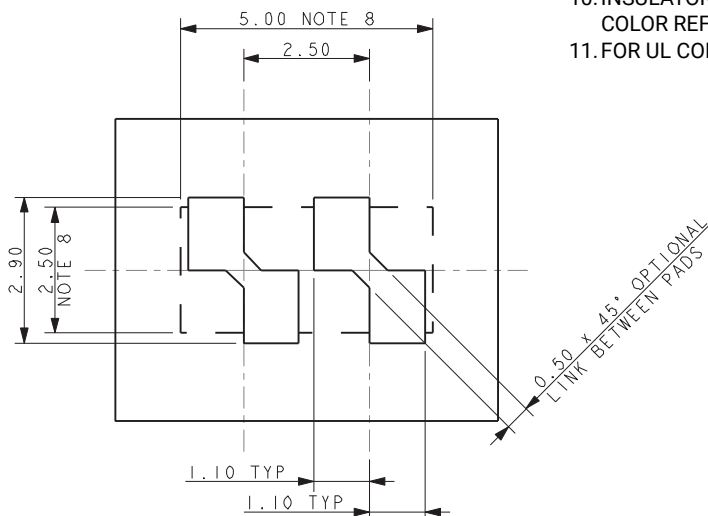

SUGGEST PCB LAYOUT

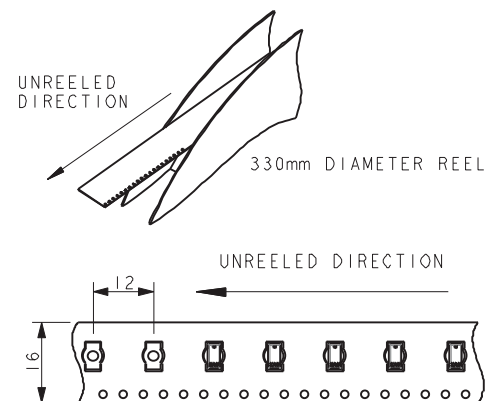

QUANTITY PER REEL 1000

CAPPED IDC 26-28 AWG: 9175-700

3 Position - Through Wire

26-28 AWG 3 WAY IDC CONNECTOR THROUGH WIRE CAPPED IDC

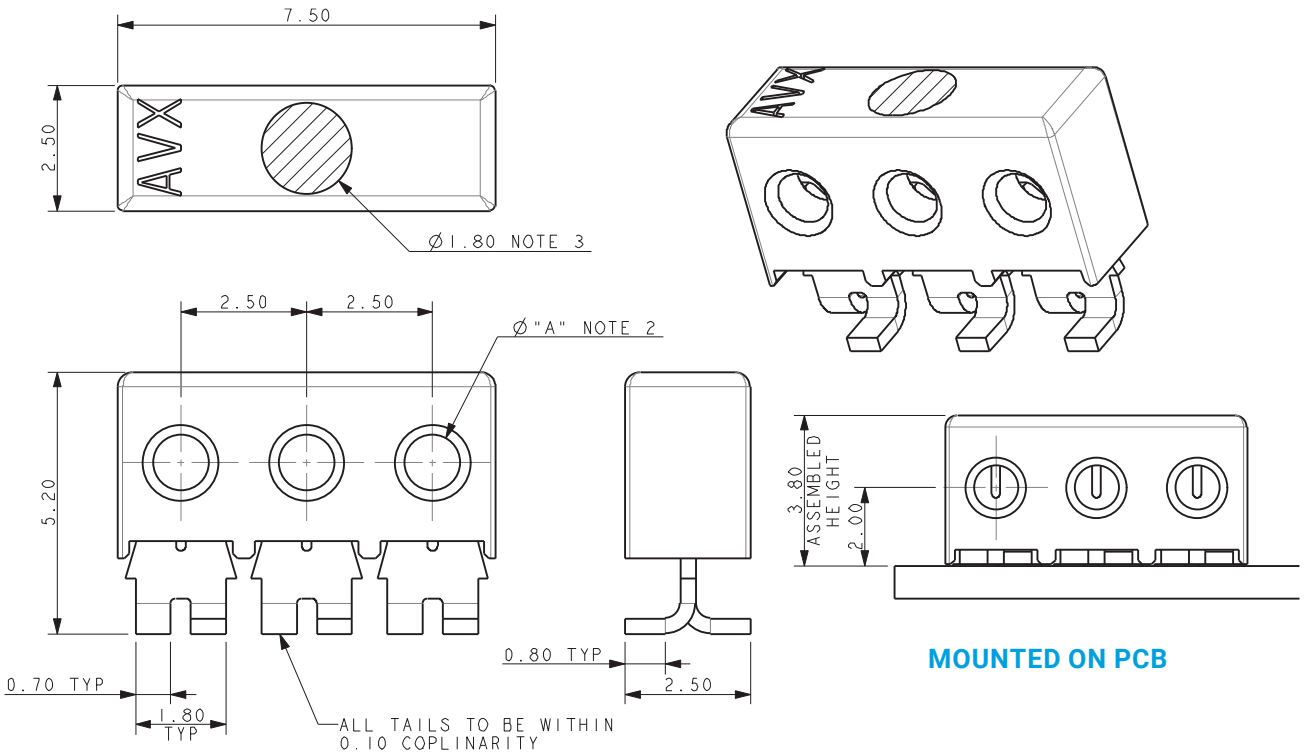

MOUNTED ON PCB

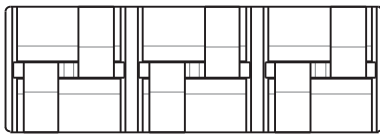

Code	Wire Gauge	Diameter A
701	28AWG	1.10
702	26AWG	1.30

NOTES:

1. WAY CONNECTOR FOR IDC WIRE TO BOARD CONNECTION. PRE-ASSEMBLED THROUGH WIRE CAP.
2. CONTACT/CAP TO MATCH 26AWG AND 28AWG WIRES. SOLID OR STRANDED CONDUCTOR. MAXIMUM INSULATOR 1.00 MM DIAMETER.
3. FLAT FACE ON TOP OF CAP TO AID PICK AND PLACE ASSEMBLY.
4. FOR FULL PRODUCT SPECIFICATION ON STANDARD CONNECTORS REFER TO ELCO SPEC 201-01-139. UL COMPONENTS REFER TO ELCO SPEC 201-01-139UL.
5. ASSEMBLY PROCEDURE, REFER TO APPLICATION NOTES 201-01-140.
6. GENERAL TOLERANCE ± 0.20 UNLESS STATED.
7. PACKED IN TAPE AND REEL, QUANTITY PER REEL 1000.
8. CONNECTOR OUTLINE.
9. CONTACT MATERIAL: TIN PLATED COPPER ALLOY.
10. INSULATOR MATERIAL: HIGH TEMPERATURE NYLON, GLASS FILLED, UL94 V-0. COLOR REFER TO PAGE 10.
11. FOR UL CODES UL REFERENCE E90723 (US AND CANADA).

PACKING DETAILS

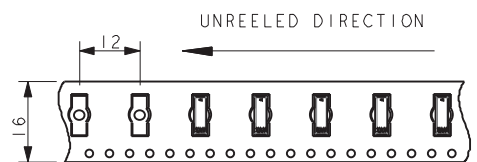
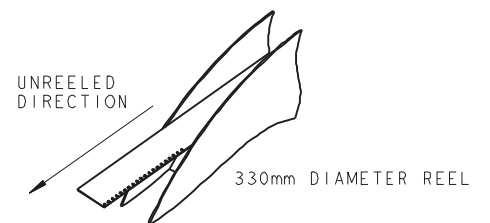

QUANTITY PER REEL 1000

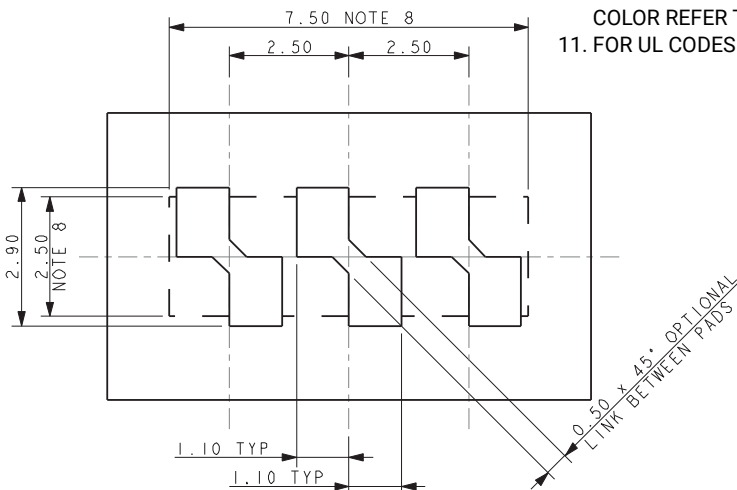

SUGGEST PCB LAYOUT

CAPPED IDC 26-28 AWG: 9175-700

2 Position - Wire Stop



26-28 AWG 2 WAY IDC CONNECTOR WIRE STOP CAPPED IDC

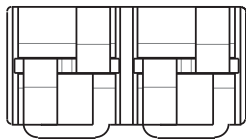
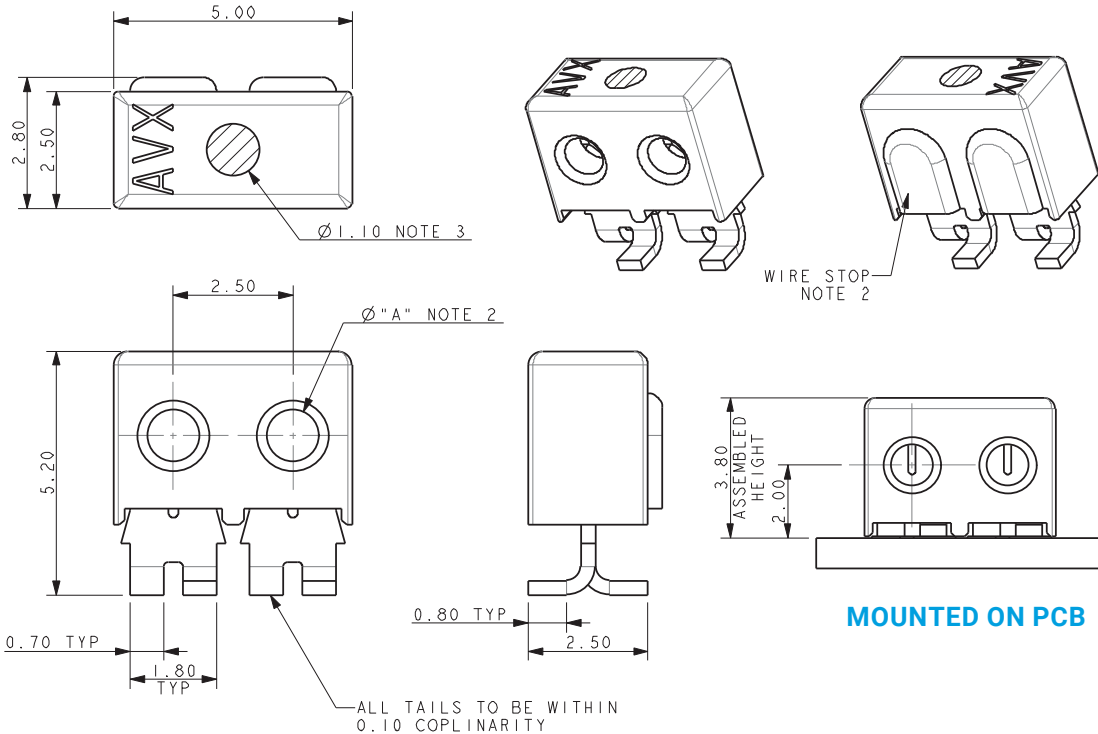

Code	Wire Gauge	Diameter A
701	28AWG	1.10
702	26AWG	1.30

NOTES:

- 2 WAY CONNECTOR FOR IDC WIRE TO BOARD CONNECTION. PRE-ASSEMBLED WIRE STOP CAP.
- WIRE STOP CAP PROTECTS END OF WIRE.
- CONTACT/CAP TO MATCH 26AWG AND 28AWG WIRES. SOLID OR STRANDED CONDUCTOR. MAXIMUM INSULATOR 1.00 MM DIAMETER.
- FLAT FACE ON TOP OF CAP TO AID PICK AND PLACE ASSEMBLY.
- FOR FULL PRODUCT SPECIFICATION ON STANDARD CONNECTORS REFER TO ELCO SPEC 201-01-139. UL COMPONENTS REFER TO ELCO SPEC 201-01-139UL.
- ASSEMBLY PROCEDURE, REFER TO APPLICATION NOTES 201-01-140.
- GENERAL TOLERANCE ± 0.20 UNLESS STATED.
- PACKED IN TAPE AND REEL, QUANTITY PER REEL 1000.
- CONNECTOR OUTLINE.
- CONTACT MATERIAL: TIN PLATED COPPER ALLOY.
- INSULATOR MATERIAL: HIGH TEMPERATURE NYLON, GLASS FILLED, UL94 V-0. COLOR REFER TO PAGE 10.
- FOR UL CODES UL REFERENCE E90723 (US AND CANADA).

PACKING DETAILS

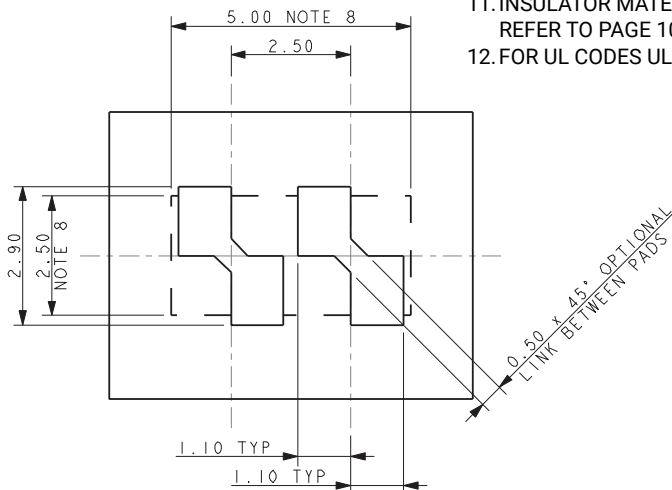

SUGGEST PCB LAYOUT

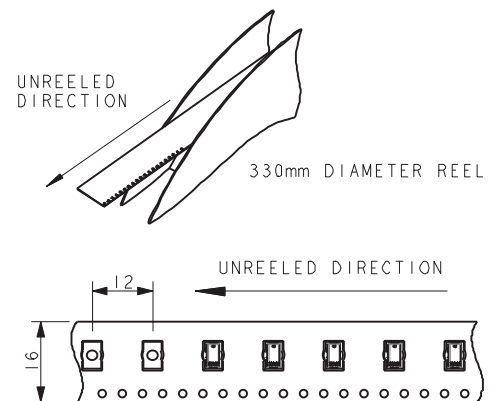

The Important Information/Disclaimer is incorporated in the catalog where these specifications came from or available online at www.avx.com/disclaimer/ by reference and should be reviewed in full before placing any order.

090721

CAPPED IDC 26-28 AWG: 9175-700

3 Position - Wire Stop

26-28 AWG 3 WAY IDC CONNECTOR WIRE STOP CAPPED IDC

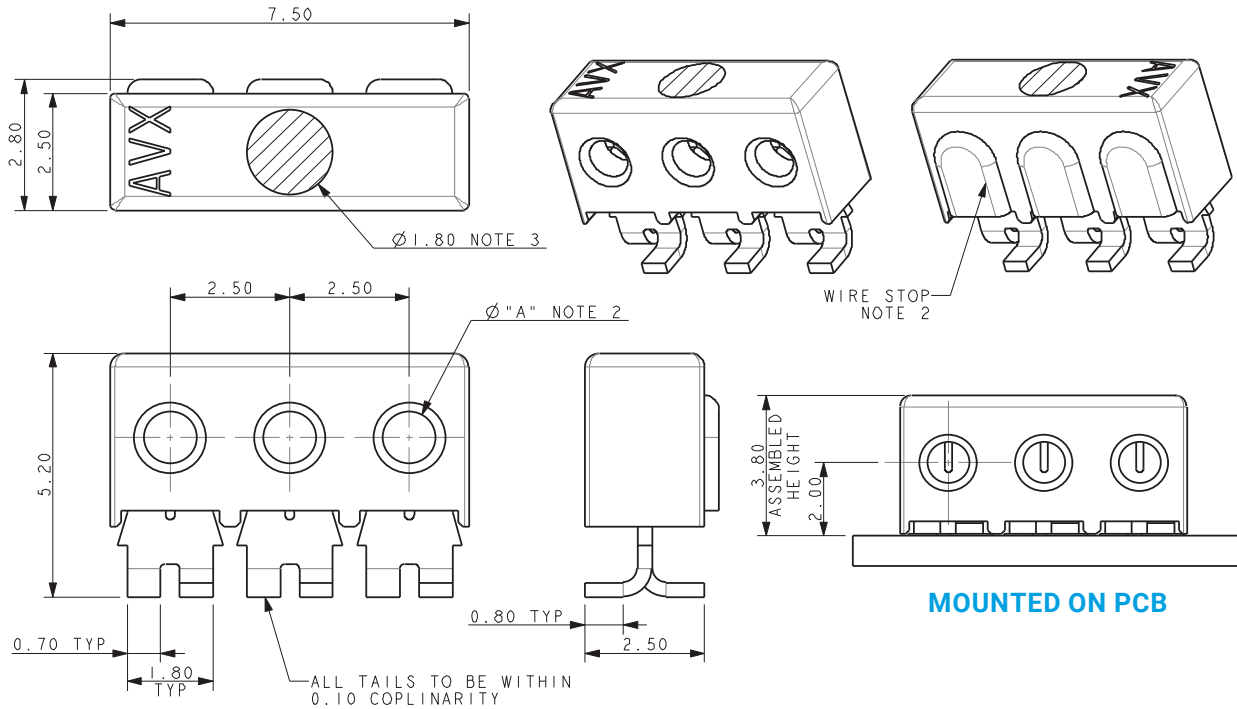

MOUNTED ON PCB

NOTES:

- 3 WAY CONNECTOR FOR IDC WIRE TO BOARD CONNECTION. PRE-ASSEMBLED WIRE STOP CAP.
- WIRE STOP CAP PROTECTS END OF WIRE.
- CONTACT/CAP TO MATCH 26AWG AND 28AWG WIRES. SOLID OR STRANDED CONDUCTOR. MAXIMUM INSULATOR 1.00 MM DIAMETER.
- FLAT FACE ON TOP OF CAP TO AID PICK AND PLACE ASSEMBLY.
- FOR FULL PRODUCT SPECIFICATION ON STANDARD CONNECTORS REFER TO ELCO SPEC 201-01-139. UL COMPONENTS REFER TO ELCO SPEC 201-01-139UL.
- ASSEMBLY PROCEDURE, REFER TO APPLICATION NOTES 201-01-140.
- GENERAL TOLERANCE ± 0.20 UNLESS STATED.
- PACKED IN TAPE AND REEL, QUANTITY PER REEL 1000.
- CONNECTOR OUTLINE.
- CONTACT MATERIAL: TIN PLATED COPPER ALLOY.
- INSULATOR MATERIAL: HIGH TEMPERATURE NYLON, GLASS FILLED, UL94 V-0. COLOR REFER TO PAGE 10.
- FOR UL CODES UL REFERENCE E90723 (US AND CANADA).

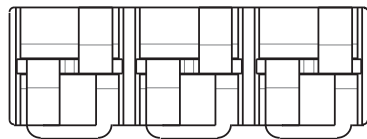

Code	Wire Gauge	Diameter A
701	28AWG	1.10
702	26AWG	1.30

PACKING DETAILS

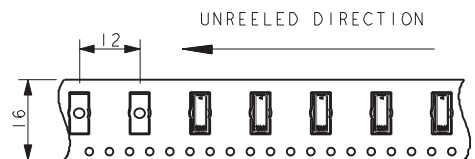
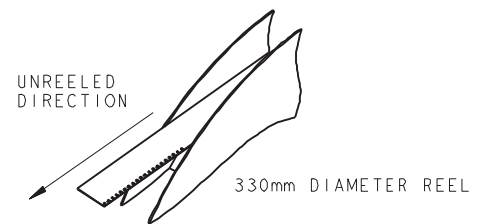

QUANTITY PER REEL 1000

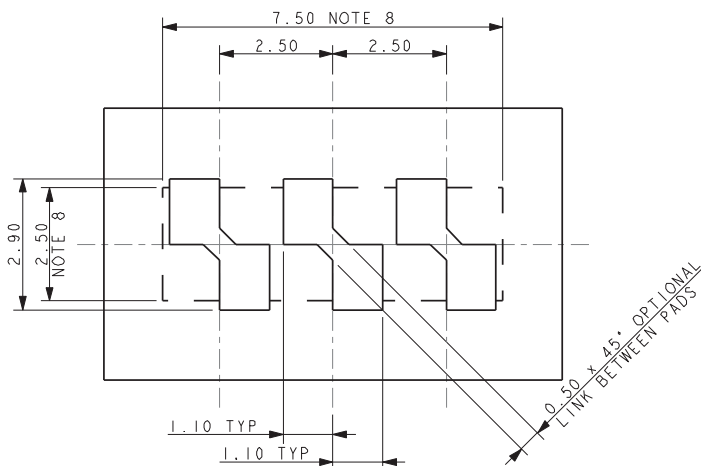

SUGGEST PCB LAYOUT

CAPPED IDC 26-28 AWG: 9175-700

Assembly - Through Wire and Wire Stop

26-28 AWG ASSEMBLED CAPPED IDC CONNECTORS

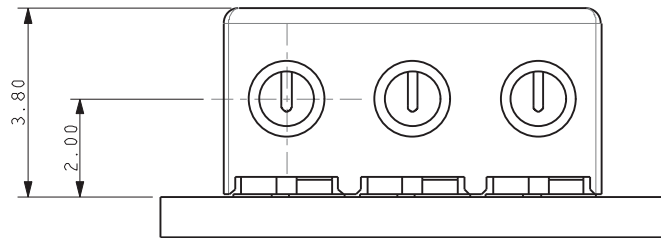

MOUNTED ON PCB

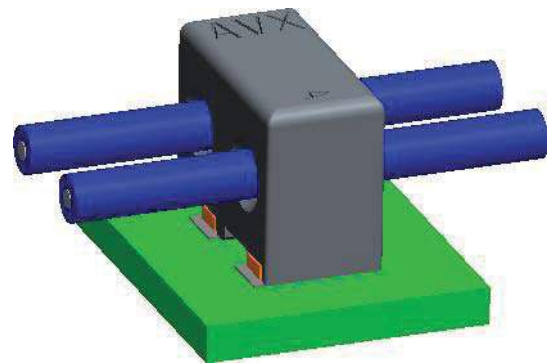
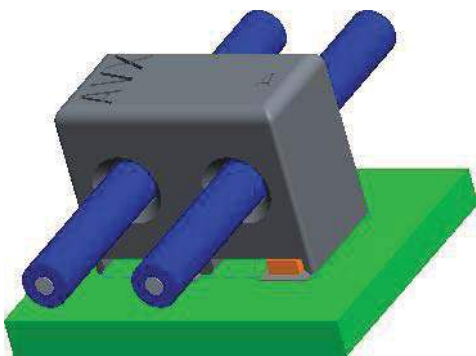

TYPICAL THROUGH WIRE ASSEMBLY

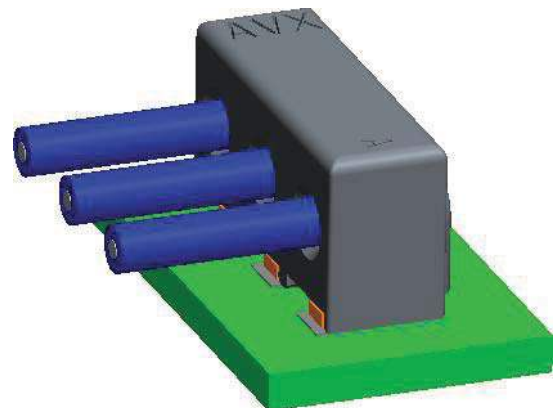
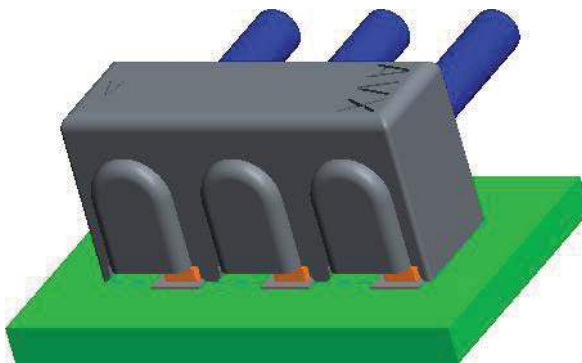

TYPICAL WIRE STOP ASSEMBLY