

LOC	DIST	REVISIONS			
P	LTR	DESCRIPTION	DATE	DWN	APVD
ES	-				
	A	RELEASED PER ECR-10-017956	29AUG2010	S.W	S.Y
	B	RELEASED PER ECR-13-014891	22SEP2010	E.L	WK.H

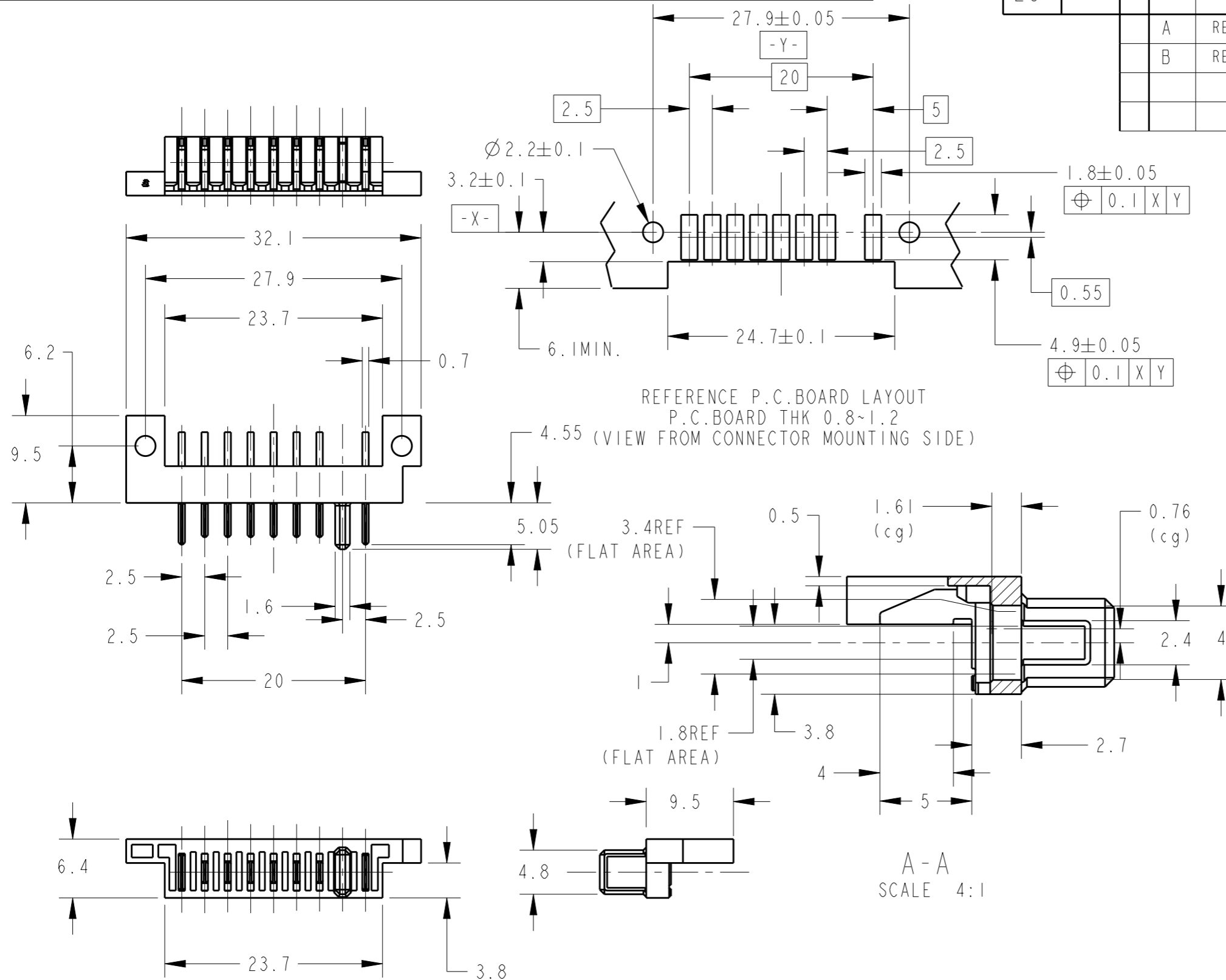

REFERENCE P.C. BOARD LAYOUT
 P.C. BOARD THK 0.8~1.2
 4.55 (VIEW FROM CONNECTOR MOUNTING SIDE)

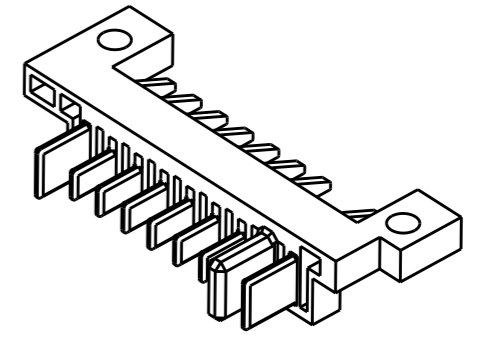

- 1 MATERIAL
 HOUSING: THERMOPLASTIC RESIN
 UL94V-0, BLACK
 CONTACT: COPPER ALLOY
- 2 FINISH
 CONTACT: Ni ALL OVER UNDER PL.
 GOLD PL. AT CONTACT AREA
 GOLD FLUSH PL. AT LEAD AREA

1932677-1/2: AS SHOWN

<small>THIS DRAWING IS A CONTROLLED DOCUMENT FOR TYCO ELECTRONICS CORPORATION IT IS SUBJECT TO CHANGE AND THE CONTROLLING ENGINEERING ORGANIZATION SHOULD BE CONTACTED FOR THE LATEST REVISION.</small>		DWN 29JUN2010 Sabrina Wang CHK 29JUN2010 Wenke He APVD 29JUN2010 Steven Yao		Tyco Electronics Shanghai, P.R.China, 200233	
DIMENSIONS: mm		TOLERANCES UNLESS OTHERWISE SPECIFIED: ±0.3 0 PLC ± 1 PLC ±0.3 2 PLC ±0.10 3 PLC ±0.001 4 PLC ±0.0001 ANGLES ±3°		NAME PLUG ASSEMBLY OFFSET TYPE 2.5mm PITCH BATTERY CONNECTOR	
MATERIAL 1		FINISH 2		PRODUCT SPEC - APPLICATION SPEC - WEIGHT -	
CUSTOMER DRAWING				SIZE A3 CAGE CODE 00779 DRAWING NO. C-1932677	RESTRICTED TO - SCALE 2:1 SHEET 1 OF 1 REV B