

OPTIONAL TERMINALS FOR PUSH ON CONNECTIONS (.032 X .250) [0.8 X 6.4] SUPPLIED

MARK MOTOR SPEED AS REQ'D

STANDOFFS TAPPED 1/2-13 X .50 (12.7) DEEP FOR MTG. BOLTS (4) PLACES

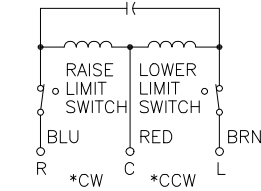
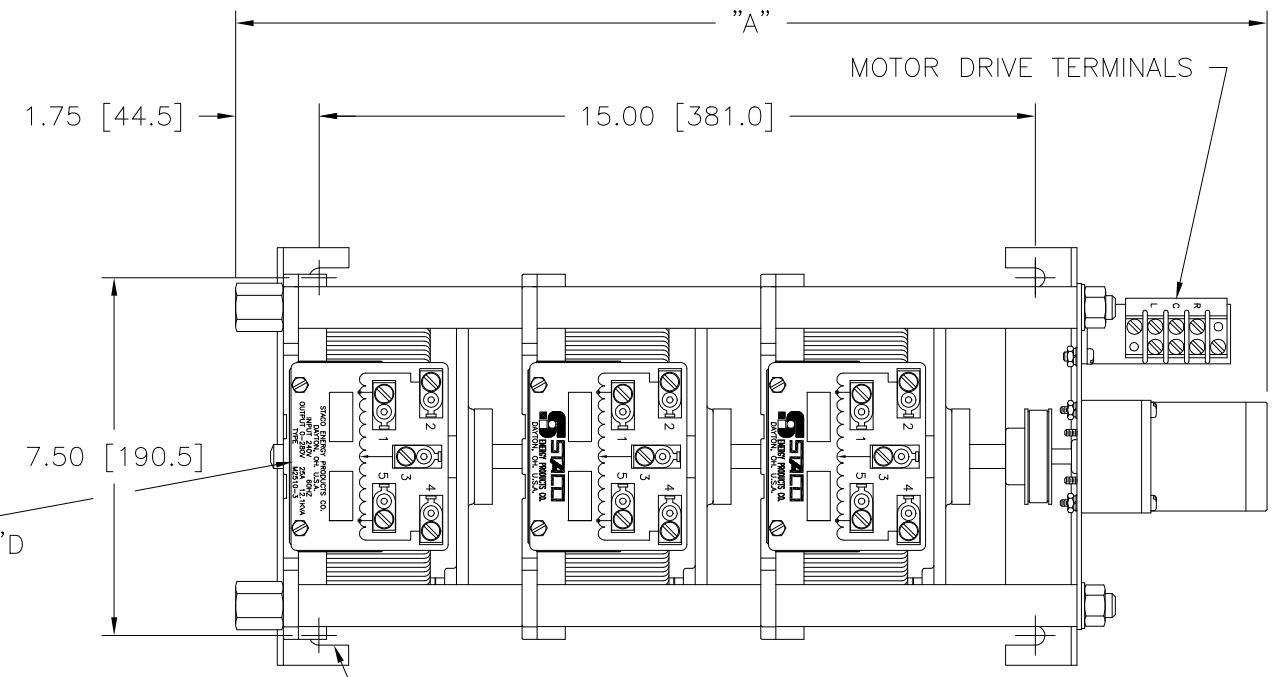

MOTOR CIRCUIT  
 120V, 50/60 HZ  
 \* ROTATION AS VIEWED FROM MOTOR END  
 MOTOR SPEED: SEE CHART

SPEED (SECONDS)	MODEL NUMBER	DIM "A"
5	5M2510-3 +	21.23 [539.2]
15	15M2510-3 +	21.23 [539.2]
30	30M2510-3 +	21.62 [549.1]
60	60M2510-3 +	21.62 [549.1]

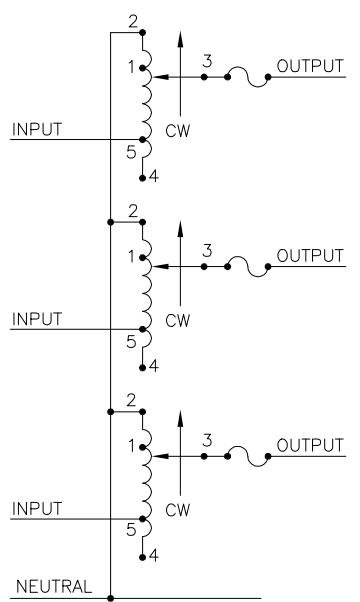

SCHEMATIC THREE PHASE WYE FUSES RECOMMENDED BUT NOT SUPPLIED

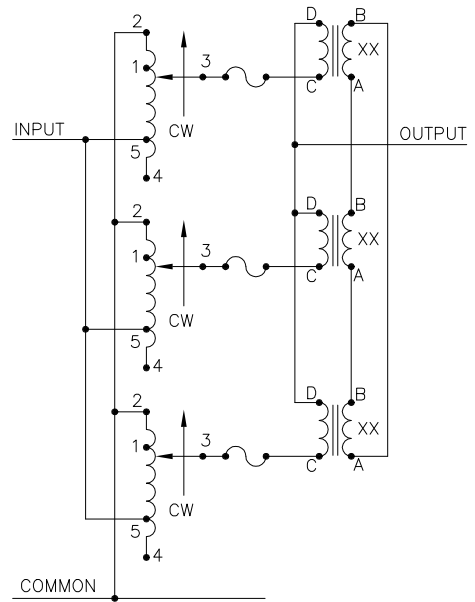

SCHEMATIC SINGLE PHASE PARALLEL FUSES RECOMMENDED BUT NOT SUPPLIED

NOTES:

- ⌘ IF GANGED UNITS ARE USED IN A SYSTEM THAT ORDINARILY HAS A COMMON NEUTRAL OR GROUND BETWEEN SOURCE AND LOAD, THE NEUTRAL OR GROUND MUST BE CONNECTED TO THE COMMON TERMINALS OF THE VARIABLE TRANSFORMER ASSEMBLY. IF THE SYSTEM HAS NO NEUTRAL, THE LOAD MUST BE BALANCED OR THE TRANSFORMER WILL BE DAMAGED.
- XX REQUIRES THREE 51LAC PARALLELING CHOKES.
- JUMPER PROVIDED IN STANDARD COMMON POSITION AND SHOULD BE MOVED OR REMOVED AS REQUIRED.
- + MOTOR DRIVEN UNITS USE TERMINAL CONNECTIONS FOR CCW INCREASING VOLTAGE, AS VIEWED FROM THE BASE END.
- ++ LINE TO LINE VOLTAGE.

WIRING	INPUT		OUTPUT				SHAFT ROTATION TO INCREASE VOLTAGE	TERMINAL CONNECTIONS FOR INCREASING VOLTAGE AS VIEWED FROM BASE END			
	VOLTS	HERTZ	VOLTS	CONSTANT CURRENT LOAD		CONSTANT IMPEDANCE LOAD		INPUT	JUMPER	OUTPUT	
				MAX. AMPS	MAX. KVA	MAX. AMPS					MAX. KVA
THREE PHASE WYE $\pi$	240	50/60	0-240	25	10.40	30	12.5	CW	2-2-2	4-4-4	3-3-3
							CCW	4-4-4	4-4-4	3-3-3	
			0-280	25	12.10	—	—	CW	1-1-1	4-4-4	3-3-3
							CCW	5-5-5	4-4-4	3-3-3	
SINGLE PHASE PARALLEL XX	120	50/60	0-120	75	9.00	90	10.8	CW	2-2-2	4-4-4	—
								CCW	2-2-2	4-4-4	—
			0-140	75	10.50	—	—	CW	1-1-1	4-4-4	—
							CCW	2-2-2	5-5-5	—	

UNLESS OTHERWISE SPECIFIED, TOLERANCE IS \* DECIMALS .005, HOLES .01, ANGLES 1°, DRAFT 1-1/2°. UNITS IN [mm].

MATERIAL: ALL DIMENSIONS APPLY AFTER PLATING.

TITLE: SPEC. CONTROL DRAWING MOTORIZED VARIABLE XFMR. TYPE: M2510-3

STACO ENERGY PRODUCTS CO. A COMPONENTS CORPORATION OF AMERICA COMPANY DAYTON, OHIO U.S.A.

DRAWN BY: TIM RAU, DATE: 8/19/99, DO NOT SCALE DWG., CUSTOMER APPROVAL: [ ] DATE: [ ]

CHECKER: [ ], DATE: [ ], WEIGHT APPROX. 78 LBS., CODE IDENT. NO. 83008, DWG. NO. 031-5165

ENGINEER: [ ], DATE: [ ], SCALE: .5=1, SHEET 1 OF 1, DWG. NO. 031-5165