

ISL32610E, ISL32611E, ISL32612E

±16.5kV ESD Protected, 1.8V, Micro Power, +125°C, 1/8 Unit Load, RS-485/RS-422 Differential Receivers

FN7869
Rev.2.00
Sep 26, 2019

The [ISL32610E](#), [ISL32611E](#), [ISL32612E](#) are ±16.5kV IEC61000 ESD protected, fractional unit load (UL), 1.8V powered, single differential receivers (Rx) for balanced data communication using the RS-485 and RS-422 standards. With their 85µA supply currents, the receivers are optimized for low power applications, and deliver the lowest supply currents of any available single Rx IC (see [Figure 1](#)).

To improve performance in low data rate applications with slow signal transitions, these Rx feature symmetrical switching points (±200mV) and increased hysteresis. The symmetrical switching points eliminate the duty cycle distortion introduced by full-failsafe type receivers (see [Figure 2](#)), while the larger hysteresis increases noise immunity.

The receivers present a 1/8 unit load to the data bus, which allows up to 256 devices on the network for large node count systems (for example, process automation, remote meter reading systems). The ISL32611E/ISL32612E Rx output is tri-statable using the \overline{RE}/RE input.

The receiver inputs feature a failsafe-if-open design, which ensures a logic high Rx output if Rx inputs are floating. Data rates up to 256kbps are achievable with this device at $V_{CC} = 1.8V$.

See [Table 1](#) for a summary of each device's features. For a companion 1.8V differential transmitter in a SOT-23 package, reference the [ISL32613E](#) datasheet.

Related Literature

For a full list of related documents, visit our website:

- [ISL32610E](#), [ISL32611E](#), and [ISL32612E](#) device pages

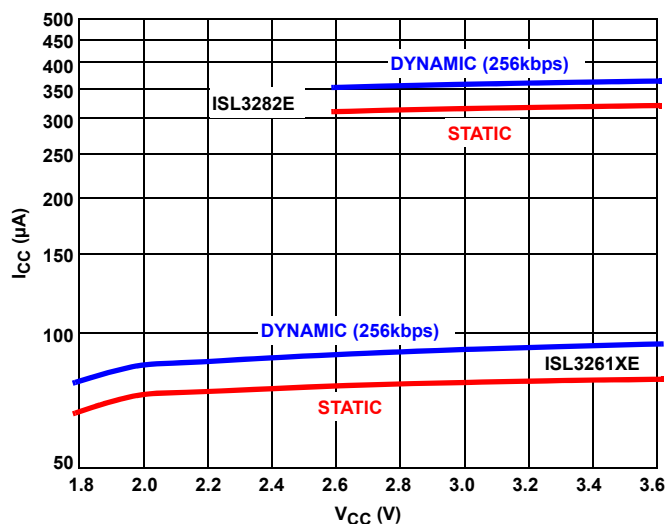

FIGURE 1. ISL3261XE REDUCES OPERATING I_{CC} BY A FACTOR OF 4 FROM PREVIOUS GENERATION RECEIVER ICs, AND OPERATES WITH SUPPLY VOLTAGES AS LOW AS 1.8V

Features

- Wide Supply Voltage Range 1.8V to 3.6V
- Ultra Low Quiescent Supply Current 110µA (maximum)
- IEC61000 ESD Protection on RS-485 Bus Pins ±16.5kV
- Class 3 ESD Level on all Other Pins >8kV HBM
- Symmetrical Switching Thresholds for Less Duty Cycle Distortion (see [Figure 2](#))
- Larger Hysteresis for Improved Noise Immunity 70mV
- Data Rates up to 256kbps (1.8V) or 500kbps (3.3V)
- 1/8 Unit Load Allows up to 256 Devices on the RS-485 Bus
- Specified for +125°C Operation
- Three-State Rx Output Available
- 5V tolerant logic inputs
- Pb-Free (RoHS Compliant)

Applications

- Industrial/Process Control Networks, Factory Automation
- High Node Count Networks
- Space Constrained Systems
- Building Environmental Control Systems

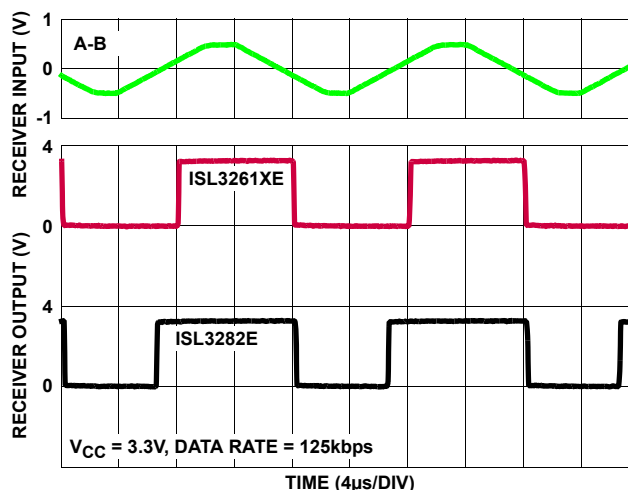

FIGURE 2. COMPARED WITH A FULL-FAILSAFE RECEIVER, THE SYMMETRICAL RX THRESHOLDS OF THE ISL3261XE DELIVER LESS OUTPUT DUTY CYCLE DISTORTION WHEN DRIVEN WITH SLOW INPUT SIGNALS

Typical Operating Circuits

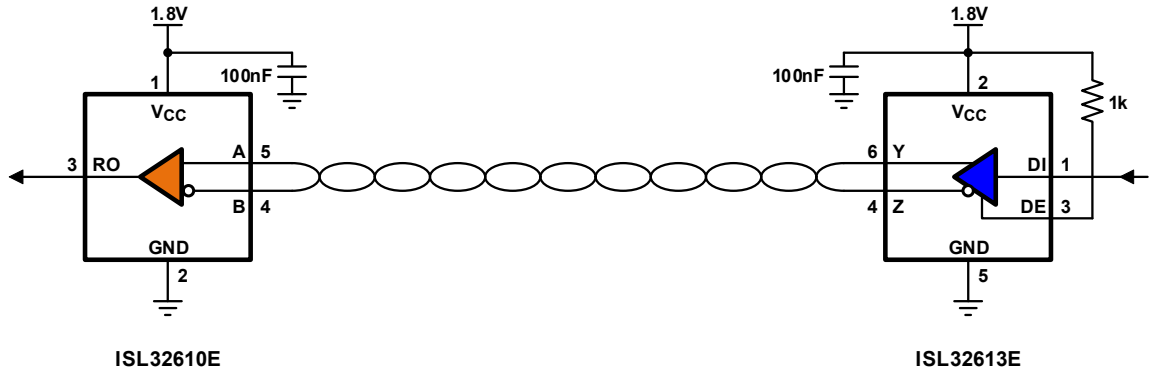

FIGURE 3. POINT-TO-POINT LINK WITH FIXED ENABLE-PINS

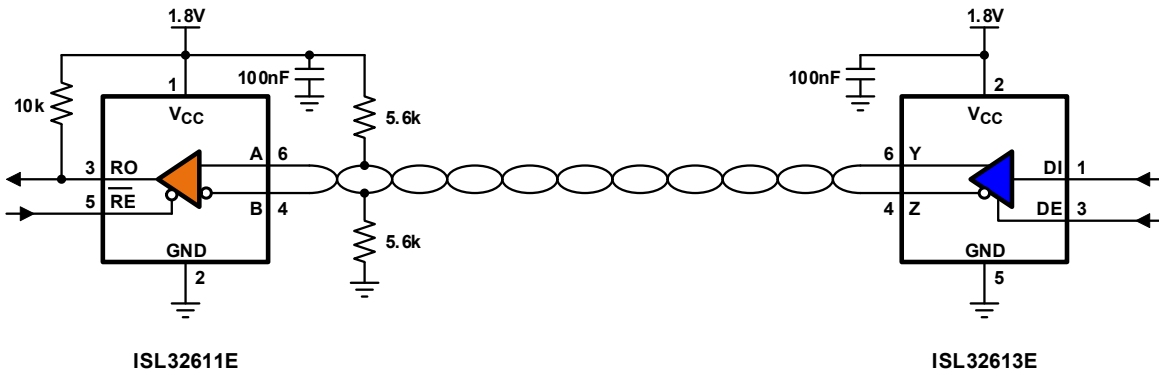

FIGURE 4. POINT-TO-POINT LINK WITH PROGRAMMABLE ENABLE-PINS

Ordering Information

PART NUMBER (Notes 2, 3, 4)	PART MARKING	TEMP. RANGE (°C)	TAPE AND REEL (Units) (Note 1)	PACKAGE (Pb-Free)	PKG. DWG. #
ISL32610EFHZ-T	610F	-40 to +125	3k	5 Ld SOT-23	P5.064
ISL32610EFHZ-T7A	610F	-40 to +125	250	5 Ld SOT-23	P5.064
ISL32611EFHZ-T	611F	-40 to +125	3k	6 Ld SOT-23	P6.064
ISL32611EFHZ-T7A	611F	-40 to +125	250	6 Ld SOT-23	P6.064
ISL32612EFHZ-T	612F	-40 to +125	3k	6 Ld SOT-23	P6.064
ISL32612EFHZ-T7A	612F	-40 to +125	250	6 Ld SOT-23	P6.064

NOTES:

1. See [TB347](#) for details about reel specifications.
2. These Pb-free plastic packaged products employ special Pb-free material sets, molding compounds/die attach materials, and 100% matte tin plate plus anneal (e3 termination finish, which is RoHS compliant and compatible with both SnPb and Pb-free soldering operations). Pb-free products are MSL classified at Pb-free peak reflow temperatures that meet or exceed the Pb-free requirements of IPC/JEDEC J STD-020.
3. For Moisture Sensitivity Level (MSL), see [ISL32610E](#), [ISL32611E](#), [ISL32612E](#).device pages. For more information about MSL, see [TB363](#).
4. The part marking is located on the bottom of the part.

TABLE 1. SUMMARY OF FEATURES

PART NUMBER	CONFIGURATION	NUMBER OF DEVICES ALLOWED ON BUS	1.8V, 3.3V DATA RATE (kbps)	Rx ENABLE?	QUIESCENT I _{CC} (µA)	LOW POWER SHUTDOWN?	PIN COUNT
ISL32610E	Rx Only	256	256, 500	No	85	No	5
ISL32611E	Rx Only	256	256, 500	Yes, Active Low	85	Yes	6
ISL32612E	Rx Only	256	256, 500	Yes, Active High	85	Yes	6

Pin Configurations

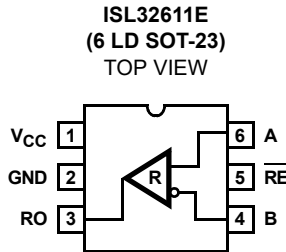
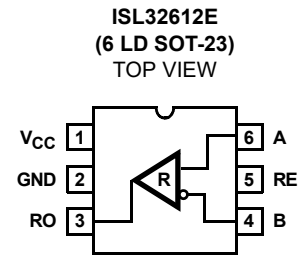
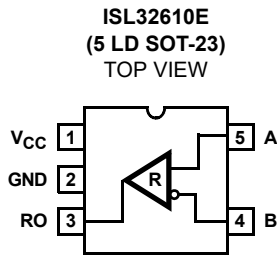

Truth Table

RECEIVING		
INPUTS		OUTPUT
\overline{RE} / RE (Note 12)	A-B	RO
0 / 1	$\geq +0.2V$	1
0 / 1	$\leq -0.2V$	0
0 / 1	Inputs Open	1
1 / 0	X	High-Z (Note 5)

NOTE:

5. Low Power Shutdown Mode (Note 10, except for the ISL32610E)

Pin Descriptions

PIN NAME	PIN NUMBER			FUNCTION
	ISL32610E	ISL32611E	ISL32612E	
V _{CC}	1	1	1	System power supply input (1.8V to 3.6V).
GND	2	2	2	Ground connection.
RO	3	3	3	Receiver output: If A > B by at least 0.2V, RO is high; if A < B by 0.2V or more, RO is low; RO = High if A and B are unconnected (floating).
B	4	4	4	$\pm 16.5kV$ IEC61000 ESD protected, inverting differential receiver input.
\overline{RE}	-	5	-	Receiver output enable. RO is enabled when \overline{RE} is low; RO is high impedance when \overline{RE} is high. If the enable function isn't needed, connect \overline{RE} to GND. \overline{RE} is internally pulled low.
RE	-	-	5	Receiver output enable. RO is enabled when RE is high; RO is high impedance when RE is low. If the enable function is not needed, connect RE to V _{CC} through a 1k Ω or greater resistor. RE is internally pulled high.
A	5	6	6	$\pm 16.5kV$ IEC61000 ESD Protected, noninverting differential receiver input.

Absolute Maximum Ratings

V _{CC} to Ground	7V
Input Voltages	
RE, RE	-0.3V to 7V
A, B	-8V to +12.5V
Output Voltages	
RO	-0.3V to (V _{CC} + 0.3V)
ESD Rating	See "ESD PERFORMANCE" on page 6
Latch-Up (per JEDEC78, Level 2, Class A)	+125°C

Thermal Information

Thermal Resistance (Typical)	θ_{JA} (°C/W)	θ_{JC} (°C/W)
5 Ld SOT-23 Package (Note 6, 7)	190	120
6 Ld SOT-23 Package (Note 6, 7)	177	120
Maximum Junction Temperature (Plastic Package)	+150°C	
Storage Temperature Range	-65°C to +150°C	
Pb-Free Reflow Profile	see TB493	

Recommended Operating Conditions

Temperature	-40°C to +125°C
Supply Voltage	1.8V to 3.3V
Common-Mode Input Voltage	
V _{CC} = 1.8V	-2V to +2V
V _{CC} = 3.3V	-7V to +12V

CAUTION: Do not operate at or near the maximum ratings listed for extended periods of time. Exposure to such conditions can adversely impact product reliability and result in failures not covered by warranty.

NOTES:

- θ_{JA} is measured with the component mounted on a high-effective thermal conductivity test board in free air. See TB379 for details.
- For θ_{JC} , the case temperature location is taken at the package top center.

Electrical Specifications Test Conditions: V_{CC} = 1.8V; typical values are at V_{CC} = 1.8V, T_A = +25°C; unless otherwise specified. **Boldface limits apply across the operating temperature range, -40°C to +125°C.** (Note 9)

PARAMETER	SYMBOL	TEST CONDITIONS	TEMP (°C)	MIN (Note 8)	TYP	MAX (Note 8)	UNIT	
DC CHARACTERISTICS								
Logic Input High Voltage (Note 12)	V _{IH}	RE, RE	V _{CC} = 1.8V	Full	1.2	-	V	
			3V ≤ V _{CC} ≤ 3.6V	Full	2	-	V	
Logic Input Low Voltage (Note 12)	V _{IL}	RE, RE	V _{CC} = 1.8V	Full	-	0.45	V	
			3V ≤ V _{CC} ≤ 3.6V	Full	-	0.8	V	
Logic Input Current (Note 12)	I _{IN1}	RE, RE	V _{CC} = 1.8V	Full	-6	6	μA	
			V _{CC} ≤ 3.6V	Full	-12	12	μA	
Input Current (A, B) (Note 11)	I _{IN2}	V _{CC} = 0V or 1.8V	V _{IN} = 2V	Full	-	60	μA	
			V _{IN} = -2V	Full	-60	-	μA	
		V _{CC} = 0V or 3.6V	V _{IN} = 12V	Full	-	125	μA	
			V _{IN} = -7V	Full	-100	-	μA	
Receiver Differential Threshold Voltage	V _{TH}	-2V ≤ V _{CM} ≤ 2V	V _{CC} = 1.8V	Full	-0.2	0.2	V	
		-7V ≤ V _{CM} ≤ 12V	3V ≤ V _{CC} ≤ 3.6V	Full	-0.2	0.2	V	
Receiver Input Hysteresis	ΔV _{TH}	V _{CM} = 0V	V _{CC} = 1.8V	Full	-	70	mV	
			3V ≤ V _{CC} ≤ 3.6V	Full	-	70	mV	
Receiver Output High Voltage	V _{OH}	I _O = -1mA, V _{ID} = 200mV	Full	V_{CC} - 0.4	-	-	V	
Receiver Output Low Voltage	V _{OL}	I _O = 2mA, V _{ID} = -200mV	Full	-	-	0.4	V	
Three-State (High Impedance) Receiver Output Current (Note 12)	I _{OZR}	0V ≤ V _O ≤ V _{CC}	Full	-1	-	1	μA	
Receiver Short-Circuit Current	I _{OSR}	0V ≤ V _O ≤ V _{CC}	Full	-	-	30	mA	
No-Load Supply Current	I _{CC}	RE = 0V or RE = V _{CC}	V _{CC} = 1.8V	Full	-	85	μA	
			3V ≤ V _{CC} ≤ 3.6V	Full	-	135	μA	
Shutdown Supply Current (Note 10, 12)	I _{SHDN}	ISL32611, RE = V _{CC} , V _{CC} ≥ 1.8V	V _{CC} = 1.8V	Full	-	2	μA	
			ISL32612, RE = 0V	V _{CC} = 1.8V	Full	-	7	μA
				V _{CC} ≤ 3.6V	Full	-	14	μA

Electrical Specifications Test Conditions: $V_{CC} = 1.8V$; typical values are at $V_{CC} = 1.8V, T_A = +25^\circ C$; unless otherwise specified. **Boldface limits apply across the operating temperature range, $-40^\circ C$ to $+125^\circ C$.** (Note 9) (Continued)

PARAMETER	SYMBOL	TEST CONDITIONS	TEMP (°C)	MIN (Note 8)	TYP	MAX (Note 8)	UNIT
SWITCHING CHARACTERISTICS							
Maximum Data Rate	f_{MAX}	$V_{ID} = \pm 1V, V_{CM} = 0V,$ (Figure 5)	$V_{CC} = 1.8V$	Full	256	-	kbps
			$3V \leq V_{CC} \leq 3.6V$	Full	500	-	kbps
Receiver Input to Output Delay	t_{PLH}, t_{PHL}	(Figure 5)	$V_{CC} = 1.8V$	Full	-	210	1000 ns
			$V_{CC} = 3.3V$	25	-	200	-
Receiver Skew $t_{PLH} - t_{PHL}$	t_{SKD}	(Figure 5)	$V_{CC} = 1.8V$	Full	-	3	125 ns
			$V_{CC} = 3.3V$	25	-	6	-
Receiver Enable to Output High	t_{ZH}	$C_L = 15pF, SW = GND,$ (Figure 6, Note 12)	$V_{CC} = 1.8V$	Full	-	1100	4000 ns
			$V_{CC} = 3.3V$	25	-	1500	-
Receiver Enable to Output Low	t_{ZL}	$C_L = 15pF, SW = V_{CC},$ (Figure 6, Note 12)	$V_{CC} = 1.8V$	Full	-	1100	4000 ns
			$V_{CC} = 3.3V$	25	-	1500	-
Receiver Disable from Output High	t_{HZ}	$C_L = 15pF, SW = GND,$ (Figure 6, Note 12)	$V_{CC} = 1.8V$	Full	-	15	75 ns
			$V_{CC} = 3.3V$	25	-	6	-
Receiver Disable from Output Low	t_{LZ}	$C_L = 15pF, SW = V_{CC},$ (Figure 6, Note 12)	$V_{CC} = 1.8V$	Full	-	15	75 ns
			$V_{CC} = 3.3V$	25	-	6	-
ESD PERFORMANCE							
RS-485 Pins (A, B)		IEC61000-4-2, Air-Gap Discharge Method	25	-	± 16.5	-	kV
		IEC61000-4-2, Contact Discharge Method	25	-	± 9	-	kV
		Human Body Model, From Bus Pins to GND	25	-	± 16.5	-	kV
All Pins		Human Body Model (Tested per JESD22-A114E)	25	-	± 8	-	kV
		Machine Model (Tested per JESD22-A115-A)	25	-	± 400	-	V

NOTES:

8. Compliance to datasheet limits is assured by one or more methods: production test, characterization and/or design.
9. Currents into device pins are positive; currents out of device pins are negative. Voltages are referenced to ground unless otherwise specified.
10. The ISL32611E enters SHDN whenever \overline{RE} switches high, and the ISL32612E enters SHDN whenever RE switches low.
11. Devices meeting these limits are denoted as 1/8 unit load (1/8 UL) transceivers. The RS-485 standard allows up to 32 unit loads on the bus, so there can be 256 1/8 UL devices on a bus.
12. Not applicable to the ISL32610E.

Test Circuits and Waveforms

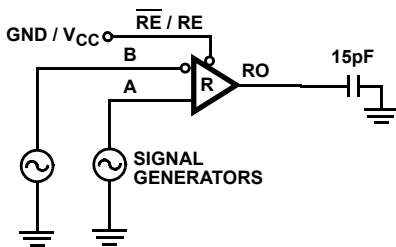

FIGURE 5A. TEST CIRCUIT

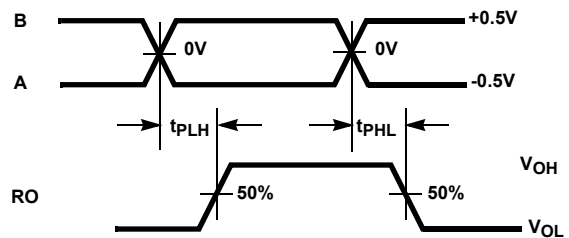
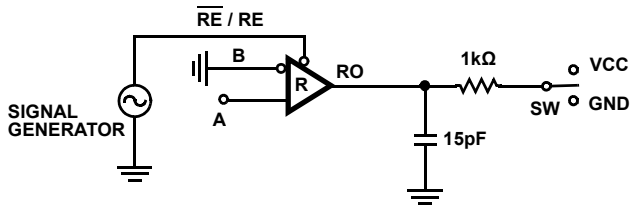

FIGURE 5B. MEASUREMENT POINTS

FIGURE 5. RECEIVER PROPAGATION DELAY AND DATA RATE

Test Circuits and Waveforms (Continued)



PARAMETER	A	SW
t_{HZ}	+1V	GND
t_{LZ}	-1V	V_{CC}
t_{ZH}	+1V	GND
t_{ZL}	-1V	V_{CC}

FIGURE 6A. TEST CIRCUIT

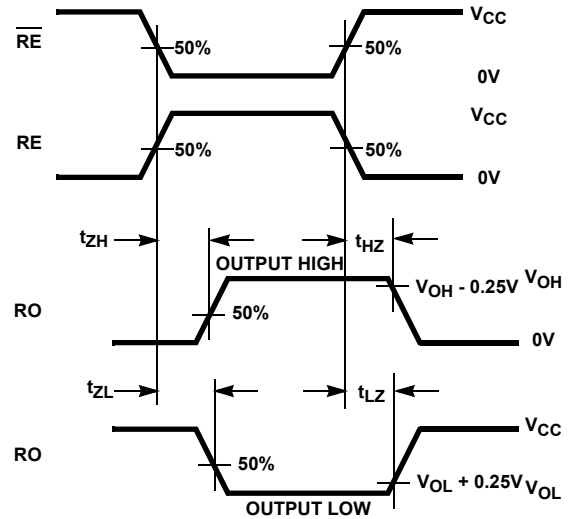

FIGURE 6B. MEASUREMENT POINTS

FIGURE 6. RECEIVER ENABLE AND DISABLE TIMES (EXCLUDING ISL32610E)

Typical Performance Curves $T_A = +25^\circ\text{C}$; Unless Otherwise Specified

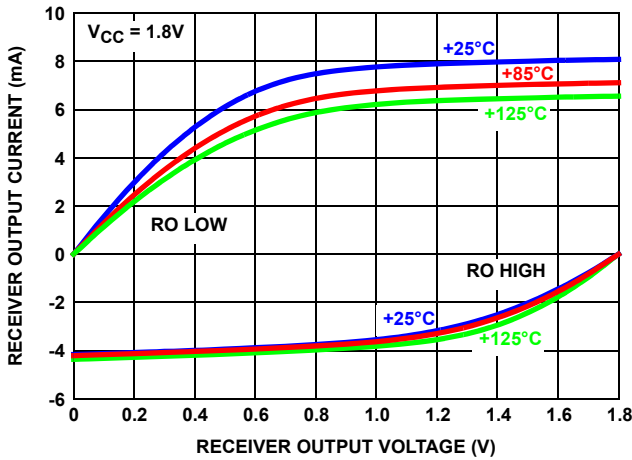

FIGURE 7. RECEIVER OUTPUT CURRENT vs RECEIVER OUTPUT VOLTAGE ($V_{CC} = 1.8\text{V}$)

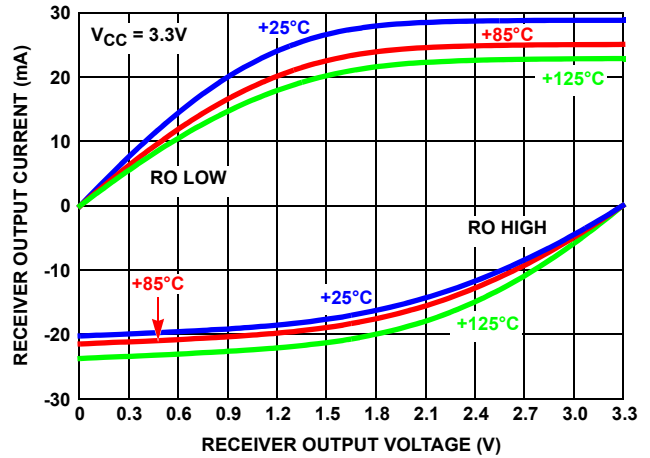

FIGURE 8. RECEIVER OUTPUT CURRENT vs RECEIVER OUTPUT VOLTAGE ($V_{CC} = 3.3\text{V}$)

Typical Performance Curves $T_A = +25^\circ\text{C}$; Unless Otherwise Specified

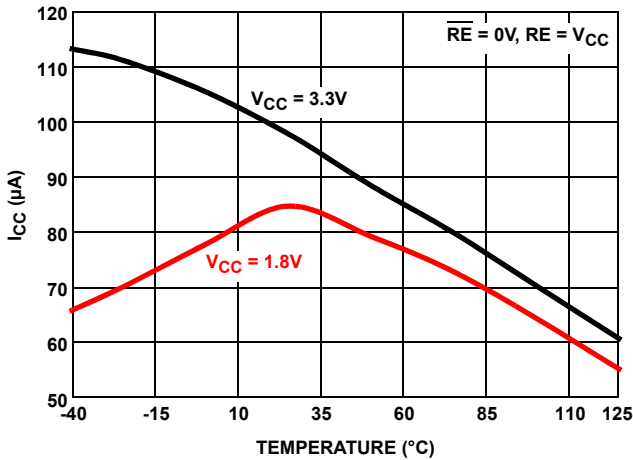

FIGURE 9. STATIC SUPPLY CURRENT vs TEMPERATURE

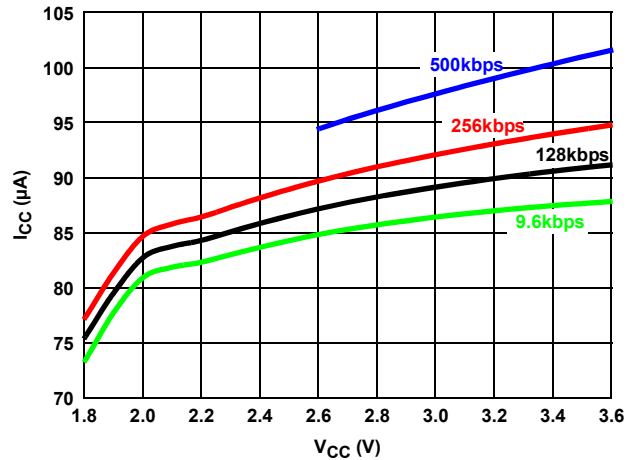

FIGURE 10. DYNAMIC SUPPLY CURRENT vs SUPPLY VOLTAGE AT DIFFERENT DATA RATES

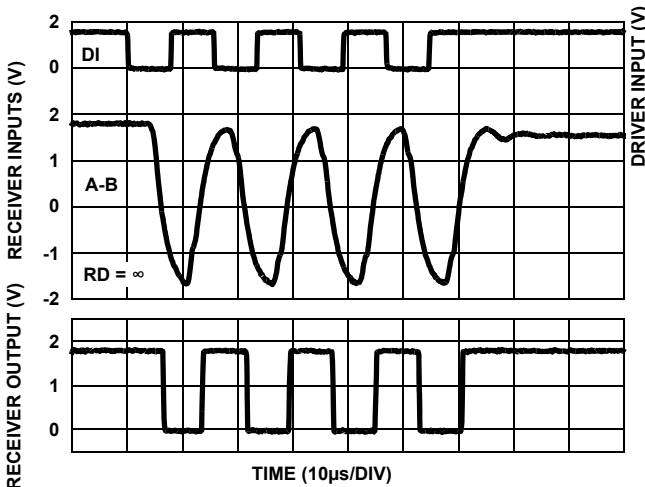

FIGURE 11. ISL32613E AND ISL32611E PERFORMANCE WITH $V_{CC} = 1.8\text{V}$, 128kbps, 2000' (610m) CAT 5 CABLE

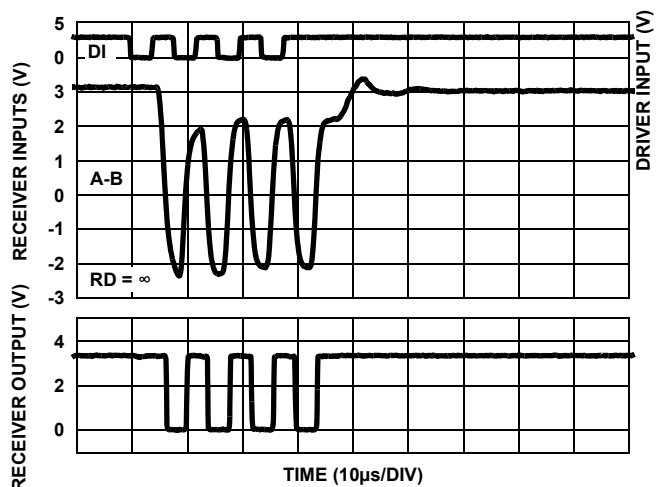

FIGURE 12. ISL32613E AND ISL32611E PERFORMANCE WITH $V_{CC} = 3.3\text{V}$, 256kbps, 3000' (915m) CAT 5 CABLE

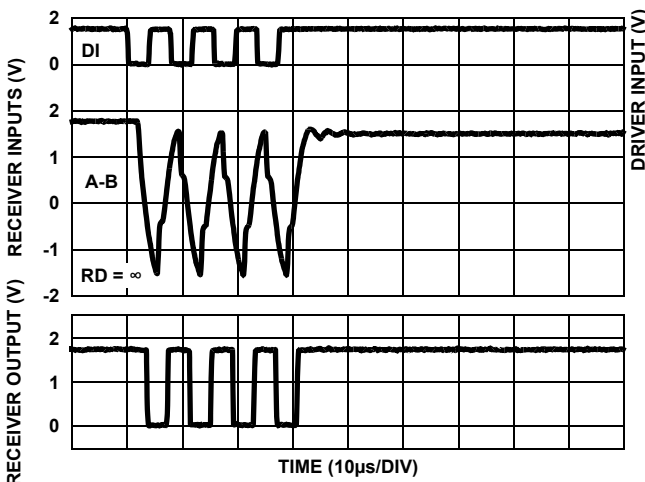

FIGURE 13. ISL32614E AND ISL32611E PERFORMANCE WITH $V_{CC} = 1.8\text{V}$, 256kbps, 1000' (305m) CAT 5 CABLE

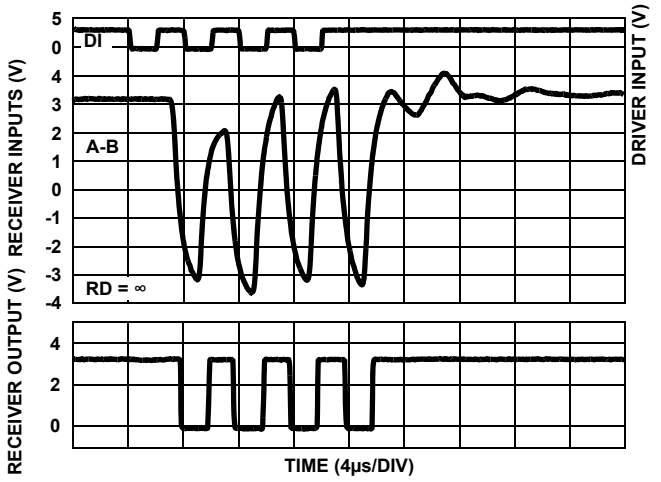

FIGURE 14. ISL32614E AND ISL32611E PERFORMANCE WITH $V_{CC} = 3.3\text{V}$, 500kbps, 2000' (610m) CAT 5 CABLE

Die Characteristics

SUBSTRATE POTENTIAL (POWERED UP) :

GND

PROCESS:

Si Gate BiCMOS

Application Information

Features

The ISL3261xE devices use a differential input receiver for maximum noise immunity and common-mode rejection. Input sensitivity is $\pm 200\text{mV}$, as required by the RS-422 and RS-485 standards. The symmetrical $\pm 200\text{mV}$ switching thresholds of the receivers deliver less duty cycle distortion than similar receivers with a full-failsafe design (for example, skewed low/high input thresholds, (such as $-200\text{mV}/-20\text{mV}$), which increase the high bit width). This distortion is especially noticeable when the Rx is driven by slow input transitions (see [Figure 2](#)).

The symmetrical input thresholds also allow more room for increased input hysteresis, thereby increasing the Rx noise immunity. The 70mV hysteresis of this Rx is twice the amount specified for most full-failsafe devices.

Receiver input resistance of $96\text{k}\Omega$ surpasses the RS-422 specification of $4\text{k}\Omega$, and it is eight times the RS-485 Unit Load (UL) requirement of $12\text{k}\Omega$ minimum. Therefore, the products are known as one-eighth UL receivers, and there can be up to 256 of the devices on a network while still complying with the RS-485 loading specification.

Receiver inputs function with common-mode voltages (CMV) of $\pm 2\text{V}$ with $V_{CC} = 1.8\text{V}$, and with CMVs of -7V to $+12\text{V}$ for $V_{CC} \geq 2.7\text{V}$.

All the receivers include a failsafe-if-open function that guarantees a high level receiver output if the receiver inputs are unconnected (floating). As mentioned previously, the full-failsafe function is not implemented to deliver output duty cycles that better match the input.

Receivers support data rates up to 256kbps ($V_{CC} = 1.8\text{V}$) or 500kbps ($V_{CC} \geq 3\text{V}$), and receiver outputs of the ISL32611E and ISL32612E are three-statable using the active low $\overline{\text{RE}}$ or active high RE input.

Data Rate Recommendations

When coupled with the ISL32613E or ISL32614E 1.8V transmitter ICs, the receivers are useful for networks up to $4000'$ (1220m) long, or for data rates up to 500kbps . For $4000'$ distances with $V_{CC} = 1.8\text{V}$, the ISL32613E can be used with any of these receivers at data rates $\leq 50\text{kbps}$. With $V_{CC} = 3.3\text{V}$, any transmitter/receiver combination operates over $4000'$ at rates up to 128kbps . Shorter networks allow data rates up to 500kbps , as shown in [Figures 11, 12, 13](#) and [14](#).

Network termination resistors are only recommended for networks operating at $V_{CC} \geq 2.7\text{V}$, and using termination resistors may allow for higher data rates.

Low Power Shutdown Mode (ISL32611E and ISL32612E)

The devices use a fraction of the power required by most differential receivers (see [Figure 1](#)), but they also include a shutdown feature that reduces the already low quiescent I_{CC} even further. The ISL32611E and ISL32612E enter shutdown whenever the receiver is disabled ($\text{RE} = \text{GND}$ or $\overline{\text{RE}} = V_{CC}$).

ESD Protection

All pins on the devices include class 3 ($>6\text{kV}$) Human Body Model (HBM) ESD protection structures, but the bus pins (Rx inputs) incorporate advanced structures allowing them to survive ESD events in excess of $\pm 16.5\text{kV}$ HBM and $\pm 16.5\text{kV}$ IEC61000. The bus pins are particularly vulnerable to ESD damage because they typically connect to an exposed port on the exterior of the finished product. Simply touching the port pins, or connecting a cable, can cause an ESD event that might destroy unprotected ICs. The new ESD structures protect the device whether or not it is powered up, and without degrading the common-mode range. This built-in ESD protection eliminates the need for board-level protection structures (e.g., transient suppression diodes), and the associated, undesirable capacitive load they present.

IEC61000-4-2 Testing

The IEC61000 test method applies to finished equipment, rather than to an individual IC. Therefore, the pins most likely to suffer an ESD event are those that are exposed to the outside world (the bus pins in this case), and the IC is tested in its typical application configuration (power applied) rather than testing each pin-to-pin combination. The smaller value current limiting resistor coupled with the larger charge storage capacitor yields a test that is much more severe than the HBM test. The extra ESD protection built into this device's bus pins allows the design of equipment meeting level 4 criteria without the need for additional board-level protection on the I/O port.

AIR-GAP DISCHARGE TEST METHOD

For the air-gap discharge test method, a charged probe tip moves toward the IC pin until the voltage arcs to it. The current waveform delivered to the IC pin depends on approach speed, humidity, temperature, etc., so it is difficult to obtain repeatable results. The A and B pins withstand $\pm 16.5\text{kV}$ air-gap discharges.

CONTACT DISCHARGE TEST METHOD

During the contact discharge test, the probe contacts the tested pin before the probe tip is energized, thereby eliminating the variables associated with the air-gap discharge. The result is a more repeatable and predictable test, but equipment limits prevent testing devices at voltages higher than $\pm 9\text{kV}$. The ISL32610E, ISL32611E, and ISL32612E survive $\pm 9\text{kV}$ contact discharges on the bus pins.

Revision History

The revision history provided is for informational purposes only and is believed to be accurate, but not warranted. Please go to web to make sure you have the latest revision.

DATE	REVISION	CHANGE
Sep 26, 2019	FN7869.2	Updated Figures 3 and 4 and removed note on page2.
Feb 15, 2019	FN7869.1	Added Related Literature section Updated Typical Operating Circuit and added a second. Updated links throughout document. Removed About Intersil section. Updated disclaimer.
Oct 21, 2011	FN7869.0	Initial Release

Package Outline Drawings

For the most recent package outline drawing, see [P5.064](#).

P5.064

5 LEAD SMALL OUTLINE TRANSISTOR PLASTIC PACKAGE

Rev 3, 4/11

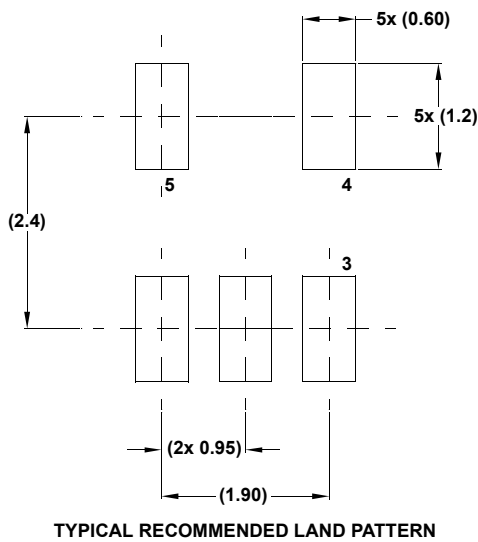
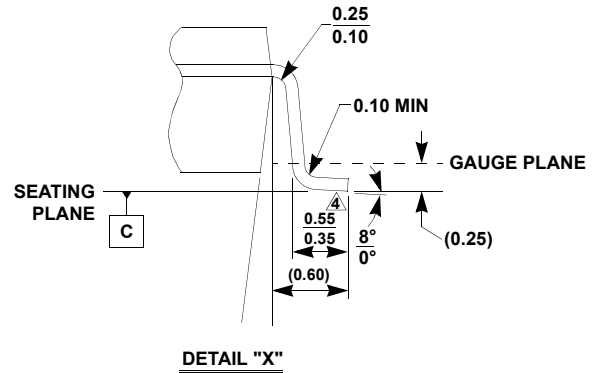
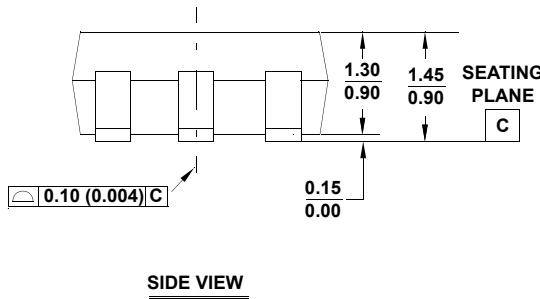
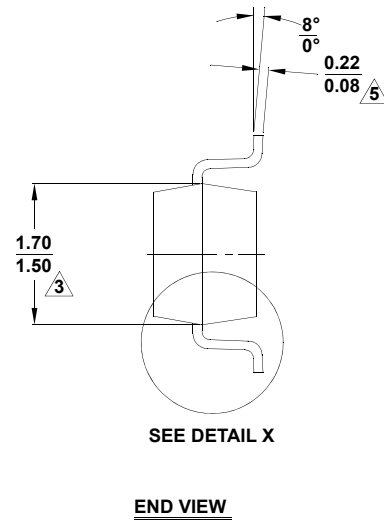
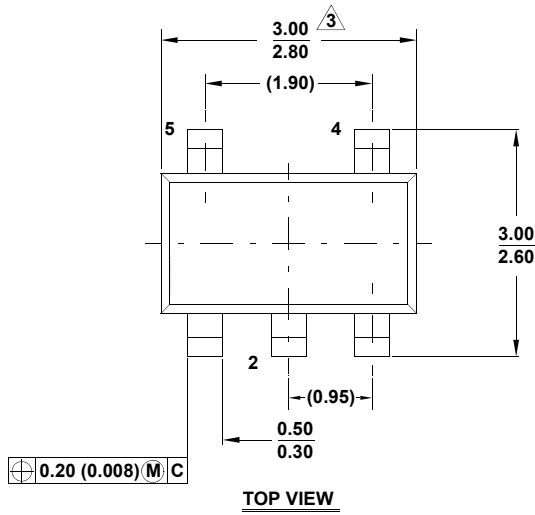

NOTES:

1. Dimensioning and tolerance per ASME Y14.5M-1994.
2. Package conforms to EIAJ SC-74 and JEDEC MO178AA.
3. Package length and width are exclusive of mold flash, protrusions, or gate burrs.
4. Footlength measured at reference to gauge plane.
5. Lead thickness applies to the flat section of the lead between 0.08mm and 0.15mm from the lead tip.
6. Controlling dimension: MILLIMETER.
Dimensions in () for reference only.

P6.064
 6 LEAD SMALL OUTLINE TRANSISTOR PLASTIC PACKAGE
 Rev 4, 2/10

For the most recent package outline drawing, see [P6.064](#).

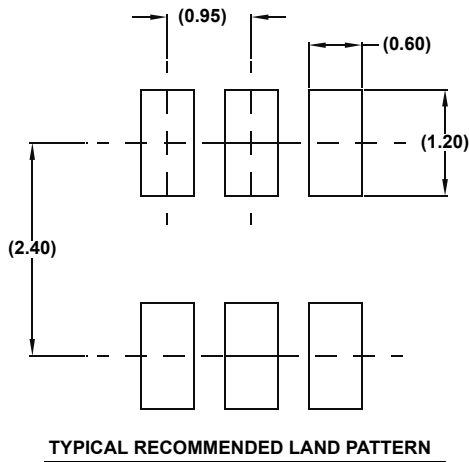
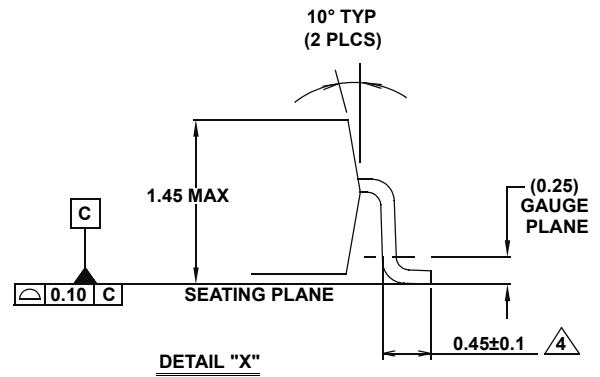
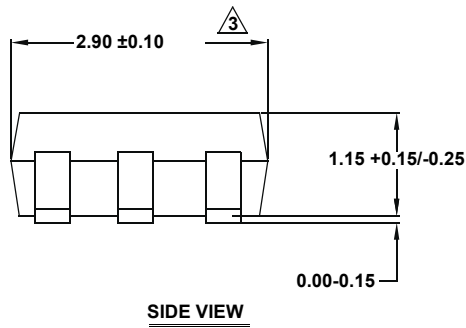
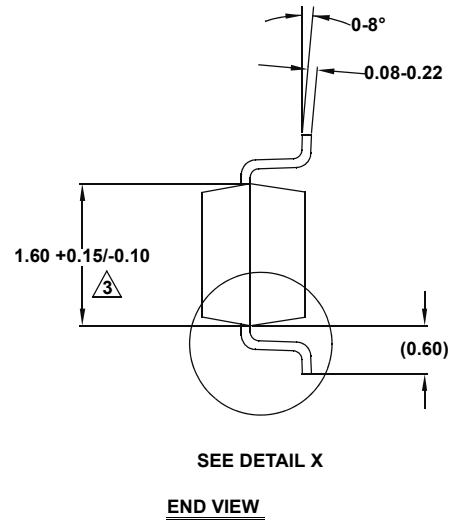
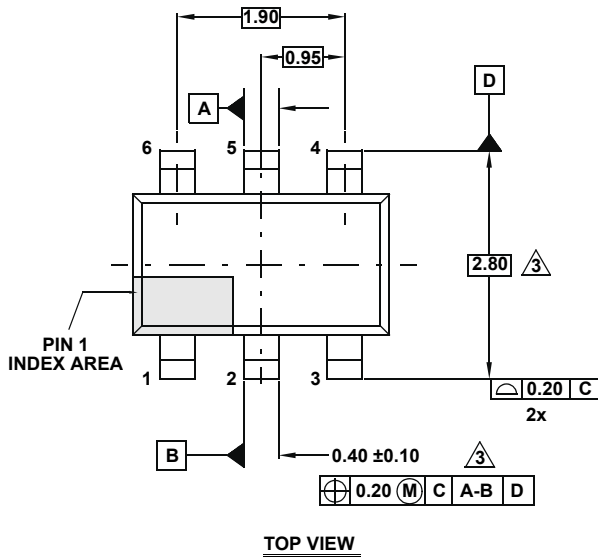

NOTES:

1. Dimensions are in millimeters.
Dimensions in () for Reference Only.
2. Dimensioning and tolerancing conform to ASME Y14.5M-1994.
3. Dimension is exclusive of mold flash, protrusions or gate burrs.
4. Foot length is measured at reference to gauge plane.
5. Package conforms to JEDEC MO-178AB.

Notice

1. Descriptions of circuits, software and other related information in this document are provided only to illustrate the operation of semiconductor products and application examples. You are fully responsible for the incorporation or any other use of the circuits, software, and information in the design of your product or system. Renesas Electronics disclaims any and all liability for any losses and damages incurred by you or third parties arising from the use of these circuits, software, or information.
2. Renesas Electronics hereby expressly disclaims any warranties against and liability for infringement or any other claims involving patents, copyrights, or other intellectual property rights of third parties, by or arising from the use of Renesas Electronics products or technical information described in this document, including but not limited to, the product data, drawings, charts, programs, algorithms, and application examples.
3. No license, express, implied or otherwise, is granted hereby under any patents, copyrights or other intellectual property rights of Renesas Electronics or others.
4. You shall not alter, modify, copy, or reverse engineer any Renesas Electronics product, whether in whole or in part. Renesas Electronics disclaims any and all liability for any losses or damages incurred by you or third parties arising from such alteration, modification, copying or reverse engineering.
5. Renesas Electronics products are classified according to the following two quality grades: "Standard" and "High Quality". The intended applications for each Renesas Electronics product depends on the product's quality grade, as indicated below.
 - "Standard": Computers; office equipment; communications equipment; test and measurement equipment; audio and visual equipment; home electronic appliances; machine tools; personal electronic equipment; industrial robots; etc.
 - "High Quality": Transportation equipment (automobiles, trains, ships, etc.); traffic control (traffic lights); large-scale communication equipment; key financial terminal systems; safety control equipment; etc.Unless expressly designated as a high reliability product or a product for harsh environments in a Renesas Electronics data sheet or other Renesas Electronics document, Renesas Electronics products are not intended or authorized for use in products or systems that may pose a direct threat to human life or bodily injury (artificial life support devices or systems; surgical implantations; etc.), or may cause serious property damage (space system; undersea repeaters; nuclear power control systems; aircraft control systems; key plant systems; military equipment; etc.). Renesas Electronics disclaims any and all liability for any damages or losses incurred by you or any third parties arising from the use of any Renesas Electronics product that is inconsistent with any Renesas Electronics data sheet, user's manual or other Renesas Electronics document.
6. When using Renesas Electronics products, refer to the latest product information (data sheets, user's manuals, application notes, "General Notes for Handling and Using Semiconductor Devices" in the reliability handbook, etc.), and ensure that usage conditions are within the ranges specified by Renesas Electronics with respect to maximum ratings, operating power supply voltage range, heat dissipation characteristics, installation, etc. Renesas Electronics disclaims any and all liability for any malfunctions, failure or accident arising out of the use of Renesas Electronics products outside of such specified ranges.
7. Although Renesas Electronics endeavors to improve the quality and reliability of Renesas Electronics products, semiconductor products have specific characteristics, such as the occurrence of failure at a certain rate and malfunctions under certain use conditions. Unless designated as a high reliability product or a product for harsh environments in a Renesas Electronics data sheet or other Renesas Electronics document, Renesas Electronics products are not subject to radiation resistance design. You are responsible for implementing safety measures to guard against the possibility of bodily injury, injury or damage caused by fire, and/or danger to the public in the event of a failure or malfunction of Renesas Electronics products, such as safety design for hardware and software, including but not limited to redundancy, fire control and malfunction prevention, appropriate treatment for aging degradation or any other appropriate measures. Because the evaluation of microcomputer software alone is very difficult and impractical, you are responsible for evaluating the safety of the final products or systems manufactured by you.
8. Please contact a Renesas Electronics sales office for details as to environmental matters such as the environmental compatibility of each Renesas Electronics product. You are responsible for carefully and sufficiently investigating applicable laws and regulations that regulate the inclusion or use of controlled substances, including without limitation, the EU RoHS Directive, and using Renesas Electronics products in compliance with all these applicable laws and regulations. Renesas Electronics disclaims any and all liability for damages or losses occurring as a result of your noncompliance with applicable laws and regulations.
9. Renesas Electronics products and technologies shall not be used for or incorporated into any products or systems whose manufacture, use, or sale is prohibited under any applicable domestic or foreign laws or regulations. You shall comply with any applicable export control laws and regulations promulgated and administered by the governments of any countries asserting jurisdiction over the parties or transactions.
10. It is the responsibility of the buyer or distributor of Renesas Electronics products, or any other party who distributes, disposes of, or otherwise sells or transfers the product to a third party, to notify such third party in advance of the contents and conditions set forth in this document.
11. This document shall not be reprinted, reproduced or duplicated in any form, in whole or in part, without prior written consent of Renesas Electronics.
12. Please contact a Renesas Electronics sales office if you have any questions regarding the information contained in this document or Renesas Electronics products.

(Note1) "Renesas Electronics" as used in this document means Renesas Electronics Corporation and also includes its directly or indirectly controlled subsidiaries.

(Note2) "Renesas Electronics product(s)" means any product developed or manufactured by or for Renesas Electronics.

(Rev.4.0-1 November 2017)

Corporate Headquarters

TOYOSU FORESIA, 3-2-24 Toyosu,
Koto-ku, Tokyo 135-0061, Japan
www.renesas.com

Contact Information

For further information on a product, technology, the most up-to-date version of a document, or your nearest sales office, please visit:
www.renesas.com/contact/

Trademarks

Renesas and the Renesas logo are trademarks of Renesas Electronics Corporation. All trademarks and registered trademarks are the property of their respective owners.