

# SN74AXC8T245 8-Bit Dual-Supply Bus Transceiver With Configurable Voltage Translation and Tri-State Outputs

## 1 Features

- Qualified Fully Configurable Dual-Rail Design Allows Each Port to Operate With a Power Supply Range From 0.65 V to 3.6 V
- Operating Temperature From  $-40^{\circ}\text{C}$  to  $+125^{\circ}\text{C}$
- Multiple Direction Control Pins to Allow Simultaneous Up and Down Translation
- Up to 380 Mbps Support When Translating from 1.8 V to 3.3 V
- $V_{CC}$  Isolation Feature to Effectively Isolate Both Buses in a Power-Down Scenario
- Partial Power-Down Mode to Limit Backflow Current in a Power-Down Scenario
- Compatible With SN74AVC8T245 and 74AVC8T245 Level Shifters
- Latch-Up Performance Exceeds 100 mA Per JESD 78, Class II
- ESD Protection Exceeds JESD 22
  - 8000-V Human-Body Model
  - 1000-V Charged-Device Model

## 2 Applications

- Enterprise and Communications
- Industrial
- Personal Electronics
- Wireless Infrastructure
- Building Automation
- Point of Sale

## 3 Description

The SN74AXC8T245 device is an 8-bit non-inverting bus transceiver that resolves voltage level mismatch between devices operating at the latest voltage nodes (0.7 V, 0.8 V, and 0.9 V) and devices operating at industry standard voltage nodes (1.8 V, 2.5 V, 3.3 V) and vice versa.

The device operates by using two independent power-supply rails ( $V_{CCA}$  and  $V_{CCB}$ ) that operate as low as 0.65 V. Data pins A1 through A8 are designed to track  $V_{CCA}$ , which accepts any supply voltage from 0.65 V to 3.6 V. Data pins B1 through B8 are designed to track  $V_{CCB}$ , which accepts any supply voltage from 0.65 V to 3.6 V.

The SN74AXC8T245 device is designed for asynchronous communication between data buses. The device transmits data from the A bus to the B bus or from the B bus to the A bus, depending on the logic level of the direction-control inputs (DIR1 and DIR2). The output-enable ( $\overline{OE}$ ) input is used to disable the outputs so the buses are effectively isolated.

The SN74AXC8T245 device is designed so the control pins (DIR and  $\overline{OE}$ ) are referenced to  $V_{CCA}$ .

This device is fully specified for partial-power-down applications using  $I_{off}$ . The  $I_{off}$  circuitry disables the outputs when the device is powered down. This inhibits current backflow into the device which prevents damage to the device.

The  $V_{CC}$  isolation feature ensures that if either  $V_{CC}$  input supply is below 100 mV, all level shifter outputs are disabled and placed into a high-impedance state.

To ensure the high-impedance state of the level shifter I/Os during power up or power down,  $\overline{OE}$  should be tied to  $V_{CCA}$  through a pullup resistor; the minimum value of the resistor is determined by the current-sinking capability of the driver.

### Device Information<sup>(1)</sup>

PART NUMBER	PACKAGE	BODY SIZE (NOM)
SN74AXC8T245PW	TSSOP (24)	4.40 mm × 7.80 mm
SN74AXC8T245RHL	VQFN (24)	3.50 mm × 5.50 mm
SN74AXC8T245RJW	UQFN (24)	2.00 mm × 4.00 mm

(1) For all available packages, see the orderable addendum at the end of the data sheet.

### Typical Application Schematic

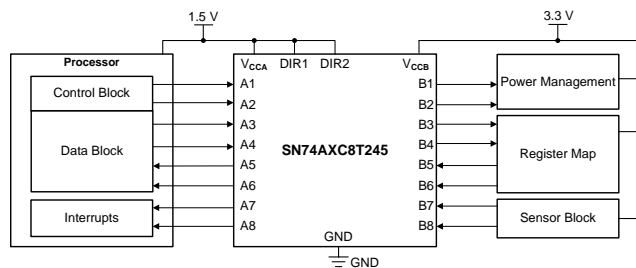

## Table of Contents

<b>1 Features</b> .....	<b>1</b>	<b>8 Detailed Description</b> .....	<b>20</b>
<b>2 Applications</b> .....	<b>1</b>	8.1 Overview .....	20
<b>3 Description</b> .....	<b>1</b>	8.2 Functional Block Diagram .....	20
<b>4 Revision History</b> .....	<b>2</b>	8.3 Feature Description .....	21
<b>5 Pin Configuration and Functions</b> .....	<b>3</b>	8.4 Device Functional Modes .....	21
<b>6 Specifications</b> .....	<b>5</b>	<b>9 Application and Implementation</b> .....	<b>22</b>
6.1 Absolute Maximum Ratings .....	5	9.1 Application Information .....	22
6.2 ESD Ratings .....	5	9.2 Typical Application .....	22
6.3 Recommended Operating Conditions .....	6	<b>10 Power Supply Recommendations</b> .....	<b>24</b>
6.4 Thermal Information .....	6	<b>11 Layout</b> .....	<b>24</b>
6.5 Electrical Characteristics .....	7	11.1 Layout Guidelines .....	24
6.6 Switching Characteristics, $V_{CCA} = 0.7\text{ V}$ .....	8	11.2 Layout Example .....	24
6.7 Switching Characteristics, $V_{CCA} = 0.8\text{ V}$ .....	9	<b>12 Device and Documentation Support</b> .....	<b>25</b>
6.8 Switching Characteristics, $V_{CCA} = 0.9\text{ V}$ .....	10	12.1 Documentation Support .....	25
6.9 Switching Characteristics, $V_{CCA} = 1.2\text{ V}$ .....	11	12.2 Receiving Notification of Documentation Updates .....	25
6.10 Switching Characteristics, $V_{CCA} = 1.5\text{ V}$ .....	12	12.3 Community Resources .....	25
6.11 Switching Characteristics, $V_{CCA} = 1.8\text{ V}$ .....	13	12.4 Trademarks .....	25
6.12 Switching Characteristics, $V_{CCA} = 2.5\text{ V}$ .....	14	12.5 Electrostatic Discharge Caution .....	25
6.13 Switching Characteristics, $V_{CCA} = 3.3\text{ V}$ .....	15	12.6 Glossary .....	25
6.14 Operating Characteristics: $T_A = 25^\circ\text{C}$ .....	16	<b>13 Mechanical, Packaging, and Orderable Information</b> .....	<b>25</b>
<b>7 Parameter Measurement Information</b> .....	<b>18</b>		

## 4 Revision History

<b>Changes from Revision A (July 2018) to Revision B</b>	<b>Page</b>
• Changed data sheet status from Mixed Production to Production Data .....	1
• Removed package preview note from RJW package .....	1

---

<b>Changes from Original (March 2018) to Revision A</b>	<b>Page</b>
• Added RJW as a new package option (preview) .....	1

## 5 Pin Configuration and Functions

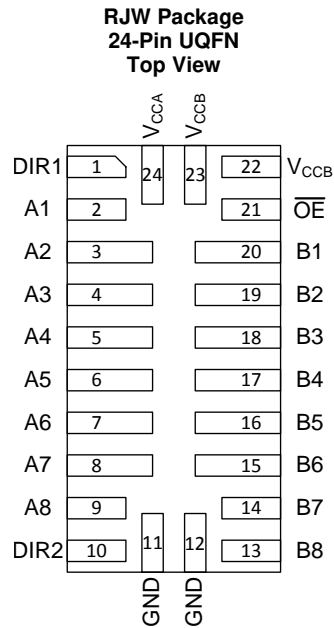
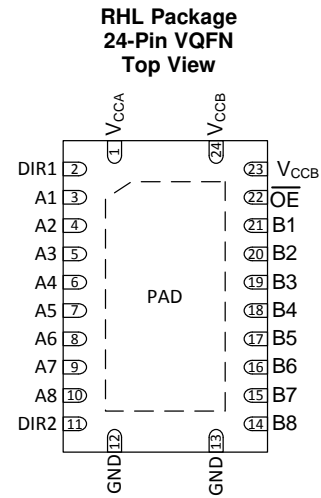
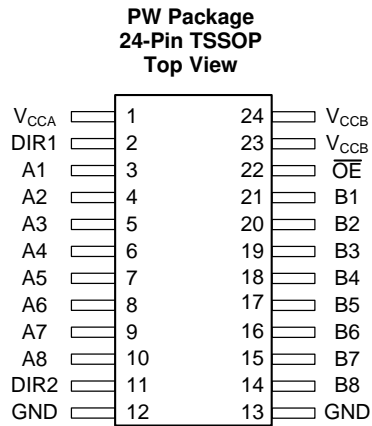

### Pin Functions

NAME	PIN		I/O	DESCRIPTION
	PW, RHL	RJW		
A1	3	2	I/O	Input/output A1. Referenced to $V_{CCA}$ .
A2	4	3	I/O	Input/output A2. Referenced to $V_{CCA}$ .
A3	5	4	I/O	Input/output A3. Referenced to $V_{CCA}$ .
A4	6	5	I/O	Input/output A4. Referenced to $V_{CCA}$ .
A5	7	6	I/O	Input/output A5. Referenced to $V_{CCA}$ .
A6	8	7	I/O	Input/output A6. Referenced to $V_{CCA}$ .
A7	9	8	I/O	Input/output A7. Referenced to $V_{CCA}$ .
A8	10	9	I/O	Input/output A8. Referenced to $V_{CCA}$ .
B1	21	20	I/O	Input/output B1. Referenced to $V_{CCB}$ .
B2	20	19	I/O	Input/output B2. Referenced to $V_{CCB}$ .
B3	19	18	I/O	Input/output B3. Referenced to $V_{CCB}$ .
B4	18	17	I/O	Input/output B4. Referenced to $V_{CCB}$ .
B5	17	16	I/O	Input/output B5. Referenced to $V_{CCB}$ .
B6	16	15	I/O	Input/output B6. Referenced to $V_{CCB}$ .
B7	15	14	I/O	Input/output B7. Referenced to $V_{CCB}$ .
B8	14	13	I/O	Input/output B8. Referenced to $V_{CCB}$ .
DIR1	2	1	I	Direction-control signal. Referenced to $V_{CCA}$ .
DIR2	11	10	I	Direction-control signal when both $V_{CCA}$ and $V_{CCB} \geq 1.4$ V. Referenced to $V_{CCA}$ . Tie to GND to maintain backward compatibility with SN74AVC8T245 device.
GND	12	11	—	Ground
	13	12	—	Ground
$\overline{OE}$	22	21	I	Output Enable. Pull to GND to enable all outputs. Pull to $V_{CCA}$ to place all outputs in high-impedance mode. Referenced to $V_{CCA}$ .
$V_{CCA}$	1	24	—	A-port supply voltage. $0.65 \text{ V} \leq V_{CCA} \leq 3.6 \text{ V}$
$V_{CCB}$	23	22	—	B-port supply voltage. $0.65 \text{ V} \leq V_{CCB} \leq 3.6 \text{ V}$
	24	23	—	B-port supply voltage. $0.65 \text{ V} \leq V_{CCB} \leq 3.6 \text{ V}$

## 6 Specifications

### 6.1 Absolute Maximum Ratings

over operating free-air temperature range (unless otherwise noted)<sup>(1)</sup>

		MIN	MAX	UNIT
Supply voltage, $V_{CCA}$		-0.5	4.2	V
Supply voltage, $V_{CCB}$		-0.5	4.2	V
Input voltage, $V_I$ <sup>(2)</sup>	I/O ports (A port)	-0.5	4.2	V
	I/O ports (B port)	-0.5	4.2	
	Control inputs	-0.5	4.2	
Voltage applied to any output in the high-impedance or power-off state, $V_O$ <sup>(2)</sup>	A port	-0.5	4.2	V
	B port	-0.5	4.2	
Voltage applied to any output in the high or low state, $V_O$ <sup>(2) (3)</sup>	A port	-0.5	$V_{CCA} + 0.2$	V
	B port	-0.5	$V_{CCB} + 0.2$	
Input clamp current, $I_{IK}$	$V_I < 0$	-50		mA
Output clamp current, $I_{OK}$	$V_O < 0$	-50		mA
Continuous output current, $I_O$		-50	50	mA
Continuous current through $V_{CCA}$ , $V_{CCB}$ , or GND		-100	100	mA
Junction Temperature, $T_J$			150	°C
Storage temperature, $T_{stg}$		-65	150	°C

- (1) Stresses beyond those listed under *Absolute Maximum Ratings* may cause permanent damage to the device. These are stress ratings only, which do not imply functional operation of the device at these or any other conditions beyond those indicated under *Recommended Operating Conditions*. Exposure to absolute-maximum-rated conditions for extended periods may affect device reliability.
- (2) The input voltage and output negative-voltage ratings may be exceeded if the input and output current ratings are observed.
- (3) The output positive-voltage rating may be exceeded up to 4.2 V maximum if the output current rating is observed.

### 6.2 ESD Ratings

		VALUE	UNIT
$V_{(ESD)}$ Electrostatic discharge	Human-body model (HBM), per ANSI/ESDA/JEDEC JS-001 <sup>(1)</sup>	±8000	V
	Charged-device model (CDM), per JEDEC specification JESD22-C101 <sup>(2)</sup>	±1000	

- (1) JEDEC document JEP155 states that 500-V HBM allows safe manufacturing with a standard ESD control process.
- (2) JEDEC document JEP157 states that 250-V CDM allows safe manufacturing with a standard ESD control process.

### 6.3 Recommended Operating Conditions

 over operating free-air temperature range (unless otherwise noted) <sup>(1)(2)(3)</sup>

		MIN	MAX	UNIT	
V <sub>CCA</sub>	Supply voltage	0.65	3.6	V	
V <sub>CCB</sub>	Supply voltage	0.65	3.6	V	
V <sub>IH</sub>	High-level input voltage	Data inputs	V <sub>CCI</sub> = 0.65 V - 0.75 V	V <sub>CCI</sub> × 0.70	V
			V <sub>CCI</sub> = 0.76 V - 1 V	V <sub>CCI</sub> × 0.70	
			V <sub>CCI</sub> = 1.1 V - 1.95 V	V <sub>CCI</sub> × 0.65	
			V <sub>CCI</sub> = 2.3 V - 2.7 V	1.6	
			V <sub>CCI</sub> = 3 V - 3.6 V	2	
	Control inputs (DIR, $\overline{OE}$ ) Referenced to V <sub>CCA</sub>	V <sub>CCA</sub> = 0.65 V - 0.75 V	V <sub>CCA</sub> × 0.70		
		V <sub>CCA</sub> = 0.76 V - 1 V	V <sub>CCA</sub> × 0.70		
		V <sub>CCA</sub> = 1.1 V - 1.95 V	V <sub>CCA</sub> × 0.65		
		V <sub>CCA</sub> = 2.3 V - 2.7 V	1.6		
		V <sub>CCA</sub> = 3 V - 3.6 V	2		
V <sub>IL</sub>	Low-level input voltage	Data inputs	V <sub>CCI</sub> = 0.65 V - 0.75 V	V <sub>CCI</sub> × 0.30	V
			V <sub>CCI</sub> = 0.76 V - 1 V	V <sub>CCI</sub> × 0.30	
			V <sub>CCI</sub> = 1.1 V - 1.95 V	V <sub>CCI</sub> × 0.35	
			V <sub>CCI</sub> = 2.3 V - 2.7 V	0.7	
			V <sub>CCI</sub> = 3 V - 3.6 V	0.8	
	Control inputs (DIR, $\overline{OE}$ ) Referenced to V <sub>CCA</sub>	V <sub>CCA</sub> = 0.65 V - 0.75 V	V <sub>CCA</sub> × 0.30		
		V <sub>CCA</sub> = 0.76 V - 1 V	V <sub>CCA</sub> × 0.30		
		V <sub>CCA</sub> = 1.1 V - 1.95 V	V <sub>CCA</sub> × 0.35		
		V <sub>CCA</sub> = 2.3 V - 2.7 V	0.7		
		V <sub>CCA</sub> = 3 V - 3.6 V	0.8		
V <sub>I</sub>	Input voltage <sup>(3)</sup>	0	3.6	V	
V <sub>O</sub>	Output voltage	Active state	0	V <sub>CCO</sub> <sup>(2)</sup>	V
		Tri-state	0	3.6	
$\Delta t/\Delta v$	Input transition rise or fall rate		10	ns/V	
T <sub>A</sub>	Operating free-air temperature	-40	125	°C	

(1) V<sub>CCI</sub> is the V<sub>CC</sub> associated with the input port.

(2) V<sub>CCO</sub> is the V<sub>CC</sub> associated with the output port.

(3) All unused data inputs of the device must be held at V<sub>CCI</sub> or GND to ensure proper device operation. See the [Implications of Slow or Floating CMOS Inputs](#) application report.

### 6.4 Thermal Information

THERMAL METRIC	SN74AXC8T245			UNIT	
	PW (TSSOP)	RHL (VQFN)	RJW (UQFN)		
	24 PINS	24 PINS	24 PINS		
R <sub>θJA</sub>	Junction-to-ambient thermal resistance	92.0	35.0	123.1	°C/W
R <sub>θJC(top)</sub>	Junction-to-case (top) thermal resistance	29.3	39.9	65.0	°C/W
R <sub>θJB</sub>	Junction-to-board thermal resistance	46.7	13.8	55.3	°C/W
ψ <sub>JT</sub>	Junction-to-top characterization parameter	1.5	0.3	3.9	°C/W
ψ <sub>JB</sub>	Junction-to-board characterization parameter	46.2	13.8	54.9	°C/W
R <sub>θJC(bot)</sub>	Junction-to-case (bottom) thermal resistance	N/A	1.4	N/A	°C/W

## 6.5 Electrical Characteristics

Over recommended operating free-air temperature range (unless otherwise noted)<sup>(1)</sup>

PARAMETER	TEST CONDITIONS	V <sub>CCA</sub>	V <sub>CCB</sub>	–40°C to 85°C			–40°C to 125°C			UNIT
				MIN	TYP <sup>(2)</sup>	MAX	MIN	TYP <sup>(2)</sup>	MAX	
V <sub>OH</sub> High-level output voltage	V <sub>I</sub> = V <sub>IH</sub>	I <sub>OH</sub> = –100 μA	0.7 V - 3.6 V	0.7 V - 3.6 V	V <sub>CCO</sub> – 0.1			V <sub>CCO</sub> – 0.1		
		I <sub>OH</sub> = –50 μA	0.65 V	0.65 V	0.55			0.55		
		I <sub>OH</sub> = –200 μA	0.76 V	0.76 V	0.58			0.58		
		I <sub>OH</sub> = –500 μA	0.85 V	0.85 V	0.65			0.65		
		I <sub>OH</sub> = –3 mA	1.1 V	1.1 V	0.85			0.85		
		I <sub>OH</sub> = –6 mA	1.4 V	1.4 V	1.05			1.05		
		I <sub>OH</sub> = –8 mA	1.65 V	1.65 V	1.2			1.2		
		I <sub>OH</sub> = –9 mA	2.3 V	2.3 V	1.75			1.75		
		I <sub>OH</sub> = –12 mA	3 V	3 V	2.3			2.3		
V <sub>OL</sub> Low-level output voltage	V <sub>I</sub> = V <sub>IL</sub>	I <sub>OL</sub> = 100 μA	0.7 V - 3.6 V	0.7 V - 3.6 V	0.1			0.1		
		I <sub>OL</sub> = 50 μA	0.65 V	0.65 V	0.1			0.1		
		I <sub>OL</sub> = 200 μA	0.76 V	0.76 V	0.18			0.18		
		I <sub>OL</sub> = 500 μA	0.85 V	0.85 V	0.2			0.2		
		I <sub>OL</sub> = 3 mA	1.1 V	1.1 V	0.25			0.25		
		I <sub>OL</sub> = 6 mA	1.4 V	1.4 V	0.35			0.35		
		I <sub>OL</sub> = 8 mA	1.65 V	1.65 V	0.45			0.45		
		I <sub>OL</sub> = 9 mA	2.3 V	2.3 V	0.55			0.55		
I <sub>OL</sub> = 12 mA	3 V	3 V	0.7			0.7				
I <sub>I</sub> Input leakage current	Control Inputs (DIR, $\overline{OE}$ ): V <sub>I</sub> = V <sub>CCA</sub> or GND	0.65 V - 3.6 V	0.65 V - 3.6 V	–0.5			0.5			
I <sub>off</sub> Partial power down current	A Port: V <sub>I</sub> or V <sub>O</sub> = 0 V - 3.6 V	0 V	0 V - 3.6 V	–4			4			
	B Port: V <sub>I</sub> or V <sub>O</sub> = 0 V - 3.6 V	0 V - 3.6 V	0 V	–4			4			
I <sub>OZ</sub> High-impedance state output current	A Port: V <sub>O</sub> = V <sub>CCO</sub> or GND, V <sub>I</sub> = V <sub>CCI</sub> or GND, $\overline{OE}$ = V <sub>IH</sub>	3.6 V	3.6 V	–4			4			
	B Port: V <sub>O</sub> = V <sub>CCO</sub> or GND, V <sub>I</sub> = V <sub>CCI</sub> or GND, $\overline{OE}$ = V <sub>IH</sub>	3.6 V	3.6 V	–4			4			
I <sub>CCA</sub> V <sub>CCA</sub> supply current	V <sub>I</sub> = V <sub>CCI</sub> or GND, I <sub>O</sub> = 0 mA	0.65 V - 3.6 V	0.65 V - 3.6 V	19			40			
		0 V	3.6 V	–2			–12			
		3.6 V	0 V	12			25			
I <sub>CCB</sub> V <sub>CCB</sub> supply current	V <sub>I</sub> = V <sub>CCI</sub> or GND, I <sub>O</sub> = 0 mA	0.65 V - 3.6 V	0.65 V - 3.6 V	18			38			
		0 V	3.6 V	12			25			
		3.6 V	0 V	–2			–12			
I <sub>CCA</sub> + I <sub>CCB</sub> Combined supply current	V <sub>I</sub> = V <sub>CCI</sub> or GND, I <sub>O</sub> = 0 mA	0.65 V - 3.6 V	0.65 V - 3.6 V	25			55			
C <sub>i</sub> Input capacitance	Control Inputs (DIR, $\overline{OE}$ ): V <sub>I</sub> = 3.3 V or GND	3.3 V	3.3 V	4.5			4.5			
C <sub>io</sub> Data I/O capacitance	Ports A and B: $\overline{OE}$ = V <sub>CCA</sub> , V <sub>O</sub> = 1.65V DC + 1 MHz –16 dBm sine wave	3.3 V	3.3 V	5.7			5.7			

(1) V<sub>CCO</sub> is the V<sub>CC</sub> associated with the output port.

(2) All typical values are for T<sub>A</sub> = 25°C

## 6.6 Switching Characteristics, $V_{CCA} = 0.7\text{ V}$

See [Figure 1](#) and [Figure 2](#) for test circuit and loading conditions. See [Figure 3](#) and [Figure 4](#) for measurement waveforms.

PARAMETER	TEST CONDITIONS		B-PORT SUPPLY VOLTAGE ( $V_{CCB}$ )								UNIT
			0.7 V $\pm$ 0.05 V		0.8 V $\pm$ 0.04 V		0.9 V $\pm$ 0.045 V		1.2 V $\pm$ 0.1 V		
			MIN	MAX	MIN	MAX	MIN	MAX	MIN	MAX	
$t_{pd}$ Propagation delay	From input A to output B	-40°C to 85°C	0.5	172	0.5	114	0.5	82	0.5	49	ns
		-40°C to 125°C	0.5	172	0.5	114	0.5	82	0.5	49	
	From input B to output A	-40°C to 85°C	0.5	172	0.5	153	0.5	126	0.5	88	
		-40°C to 125°C	0.5	172	0.5	153	0.5	126	0.5	88	
$t_{dis}$ Disable time	From input $\overline{OE}$ to output A	-40°C to 85°C	0.5	192	0.5	192	0.5	192	0.5	192	ns
		-40°C to 125°C	0.5	195	0.5	195	0.5	195	0.5	195	
	From input $\overline{OE}$ to output B	-40°C to 85°C	0.5	156	0.5	129	0.5	118	0.5	120	
		-40°C to 125°C	0.5	157	0.5	129	0.5	120	0.5	122	
$t_{en}$ Enable time	From input $\overline{OE}$ to output A	-40°C to 85°C	0.5	237	0.5	237	0.5	237	0.5	237	ns
		-40°C to 125°C	0.5	237	0.5	237	0.5	237	0.5	237	
	From input $\overline{OE}$ to output B	-40°C to 85°C	0.5	223	0.5	145	0.5	106	0.5	74	
		-40°C to 125°C	0.5	223	0.5	145	0.5	106	0.5	74	

PARAMETER	TEST CONDITIONS		B-PORT SUPPLY VOLTAGE ( $V_{CCB}$ )								UNIT
			1.5 V $\pm$ 0.1 V		1.8 V $\pm$ 0.15 V		2.5 V $\pm$ 0.2 V		3.3 V $\pm$ 0.3 V		
			MIN	MAX	MIN	MAX	MIN	MAX	MIN	MAX	
$t_{pd}$ Propagation delay	From input A to output B	-40°C to 85°C	0.5	46	0.5	49	0.5	61	0.5	142	ns
		-40°C to 125°C	0.5	46	0.5	49	0.5	61	0.5	142	
	From input B to output A	-40°C to 85°C	0.5	83	0.5	82	0.5	81	0.5	81	
		-40°C to 125°C	0.5	83	0.5	82	0.5	81	0.5	81	
$t_{dis}$ Disable time	From input $\overline{OE}$ to output A	-40°C to 85°C	0.5	192	0.5	192	0.5	192	0.5	192	ns
		-40°C to 125°C	0.5	195	0.5	195	0.5	195	0.5	195	
	From input $\overline{OE}$ to output B	-40°C to 85°C	0.5	69	0.5	66	0.5	67	0.5	150	
		-40°C to 125°C	0.5	70	0.5	67	0.5	67	0.5	150	
$t_{en}$ Enable time	From input $\overline{OE}$ to output A	-40°C to 85°C	0.5	237	0.5	237	0.5	237	0.5	237	ns
		-40°C to 125°C	0.5	237	0.5	237	0.5	237	0.5	237	
	From input $\overline{OE}$ to output B	-40°C to 85°C	0.5	68	0.5	69	0.5	84	0.5	552	
		-40°C to 125°C	0.5	68	0.5	69	0.5	84	0.5	552	



## 6.7 Switching Characteristics, $V_{CCA} = 0.8\text{ V}$

See [Figure 1](#) and [Figure 2](#) for test circuit and loading conditions. See [Figure 3](#) and [Figure 4](#) for measurement waveforms.

PARAMETER	TEST CONDITIONS		B-PORT SUPPLY VOLTAGE ( $V_{CCB}$ )								UNIT
			0.7 V $\pm$ 0.05 V		0.8 V $\pm$ 0.04 V		0.9 V $\pm$ 0.045 V		1.2 V $\pm$ 0.1 V		
			MIN	MAX	MIN	MAX	MIN	MAX	MIN	MAX	
$t_{pd}$ Propagation delay	From input A to output B	-40°C to 85°C	0.5	153	0.5	95	0.5	62	0.5	32	ns
		-40°C to 125°C	0.5	153	0.5	95	0.5	62	0.5	32	
	From input B to output A	-40°C to 85°C	0.5	114	0.5	95	0.5	78	0.5	52	
		-40°C to 125°C	0.5	114	0.5	95	0.5	78	0.5	52	
$t_{dis}$ Disable time	From input $\overline{OE}$ to output A	-40°C to 85°C	0.5	101	0.5	101	0.5	101	0.5	101	ns
		-40°C to 125°C	0.5	103	0.5	103	0.5	103	0.5	103	
	From input $\overline{OE}$ to output B	-40°C to 85°C	0.5	141	0.5	114	0.5	104	0.5	106	
		-40°C to 125°C	0.5	142	0.5	115	0.5	106	0.5	109	
$t_{en}$ Enable time	From input $\overline{OE}$ to output A	-40°C to 85°C	0.5	102	0.5	102	0.5	102	0.5	102	ns
		-40°C to 125°C	0.5	102	0.5	102	0.5	102	0.5	102	
	From input $\overline{OE}$ to output B	-40°C to 85°C	0.5	202	0.5	124	0.5	86	0.5	52	
		-40°C to 125°C	0.5	202	0.5	124	0.5	86	0.5	52	

PARAMETER	TEST CONDITIONS		B-PORT SUPPLY VOLTAGE ( $V_{CCB}$ )								UNIT
			1.5 V $\pm$ 0.1 V		1.8 V $\pm$ 0.15 V		2.5 V $\pm$ 0.2 V		3.3 V $\pm$ 0.3 V		
			MIN	MAX	MIN	MAX	MIN	MAX	MIN	MAX	
$t_{pd}$ Propagation delay	From input A to output B	-40°C to 85°C	0.5	26	0.5	25	0.5	25	0.5	35	ns
		-40°C to 125°C	0.5	26	0.5	25	0.5	25	0.5	35	
	From input B to output A	-40°C to 85°C	0.5	42	0.5	41	0.5	40	0.5	40	
		-40°C to 125°C	0.5	42	0.5	41	0.5	40	0.5	40	
$t_{dis}$ Disable time	From input $\overline{OE}$ to output A	-40°C to 85°C	0.5	101	0.5	101	0.5	101	0.5	101	ns
		-40°C to 125°C	0.5	103	0.5	103	0.5	103	0.5	103	
	From input $\overline{OE}$ to output B	-40°C to 85°C	0.5	55	0.5	51	0.5	49	0.5	51	
		-40°C to 125°C	0.5	57	0.5	53	0.5	50	0.5	52	
$t_{en}$ Enable time	From input $\overline{OE}$ to output A	-40°C to 85°C	0.5	102	0.5	102	0.5	102	0.5	102	ns
		-40°C to 125°C	0.5	102	0.5	102	0.5	102	0.5	102	
	From input $\overline{OE}$ to output B	-40°C to 85°C	0.5	44	0.5	43	0.5	45	0.5	58	
		-40°C to 125°C	0.5	44	0.5	43	0.5	45	0.5	58	

## SN74AXC8T245

SCES875B – MARCH 2018 – REVISED AUGUST 2018

www.ti.com

### 6.8 Switching Characteristics, $V_{CCA} = 0.9\text{ V}$

See [Figure 1](#) and [Figure 2](#) for test circuit and loading conditions. See [Figure 3](#) and [Figure 4](#) for measurement waveforms.

PARAMETER	TEST CONDITIONS		B-PORT SUPPLY VOLTAGE ( $V_{CCB}$ )								UNIT
			0.7 V $\pm$ 0.05 V		0.8 V $\pm$ 0.04 V		0.9 V $\pm$ 0.045 V		1.2 V $\pm$ 0.1 V		
			MIN	MAX	MIN	MAX	MIN	MAX	MIN	MAX	
$t_{pd}$ Propagation delay	From input A to output B	-40°C to 85°C	0.5	127	0.5	78	0.5	52	0.5	23	ns
		-40°C to 125°C	0.5	127	0.5	78	0.5	52	0.5	23	
	From input B to output A	-40°C to 85°C	0.5	82	0.5	63	0.5	52	0.5	39	
		-40°C to 125°C	0.5	82	0.5	63	0.5	52	0.5	39	
$t_{dis}$ Disable time	From input $\overline{OE}$ to output A	-40°C to 85°C	0.5	125	0.5	125	0.5	125	0.5	125	ns
		-40°C to 125°C	0.5	128	0.5	128	0.5	128	0.5	128	
	From input $\overline{OE}$ to output B	-40°C to 85°C	0.5	131	0.5	105	0.5	96	0.5	99	
		-40°C to 125°C	0.5	133	0.5	107	0.5	98	0.5	101	
$t_{en}$ Enable time	From input $\overline{OE}$ to output A	-40°C to 85°C	0.5	124	0.5	124	0.5	124	0.5	124	ns
		-40°C to 125°C	0.5	128	0.5	128	0.5	128	0.5	128	
	From input $\overline{OE}$ to output B	-40°C to 85°C	0.5	191	0.5	113	0.5	75	0.5	41	
		-40°C to 125°C	0.5	191	0.5	113	0.5	75	0.5	41	

PARAMETER	TEST CONDITIONS		B-PORT SUPPLY VOLTAGE ( $V_{CCB}$ )								UNIT
			1.5 V $\pm$ 0.1 V		1.8 V $\pm$ 0.15 V		2.5 V $\pm$ 0.2 V		3.3 V $\pm$ 0.3 V		
			MIN	MAX	MIN	MAX	MIN	MAX	MIN	MAX	
$t_{pd}$ Propagation delay	From input A to output B	-40°C to 85°C	0.5	17	0.5	15	0.5	14	0.5	17	ns
		-40°C to 125°C	0.5	17	0.5	15	0.5	14	0.5	17	
	From input B to output A	-40°C to 85°C	0.5	28	0.5	24	0.5	22	0.5	22	
		-40°C to 125°C	0.5	28	0.5	24	0.5	22	0.5	22	
$t_{dis}$ Disable time	From input $\overline{OE}$ to output A	-40°C to 85°C	0.5	125	0.5	125	0.5	125	0.5	125	ns
		-40°C to 125°C	0.5	128	0.5	128	0.5	128	0.5	128	
	From input $\overline{OE}$ to output B	-40°C to 85°C	0.5	47	0.5	44	0.5	40	0.5	73	
		-40°C to 125°C	0.5	50	0.5	46	0.5	42	0.5	73	
$t_{en}$ Enable time	From input $\overline{OE}$ to output A	-40°C to 85°C	0.5	124	0.5	124	0.5	124	0.5	124	ns
		-40°C to 125°C	0.5	128	0.5	128	0.5	128	0.5	128	
	From input $\overline{OE}$ to output B	-40°C to 85°C	0.5	34	0.5	32	0.5	31	0.5	35	
		-40°C to 125°C	0.5	34	0.5	32	0.5	31	0.5	35	

## 6.9 Switching Characteristics, $V_{CCA} = 1.2\text{ V}$

See [Figure 1](#) and [Figure 2](#) for test circuit and loading conditions. See [Figure 3](#) and [Figure 4](#) for measurement waveforms.

PARAMETER	TEST CONDITIONS		B-PORT SUPPLY VOLTAGE ( $V_{CCB}$ )								UNIT
			0.7 V ± 0.05 V		0.8 V ± 0.04 V		0.9 V ± 0.045 V		1.2 V ± 0.1 V		
			MIN	MAX	MIN	MAX	MIN	MAX	MIN	MAX	
$t_{pd}$ Propagation delay	From input A to output B	–40°C to 85°C	0.5	88	0.5	52	0.5	39	0.5	15	ns
		–40°C to 125°C	0.5	88	0.5	52	0.5	39	0.5	15	
	From input B to output A	–40°C to 85°C	0.5	49	0.5	32	0.5	23	0.5	15	
		–40°C to 125°C	0.5	49	0.5	32	0.5	23	0.5	15	
$t_{dis}$ Disable time	From input $\overline{OE}$ to output A	–40°C to 85°C	0.5	87	0.5	87	0.5	87	0.5	87	ns
		–40°C to 125°C	0.5	91	0.5	91	0.5	91	0.5	91	
	From input $\overline{OE}$ to output B	–40°C to 85°C	0.5	119	0.5	94	0.5	85	0.5	89	
		–40°C to 125°C	0.5	121	0.5	96	0.5	88	0.5	93	
$t_{en}$ Enable time	From input $\overline{OE}$ to output A	–40°C to 85°C	0.5	34	0.5	34	0.5	34	0.5	34	ns
		–40°C to 125°C	0.5	36	0.5	36	0.5	36	0.5	36	
	From input $\overline{OE}$ to output B	–40°C to 85°C	0.5	168	0.5	98	0.5	61	0.5	29	
		–40°C to 125°C	0.5	168	0.5	98	0.5	61	0.5	30	

PARAMETER	TEST CONDITIONS		B-PORT SUPPLY VOLTAGE ( $V_{CCB}$ )								UNIT
			1.5 V ± 0.1 V		1.8 V ± 0.15 V		2.5 V ± 0.2 V		3.3 V ± 0.3 V		
			MIN	MAX	MIN	MAX	MIN	MAX	MIN	MAX	
$t_{pd}$ Propagation delay	From input A to output B	–40°C to 85°C	0.5	10	0.5	9	0.5	7	0.5	7	ns
		–40°C to 125°C	0.5	10	0.5	9	0.5	7	0.5	8	
	From input B to output A	–40°C to 85°C	0.5	13	0.5	11	0.5	8	0.5	7	
		–40°C to 125°C	0.5	13	0.5	11	0.5	8	0.5	7	
$t_{dis}$ Disable time	From input $\overline{OE}$ to output A	–40°C to 85°C	0.5	87	0.5	87	0.5	87	0.5	87	ns
		–40°C to 125°C	0.5	91	0.5	91	0.5	91	0.5	91	
	From input $\overline{OE}$ to output B	–40°C to 85°C	0.5	38	0.5	35	0.5	31	0.5	29	
		–40°C to 125°C	0.5	41	0.5	38	0.5	33	0.5	31	
$t_{en}$ Enable time	From input $\overline{OE}$ to output A	–40°C to 85°C	0.5	34	0.5	34	0.5	34	0.5	34	ns
		–40°C to 125°C	0.5	36	0.5	36	0.5	36	0.5	36	
	From input $\overline{OE}$ to output B	–40°C to 85°C	0.5	22	0.5	19	0.5	17	0.5	17	
		–40°C to 125°C	0.5	23	0.5	20	0.5	18	0.5	18	

# SN74AXC8T245

SCES875B –MARCH 2018–REVISED AUGUST 2018

www.ti.com

## 6.10 Switching Characteristics, $V_{CCA} = 1.5\text{ V}$

See [Figure 1](#) and [Figure 2](#) for test circuit and loading conditions. See [Figure 3](#) and [Figure 4](#) for measurement waveforms.

PARAMETER	TEST CONDITIONS		B-PORT SUPPLY VOLTAGE ( $V_{CCB}$ )								UNIT
			0.7 V $\pm$ 0.05 V		0.8 V $\pm$ 0.04 V		0.9 V $\pm$ 0.045 V		1.2 V $\pm$ 0.1 V		
			MIN	MAX	MIN	MAX	MIN	MAX	MIN	MAX	
$t_{pd}$ Propagation delay	From input A to output B	-40°C to 85°C	0.5	84	0.5	42	0.5	28	0.5	13	ns
		-40°C to 125°C	0.5	84	0.5	42	0.5	28	0.5	13	
	From input B to output A	-40°C to 85°C	0.5	46	0.5	26	0.5	17	0.5	10	
		-40°C to 125°C	0.5	46	0.5	26	0.5	17	0.5	10	
$t_{dis}$ Disable time	From input $\overline{OE}$ to output A	-40°C to 85°C	0.5	34	0.5	34	0.5	34	0.5	34	ns
		-40°C to 125°C	0.5	37	0.5	37	0.5	37	0.5	37	
	From input $\overline{OE}$ to output B	-40°C to 85°C	0.5	115	0.5	89	0.5	80	0.5	85	
		-40°C to 125°C	0.5	117	0.5	91	0.5	83	0.5	89	
$t_{en}$ Enable time	From input $\overline{OE}$ to output A	-40°C to 85°C	0.5	21	0.5	21	0.5	21	0.5	21	ns
		-40°C to 125°C	0.5	23	0.5	23	0.5	23	0.5	23	
	From input $\overline{OE}$ to output B	-40°C to 85°C	0.5	159	0.5	90	0.5	55	0.5	24	
		-40°C to 125°C	0.5	159	0.5	90	0.5	55	0.5	25	

PARAMETER	TEST CONDITIONS		B-PORT SUPPLY VOLTAGE ( $V_{CCB}$ )								UNIT
			1.5 V $\pm$ 0.1 V		1.8 V $\pm$ 0.15 V		2.5 V $\pm$ 0.2 V		3.3 V $\pm$ 0.3 V		
			MIN	MAX	MIN	MAX	MIN	MAX	MIN	MAX	
$t_{pd}$ Propagation delay	From input A to output B	-40°C to 85°C	0.5	9	0.5	7	0.5	6	0.5	5	ns
		-40°C to 125°C	0.5	9	0.5	7	0.5	6	0.5	6	
	From input B to output A	-40°C to 85°C	0.5	9	0.5	7	0.5	6	0.5	5	
		-40°C to 125°C	0.5	9	0.5	8	0.5	6	0.5	5	
$t_{dis}$ Disable time	From input $\overline{OE}$ to output A	-40°C to 85°C	0.5	34	0.5	34	0.5	34	0.5	34	ns
		-40°C to 125°C	0.5	37	0.5	37	0.5	37	0.5	37	
	From input $\overline{OE}$ to output B	-40°C to 85°C	0.5	35	0.5	31	0.5	28	0.5	25	
		-40°C to 125°C	0.5	38	0.5	34	0.5	31	0.5	27	
$t_{en}$ Enable time	From input $\overline{OE}$ to output A	-40°C to 85°C	0.5	21	0.5	21	0.5	21	0.5	21	ns
		-40°C to 125°C	0.5	23	0.5	23	0.5	23	0.5	23	
	From input $\overline{OE}$ to output B	-40°C to 85°C	0.5	17	0.5	15	0.5	12	0.5	11	
		-40°C to 125°C	0.5	18	0.5	15	0.5	13	0.5	12	

## 6.11 Switching Characteristics, $V_{CCA} = 1.8\text{ V}$

See [Figure 1](#) and [Figure 2](#) for test circuit and loading conditions. See [Figure 3](#) and [Figure 4](#) for measurement waveforms.

PARAMETER	TEST CONDITIONS		B-PORT SUPPLY VOLTAGE ( $V_{CCB}$ )								UNIT
			0.7 V $\pm$ 0.05 V		0.8 V $\pm$ 0.04 V		0.9 V $\pm$ 0.045 V		1.2 V $\pm$ 0.1 V		
			MIN	MAX	MIN	MAX	MIN	MAX	MIN	MAX	
$t_{pd}$ Propagation delay	From input A to output B	-40°C to 85°C	0.5	82	0.5	41	0.5	24	0.5	11	ns
		-40°C to 125°C	0.5	82	0.5	41	0.5	24	0.5	11	
	From input B to output A	-40°C to 85°C	0.5	49	0.5	25	0.5	15	0.5	9	
		-40°C to 125°C	0.5	49	0.5	25	0.5	15	0.5	9	
$t_{dis}$ Disable time	From input $\overline{OE}$ to output A	-40°C to 85°C	0.5	37	0.5	37	0.5	37	0.5	37	ns
		-40°C to 125°C	0.5	40	0.5	40	0.5	40	0.5	40	
	From input $\overline{OE}$ to output B	-40°C to 85°C	0.5	113	0.5	87	0.5	78	0.5	83	
		-40°C to 125°C	0.5	115	0.5	89	0.5	81	0.5	87	
$t_{en}$ Enable time	From input $\overline{OE}$ to output A	-40°C to 85°C	0.5	17	0.5	17	0.5	17	0.5	17	ns
		-40°C to 125°C	0.5	19	0.5	19	0.5	19	0.5	19	
	From input $\overline{OE}$ to output B	-40°C to 85°C	0.5	157	0.5	88	0.5	54	0.5	23	
		-40°C to 125°C	0.5	157	0.5	88	0.5	54	0.5	23	

PARAMETER	TEST CONDITIONS		B-PORT SUPPLY VOLTAGE ( $V_{CCB}$ )								UNIT
			1.5 V $\pm$ 0.1 V		1.8 V $\pm$ 0.15 V		2.5 V $\pm$ 0.2 V		3.3 V $\pm$ 0.3 V		
			MIN	MAX	MIN	MAX	MIN	MAX	MIN	MAX	
$t_{pd}$ Propagation delay	From input A to output B	-40°C to 85°C	0.5	8	0.5	6	0.5	5	0.5	5	ns
		-40°C to 125°C	0.5	8	0.5	7	0.5	6	0.5	5	
	From input B to output A	-40°C to 85°C	0.5	7	0.5	6	0.5	5	0.5	4	
		-40°C to 125°C	0.5	7	0.5	7	0.5	5	0.5	4	
$t_{dis}$ Disable time	From input $\overline{OE}$ to output A	-40°C to 85°C	0.5	37	0.5	37	0.5	37	0.5	37	ns
		-40°C to 125°C	0.5	40	0.5	40	0.5	40	0.5	40	
	From input $\overline{OE}$ to output B	-40°C to 85°C	0.5	33	0.5	30	0.5	27	0.5	57	
		-40°C to 125°C	0.5	36	0.5	33	0.5	29	0.5	60	
$t_{en}$ Enable time	From input $\overline{OE}$ to output A	-40°C to 85°C	0.5	17	0.5	17	0.5	17	0.5	17	ns
		-40°C to 125°C	0.5	19	0.5	19	0.5	19	0.5	19	
	From input $\overline{OE}$ to output B	-40°C to 85°C	0.5	15	0.5	13	0.5	10	0.5	9	
		-40°C to 125°C	0.5	16	0.5	14	0.5	11	0.5	10	

## 6.12 Switching Characteristics, $V_{CCA} = 2.5\text{ V}$

See [Figure 1](#) and [Figure 2](#) for test circuit and loading conditions. See [Figure 3](#) and [Figure 4](#) for measurement waveforms.

PARAMETER	TEST CONDITIONS		B-PORT SUPPLY VOLTAGE ( $V_{CCB}$ )								UNIT
			0.7 V $\pm$ 0.05 V		0.8 V $\pm$ 0.04 V		0.9 V $\pm$ 0.045 V		1.2 V $\pm$ 0.1 V		
			MIN	MAX	MIN	MAX	MIN	MAX	MIN	MAX	
$t_{pd}$ Propagation delay	From input A to output B	-40°C to 85°C	0.5	81	0.5	40	0.5	22	0.5	8	ns
		-40°C to 125°C	0.5	81	0.5	40	0.5	22	0.5	8	
	From input B to output A	-40°C to 85°C	0.5	61	0.5	25	0.5	14	0.5	7	
		-40°C to 125°C	0.5	61	0.5	25	0.5	14	0.5	7	
$t_{dis}$ Disable time	From input $\overline{OE}$ to output A	-40°C to 85°C	0.5	25	0.5	25	0.5	25	0.5	25	ns
		-40°C to 125°C	0.5	28	0.5	28	0.5	28	0.5	28	
	From input $\overline{OE}$ to output B	-40°C to 85°C	0.5	111	0.5	85	0.5	76	0.5	81	
		-40°C to 125°C	0.5	113	0.5	87	0.5	78	0.5	84	
$t_{en}$ Enable time	From input $\overline{OE}$ to output A	-40°C to 85°C	0.5	11	0.5	11	0.5	11	0.5	11	ns
		-40°C to 125°C	0.5	12	0.5	12	0.5	12	0.5	12	
	From input $\overline{OE}$ to output B	-40°C to 85°C	0.5	155	0.5	86	0.5	52	0.5	21	
		-40°C to 125°C	0.5	155	0.5	86	0.5	52	0.5	21	

PARAMETER	TEST CONDITIONS		B-PORT SUPPLY VOLTAGE ( $V_{CCB}$ )								UNIT
			1.5 V $\pm$ 0.1 V		1.8 V $\pm$ 0.15 V		2.5 V $\pm$ 0.2 V		3.3 V $\pm$ 0.3 V		
			MIN	MAX	MIN	MAX	MIN	MAX	MIN	MAX	
$t_{pd}$ Propagation delay	From input A to output B	-40°C to 85°C	0.5	6	0.5	5	0.5	4	0.5	4	ns
		-40°C to 125°C	0.5	6	0.5	5	0.5	5	0.5	4	
	From input B to output A	-40°C to 85°C	0.5	6	0.5	5	0.5	4	0.5	4	
		-40°C to 125°C	0.5	6	0.5	5	0.5	5	0.5	4	
$t_{dis}$ Disable time	From input $\overline{OE}$ to output A	-40°C to 85°C	0.5	25	0.5	25	0.5	25	0.5	25	ns
		-40°C to 125°C	0.5	28	0.5	28	0.5	28	0.5	28	
	From input $\overline{OE}$ to output B	-40°C to 85°C	0.5	31	0.5	28	0.5	25	0.5	23	
		-40°C to 125°C	0.5	34	0.5	31	0.5	28	0.5	25	
$t_{en}$ Enable time	From input $\overline{OE}$ to output A	-40°C to 85°C	0.5	11	0.5	11	0.5	11	0.5	11	ns
		-40°C to 125°C	0.5	12	0.5	12	0.5	12	0.5	12	
	From input $\overline{OE}$ to output B	-40°C to 85°C	0.5	14	0.5	11	0.5	9	0.5	7	
		-40°C to 125°C	0.5	14	0.5	12	0.5	9	0.5	8	

### 6.13 Switching Characteristics, $V_{CCA} = 3.3\text{ V}$

See [Figure 1](#) and [Figure 2](#) for test circuit and loading conditions. See [Figure 3](#) and [Figure 4](#) for measurement waveforms.

PARAMETER	TEST CONDITIONS		B-PORT SUPPLY VOLTAGE ( $V_{CCB}$ )								UNIT
			0.7 V $\pm$ 0.05 V		0.8 V $\pm$ 0.04 V		0.9 V $\pm$ 0.045 V		1.2 V $\pm$ 0.1 V		
			MIN	MAX	MIN	MAX	MIN	MAX	MIN	MAX	
$t_{pd}$ Propagation delay	From input A to output B	-40°C to 85°C	0.5	81	0.5	40	0.5	22	0.5	7	ns
		-40°C to 125°C	0.5	81	0.5	40	0.5	22	0.5	7	
	From input B to output A	-40°C to 85°C	0.5	142	0.5	35	0.5	17	0.5	7	
		-40°C to 125°C	0.5	142	0.5	35	0.5	17	0.5	8	
$t_{dis}$ Disable time	From input $\overline{OE}$ to output A	-40°C to 85°C	0.5	22	0.5	22	0.5	22	0.5	22	ns
		-40°C to 125°C	0.5	24	0.5	24	0.5	24	0.5	24	
	From input $\overline{OE}$ to output B	-40°C to 85°C	0.5	111	0.5	84	0.5	75	0.5	80	
		-40°C to 125°C	0.5	113	0.5	86	0.5	78	0.5	83	
$t_{en}$ Enable time	From input $\overline{OE}$ to output A	-40°C to 85°C	0.5	9	0.5	9	0.5	9	0.5	9	ns
		-40°C to 125°C	0.5	10	0.5	10	0.5	10	0.5	10	
	From input $\overline{OE}$ to output B	-40°C to 85°C	0.5	154	0.5	86	0.5	51	0.5	20	
		-40°C to 125°C	0.5	154	0.5	86	0.5	51	0.5	20	

PARAMETER	TEST CONDITIONS		B-PORT SUPPLY VOLTAGE ( $V_{CCB}$ )								UNIT
			1.5 V $\pm$ 0.1 V		1.8 V $\pm$ 0.15 V		2.5 V $\pm$ 0.2 V		3.3 V $\pm$ 0.3 V		
			MIN	MAX	MIN	MAX	MIN	MAX	MIN	MAX	
$t_{pd}$ Propagation delay	From input A to output B	-40°C to 85°C	0.5	5	0.5	4	0.5	4	0.5	4	ns
		-40°C to 125°C	0.5	5	0.5	4	0.5	4	0.5	4	
	From input B to output A	-40°C to 85°C	0.5	5	0.5	5	0.5	4	0.5	4	
		-40°C to 125°C	0.5	6	0.5	5	0.5	4	0.5	4	
$t_{dis}$ Disable time	From input $\overline{OE}$ to output A	-40°C to 85°C	0.5	22	0.5	22	0.5	22	0.5	22	ns
		-40°C to 125°C	0.5	24	0.5	24	0.5	24	0.5	24	
	From input $\overline{OE}$ to output B	-40°C to 85°C	0.5	30	0.5	27	0.5	25	0.5	23	
		-40°C to 125°C	0.5	33	0.5	30	0.5	27	0.5	25	
$t_{en}$ Enable time	From input $\overline{OE}$ to output A	-40°C to 85°C	0.5	9	0.5	9	0.5	9	0.5	9	ns
		-40°C to 125°C	0.5	10	0.5	10	0.5	10	0.5	10	
	From input $\overline{OE}$ to output B	-40°C to 85°C	0.5	13	0.5	10	0.5	8	0.5	7	
		-40°C to 125°C	0.5	14	0.5	11	0.5	8	0.5	7	

**6.14 Operating Characteristics:  $T_A = 25^\circ\text{C}$** 

PARAMETER	TEST CONDITIONS	MIN	TYP	MAX	UNIT
$C_{pdA}$ Power dissipation capacitance per transceiver (A to B: outputs enabled)	$C_L = 0$ , $R_L = \text{Open}$ $f = 1 \text{ MHz}$ , $t_r = t_f = 1 \text{ ns}$	$V_{CCA} = V_{CCB} = 0.7 \text{ V}$		1.2	pF
		$V_{CCA} = V_{CCB} = 0.8 \text{ V}$		1.8	
		$V_{CCA} = V_{CCB} = 0.9 \text{ V}$		1.8	
		$V_{CCA} = V_{CCB} = 1.2 \text{ V}$		1.7	
		$V_{CCA} = V_{CCB} = 1.5 \text{ V}$		1.7	
		$V_{CCA} = V_{CCB} = 1.8 \text{ V}$		1.7	
		$V_{CCA} = V_{CCB} = 2.5 \text{ V}$		2	
		$V_{CCA} = V_{CCB} = 3.3 \text{ V}$		2.5	
$C_{pdA}$ Power dissipation capacitance per transceiver (A to B: outputs disabled)	$C_L = 0$ , $R_L = \text{Open}$ $f = 1 \text{ MHz}$ , $t_r = t_f = 1 \text{ ns}$	$V_{CCA} = V_{CCB} = 0.7 \text{ V}$		1.1	pF
		$V_{CCA} = V_{CCB} = 0.8 \text{ V}$		1.8	
		$V_{CCA} = V_{CCB} = 0.9 \text{ V}$		1.8	
		$V_{CCA} = V_{CCB} = 1.2 \text{ V}$		1.7	
		$V_{CCA} = V_{CCB} = 1.5 \text{ V}$		1.7	
		$V_{CCA} = V_{CCB} = 1.8 \text{ V}$		1.7	
		$V_{CCA} = V_{CCB} = 2.5 \text{ V}$		2	
		$V_{CCA} = V_{CCB} = 3.3 \text{ V}$		2.1	
$C_{pdA}$ Power dissipation capacitance per transceiver (B to A: outputs enabled)	$C_L = 0$ , $R_L = \text{Open}$ $f = 1 \text{ MHz}$ , $t_r = t_f = 1 \text{ ns}$	$V_{CCA} = V_{CCB} = 0.7 \text{ V}$		9.3	pF
		$V_{CCA} = V_{CCB} = 0.8 \text{ V}$		11.8	
		$V_{CCA} = V_{CCB} = 0.9 \text{ V}$		11.8	
		$V_{CCA} = V_{CCB} = 1.2 \text{ V}$		12	
		$V_{CCA} = V_{CCB} = 1.5 \text{ V}$		12.2	
		$V_{CCA} = V_{CCB} = 1.8 \text{ V}$		13	
		$V_{CCA} = V_{CCB} = 2.5 \text{ V}$		16.4	
		$V_{CCA} = V_{CCB} = 3.3 \text{ V}$		18.1	
$C_{pdA}$ Power dissipation capacitance per transceiver (B to A: outputs disabled)	$C_L = 0$ , $R_L = \text{Open}$ $f = 1 \text{ MHz}$ , $t_r = t_f = 1 \text{ ns}$	$V_{CCA} = V_{CCB} = 0.7 \text{ V}$		2.6	pF
		$V_{CCA} = V_{CCB} = 0.8 \text{ V}$		1.2	
		$V_{CCA} = V_{CCB} = 0.9 \text{ V}$		1.1	
		$V_{CCA} = V_{CCB} = 1.2 \text{ V}$		1.2	
		$V_{CCA} = V_{CCB} = 1.5 \text{ V}$		1.2	
		$V_{CCA} = V_{CCB} = 1.8 \text{ V}$		1.3	
		$V_{CCA} = V_{CCB} = 2.5 \text{ V}$		1.6	
		$V_{CCA} = V_{CCB} = 3.3 \text{ V}$		3.9	



**Operating Characteristics:  $T_A = 25^\circ\text{C}$  (continued)**

PARAMETER	TEST CONDITIONS	MIN	TYP	MAX	UNIT
$C_{pdB}$ Power dissipation capacitance per transceiver (A to B: outputs enabled)	$C_L = 0$ , $R_L = \text{Open}$ $f = 1 \text{ MHz}$ , $t_r = t_f = 1 \text{ ns}$	$V_{CCA} = V_{CCB} = 0.7 \text{ V}$	9.3		pF
		$V_{CCA} = V_{CCB} = 0.8 \text{ V}$	11.7		
		$V_{CCA} = V_{CCB} = 0.9 \text{ V}$	11.8		
		$V_{CCA} = V_{CCB} = 1.2 \text{ V}$	11.9		
		$V_{CCA} = V_{CCB} = 1.5 \text{ V}$	12.2		
		$V_{CCA} = V_{CCB} = 1.8 \text{ V}$	12.9		
		$V_{CCA} = V_{CCB} = 2.5 \text{ V}$	16.3		
		$V_{CCA} = V_{CCB} = 3.3 \text{ V}$	18		
$C_{pdB}$ Power dissipation capacitance per transceiver (A to B: outputs disabled)	$C_L = 0$ , $R_L = \text{Open}$ $f = 1 \text{ MHz}$ , $t_r = t_f = 1 \text{ ns}$	$V_{CCA} = V_{CCB} = 0.7 \text{ V}$	2.6		pF
		$V_{CCA} = V_{CCB} = 0.8 \text{ V}$	11.7		
		$V_{CCA} = V_{CCB} = 0.9 \text{ V}$	11.8		
		$V_{CCA} = V_{CCB} = 1.2 \text{ V}$	11.9		
		$V_{CCA} = V_{CCB} = 1.5 \text{ V}$	12.2		
		$V_{CCA} = V_{CCB} = 1.8 \text{ V}$	12.9		
		$V_{CCA} = V_{CCB} = 2.5 \text{ V}$	16.3		
		$V_{CCA} = V_{CCB} = 3.3 \text{ V}$	3.9		
$C_{pdB}$ Power dissipation capacitance per transceiver (B to A: outputs enabled)	$C_L = 0$ , $R_L = \text{Open}$ $f = 1 \text{ MHz}$ , $t_r = t_f = 1 \text{ ns}$	$V_{CCA} = V_{CCB} = 0.7 \text{ V}$	1.2		pF
		$V_{CCA} = V_{CCB} = 0.8 \text{ V}$	1.8		
		$V_{CCA} = V_{CCB} = 0.9 \text{ V}$	1.8		
		$V_{CCA} = V_{CCB} = 1.2 \text{ V}$	1.7		
		$V_{CCA} = V_{CCB} = 1.5 \text{ V}$	1.7		
		$V_{CCA} = V_{CCB} = 1.8 \text{ V}$	1.7		
		$V_{CCA} = V_{CCB} = 2.5 \text{ V}$	2		
		$V_{CCA} = V_{CCB} = 3.3 \text{ V}$	2.5		
$C_{pdB}$ Power dissipation capacitance per transceiver (B to A: outputs disabled)	$C_L = 0$ , $R_L = \text{Open}$ $f = 1 \text{ MHz}$ , $t_r = t_f = 1 \text{ ns}$	$V_{CCA} = V_{CCB} = 0.7 \text{ V}$	1.1		pF
		$V_{CCA} = V_{CCB} = 0.8 \text{ V}$	1.8		
		$V_{CCA} = V_{CCB} = 0.9 \text{ V}$	1.8		
		$V_{CCA} = V_{CCB} = 1.2 \text{ V}$	1.7		
		$V_{CCA} = V_{CCB} = 1.5 \text{ V}$	1.7		
		$V_{CCA} = V_{CCB} = 1.8 \text{ V}$	1.7		
		$V_{CCA} = V_{CCB} = 2.5 \text{ V}$	2		
		$V_{CCA} = V_{CCB} = 3.3 \text{ V}$	2.1		

## 7 Parameter Measurement Information

Unless otherwise noted, all input pulses are supplied by generators having the following characteristics:

- $f = 1$  MHz
- $Z_0 = 50 \Omega$
- $dv / dt \leq 1$  ns/V

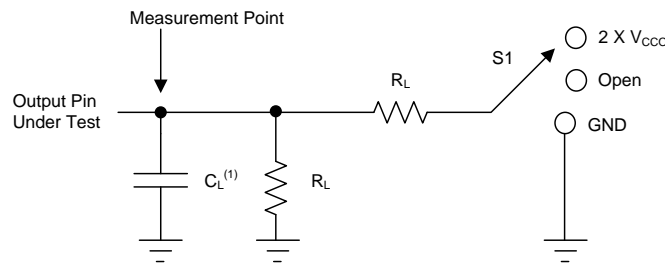

- (1)  $C_L$  includes probe and jig capacitance.

Figure 1. Load Circuit

Parameter	$V_{CCO}$	$R_L$	$C_L$	S1	$V_{TP}$
$t_{pd}$	1.1 V - 3.6 V	2 k $\Omega$	15 pF	Open	N/A
	0.65 V - 0.95 V	20 k $\Omega$	15 pF	Open	N/A
$t_{en}^{(1)}, t_{dis}^{(1)}$	3 V - 3.6 V	2 k $\Omega$	15 pF	2 X $V_{CCO}$	0.3 V
	1.65 V - 2.7 V	2 k $\Omega$	15 pF	2 X $V_{CCO}$	0.15 V
	1.1 V - 1.6 V	2 k $\Omega$	15 pF	2 X $V_{CCO}$	0.1 V
	0.65 V - 0.95 V	20 k $\Omega$	15 pF	2 X $V_{CCO}$	0.1 V
$t_{en}^{(2)}, t_{dis}^{(2)}$	3 V - 3.6 V	2 k $\Omega$	15 pF	GND	0.3 V
	1.65 V - 2.7 V	2 k $\Omega$	15 pF	GND	0.15 V
	1.1 V - 1.6 V	2 k $\Omega$	15 pF	GND	0.1 V
	0.65 V - 0.95 V	20 k $\Omega$	15 pF	GND	0.1 V

- (1) Output waveform on the conditions that input is driven to a valid Logic Low.  
 (2) Output waveform on the condition that input is driven to a valid Logic High.

Figure 2. Load Circuit Conditions

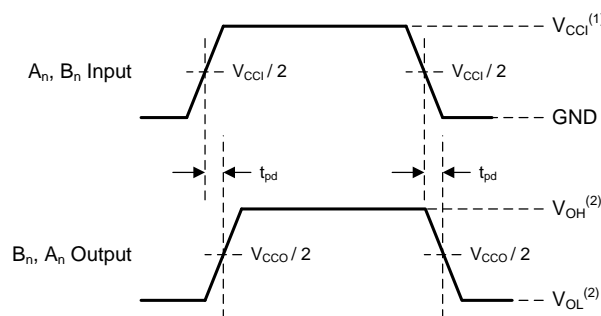

- (1)  $V_{CCI}$  is the supply pin associated with the input port.  
 (2)  $V_{OH}$  and  $V_{OL}$  are typical output voltage levels with specified  $R_L$ ,  $C_L$ , and  $S_1$ .

Figure 3. Propagation Delay

**Parameter Measurement Information (continued)**

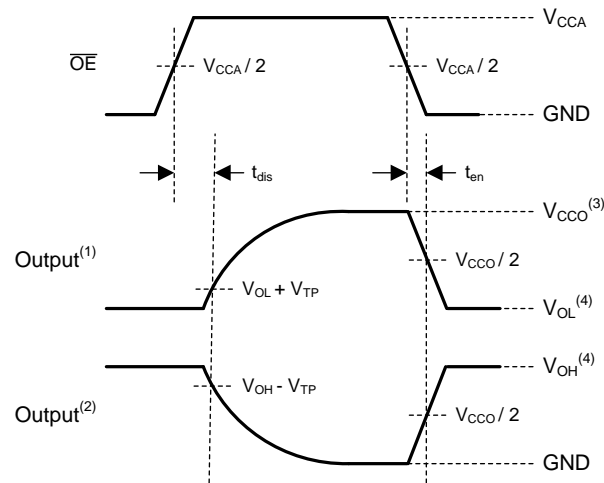

- (1) Output waveform on the condition that input is driven to a valid Logic Low.
- (2) Output waveform on the condition that input is driven to a valid Logic High.
- (3)  $V_{CCO}$  is the supply pin associated with the output port.
- (4)  $V_{OH}$  and  $V_{OL}$  are typical output voltage levels with specified  $R_L$ ,  $C_L$ , and  $S_1$ .

**Figure 4. Enable Time And Disable Time**

## 8 Detailed Description

### 8.1 Overview

The SN74AXC8T245 device is an 8-bit, dual-supply non-inverting transceiver with bidirectional voltage level translation. The I/O pins labeled with A and the control pins (DIR1, DIR2, and  $\overline{OE}$ ) are supported by  $V_{CCA}$ , and the I/O pins labeled with B are supported by  $V_{CCB}$ . Both the A port and the B port are able to accept I/O voltages ranging from 0.65 V to 3.6 V.

### 8.2 Functional Block Diagram

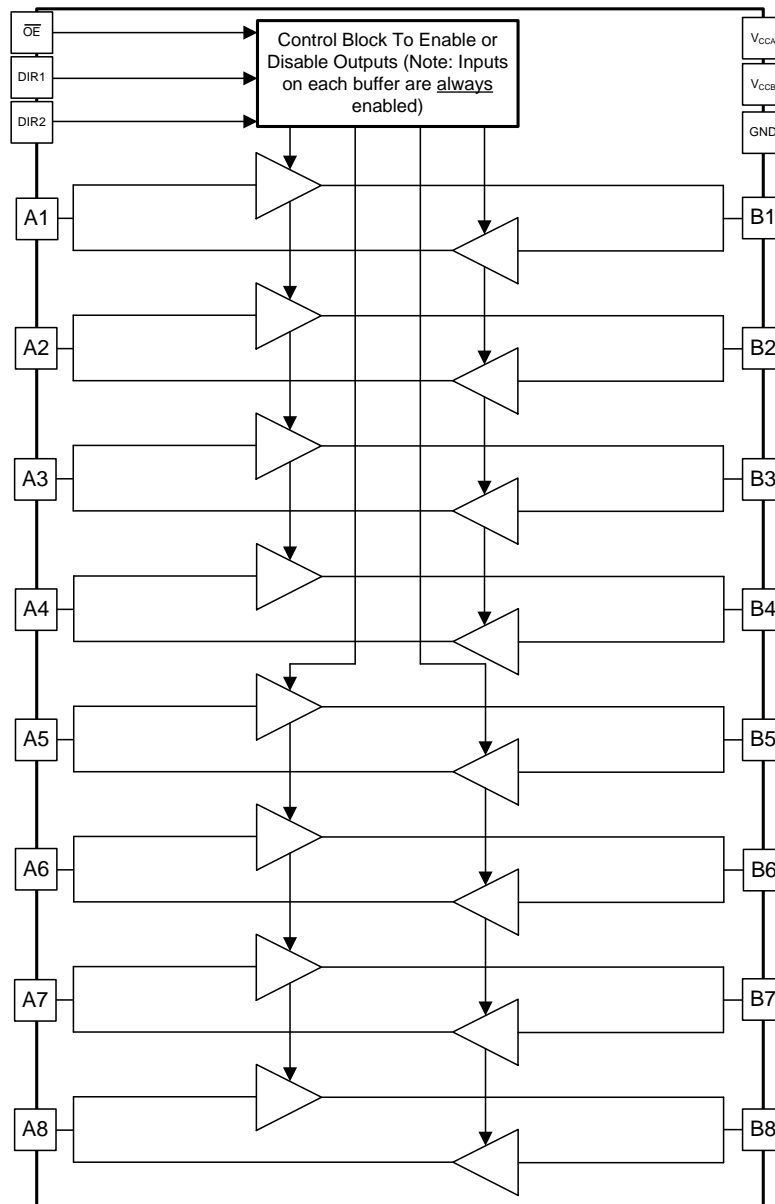

## 8.3 Feature Description

### 8.3.1 Up-Translation and Down-Translation From 0.65 V to 3.6 V

Both supply pins are configured from 0.65 V to 3.6 V, which makes the device suitable for translating between any of the low voltage nodes (0.7 V, 0.8 V, 0.9 V, 1.2 V, 1.8 V, 2.5 V, and 3.3 V).

### 8.3.2 Multiple Direction Control Pins

Two control pins are used to configure the 8 data I/Os. I/O channels 1 through 4 are grouped together and I/O channels 5 through 8 are banked together. The benefit of this is to permit simultaneous up-translation and down-translation within one device. This eliminates the need for multiple devices, where each device can only provide up-translation or down-translation sequentially. Simultaneous up and down translation is supported when both  $V_{CCA}$  and  $V_{CCB}$  are at least 1.40 V.

### 8.3.3 $I_{off}$ Supports Partial-Power-Down Mode Operation

This feature is to limit the leakage current of an I/O pin being driven to a voltage as large as 3.6 V while having its corresponding power supply rail powered down. This is represented by the  $I_{off}$  parameter in the [Electrical Characteristics](#) table.

## 8.4 Device Functional Modes

All control inputs are referenced to  $V_{CCA}$  and must be driven to a valid Logic High or Logic Low (that is, not floating) to assure proper device operation and to prevent excessive power consumption. [Table 1](#) summarizes the possible modes of device operation based on the configuration of the control inputs.

**Table 1. Function Table<sup>(1)</sup>**

CONTROL INPUTS			Signal Direction	
$\overline{OE}$	DIR1	DIR2	Bits 1:4	Bits 5:8
H	X	X	Disabled (Hi-Z)	
L	L	L	B to A	
L	L	H	B to A	A to B
L	H	L	A to B	
L	H	H	A to B	B to A

(1) Input circuits of the data I/Os are always active and must be driven to a valid logic level.

## 9 Application and Implementation

### NOTE

Information in the following applications sections is not part of the TI component specification, and TI does not warrant its accuracy or completeness. TI's customers are responsible for determining suitability of components for their purposes. Customers should validate and test their design implementation to confirm system functionality.

### 9.1 Application Information

The SN74AXC8T245 device can be used in level-translation applications for interfacing devices or systems operating at different voltage nodes. [Figure 5](#) depicts an application in which the SN74AXC8T245 device is up-translating a 0.7 V input to a 3.3 V output to interface between a system controller and a peripheral device.

### 9.2 Typical Application

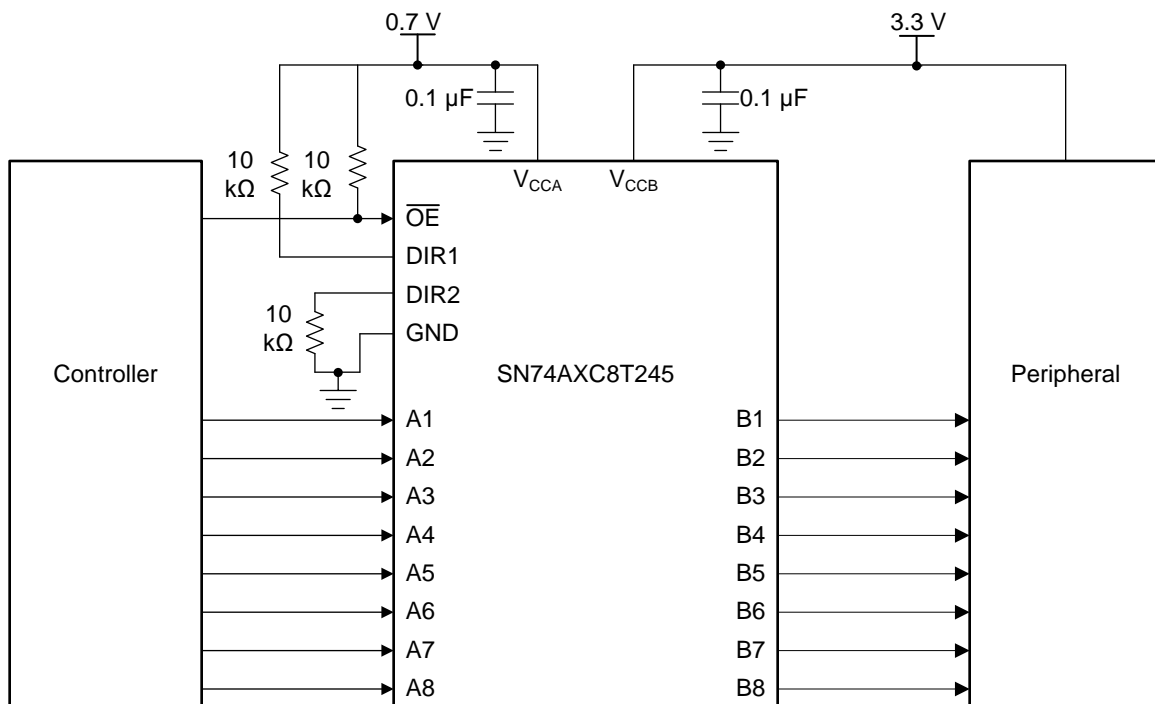

**Figure 5. Typical Application Schematic**

## Typical Application (continued)

### 9.2.1 Design Requirements

For this design example, use the parameters listed in [Table 2](#).

**Table 2. Design Parameters**

DESIGN PARAMETERS	EXAMPLE VALUE
Input voltage range	0.65 V to 3.6 V
Output voltage range	0.65 V to 3.6 V

### 9.2.2 Detailed Design Procedure

To begin the design process, determine the following:

- Input voltage range
  - Use the supply voltage of the device that is driving the SN74AXC8T245 device to determine the input voltage range. For a valid logic high the value must exceed the  $V_{IH}$  of the input port. For a valid logic low the value must be less than the  $V_{IL}$  of the input port.
- Output voltage range
  - Use the supply voltage of the device that the SN74AXC8T245 device is driving to determine the output voltage range.

### 9.2.3 Application Curve

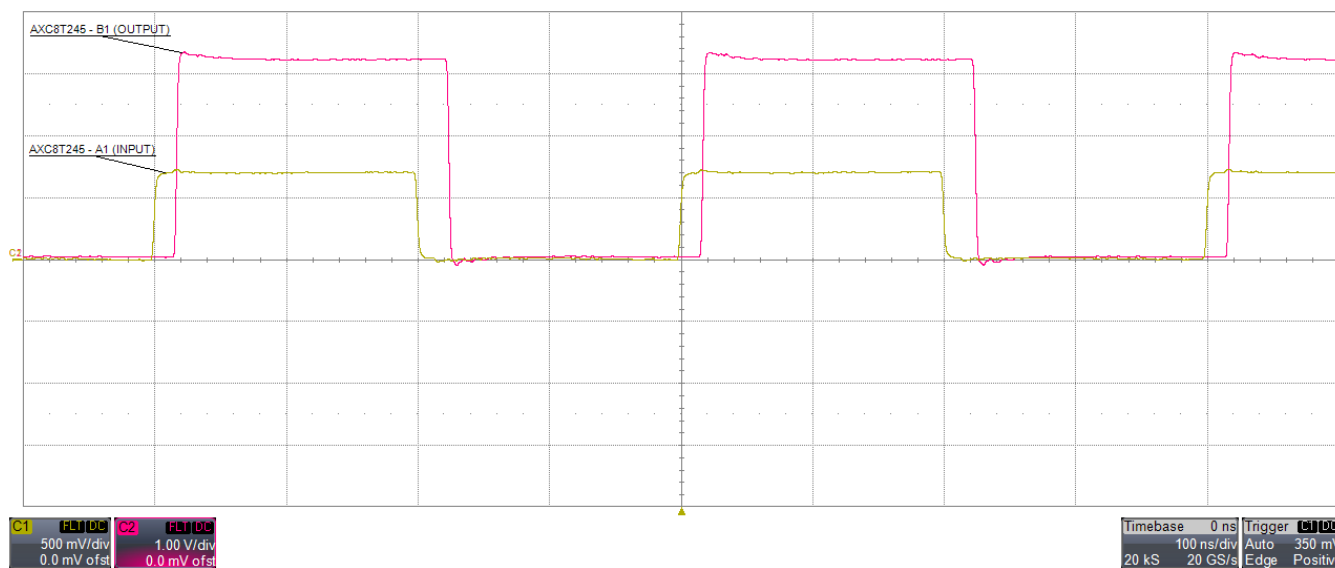

**Figure 6. Translation Up (0.7 V to 3.3 V) at 2.5 MHz**

## 10 Power Supply Recommendations

Always apply a ground reference to the GND pins first. However, there are no additional requirements for power supply sequencing.

This device was designed with various power supply sequencing methods in mind to help prevent unintended triggering of downstream devices. For more information regarding the power up glitch performance of the AXC family of level translators, see the [Power Sequencing for AXC Family of Devices](#) application report.

## 11 Layout

### 11.1 Layout Guidelines

To assure reliability of the device, follow common printed-circuit board layout guidelines.

- Use bypass capacitors on power supplies.
- Use short trace lengths to avoid excessive loading.
- Place pads on the signal paths for loading capacitors or pullup resistors to help adjust rise and fall times of signals depending on the system requirements.

### 11.2 Layout Example

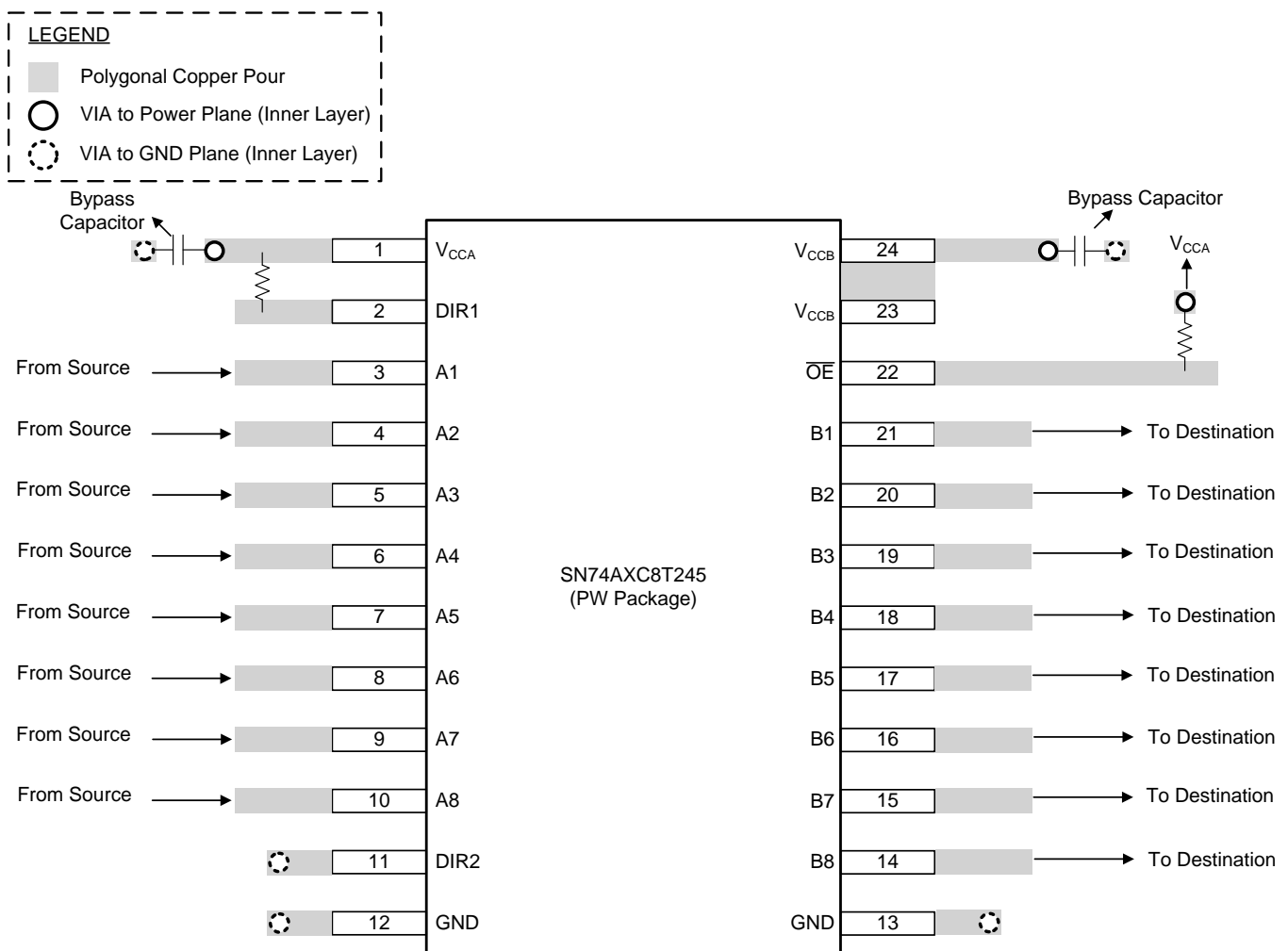

Figure 7. SN74AXC8T245 Device Layout Example



## 12 Device and Documentation Support

### 12.1 Documentation Support

#### 12.1.1 Related Documentation

For related documentation see the following:

- Texas Instruments, [Implications of Slow or Floating CMOS Inputs](#) application report
- Texas Instruments, [Power Sequencing for AXC Family of Devices](#) application report

### 12.2 Receiving Notification of Documentation Updates

To receive notification of documentation updates, navigate to the device product folder on ti.com. In the upper right corner, click on *Alert me* to register and receive a weekly digest of any product information that has changed. For change details, review the revision history included in any revised document.

### 12.3 Community Resources

The following links connect to TI community resources. Linked contents are provided "AS IS" by the respective contributors. They do not constitute TI specifications and do not necessarily reflect TI's views; see TI's [Terms of Use](#).

**TI E2E™ Online Community** *TI's Engineer-to-Engineer (E2E) Community*. Created to foster collaboration among engineers. At e2e.ti.com, you can ask questions, share knowledge, explore ideas and help solve problems with fellow engineers.

**Design Support** *TI's Design Support* Quickly find helpful E2E forums along with design support tools and contact information for technical support.

### 12.4 Trademarks

E2E is a trademark of Texas Instruments.  
All other trademarks are the property of their respective owners.

### 12.5 Electrostatic Discharge Caution



This integrated circuit can be damaged by ESD. Texas Instruments recommends that all integrated circuits be handled with appropriate precautions. Failure to observe proper handling and installation procedures can cause damage.

ESD damage can range from subtle performance degradation to complete device failure. Precision integrated circuits may be more susceptible to damage because very small parametric changes could cause the device not to meet its published specifications.

### 12.6 Glossary

[SLYZ022](#) — *TI Glossary*.

This glossary lists and explains terms, acronyms, and definitions.

## 13 Mechanical, Packaging, and Orderable Information

The following pages include mechanical, packaging, and orderable information. This information is the most current data available for the designated devices. This data is subject to change without notice and revision of this document. For browser-based versions of this data sheet, refer to the left-hand navigation.

**PACKAGING INFORMATION**

Orderable Device	Status (1)	Package Type	Package Drawing	Pins	Package Qty	Eco Plan (2)	Lead finish/ Ball material (6)	MSL Peak Temp (3)	Op Temp (°C)	Device Marking (4/5)	Samples
SN74AXC8T245PWR	ACTIVE	TSSOP	PW	24	2000	RoHS & Green	NIPDAU	Level-1-260C-UNLIM	-40 to 125	AX8T245	<a href="#">Samples</a>
SN74AXC8T245RHLR	ACTIVE	VQFN	RHL	24	3000	RoHS & Green	NIPDAU	Level-1-260C-UNLIM	-40 to 125	AX8T245	<a href="#">Samples</a>
SN74AXC8T245RJWR	ACTIVE	UQFN	RJW	24	3000	RoHS & Green	NIPDAUAG	Level-1-260C-UNLIM	-40 to 125	AX8T245	<a href="#">Samples</a>

(1) The marketing status values are defined as follows:

**ACTIVE:** Product device recommended for new designs.

**LIFEBUY:** TI has announced that the device will be discontinued, and a lifetime-buy period is in effect.

**NRND:** Not recommended for new designs. Device is in production to support existing customers, but TI does not recommend using this part in a new design.

**PREVIEW:** Device has been announced but is not in production. Samples may or may not be available.

**OBSELETE:** TI has discontinued the production of the device.

(2) **RoHS:** TI defines "RoHS" to mean semiconductor products that are compliant with the current EU RoHS requirements for all 10 RoHS substances, including the requirement that RoHS substance do not exceed 0.1% by weight in homogeneous materials. Where designed to be soldered at high temperatures, "RoHS" products are suitable for use in specified lead-free processes. TI may reference these types of products as "Pb-Free".

**RoHS Exempt:** TI defines "RoHS Exempt" to mean products that contain lead but are compliant with EU RoHS pursuant to a specific EU RoHS exemption.

**Green:** TI defines "Green" to mean the content of Chlorine (Cl) and Bromine (Br) based flame retardants meet JS709B low halogen requirements of <=1000ppm threshold. Antimony trioxide based flame retardants must also meet the <=1000ppm threshold requirement.

(3) MSL, Peak Temp. - The Moisture Sensitivity Level rating according to the JEDEC industry standard classifications, and peak solder temperature.

(4) There may be additional marking, which relates to the logo, the lot trace code information, or the environmental category on the device.

(5) Multiple Device Markings will be inside parentheses. Only one Device Marking contained in parentheses and separated by a "~" will appear on a device. If a line is indented then it is a continuation of the previous line and the two combined represent the entire Device Marking for that device.

(6) Lead finish/Ball material - Orderable Devices may have multiple material finish options. Finish options are separated by a vertical ruled line. Lead finish/Ball material values may wrap to two lines if the finish value exceeds the maximum column width.

**Important Information and Disclaimer:**The information provided on this page represents TI's knowledge and belief as of the date that it is provided. TI bases its knowledge and belief on information provided by third parties, and makes no representation or warranty as to the accuracy of such information. Efforts are underway to better integrate information from third parties. TI has taken and continues to take reasonable steps to provide representative and accurate information but may not have conducted destructive testing or chemical analysis on incoming materials and chemicals. TI and TI suppliers consider certain information to be proprietary, and thus CAS numbers and other limited information may not be available for release.

In no event shall TI's liability arising out of such information exceed the total purchase price of the TI part(s) at issue in this document sold by TI to Customer on an annual basis.

**OTHER QUALIFIED VERSIONS OF SN74AXC8T245 :**

- Automotive: [SN74AXC8T245-Q1](#)

NOTE: Qualified Version Definitions:

- Automotive - Q100 devices qualified for high-reliability automotive applications targeting zero defects

**TAPE AND REEL INFORMATION**

**QUADRANT ASSIGNMENTS FOR PIN 1 ORIENTATION IN TAPE**

\*All dimensions are nominal

Device	Package Type	Package Drawing	Pins	SPQ	Reel Diameter (mm)	Reel Width W1 (mm)	A0 (mm)	B0 (mm)	K0 (mm)	P1 (mm)	W (mm)	Pin1 Quadrant
SN74AXC8T245PWR	TSSOP	PW	24	2000	330.0	16.4	6.95	8.3	1.6	8.0	16.0	Q1
SN74AXC8T245RHLR	VQFN	RHL	24	3000	330.0	12.4	3.8	5.8	1.2	8.0	12.0	Q1
SN74AXC8T245RJWR	UQFN	RJW	24	3000	177.8	12.4	2.21	4.22	0.81	4.0	12.0	Q1

**TAPE AND REEL BOX DIMENSIONS**

\*All dimensions are nominal

Device	Package Type	Package Drawing	Pins	SPQ	Length (mm)	Width (mm)	Height (mm)
SN74AXC8T245PWR	TSSOP	PW	24	2000	356.0	356.0	35.0
SN74AXC8T245RHLR	VQFN	RHL	24	3000	367.0	367.0	35.0
SN74AXC8T245RJWR	UQFN	RJW	24	3000	183.0	183.0	20.0

PW0024A



# PACKAGE OUTLINE

TSSOP - 1.2 mm max height

SMALL OUTLINE PACKAGE

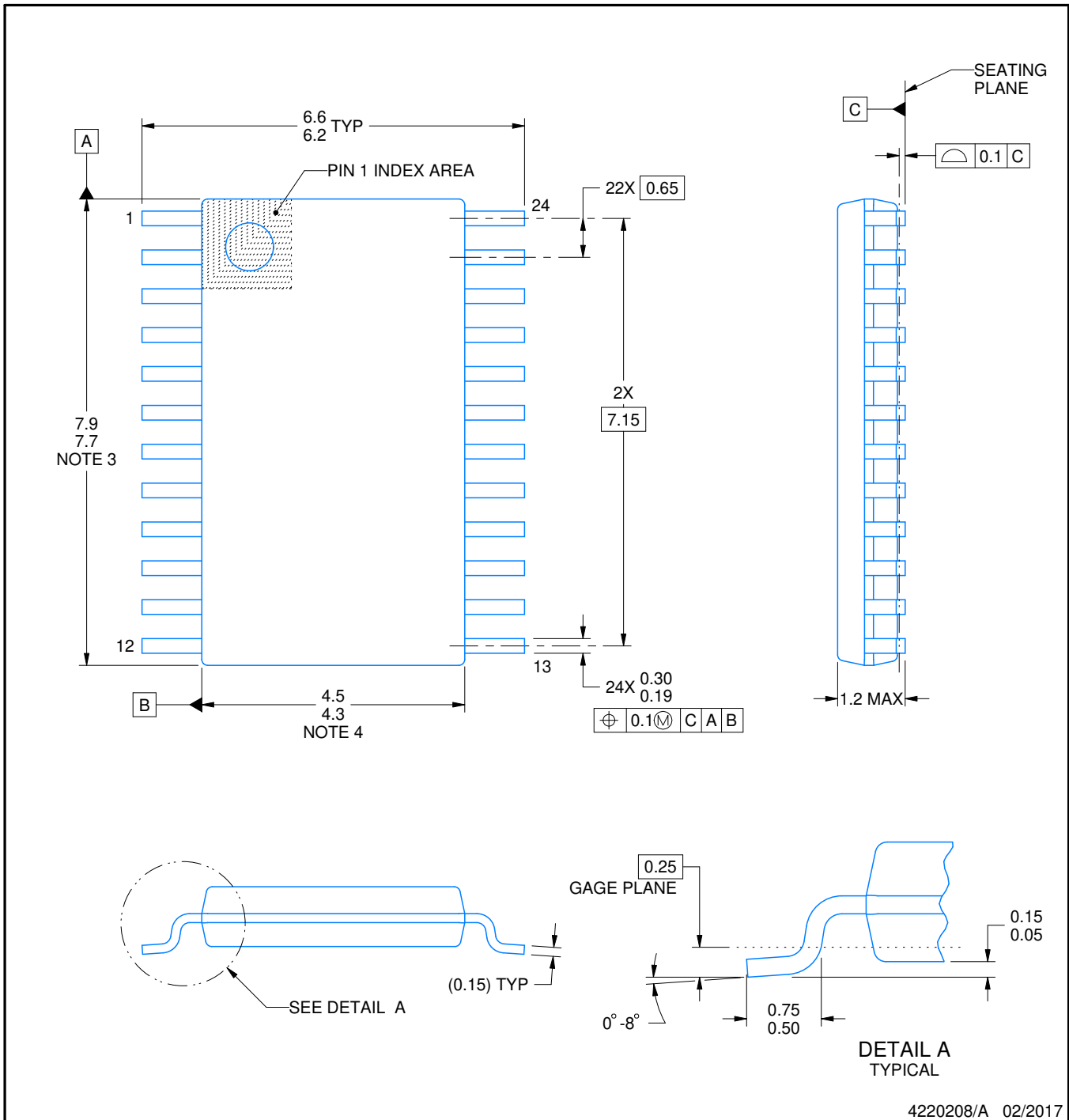

4220208/A 02/2017

## NOTES:

1. All linear dimensions are in millimeters. Any dimensions in parenthesis are for reference only. Dimensioning and tolerancing per ASME Y14.5M.
2. This drawing is subject to change without notice.
3. This dimension does not include mold flash, protrusions, or gate burrs. Mold flash, protrusions, or gate burrs shall not exceed 0.15 mm per side.
4. This dimension does not include interlead flash. Interlead flash shall not exceed 0.25 mm per side.
5. Reference JEDEC registration MO-153.

# EXAMPLE BOARD LAYOUT

PW0024A

TSSOP - 1.2 mm max height

SMALL OUTLINE PACKAGE

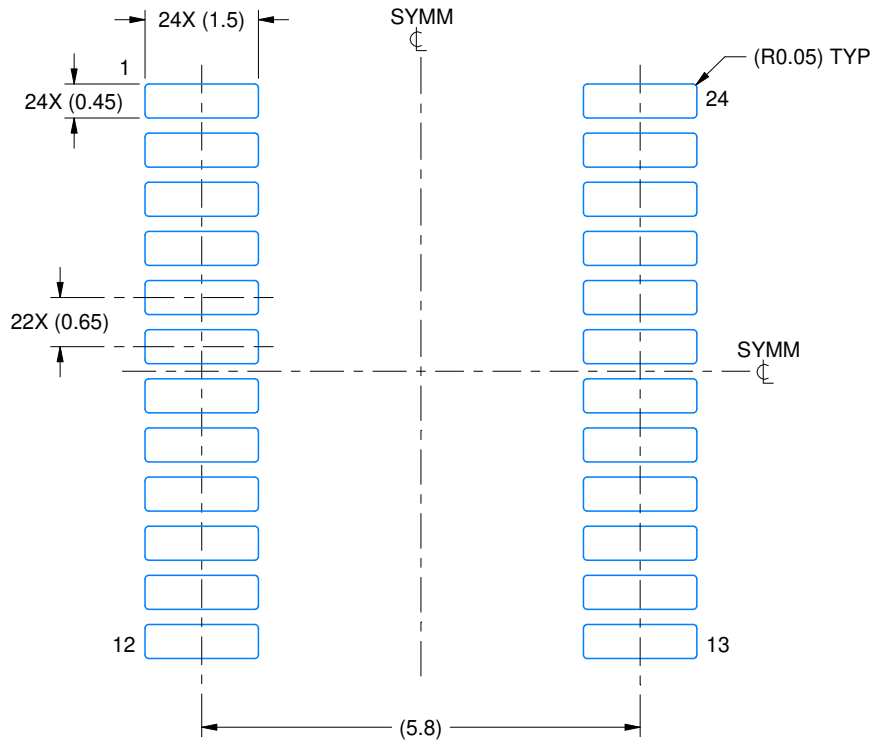

LAND PATTERN EXAMPLE  
EXPOSED METAL SHOWN  
SCALE: 10X

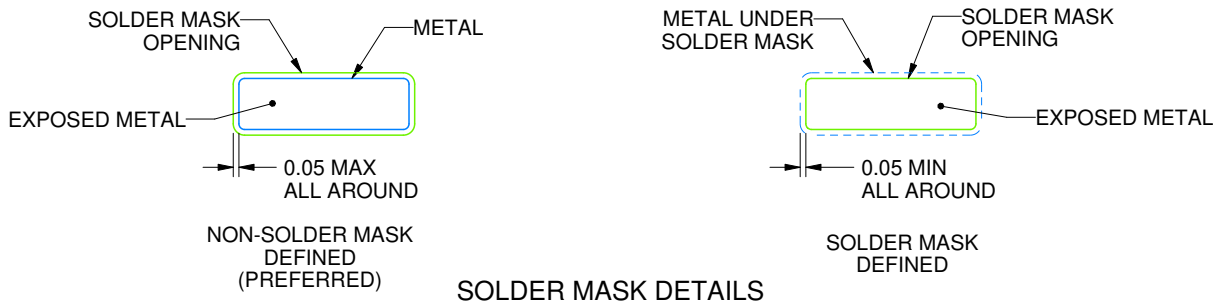

SOLDER MASK DETAILS

4220208/A 02/2017

NOTES: (continued)

- 6. Publication IPC-7351 may have alternate designs.
- 7. Solder mask tolerances between and around signal pads can vary based on board fabrication site.

# EXAMPLE STENCIL DESIGN

PW0024A

TSSOP - 1.2 mm max height

SMALL OUTLINE PACKAGE

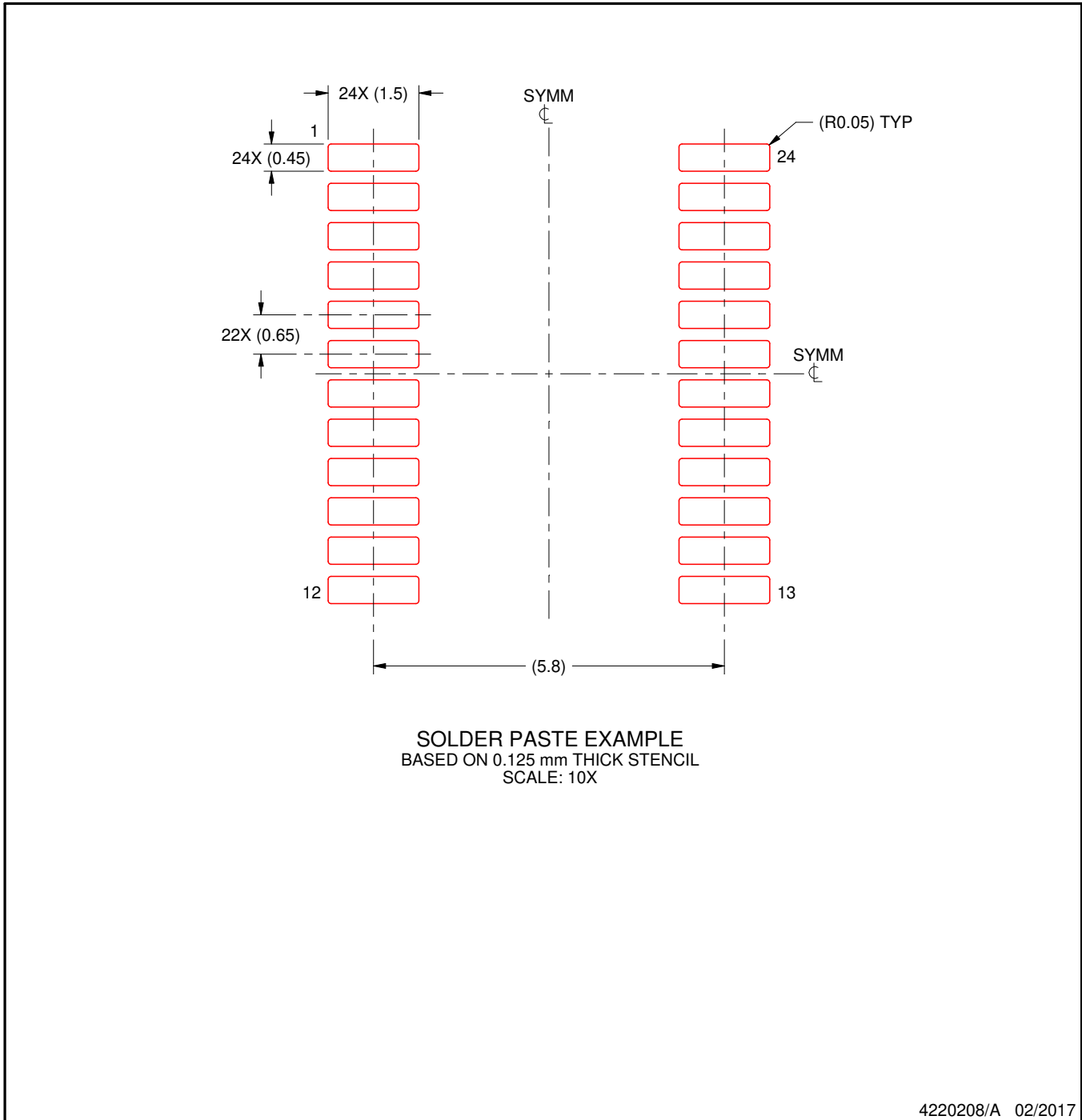

NOTES: (continued)

8. Laser cutting apertures with trapezoidal walls and rounded corners may offer better paste release. IPC-7525 may have alternate design recommendations.
9. Board assembly site may have different recommendations for stencil design.





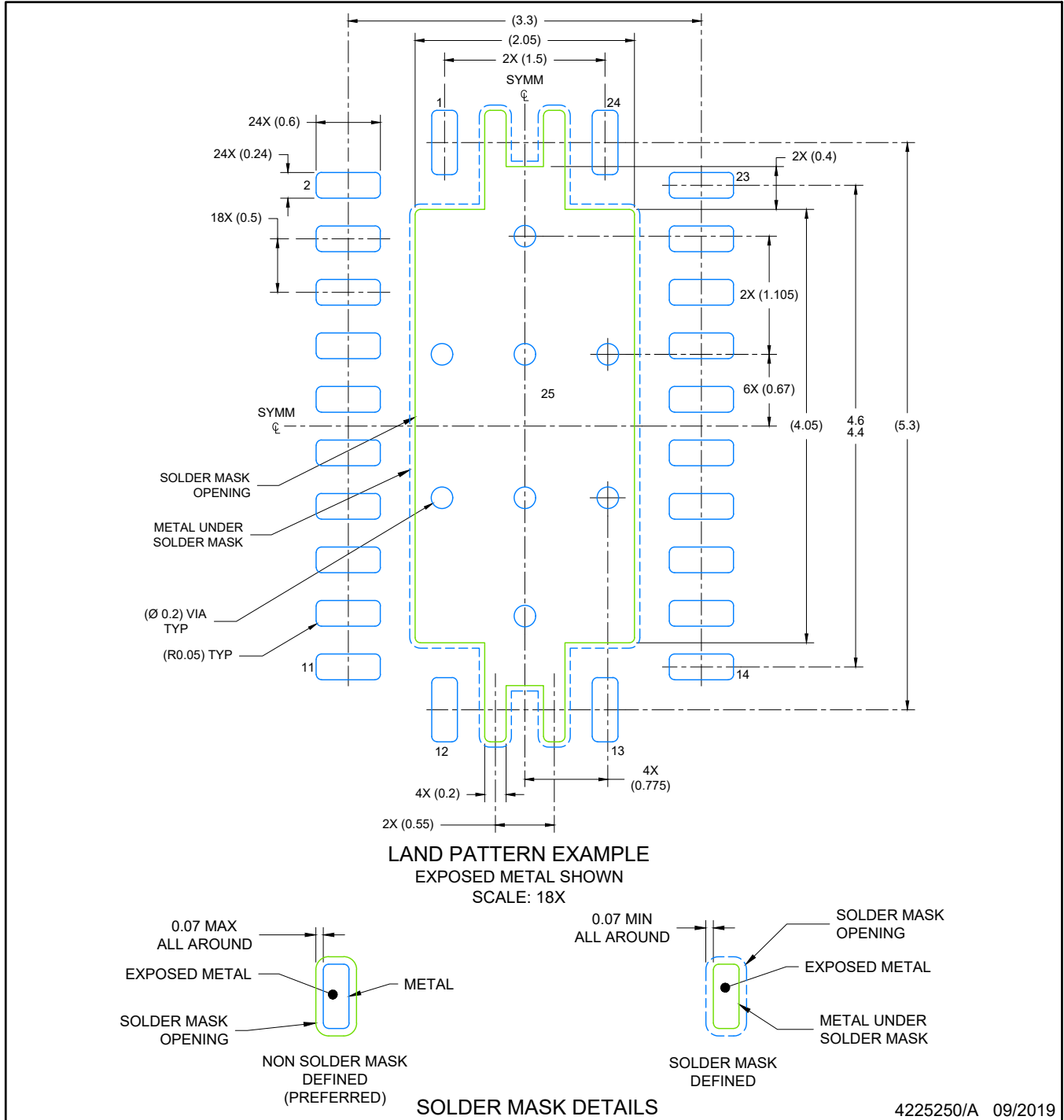

NOTES: (continued)

4. This package is designed to be soldered to a thermal pad on the board. For more information, see Texas Instruments literature number SLUA271 ([www.ti.com/lit/sluea271](http://www.ti.com/lit/sluea271)).
5. Vias are optional depending on application, refer to device data sheet. If any vias are implemented, refer to their locations shown on this view. It is recommended that vias under paste be filled, plugged or tented.

# EXAMPLE STENCIL DESIGN

RHL0024A

VQFN - 1 mm max height

PLASTIC QUAD FLATPACK- NO LEAD

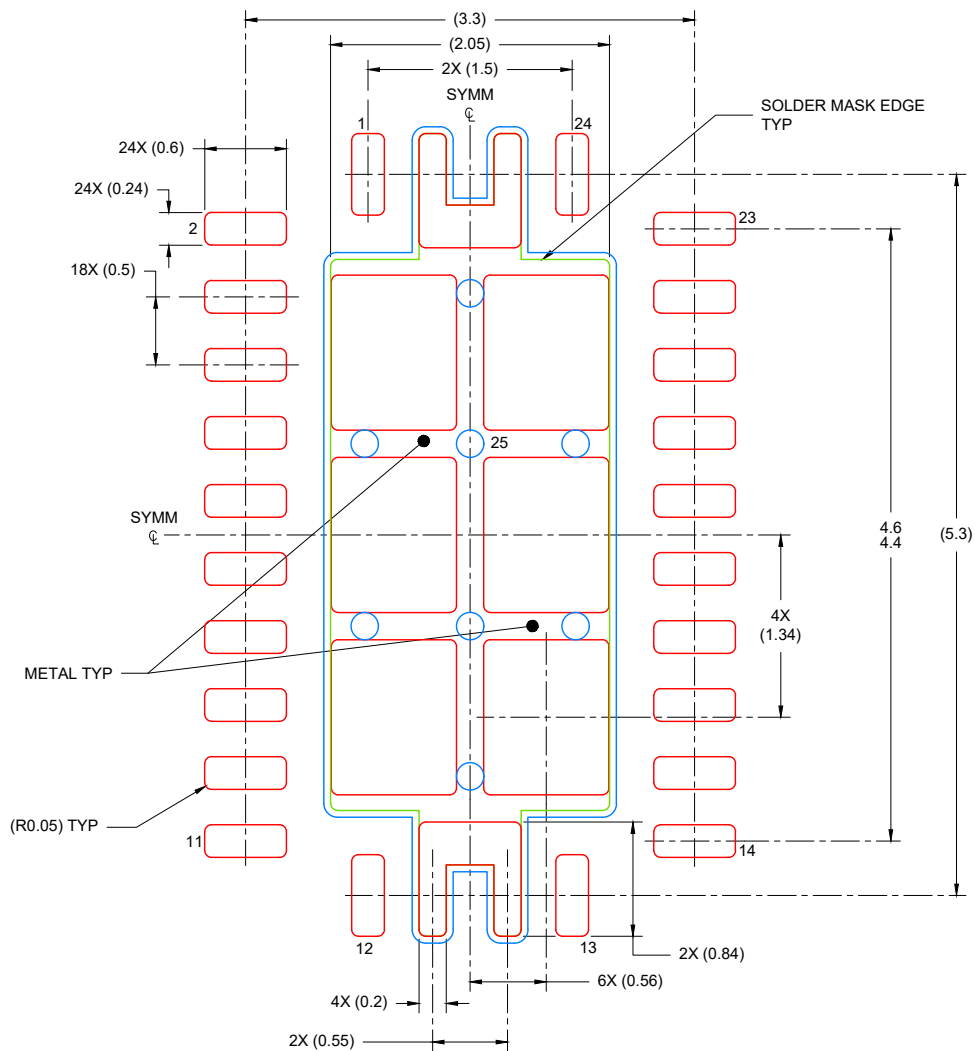

SOLDER PASTE EXAMPLE  
BASED ON 0.125 mm THICK STENCIL

EXPOSED PAD  
80% PRINTED COVERAGE BY AREA  
SCALE: 18X

4225250/A 09/2019

NOTES: (continued)

6. Laser cutting apertures with trapezoidal walls and rounded corners may offer better paste release. IPC-7525 may have alternate design recommendations.

## GENERIC PACKAGE VIEW

**RJW 24**

**UQFN - 0.55 mm max height**

2 x 4, 0.4 mm pitch

PLASTIC QUAD FLATPACK - NO LEAD

This image is a representation of the package family, actual package may vary.  
Refer to the product data sheet for package details.

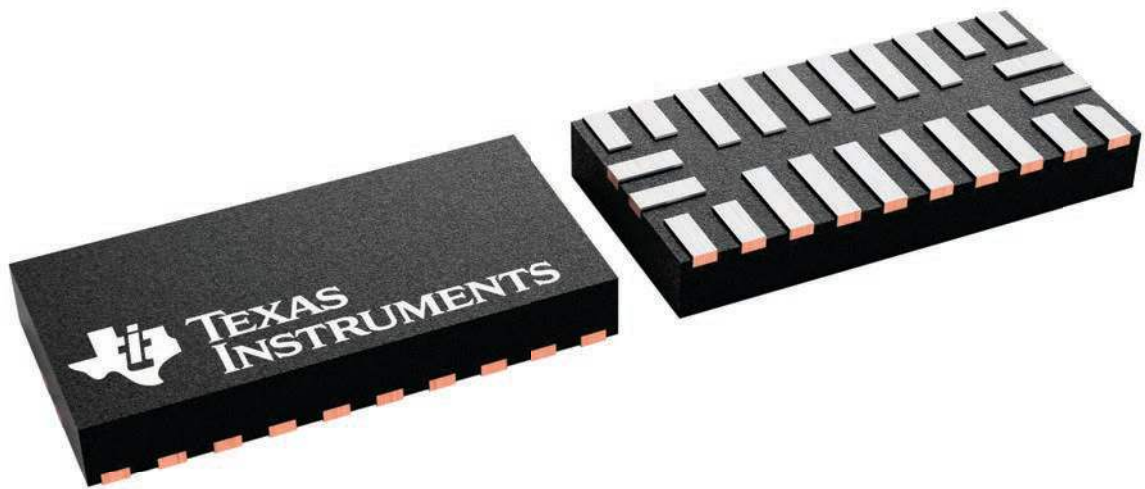

4228367/A

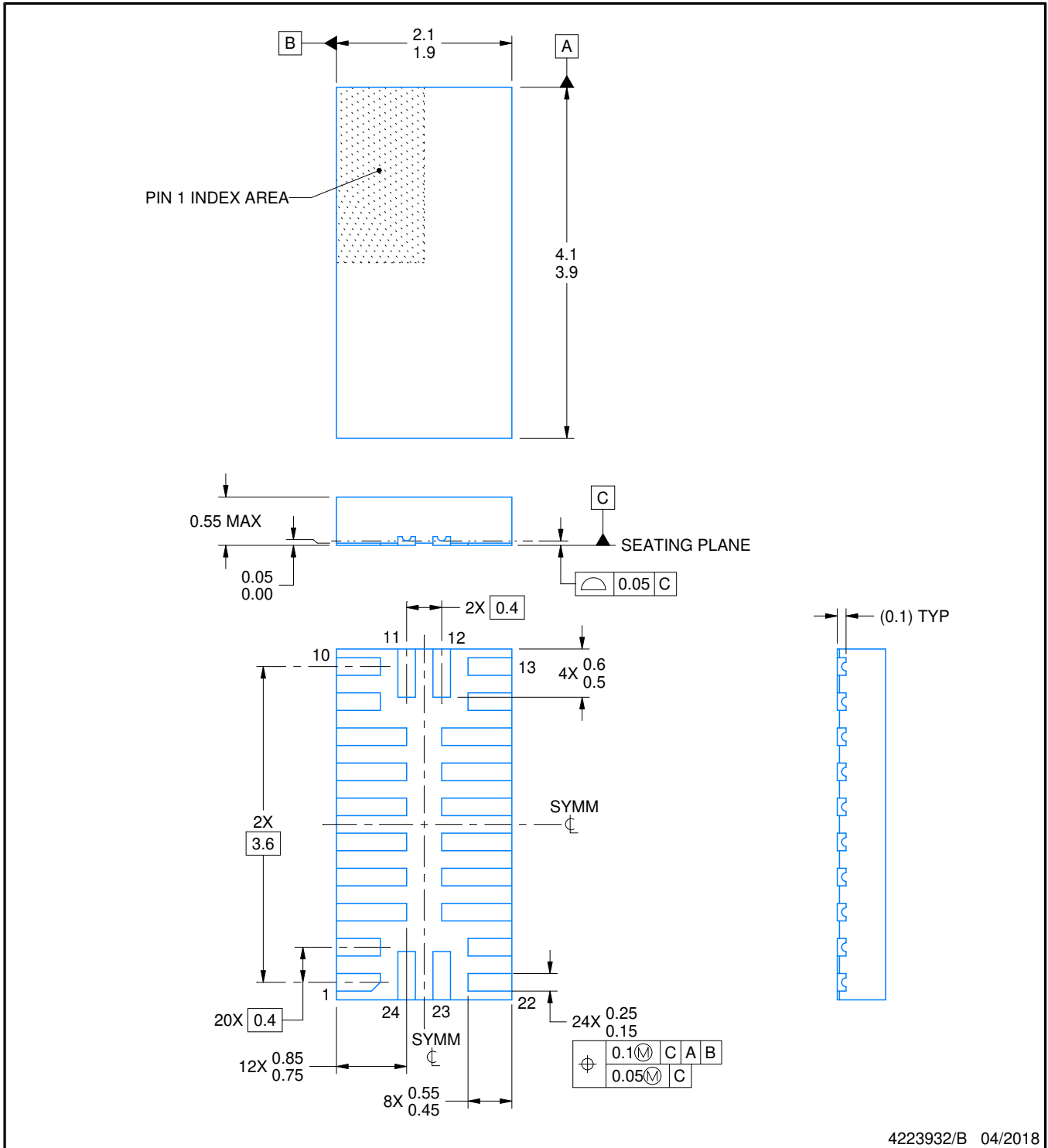

4223932/B 04/2018

NOTES:

1. All linear dimensions are in millimeters. Any dimensions in parenthesis are for reference only. Dimensioning and tolerancing per ASME Y14.5M.
2. This drawing is subject to change without notice.

# EXAMPLE BOARD LAYOUT

RJW0024A

UQFN - 0.55 mm max height

PLASTIC QUAD FLATPACK - NO LEAD

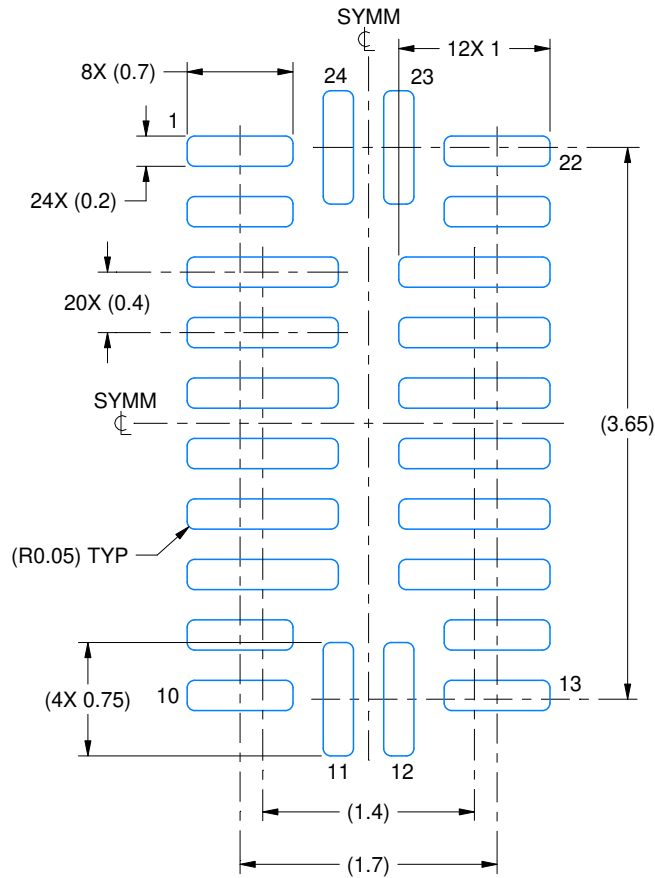

LAND PATTERN EXAMPLE  
EXPOSED METAL SHOWN  
SCALE:20X

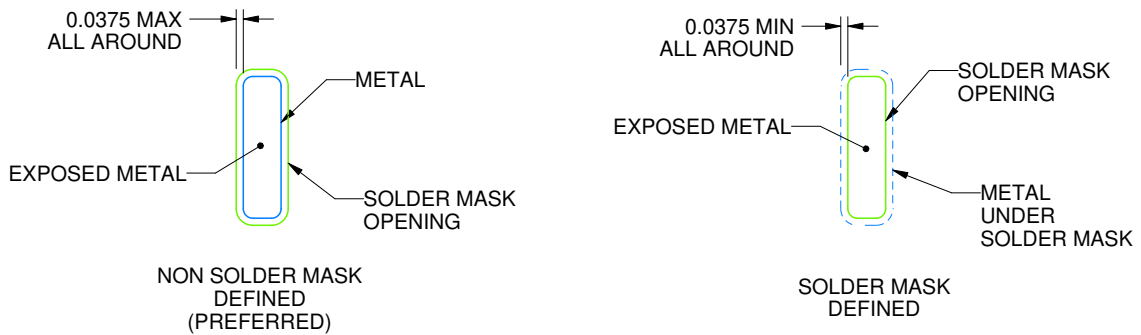

SOLDER MASK DETAILS  
NOT TO SCALE

4223932/B 04/2018

NOTES: (continued)

3. For more information, see Texas Instruments literature number SLUA271 ([www.ti.com/lit/slua271](http://www.ti.com/lit/slua271)).

# EXAMPLE STENCIL DESIGN

RJW0024A

UQFN - 0.55 mm max height

PLASTIC QUAD FLATPACK - NO LEAD

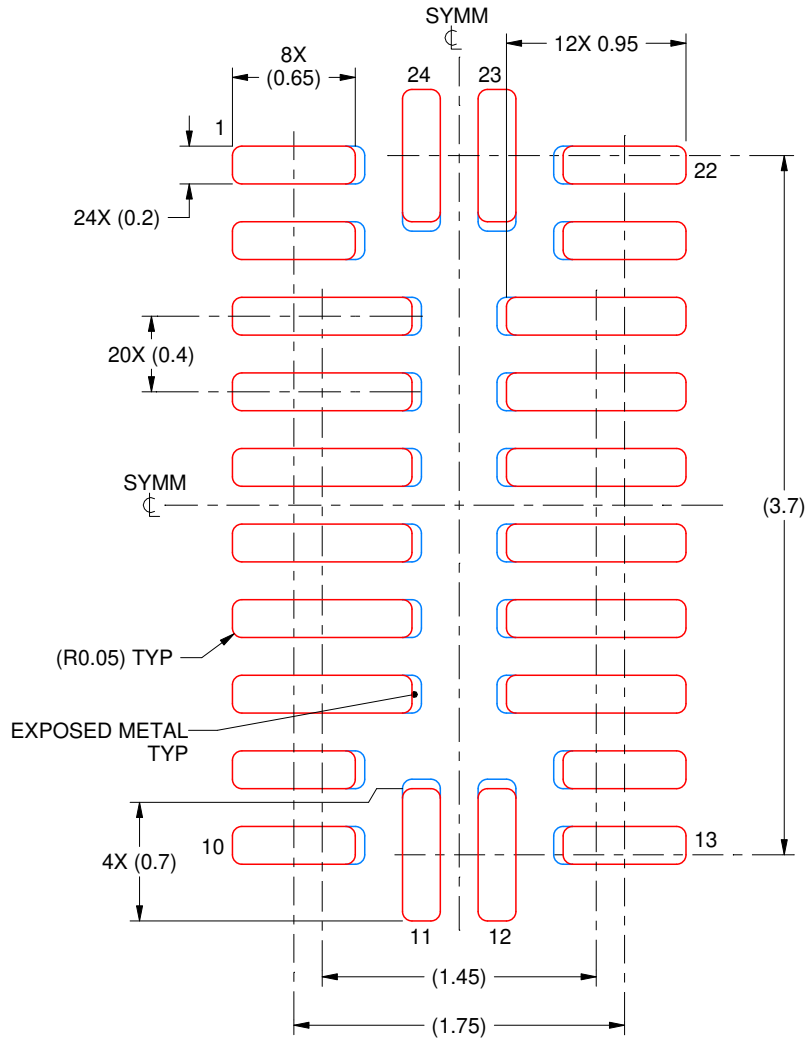

SOLDER PASTE EXAMPLE  
BASED ON 0.1 mm THICKNESS  
SCALE: 25X

4223932/B 04/2018

NOTES: (continued)

4. Laser cutting apertures with trapezoidal walls and rounded corners may offer better paste release. IPC-7525 may have alternate design recommendations.

## IMPORTANT NOTICE AND DISCLAIMER

TI PROVIDES TECHNICAL AND RELIABILITY DATA (INCLUDING DATA SHEETS), DESIGN RESOURCES (INCLUDING REFERENCE DESIGNS), APPLICATION OR OTHER DESIGN ADVICE, WEB TOOLS, SAFETY INFORMATION, AND OTHER RESOURCES "AS IS" AND WITH ALL FAULTS, AND DISCLAIMS ALL WARRANTIES, EXPRESS AND IMPLIED, INCLUDING WITHOUT LIMITATION ANY IMPLIED WARRANTIES OF MERCHANTABILITY, FITNESS FOR A PARTICULAR PURPOSE OR NON-INFRINGEMENT OF THIRD PARTY INTELLECTUAL PROPERTY RIGHTS.

These resources are intended for skilled developers designing with TI products. You are solely responsible for (1) selecting the appropriate TI products for your application, (2) designing, validating and testing your application, and (3) ensuring your application meets applicable standards, and any other safety, security, regulatory or other requirements.

These resources are subject to change without notice. TI grants you permission to use these resources only for development of an application that uses the TI products described in the resource. Other reproduction and display of these resources is prohibited. No license is granted to any other TI intellectual property right or to any third party intellectual property right. TI disclaims responsibility for, and you will fully indemnify TI and its representatives against, any claims, damages, costs, losses, and liabilities arising out of your use of these resources.

TI's products are provided subject to [TI's Terms of Sale](#) or other applicable terms available either on [ti.com](http://ti.com) or provided in conjunction with such TI products. TI's provision of these resources does not expand or otherwise alter TI's applicable warranties or warranty disclaimers for TI products.

TI objects to and rejects any additional or different terms you may have proposed.

Mailing Address: Texas Instruments, Post Office Box 655303, Dallas, Texas 75265  
Copyright © 2022, Texas Instruments Incorporated