

DO NOT SCALE FROM THIS PRINT

TABLE 1	
PART NUMBER	"B"
SCRUS-10-X-XX.XX-MBS-MB	16.0 [.63]
SCRUS-10-X-XX.XX-MBS-AM	25.0 [.98]
SCRUS-10-X-XX.XX-MBS-BC	20.0 [.79]
SCRUS-10-X-XX.XX-MBS-BM	25.0 [.98]

PLATING
 -G: .00030" GOLD ON CONTACT AREAS, NICKEL ON SHELLS

LENGTH
 -XX.XX
 (0.25M[9.842] MIN - 50.00M[1968.504] MAX)

END 2 OPTIONS
 -MB: MINI USB B TYPE PLUG NOT SEALED (THIS END NOT SEALED ONLY)
 -BC: BLUNT CUT END (SEE SHEET 5)
 -AM: USB A TYPE PLUG NOT SEALED (THIS END NOT SEALED ONLY)
 -BM: USB B TYPE PLUG NOT SEALED (THIS END NOT SEALED ONLY)

END 1 OPTIONS
 -MBS: MINI USB B TYPE RECEPTACLE SEALED (THIS END SEALED ONLY)

DESIGNED & DIMENSIONED IN MILLIMETERS[INCHES]

FIG 1
 SCRUS-10-X-XX.XX-MBS-MB SHOWN

NOTE: -00.25 AND -00.50 ARE CATALOG STANDARD LENGTHS. FOR OTHER LENGTHS CONTACT SAMTEC.

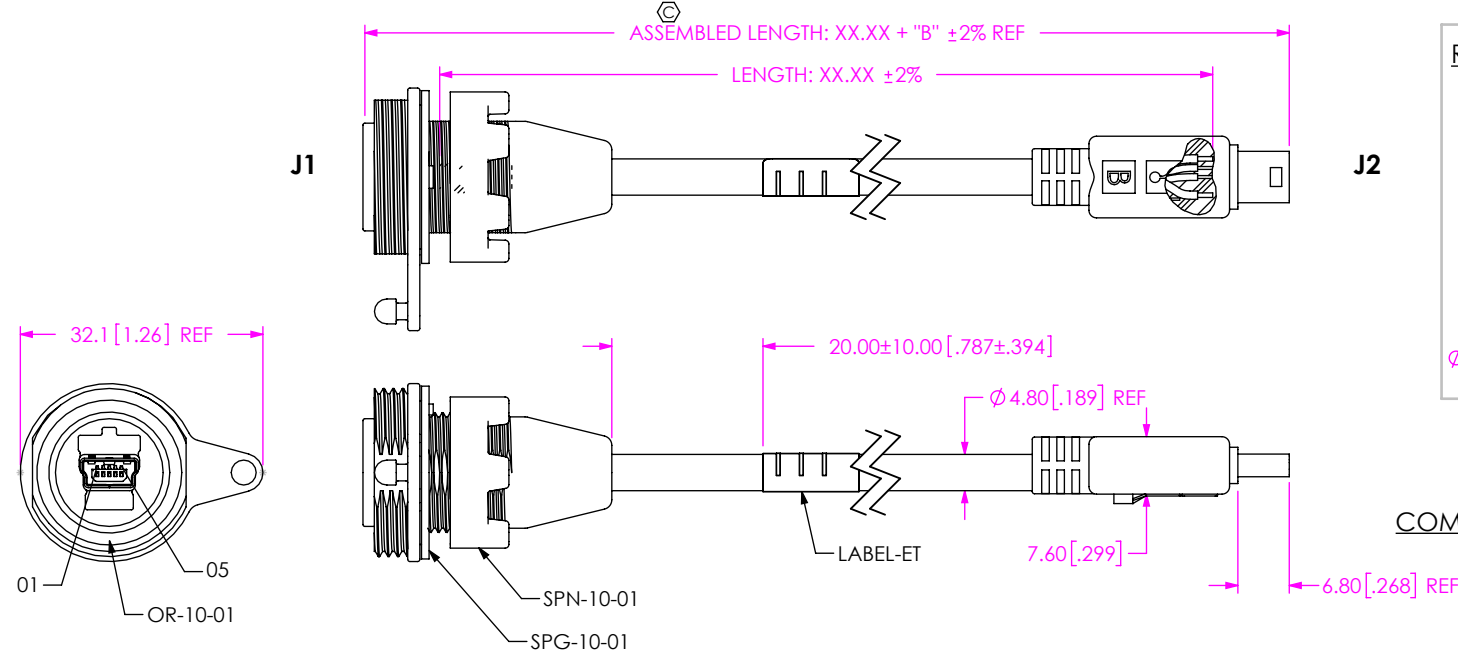

RECOMMENDED PANEL HOLE
 (SEE NOTE 5)

COMPONENTS ON OPPOSITE END HIDDEN FOR CLARITY

- NOTES:
- ⊗ REPRESENTS A CRITICAL DIMENSION.
 - ⊙ ASSEMBLY TO BE 100% TESTED FOR OPENS AND SHORTS, HIGH POT TESTED AT 200V BEFORE PREMOLD IN-PROCESS AND ON FINISHED ASSEMBLY. LABEL EACH ASSEMBLY WITH 1 LABEL-ET.
 - NOTE DELETED
 - USB LOGO TO BE RAISED 0.25 [.010].
 - PANEL THICKNESS: 0.76 [.030] - 5.21 [.205].
 - ASSEMBLY TO BE BULK PACKAGED.
 - TORQUE SPECIFICATION FOR SPN-10-01 IS 12 IN-LB.
 - NOTE DELETED.
 - ALL IDENTIFICATION MARKS MUST NOT STAND GREATER THAN 0.051 [.002] OFF THE SURFACE OF THE PART.
 - NOTE DELETED.
 - ALL EJECTOR PIN AND GATE LOCATIONS MUST BE APPROVED BY SAMTEC PRODUCT ENGINEERING.
 - ANY ADDITIONAL VOIDING AND/OR MODIFICATIONS TO VOIDING MUST BE APPROVED BY SAMTEC PRODUCT ENGINEERING.
 - NOTE DELETED.
 - NOTE DELETED.
 - PART MUST SCREW INTO SAMTEC PART # SCN-10-01
 - PART MUST SCREW INTO SAMTEC PART # SPN-10-01
 - THIS IS A COMPONENT OF USBP-A-01-G-B-01 (CALLED OUT ON THE BOM), BUT LABELED INDIVIDUALLY FOR ASSEMBLY PURPOSES.
 - LENGTHS GREATER THAN 0.50 M ARE NOT SUPPORTED BY USB 2.0 TEST DATA.
 - THIS IS A COMPONENT OF USBP-B-01-G-B-01 (CALLED OUT ON THE BOM), BUT LABELED INDIVIDUALLY FOR ASSEMBLY PURPOSES.
 - REFER TO MD-XXX-XX-XXXX-XX FOR SAMTEC MATERIAL PART NUMBER.

THIS PRODUCT MANUFACTURED WITH LEAD-FREE PROCESSING

<p>UNLESS OTHERWISE SPECIFIED, DIMENSIONS ARE IN MILLIMETERS.</p> <p>TOLERANCES ARE:</p> <table border="0"> <tr> <td>DECIMALS</td> <td>ANGLES</td> </tr> <tr> <td>X.X: ±0.35 [.013]</td> <td>2°</td> </tr> <tr> <td>X.XX: ±0.25 [.010]</td> <td></td> </tr> <tr> <td>X.XXX: ±0.15 [.006]</td> <td></td> </tr> </table>	DECIMALS	ANGLES	X.X: ±0.35 [.013]	2°	X.XX: ±0.25 [.010]		X.XXX: ±0.15 [.006]		<p>PROPRIETARY NOTE</p> <p>THIS DOCUMENT CONTAINS CONFIDENTIAL AND PROPRIETARY INFORMATION AND ALL DESIGN, MANUFACTURING, REPRODUCTION, USE, PATENT RIGHTS AND SALES RIGHTS ARE EXPRESSLY RESERVED BY SAMTEC, INC. THIS DOCUMENT SHALL NOT BE DISCLOSED, IN WHOLE OR PART, TO ANY UNAUTHORIZED PERSON OR ENTITY NOR REPRODUCED, TRANSFERRED OR INCORPORATED IN ANY OTHER PROJECT IN ANY MANNER WITHOUT THE EXPRESS WRITTEN CONSENT OF SAMTEC, INC.</p>	<p>samtec</p> <p>520 PARK EAST BLVD, NEW ALBANY, IN 47150 PHONE: 812.944-6733 FAX: 812-948-5047 e-Mail: info@SAMTEC.com code: 55322</p>
	DECIMALS	ANGLES								
X.X: ±0.35 [.013]	2°									
X.XX: ±0.25 [.010]										
X.XXX: ±0.15 [.006]										
<p>MATERIAL:</p> <p>INSULATOR: GLASS FILLED THERMOPLASTIC CONTACTS: COPPER ALLOY, SHIELDS: CRS CABLE NUT: PA66 SEALED PREMOLD: RITFLEX 640-RD30565P62-BLACK, SHOT WEIGHT: 9.07g[.020lb] SEALED OVERMOLD: ZITEL PA70G13L 52-919088KS; MAX REGRIND: 10% SHOT WEIGHT: 10.43g[.023lb]</p> <p>NON-SEALED OVERMOLD: PVC ALP-411-75-BK-2885; MAX REGRIND: 30% SHOT WEIGHT: 6.80g[.015lb]</p>	<p>DESCRIPTION: PANEL MOUNT SEALED MINI USB CABLE</p> <p>DWG. NO. SCRUS-10-X-XX.XX-XXX-XX</p> <p>BY: B. PERRY 09-01-2010 SHEET 1 OF 10</p>									

FIG 2
SCRUS-10-X-XX.XX-MBS-BC SHOWN
(SAME AS FIG 1 UNLESS OTHERWISE STATED)

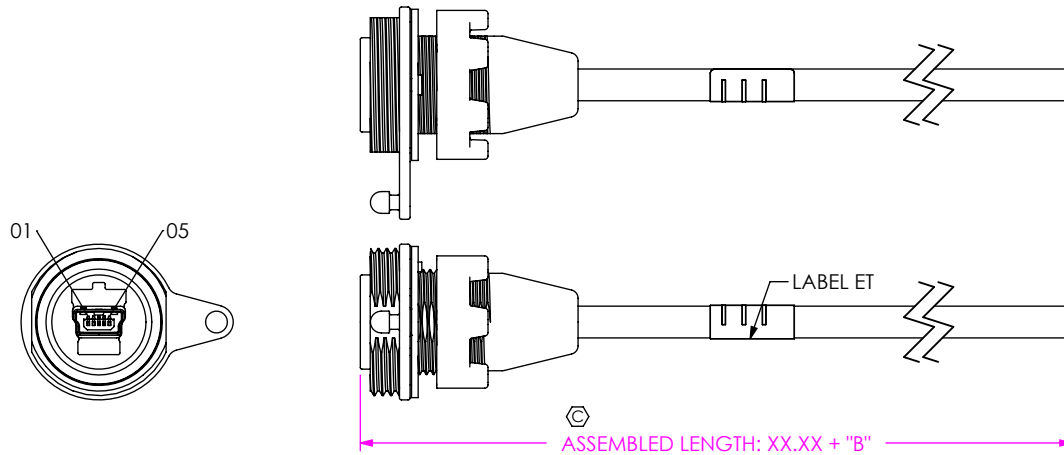

FIG 3
SCRUS-10-X-XX.XX-MBS-AM SHOWN
(SAME AS FIG 1 UNLESS OTHERWISE STATED)

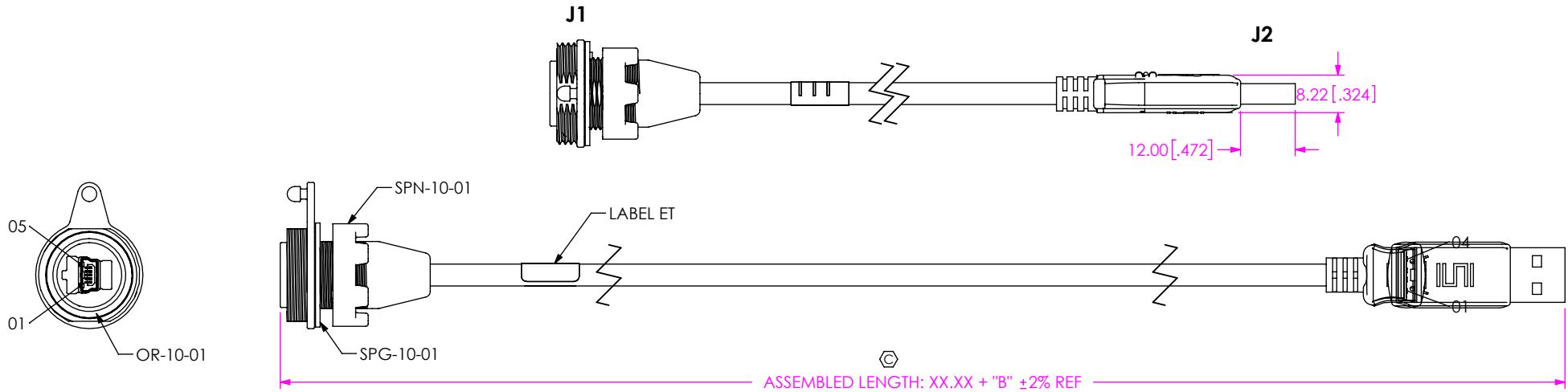

TABLE 3: PIN-OUT

J1 End	Wire Color	J2 End			
-MBS		-MB	-BC	-AM	-BM
01	RED	01	01	01	01
02	WHITE	02	02	02	02
03	GREEN	03	03	03	03
04	NOT CONNECTED	04	04	n/a	n/a
05	BLACK	05	05	04	04
USB Shield	DRAIN/CABLE SHIELD	USB Shield	USB Shield	USB Shield	USB Shield

PROPRIETARY NOTE
THIS DOCUMENT CONTAINS CONFIDENTIAL AND PROPRIETARY INFORMATION AND ALL DESIGN, MANUFACTURING, REPRODUCTION, USE, PATENT RIGHTS AND SALES RIGHTS ARE EXPRESSLY RESERVED BY SAMTEC, INC. THIS DOCUMENT SHALL NOT BE DISCLOSED, IN WHOLE OR PART, TO ANY UNAUTHORIZED PERSON OR ENTITY NOR REPRODUCED, TRANSFERRED OR INCORPORATED IN ANY OTHER PROJECT IN ANY MANNER WITHOUT THE EXPRESS WRITTEN CONSENT OF SAMTEC, INC.

DO NOT SCALE DRAWING

SHEET SCALE: 0.75:1



520 PARK EAST BLVD., NEW ALBANY, IN 47150
PHONE: 812-944-6733 FAX: 812-948-5047
e-Mail: info@SAMTEC.com code: 55322

DESCRIPTION:
PANEL MOUNT SEALED MINI USB CABLE

DWG. NO.
SCRUS-10-X-XX.XX-XXX-XX

BY: B. PERRY 09-01-2010 SHEET 2 OF 10

**-MBS -MB END OPTIONS
IN-PROCESS 1**
CUT CABLES TO LENGTH & STRIP OUTER
JACKET TO DIMENSION SHOWN

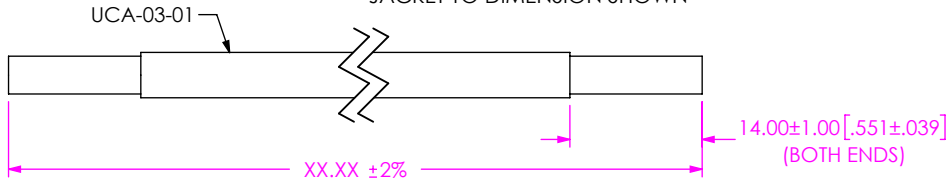

**-MBS -MB END OPTIONS
IN-PROCESS 2**
TWIST SHIELD & TRIM INDIVIDUAL WIRES TO DIM SHOWN

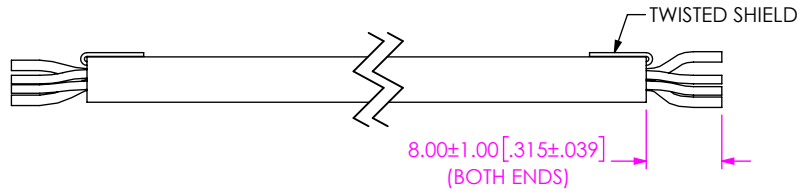

**-MBS -MB END OPTIONS
IN-PROCESS 3**
STRIP INDIVIDUAL WIRES TO DIMENSION SHOWN

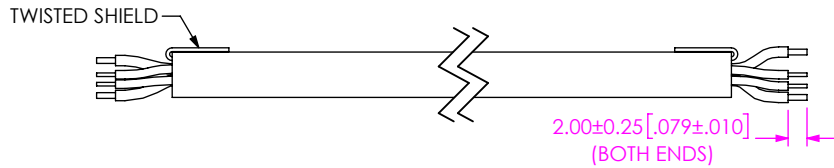

**-MBS -MB END OPTIONS
IN-PROCESS 4**
TERMINATE TO MUSB-05-G-B-C & SUB-MUSBP-05-B-G-C

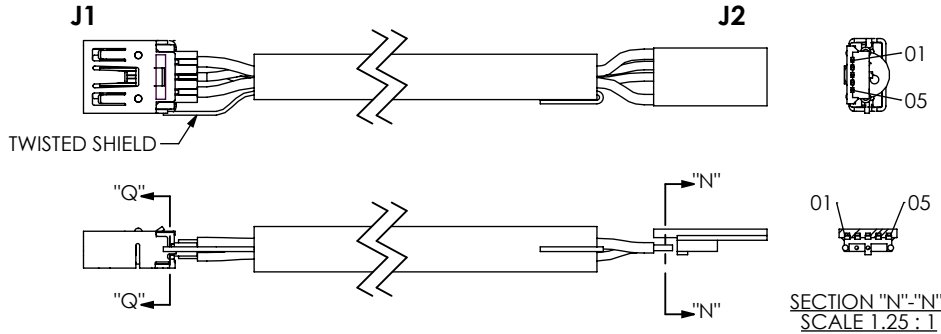

**SECTION "Q"-"Q"
SCALE 2:1**

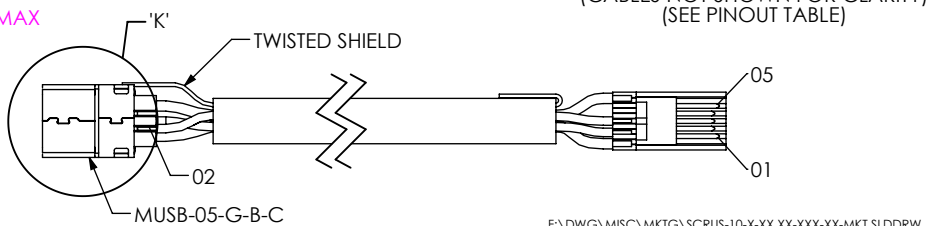
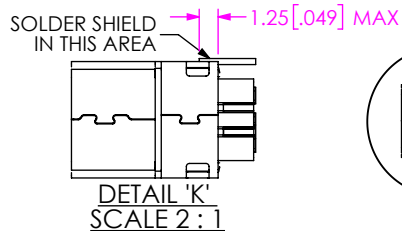

F:\DWG\MISC\MKTG\SCRUS-10-X-XX.XX-XXX-XX-MKT.SLDDRW

**-MBS -MB END OPTIONS
IN-PROCESS 5**
ADD MUSBS-05-B-N-01

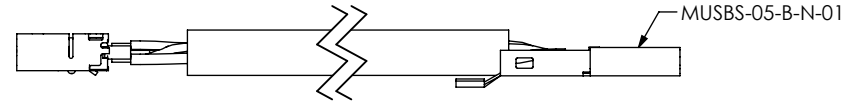

**-MBS -MB END OPTIONS
IN-PROCESS 6**
ADD MUSBS-05-B-N-02

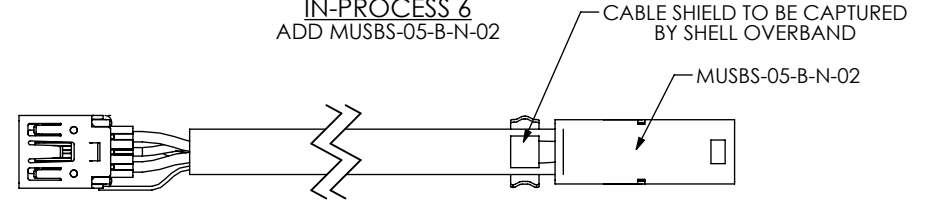

**-MBS -MB END OPTIONS
IN-PROCESS 7**
CRIMP SHELLS OVERBAND & ADD TRIM EXCESS SHIELD



**-MBS -MB END OPTIONS
IN-PROCESS 8**
ADD PREMOLD

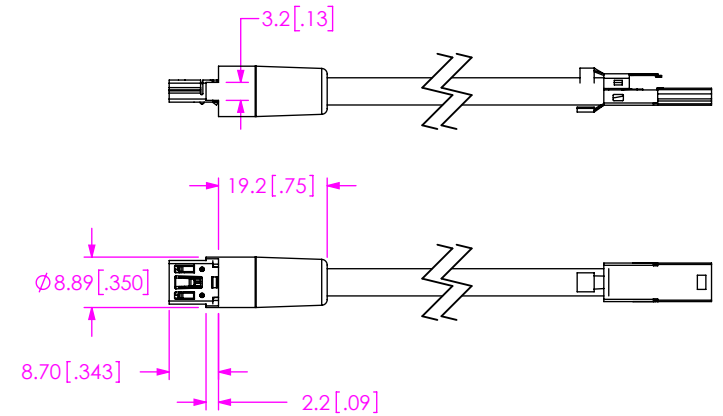

PROPRIETARY NOTE
THIS DOCUMENT CONTAINS CONFIDENTIAL AND PROPRIETARY INFORMATION AND ALL DESIGN, MANUFACTURING, REPRODUCTION, USE, PATENT RIGHTS AND SALES RIGHTS ARE EXPRESSLY RESERVED BY SAMTEC, INC. THIS DOCUMENT SHALL NOT BE DISCLOSED, IN WHOLE OR IN PART, TO ANY UNAUTHORIZED PERSON OR ENTITY NOR REPRODUCED, TRANSFERRED OR INCORPORATED IN ANY OTHER PROJECT IN ANY MANNER WITHOUT THE EXPRESS WRITTEN CONSENT OF SAMTEC, INC.

DO NOT SCALE DRAWING
SHEET SCALE: 0.75:1



520 PARK EAST BLVD, NEW ALBANY, IN 47150
PHONE: 812-944-6733 FAX: 812-948-5047
e-Mail: info@SAMTEC.com code: 55322

DESCRIPTION:
PANEL MOUNT SEALED MINI USB CABLE
DWG. NO.
SCRUS-10-X-XX.XX-XXX-XX
BY: B. PERRY 09-01-2010 SHEET 3 OF 10

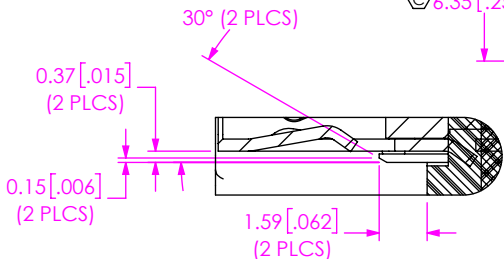
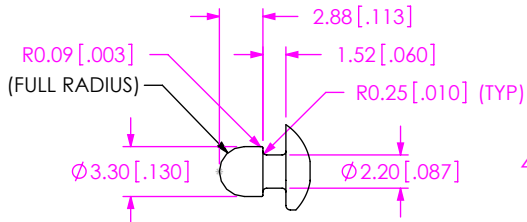
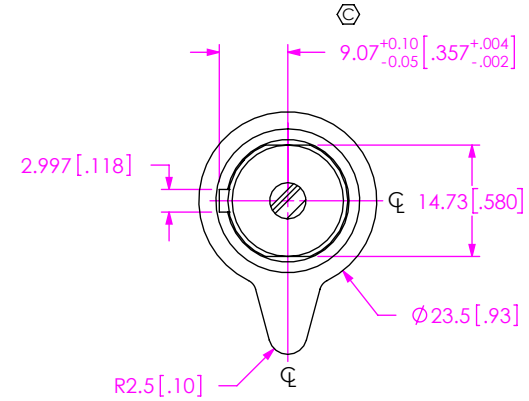
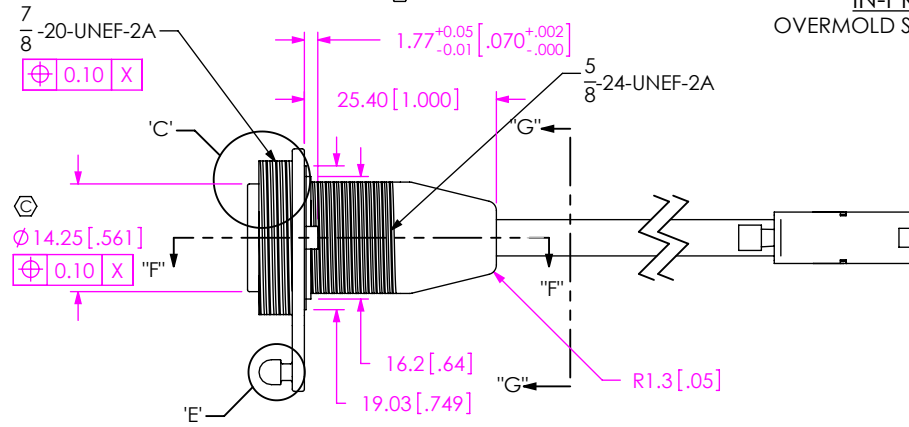
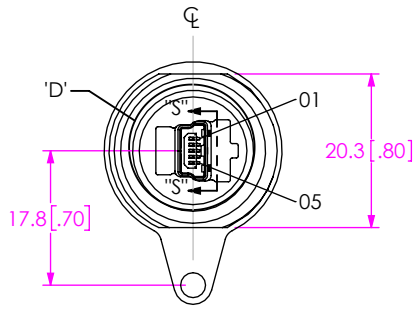

DETAIL 'R'
SCALE 4:1

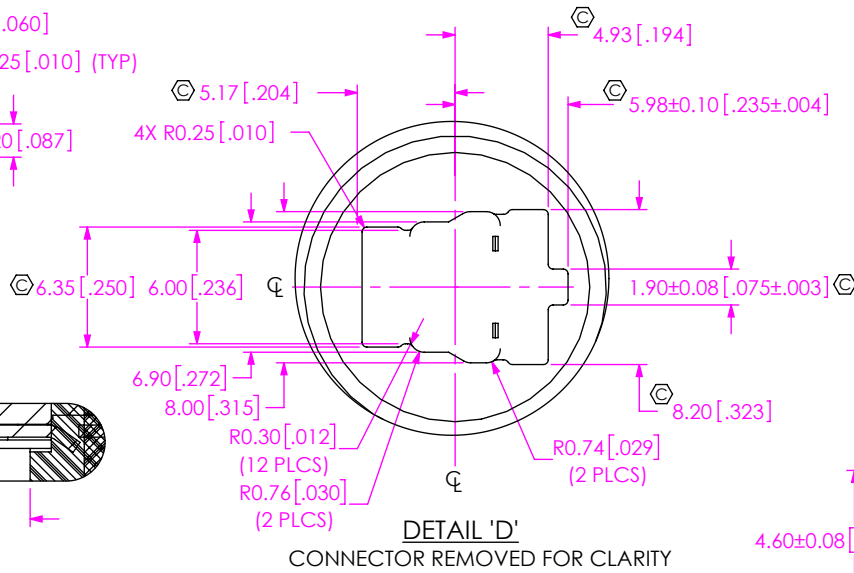

DETAIL 'D'
CONNECTOR REMOVED FOR CLARITY

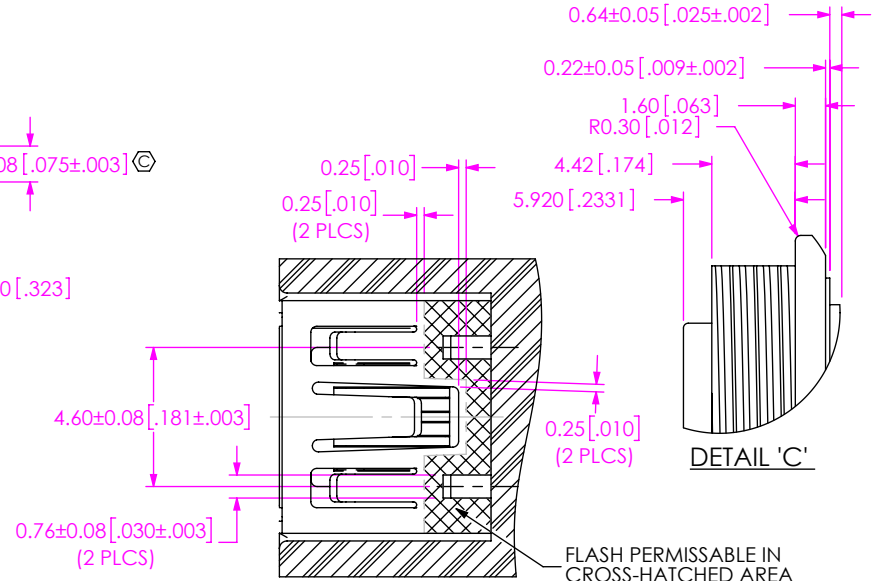

SECTION "S"-"S"
SCALE 4:1

FLASH PERMISSABLE IN
CROSS-HATCHED AREA

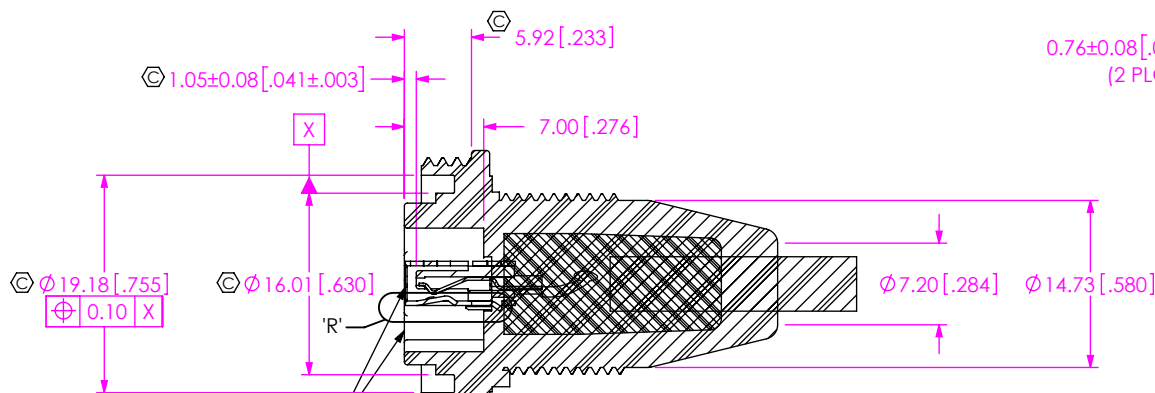

SECTION "F"-"F"
SCALE 1.5:1

CONNECTOR HOUSING MAY EXTEND
OUTSIDE OF OVER-MOLD OR BE RECESSED
INTO OVER-MOLD BY 0.25 [.010] MAX.

PROPRIETARY NOTE
THIS DOCUMENT CONTAINS CONFIDENTIAL AND
PROPRIETARY INFORMATION AND ALL DESIGN,
MANUFACTURING, REPRODUCTION, USE, PATENT RIGHTS
AND SALES RIGHTS ARE EXPRESSLY RESERVED BY SAMTEC,
INC. THIS DOCUMENT SHALL NOT BE DISCLOSED, IN WHOLE
OR PART, TO ANY UNAUTHORIZED PERSON OR ENTITY NOR
REPRODUCED, TRANSFERRED OR INCORPORATED IN ANY
OTHER PROJECT IN ANY MANNER WITHOUT THE EXPRESS
WRITTEN CONSENT OF SAMTEC, INC.

DO NOT SCALE DRAWING

SHEET SCALE: 0.75:1



520 PARK EAST BLVD, NEW ALBANY, IN 47150
PHONE: 812-944-6733 FAX: 812-948-5047
e-Mail: info@SAMTEC.com code: 55322

DESCRIPTION:
PANEL MOUNT SEALED MINI USB CABLE

DWG. NO.
SCRUS-10-X-XX.XX-XXX-XX

BY: B. PERRY 09-01-2010 SHEET 4 OF 10

-MBS -MB END OPTIONS
IN-PROCESS 10
OVERMOLD UNSEALED END

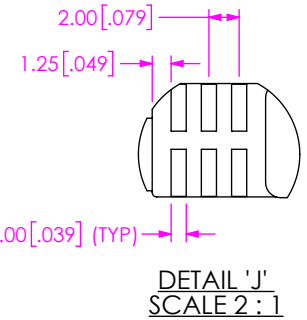
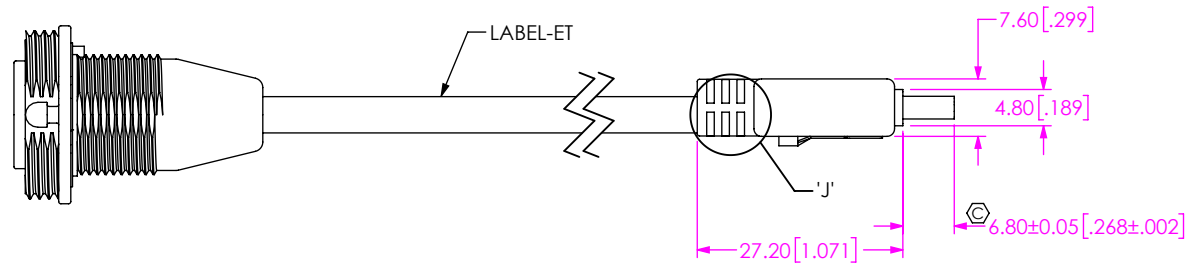
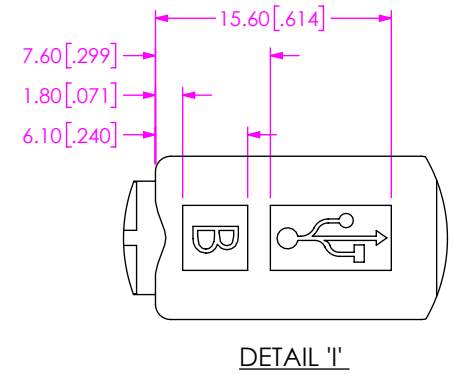
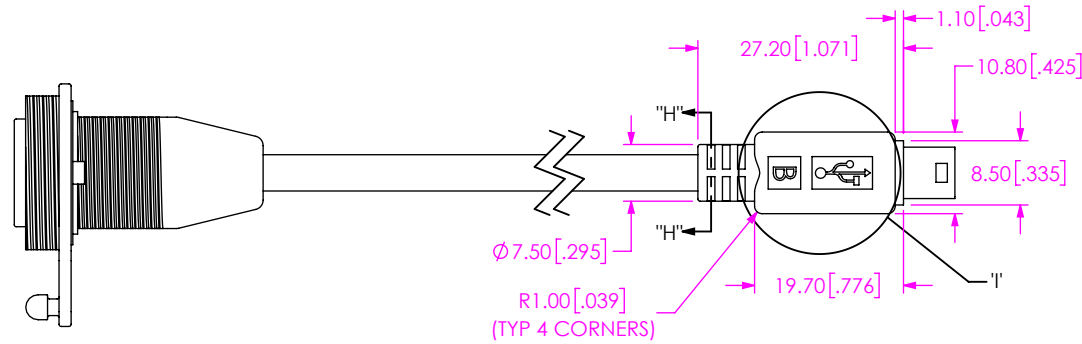
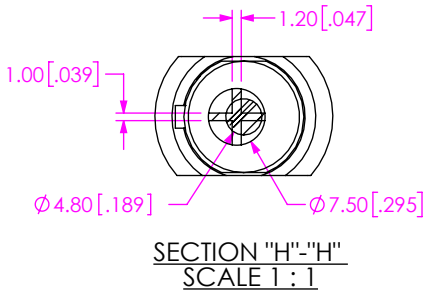

-MBS -MB END OPTIONS
IN-PROCESS 11
ADD SPG-10-01 & SPN-10-01 & OR-10-01

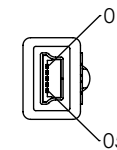
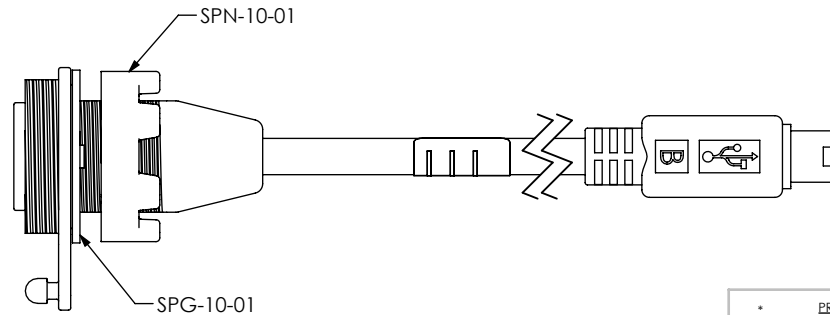
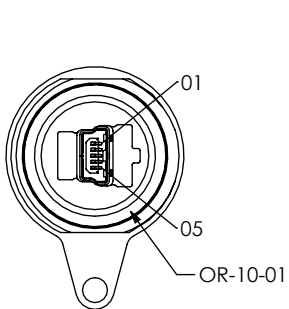

PROPRIETARY NOTE
THIS DOCUMENT CONTAINS CONFIDENTIAL AND PROPRIETARY INFORMATION AND ALL DESIGN, MANUFACTURING, REPRODUCTION, USE, PATENT RIGHTS AND SALES RIGHTS ARE EXPRESSLY RESERVED BY SAMTEC, INC. THIS DOCUMENT SHALL NOT BE DISCLOSED, IN WHOLE OR PART, TO ANY UNAUTHORIZED PERSON OR ENTITY NOR REPRODUCED, TRANSFERRED OR INCORPORATED IN ANY OTHER PROJECT IN ANY MANNER WITHOUT THE EXPRESS WRITTEN CONSENT OF SAMTEC, INC.

DO NOT SCALE DRAWING

SHEET SCALE: 0.75:1



520 PARK EAST BLVD, NEW ALBANY, IN 47150
PHONE: 812-944-6733 FAX: 812-948-5047
e-Mail: info@SAMTEC.com code: 55322

DESCRIPTION:
PANEL MOUNT SEALED MINI USB CABLE

DWG. NO.
SCRUS-10-X-XX.XX-XXX-XX

BY: B. PERRY 09-01-2010 SHEET 5 OF 10

**-MBS -BC END OPTIONS
IN-PROCESS 1**
CUT CABLES TO LENGTH & STRIP OUTER
JACKET TO DIMENSION SHOWN

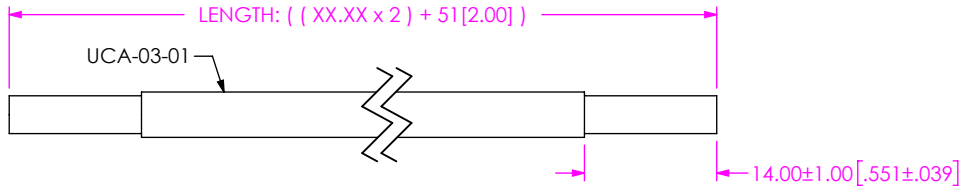

**-MBS -BC END OPTIONS
IN-PROCESS 2**
TRIM WIRES TO LENGTH & TWIST SHIELD

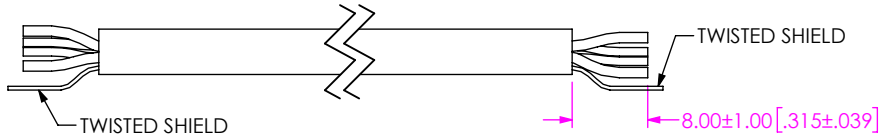

**-MBS -BC END OPTIONS
IN-PROCESS 3**
STRIP INDIVIDUAL WIRES TO DIMENSION SHOWN

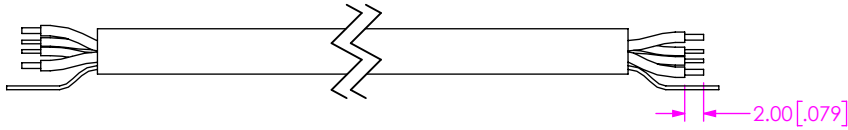

**-MBS -BC END OPTIONS
IN-PROCESS 4**
TERMINATE TO MUSB-05-G-B-C

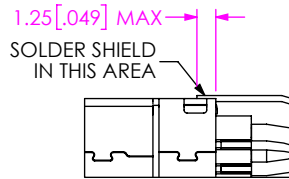
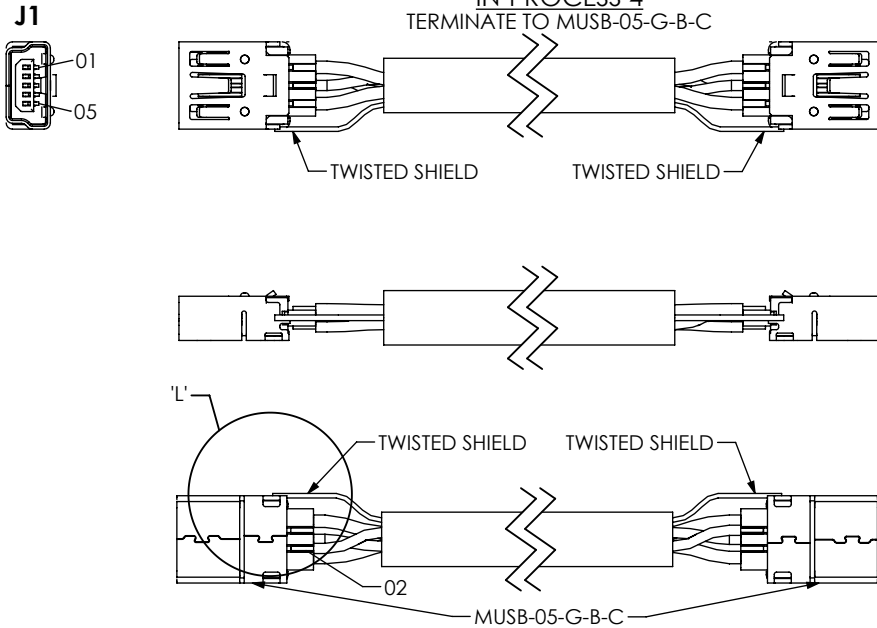

DETAIL 'L'
SCALE 2 : 1

**-MBS -BC END OPTIONS
IN-PROCESS 5**
ADD PREMOLD, SAME AS -MBS -MB IN-PROCESS 8

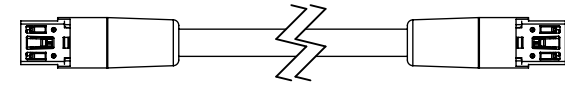

**-MBS -BC END OPTIONS
IN-PROCESS 6**
ADD OVERMOLD, SAME AS -MBS -MB IN-PROCESS 9

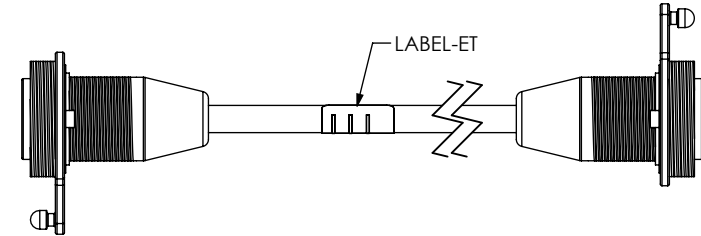

**-MBS -BC END OPTIONS
IN-PROCESS 7**
CUT IN HALF AND TRIM TO LENGTH
ADD SPN-10-01, SPG-10-01, & OR-10-01

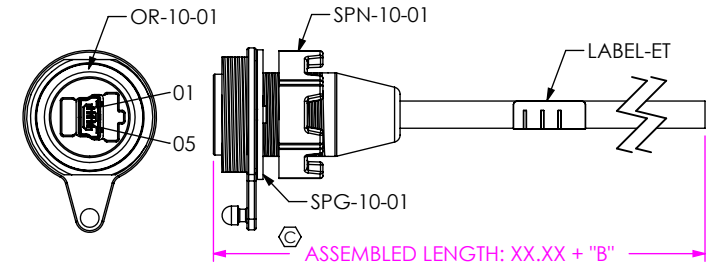

PROPRIETARY NOTE

THIS DOCUMENT CONTAINS CONFIDENTIAL AND PROPRIETARY INFORMATION AND ALL DESIGN, MANUFACTURING, REPRODUCTION, USE, PATENT RIGHTS AND SALES RIGHTS ARE EXPRESSLY RESERVED BY SAMTEC, INC. THIS DOCUMENT SHALL NOT BE DISCLOSED, IN WHOLE OR PART, TO ANY UNAUTHORIZED PERSON OR ENTITY NOR REPRODUCED, TRANSFERRED OR INCORPORATED IN ANY OTHER PROJECT IN ANY MANNER WITHOUT THE EXPRESS WRITTEN CONSENT OF SAMTEC, INC.

SHEET SCALE: 0.75:1

DO NOT SCALE DRAWING



520 PARK EAST BLVD, NEW ALBANY, IN 47150
PHONE: 812-944-6733 FAX: 812-948-5047
e-Mail: info@SAMTEC.com code: 55322

DESCRIPTION:
PANEL MOUNT SEALED MINI USB CABLE

DWG. NO.
SCRUS-10-X-XX.XX-XXX-XX

BY: B. PERRY 09-01-2010 SHEET 6 OF 10

-MBS -AM END OPTION
IN-PROCESS 1
STRIP OUTER JACKET TO DIMENSION SHOWN

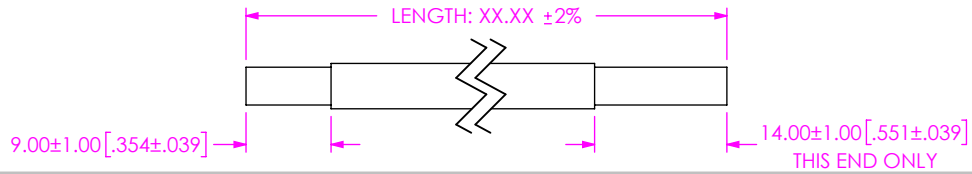

-MBS -AM END OPTION
IN-PROCESS 2
TWIST SHIELD & TRIM INDIVIDUAL WIRES

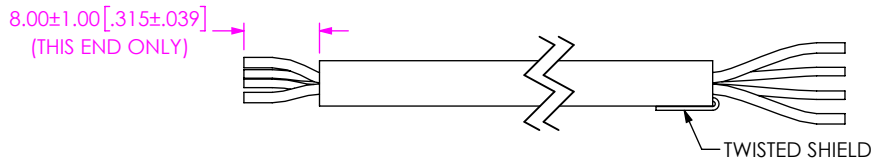

-MBS -AM END OPTION
IN-PROCESS 3
STRIP INDIVIDUAL WIRES TO DIMENSION SHOWN

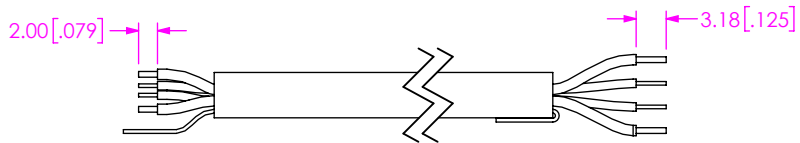

-MBS -AM END OPTION
IN-PROCESS 4
TERMINATE TO MUSB-05-G-B-C & SUB-USB-A-X-B-XX
(SEE NOTE 17)

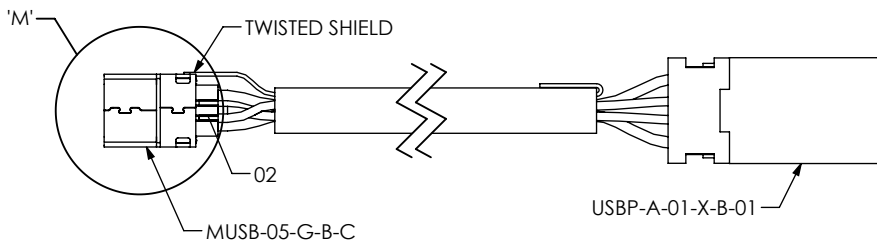
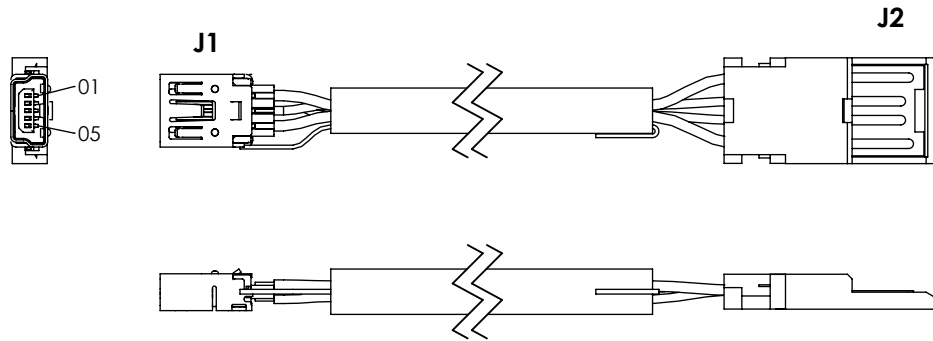

-MBS -AM END OPTION
IN-PROCESS 5
ADD USBS-A-X-01-XX (SEE NOTE 17)

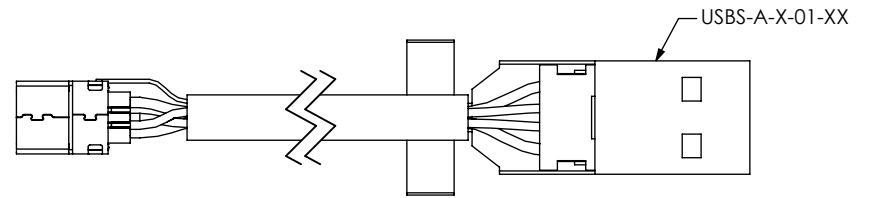

-MBS -AM END OPTION
IN-PROCESS 6
ADD USBS-A-X-02-XX (SEE NOTE 17)

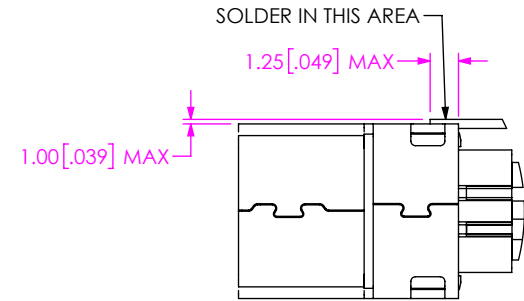
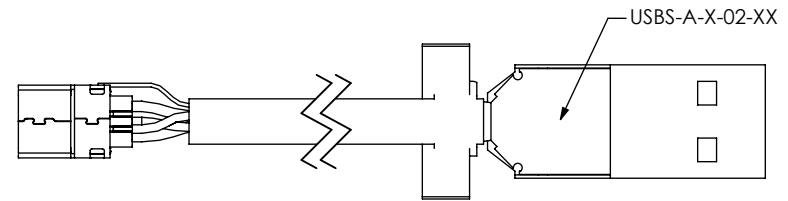

DETAIL 'M'
SCALE 3 : 1

PROPRIETARY NOTE
THIS DOCUMENT CONTAINS CONFIDENTIAL AND PROPRIETARY INFORMATION AND ALL DESIGN, MANUFACTURING, REPRODUCTION, USE, PATENT RIGHTS AND SALES RIGHTS ARE EXPRESSLY RESERVED BY SAMTEC, INC. THIS DOCUMENT SHALL NOT BE DISCLOSED, IN WHOLE OR PART, TO ANY UNAUTHORIZED PERSON OR ENTITY NOR REPRODUCED, TRANSFERRED OR INCORPORATED IN ANY OTHER PROJECT IN ANY MANNER WITHOUT THE EXPRESS WRITTEN CONSENT OF SAMTEC, INC.

DO NOT SCALE DRAWING

SHEET SCALE: 1:5

samtec

520 PARK EAST BLVD, NEW ALBANY, IN 47150
PHONE: 812-944-6733 FAX: 812-948-5047
e-Mail: info@SAMTEC.com code: 55322

DESCRIPTION:
PANEL MOUNT SEALED MINI USB CABLE

DWG. NO.
SCRUS-10-X-XX.XX-XXX-XX

BY: B. PERRY 09-01-2010 SHEET 7 OF 10

**-MBS -AM END OPTION
IN-PROCESS 7
CRIMP SHELL OVERBAND**

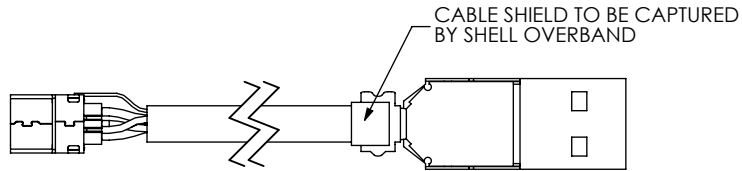

**-MBS -AM END OPTION
IN-PROCESS 8
ADD MINI USB B PREMOLD, SAME AS -MB IN-PROCESS 8**

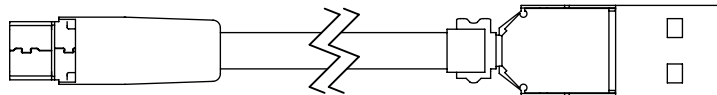

**-MBS -AM END OPTION
IN-PROCESS 9
ADD MINI USB B OVERMOLD, SAME AS -MB IN-PROCESS 9**

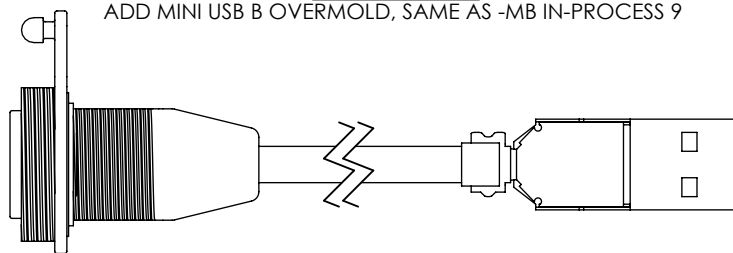

**-MBS -AM END OPTION
IN-PROCESS 10
ADD USB A OVERMOLD**

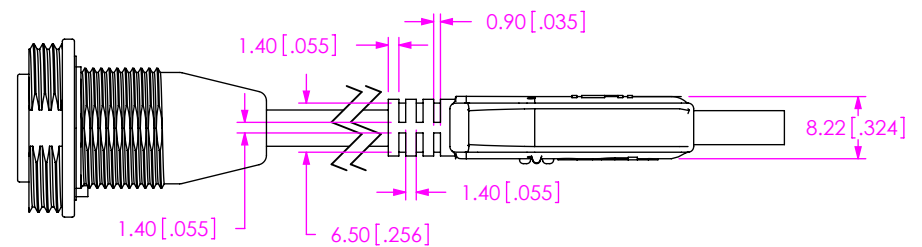
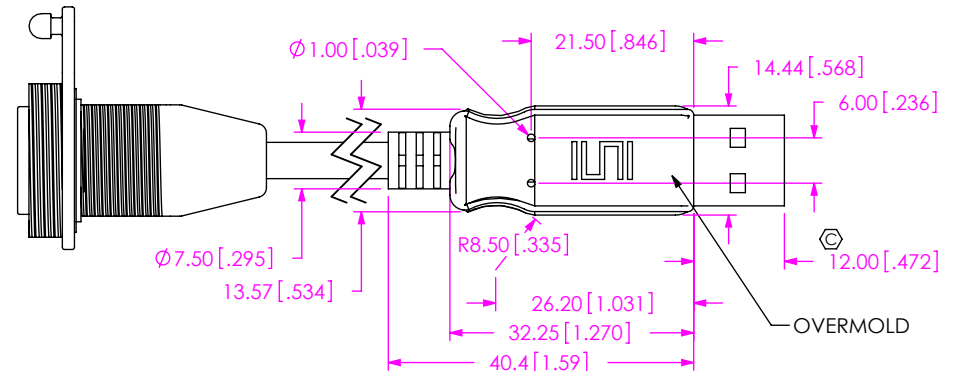

**-MBS -AM END OPTION
IN-PROCESS 11
ADD SPG-10-01 & SPN-10-01 & OR-10-01**

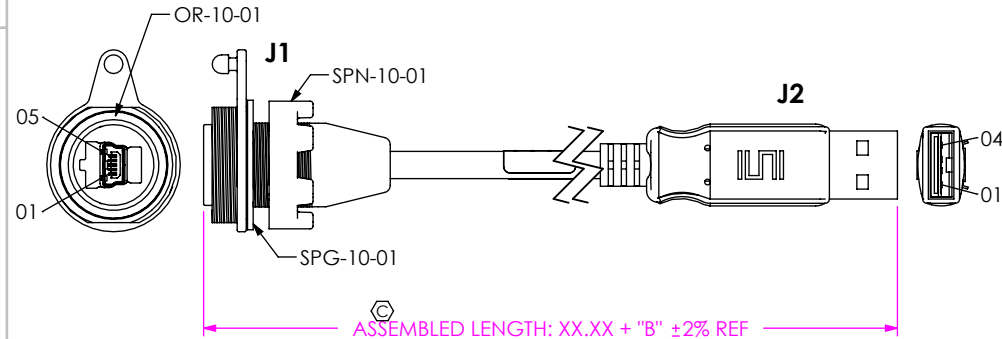

PROPRIETARY NOTE
THIS DOCUMENT CONTAINS CONFIDENTIAL AND PROPRIETARY INFORMATION AND ALL DESIGN, MANUFACTURING, REPRODUCTION, USE, PATENT RIGHTS AND SALES RIGHTS ARE EXPRESSLY RESERVED BY SAMTEC, INC. THIS DOCUMENT SHALL NOT BE DISCLOSED, IN WHOLE OR PART, TO ANY UNAUTHORIZED PERSON OR ENTITY NOR REPRODUCED, TRANSFERRED OR INCORPORATED IN ANY OTHER PROJECT IN ANY MANNER WITHOUT THE EXPRESS WRITTEN CONSENT OF SAMTEC, INC.

DO NOT SCALE DRAWING

SHEET SCALE: 1:5



520 PARK EAST BLVD, NEW ALBANY, IN 47150
PHONE: 812-944-6733 FAX: 812-948-5047
e-Mail: info@SAMTEC.com code: 55322

DESCRIPTION:
PANEL MOUNT SEALED MINI USB CABLE

DWG. NO.
SCRUS-10-X-XX.XX-XXX-XX

BY: B. PERRY 09-01-2010 SHEET 8 OF 10

**-MBS -BM END OPTION
IN-PROCESS 1**
STRIP OUTER JACKET TO DIMENSION SHOWN

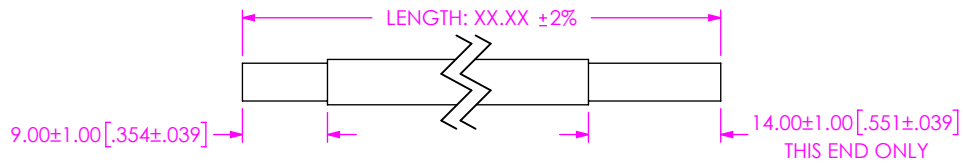

**-MBS -BM END OPTION
IN-PROCESS 2**
TWIST SHIELD & TRIM INDIVIDUAL WIRES

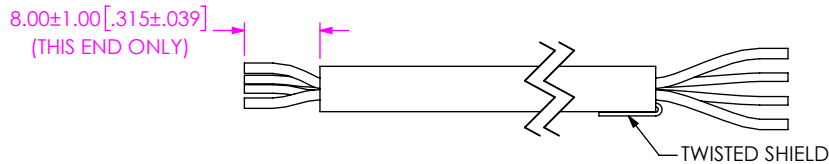

**-MBS -BM END OPTION
IN-PROCESS 3**
STRIP INDIVIDUAL WIRES TO DIMENSION SHOWN

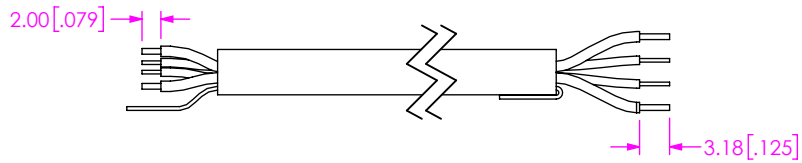

**-MBS -BM END OPTION
IN-PROCESS 4**
TERMINATE TO MUSB-05-G-B-C & SUB-USB-B-G-B-01
(SEE NOTE 19)

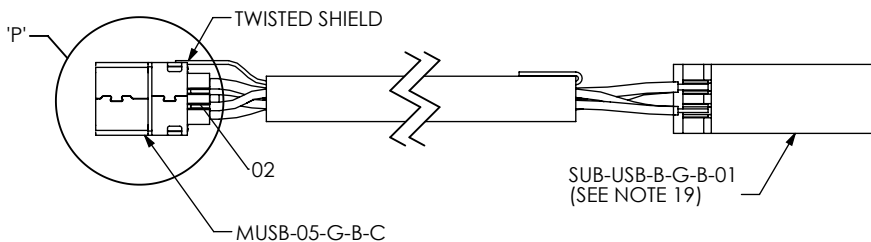
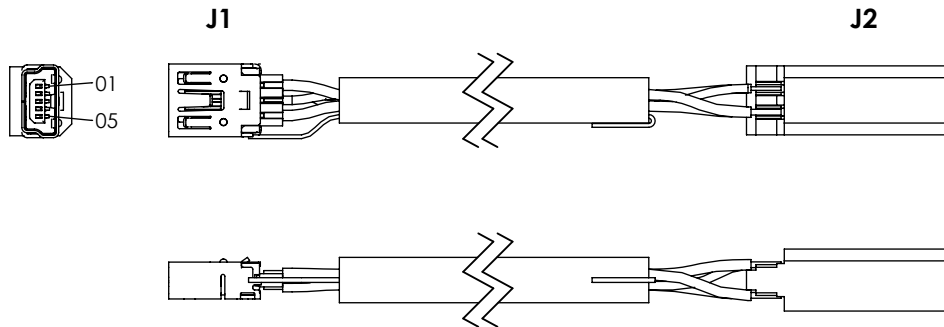

**-MBS -BM END OPTION
IN-PROCESS 5**
ADD USBS-B-N-01-01 SHELL (SEE NOTE 19)

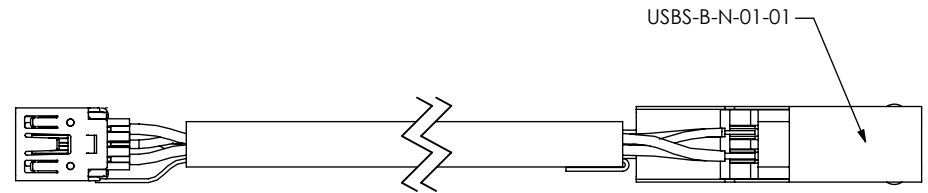

**-MBS -BM END OPTION
IN-PROCESS 6**
ADD USBS-B-N-02-01 SHELL (SEE NOTE 19)

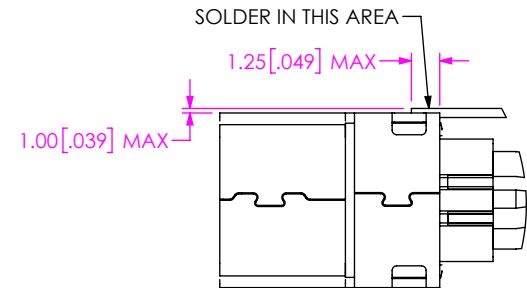
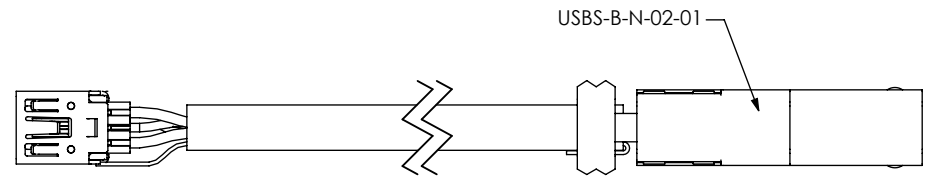

DETAIL 'P'
SCALE 3 : 1

PROPRIETARY NOTE
THIS DOCUMENT CONTAINS CONFIDENTIAL AND PROPRIETARY INFORMATION AND ALL DESIGN, MANUFACTURING, REPRODUCTION, USE, PATENT RIGHTS AND SALES RIGHTS ARE EXPRESSLY RESERVED BY SAMTEC, INC. THIS DOCUMENT SHALL NOT BE DISCLOSED, IN WHOLE OR PART, TO ANY UNAUTHORIZED PERSON OR ENTITY NOR REPRODUCED, TRANSFERRED OR INCORPORATED IN ANY OTHER PROJECT IN ANY MANNER WITHOUT THE EXPRESS WRITTEN CONSENT OF SAMTEC, INC.

DO NOT SCALE DRAWING

SHEET SCALE: 1:5



520 PARK EAST BLVD, NEW ALBANY, IN 47150
PHONE: 812-944-6733 FAX: 812-948-5047
e-Mail: info@SAMTEC.com code: 55322

DESCRIPTION:
PANEL MOUNT SEALED MINI USB CABLE

DWG. NO.
SCRUS-10-X-XX.XX-XXX-XX

BY: B. PERRY 09-01-2010 SHEET 9 OF 10

-MBS -BM END OPTION
IN-PROCESS 7
CRIMP SHELL OVERBAND

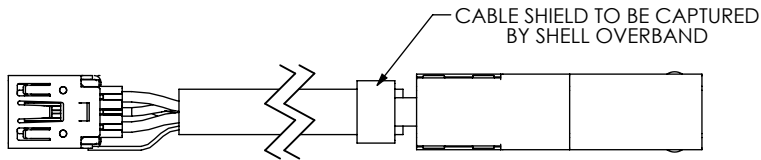

-MBS -BM END OPTION
IN-PROCESS 8
ADD MINI USB B PREMOLD, SAME AS -MB IN-PROCESS 8

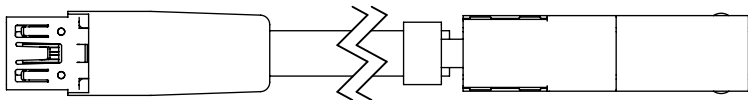

-MBS -BM END OPTION
IN-PROCESS 9
ADD MINI USB B OVERMOLD, SAME AS -MB IN-PROCESS 9

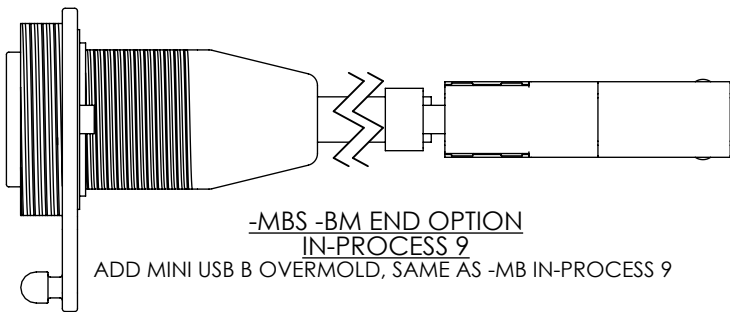

-MBS -BM END OPTION
IN-PROCESS 10
ADD USB B OVERMOLD

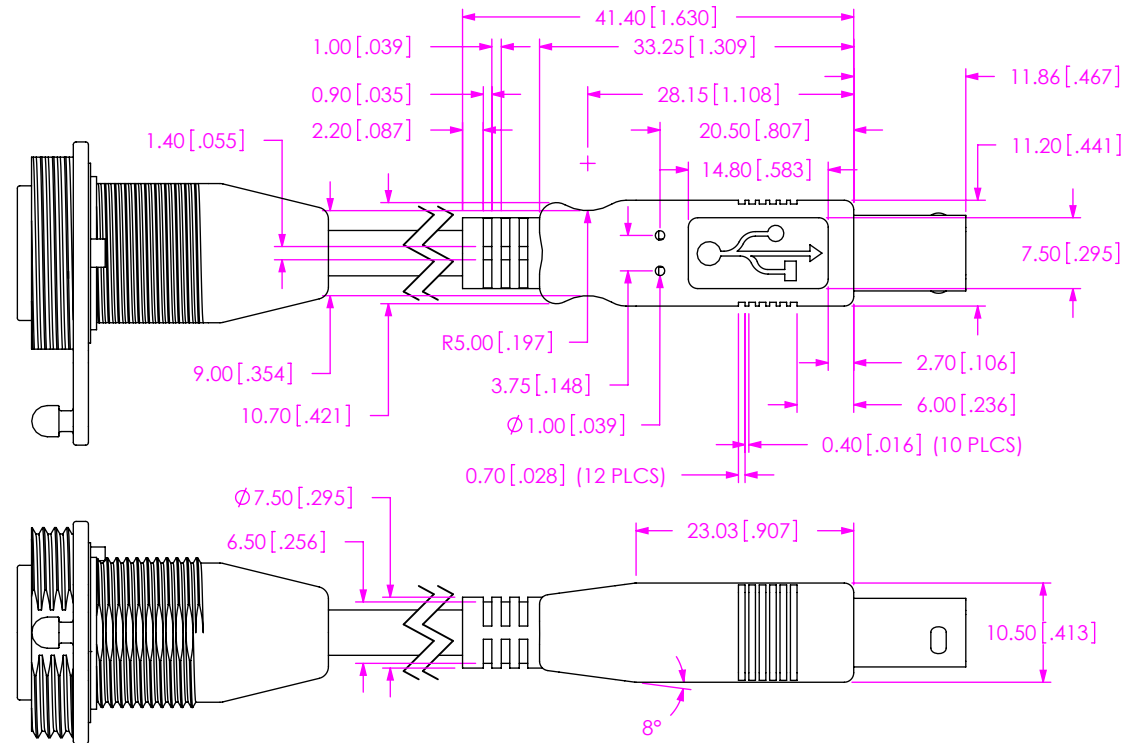

-MBS -BM END OPTION
IN-PROCESS 11
ADD SPG-10-01 & SPN-10-01 & OR-10-01

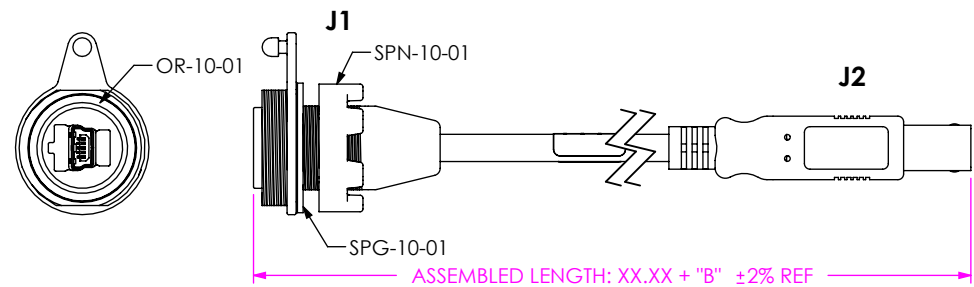

PROPRIETARY NOTE
THIS DOCUMENT CONTAINS CONFIDENTIAL AND PROPRIETARY INFORMATION AND ALL DESIGN, MANUFACTURING, REPRODUCTION, USE, PATENT RIGHTS AND SALES RIGHTS ARE EXPRESSLY RESERVED BY SAMTEC, INC. THIS DOCUMENT SHALL NOT BE DISCLOSED, IN WHOLE OR PART, TO ANY UNAUTHORIZED PERSON OR ENTITY NOR REPRODUCED, TRANSFERRED OR INCORPORATED IN ANY OTHER PROJECT IN ANY MANNER WITHOUT THE EXPRESS WRITTEN CONSENT OF SAMTEC, INC.

DO NOT SCALE DRAWING

SHEET SCALE: 1:5



520 PARK EAST BLVD, NEW ALBANY, IN 47150
PHONE: 812-944-6733 FAX: 812-948-5047
e-Mail: info@SAMTEC.com code: 55322

DESCRIPTION:
PANEL MOUNT SEALED MINI USB CABLE

DWG. NO.
SCRUS-10-X-XX.XX-XXX-XX

BY: B. PERRY 09-01-2010 SHEET 10 OF 10