



ORIENT DISPLAY

Your Total LCD Solution Provider

Specification for TFT

AFL240240A0-1.3INTM-ANO

Revision V0



A	Orient Display
FL	TFT Type
240240	Resolution 240 x 240
A0	Serial A0
1.3	1.3", Module Dimension 31.0 x 45.0 x 5.0mm
I	IPS Display
N	Top: -20~+70°C; Tstr: -30~+80°C
T	Transmissive
M	Normal Brightness, 300cd/m2
/	Controller ST7789V
ANO	SPI Interface + compatible Arduino



DOCUMENT REVISION HISTORY:

DATE	PAGE	DESCRIPTION
2020.10.3	-	First release

Contents

1. General Specification
2. Mechanical Drawing
3. Block Diagram
4. Interface Pin Function
5. Absolute Maximum Ratings
6. Electrical Characteristics
7. Optical Characteristics
8. Timing Characteristics
9. Standard Specification for Reliability
10. General Precautions
11. Specification of Quality Assurance
12. Packing Method

1. General Specification

Item	Dimension	Unit
Module dimension	31.0 x 45.0 x 5.0(MAX)	mm
View area	24.4 x 24.4	mm
Active area	23.40 x 23.40	mm
Dot pitch	0.0975 x 0.0975	mm
Number of Dots	240(RGB) x 240	dots
LCD TYPE	TFT, Transmissive	
Top Polarizer Type	Glare	
View direction	All View	
Drive IC	ST7789V	
Interface Type	SPI 4-wires	
Backlight Type	2 White LED	
Touch Panel	Not Available	

2. Mechanical Drawing

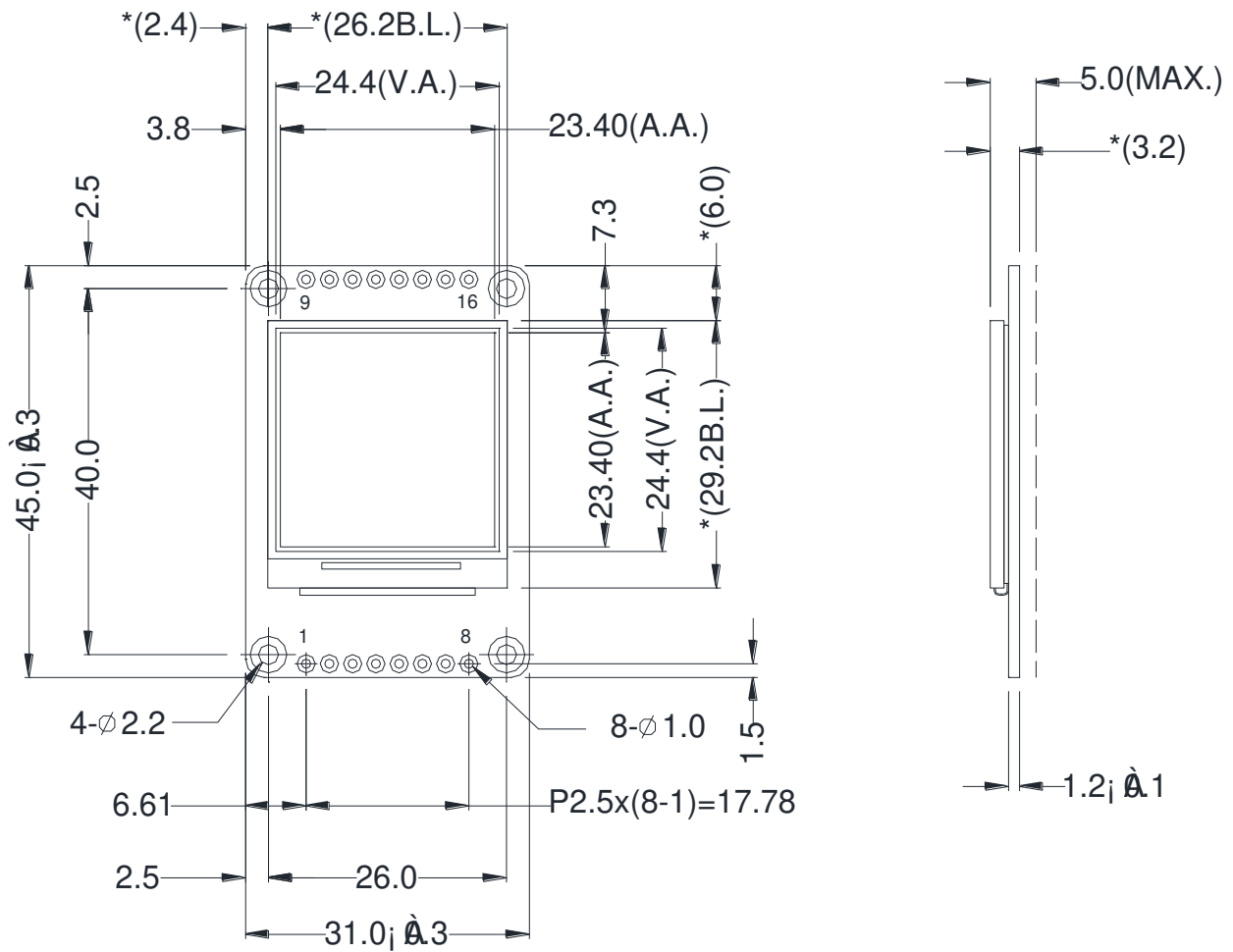

*ST7789V or equivalent

*() dimension for reference only

3. Block Diagram

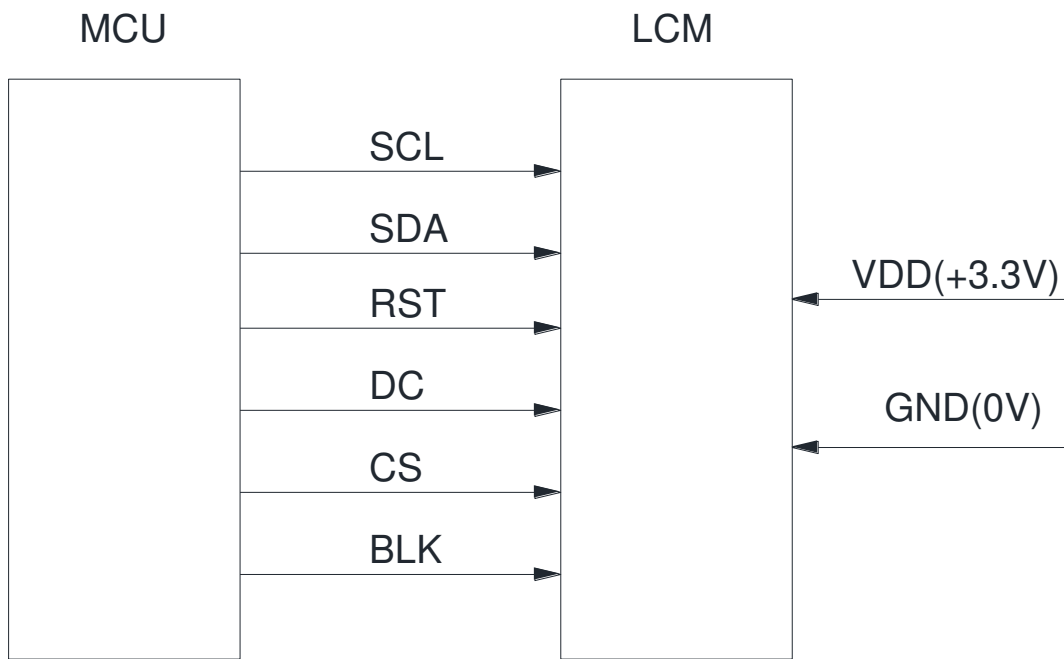

4. Interface Pin Function

Pin No.	Symbol	Level	Description
---------	--------	-------	-------------

1	GND	0V	Ground
2	V _{DD}	3.3V	Supply Voltage for logic
3	SCL	H/L	Serial Clock
4	SDA	H/L	Serial Data
5	RST	H/L	Reset, signal is active low
6	DC	H/L	H:Display data or Parameter, L:Command Data
7	CS	H/L	Chip Select, signal is active low
8	BLK	H/L	Backlight control, H:turn on ,L: turn off

5. Absolute Maximum Ratings

Item	Symbol	Min	Max	Unit
Supply Voltage	V _{DD}	-0.3	4.6	V
Input Voltage(logic input)	V _{In}	-0.3	V _{DD} +0.5	V
Operating Temperature	T _{op}	-20	70	°C
Storage Temperature	T _{str}	-30	80	°C

Note: The absolute maximum rating values of this product are not allowed to be exceeded at any time. Should a module be used with any of the absolute maximum ratings exceeded, the characteristics of the module may not be recovered, or in an extreme case, the module may be permanently destroyed.

6. Electrical Characteristics

Item	Symbol	Condition	Min	Typ	Max	Unit
Supply Voltage	V _{DD}	—	2.7	3.3	3.6	V

Input Voltage for Logic	V_{io}	-	0	-	3.6	V
Input High Volt.	V_{IH}	—	$0.7 V_{DD}$	—	V_{DD}	V
Input Low Volt.	V_{IL}	—	V_{SS}	—	$0.3 V_{DD}$	V

7. Optical Characteristics

Item		Symbol	Condition	Min	Typ	Max	Unit
Luminance		L	—	300	—	—	Cd/m ²
Contrast Ratio		CR	$\theta=0^\circ$	—	500:1	—	—
Response Time		T on	25°C	—	30	-	ms
		T off					
Color Filter Chromacicity	White	W_x		0.255	-	0.330	
		W_y		0.255	-	0.330	
	Red	R_x					
		R_y					
	Green	G_x					
		G_y					
	Blue	B_x					
		B_y					
Viewing angle	Hor.	Θ_{x-}	CR>10	--	80	--	
		Θ_{x+}		--	80	--	
	Ver.	Θ_{y+}		--	80	--	
		Θ_{y-}		--	80	--	
Uniformity		Un	—	80	-	—	%

Note1:Definition of Viewing Angle θ_x and θ_y :

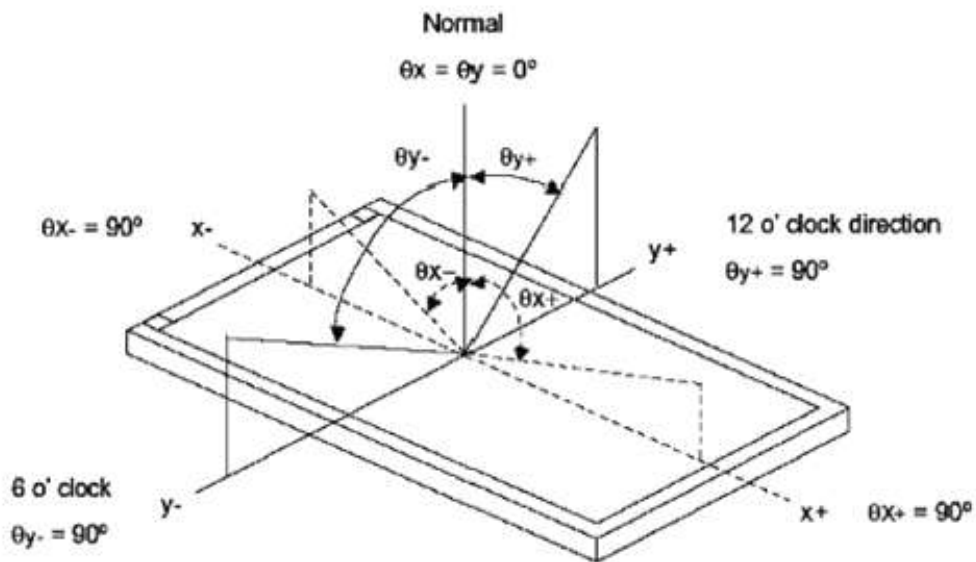

Note 2: Definition of contrast ratio CR:

$$CR = \frac{\text{Luminance of white state}}{\text{Luminance of black state}}$$

Note 3: Definition of Response Time (T_r, T_f):

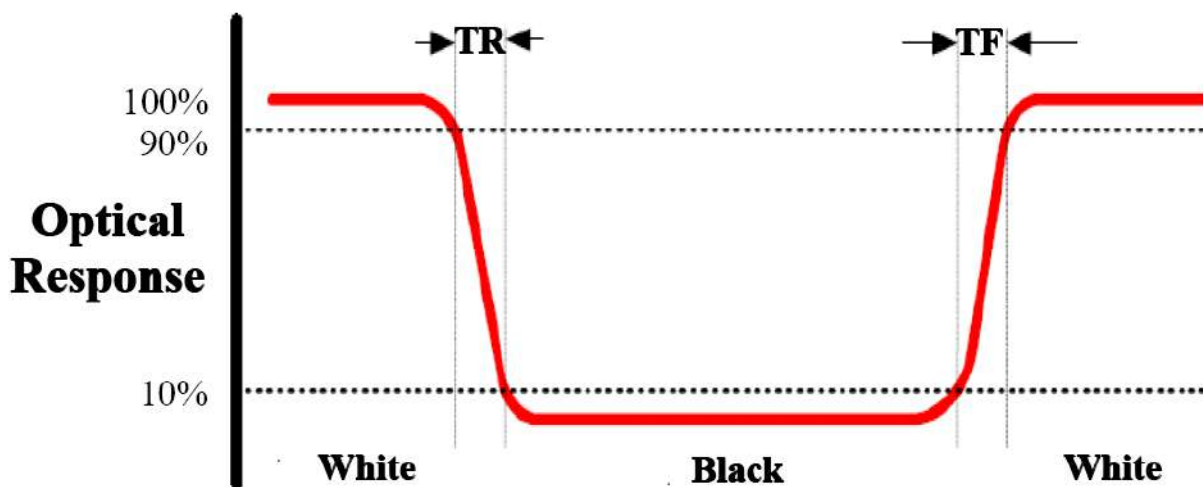

Note 4: Definition of Luminance:

① The Brightness Test Equipment Setup

Field=2°(As measuring “black” image, field=2°is the best testing condition)

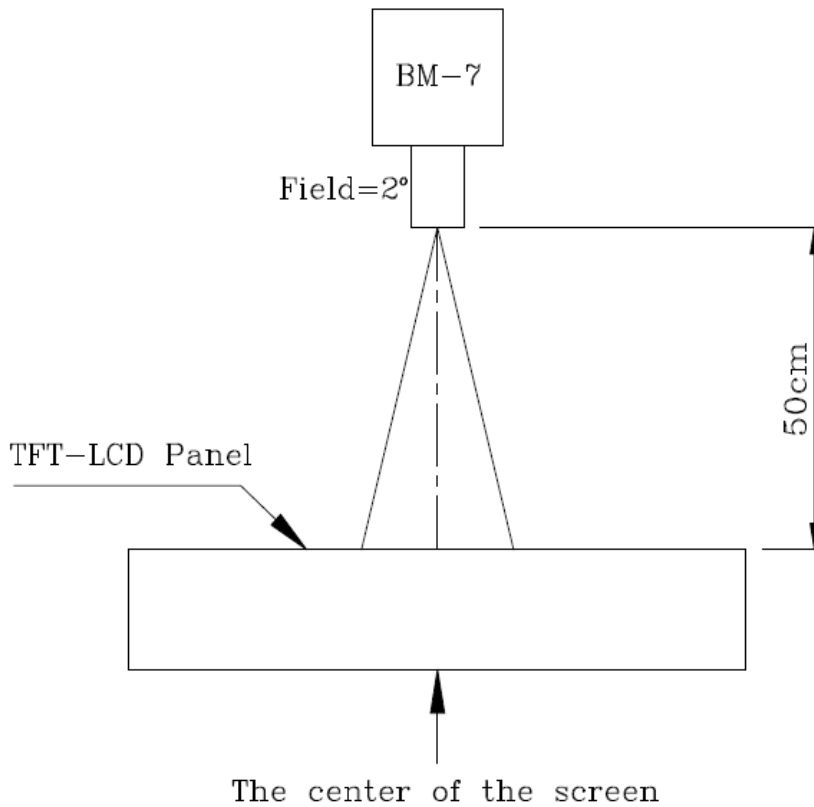

② The Brightness Test Point Setup

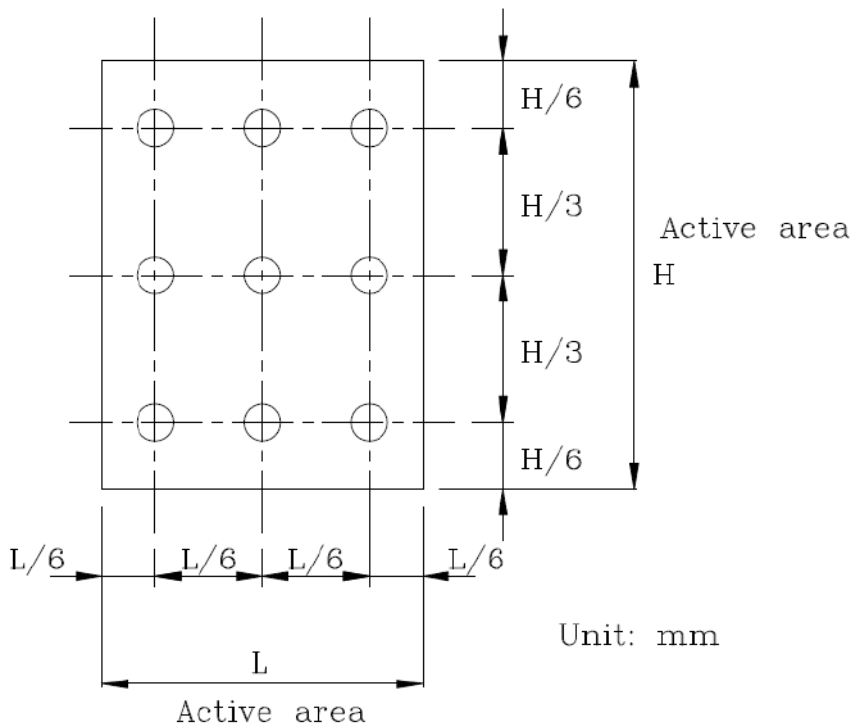

8. Timing Characteristics

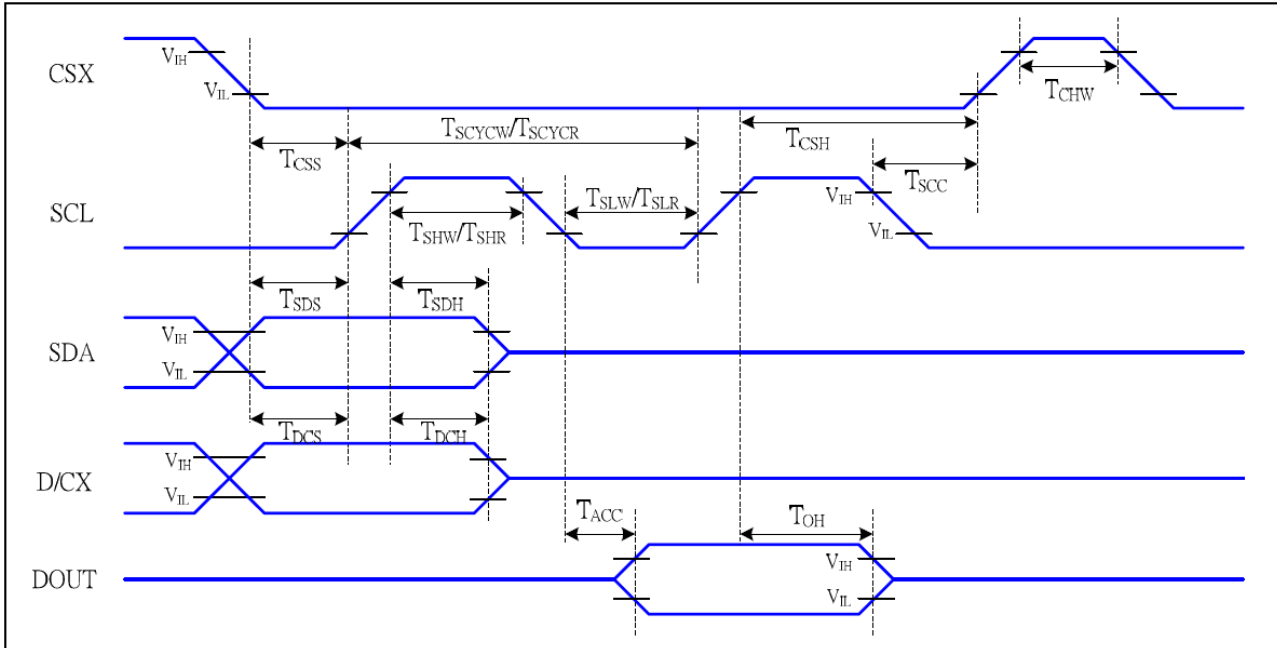

Signal	Symbol	Parameter	MIN	MAX	Unit	Description
CSX	T_{CSS}	Chip select setup time (write)	15		ns	
	T_{CSH}	Chip select hold time (write)	15		ns	
	T_{CSS}	Chip select setup time (read)	60		ns	
	T_{SCC}	Chip select hold time (read)	65		ns	
	T_{CHW}	Chip select "H" pulse width	40		ns	
SCL	T_{SCYCW}	Serial clock cycle (Write)	66		ns	-write command & data ram
	T_{SHW}	SCL "H" pulse width (Write)	15		ns	
	T_{SLW}	SCL "L" pulse width (Write)	15		ns	
	T_{SCYCR}	Serial clock cycle (Read)	150		ns	-read command & data ram
	T_{SHR}	SCL "H" pulse width (Read)	60		ns	
	T_{SLR}	SCL "L" pulse width (Read)	60		ns	
D/CX	T_{DCS}	D/CX setup time	10		ns	
	T_{DCH}	D/CX hold time	10		ns	
SDA (DIN)	T_{SDS}	Data setup time	10		ns	
	T_{SDH}	Data hold time	10		ns	
DOUT	T_{ACC}	Access time	10	50	ns	For maximum CL=30pF
	T_{OH}	Output disable time	15	50	ns	For minimum CL=8pF

9. Standard Specification for Reliability

9.1 Standard Specification for Reliability of LCD Module

No	Test Item	Condition	Remarks
1	High Temperature Operation	Ts = +70°C, 96 hours	IEC60068-21:2007 GB2423.2-2008
2	Low Temperature Operation	Ts = -20°C, 96 hours	IEC60068-2-1:2007 GB/2423.1-2008
3	High Temperature Storage	Ta = +80°C, 96 hours	IEC60068-21:2007 GB/2423.2-2008
4	Low Temperature Storage	Ta = -30°C, 96 hours	IEC60068-21:2007 GB/2423.1-2008
5	Storage at High Temperature and Humidity	Ta = +60°C, 90% RH max,48 hours	IEC60068-2-78 :2001 GB/T2423.3—2006
6	Thermal Shock (nonoperation)	-20°C 30 min~+70°C 30 min, Change time:5min, 10 Cycle	Start with cold temperature, End with high temperature, IEC60068-214:1984, GB/2423.22-2002
7	ESD	C=150pF,R=330 Ω ,5point/panel Air: ± 8Kv,5times; Contact: ± 4Kv,5times (Environment:15°C~35°C, 30%~60%.86Kpa~106Kpa)	IEC61000-42:2001 GB/T17626.2-2006
8	Vibration Test	Frequency range:10~55Hz Stroke:1.5mm Sweep:10Hz~55Hz~10Hz 2 hours for each direction of X.Y.Z (6 hours for total)	IEC60068-2-6:1982 GB/T2423.101995
9	Mechanical Shock (Non Op)	Half Sine Wave60G 6ms, ± X, ± Y, ± Z 3times for each direction	IEC60068-2-27:1987 GB/T2423.5—1995
10	Package Drop Test	Height:80cm, 1corner,3 edges,6 surfaces	IEC60068-2-32:1990 GB/T2423.8—1995

Note1: Ts is the temperature of panel's surface.

Note2: Ta is the ambient temperature of sample.

9.2 Testing Conditions and Inspection Criteria

For the final test, the testing sample must be stored at room temperature for 24 hours. After the tests listed in Table 9.2, standard specifications for reliability will be executed in order to ensure stability.

No.	Item	Test Model	In section Criteria
1	Current Consumption	Refer To Specification	The current consumption should conform to the product specification.
2	Contrast	Refer To Specification	After the tests have been executed, the contrast must be larger than half of its initial value prior to the

			tests.
3	Appearance	Visual inspection	Defect free.

9.3 MTBF

MTBF	Functions, performance, appearance, etc. shall be free from remarkable deterioration within 50,000 hours under ordinary operating and storage conditions room temperature ($25 \pm 5^{\circ}\text{C}$), normal humidity ($50 \pm 10\%$ RH), and in area not exposed to direct sun light.
------	---

10. Specification of Quality Assurance

This standard of Quality Assurance confirms to the quality of LCD module products supplied by ODNA.

10.1 Quality Test

Before delivering, the supplier should conduct the following tests to confirm the quality of products.

Electrical-Optical Characteristics: According to the individual specification to test the product.

Appearance Characteristics: According to the individual specification to test the product.

Reliability Characteristics: According to the definition of reliability on the specification for testing products.

10.2 Delivery Test

Before delivering, the supplier should conduct the delivery test.

Test method: According to MIL-STD105E. General Inspection Level II take a single Time.

The defects classify of AQL as following:

Major defect: AQL = 0.65

Minor defect: AQL = 1.5

Total defects: AQL = 1.5

10.3 Non-conforming Analysis & Deal With Manners

10.3.1 Non-conforming Analysis

Purchaser should provide the data detail of non-conforming sample and the non-conforming.

After receiving the data detail from purchaser, the analysis of non-conforming should be finished within two weeks.

If the analysis can't be finished on time, supplier must notice purchaser 3 days in advance.

10.3.2 Disposition of non-conforming

If any product defect be found during assembling, supplier must change the good for every defect after confirmation.

Both supplier and customer should analyze the reason and discuss the disposition of non-conforming when the reason of nonconforming is not sure.

10.4 Agreement items

Both parties should negotiate together when the following problems happen. There is any problem of standard of quality assurance, and both sides should agree that it must be modified.

There is any argument item which does not record in the standard of quality assurance.

Any other special problem.

10.5 Standard of The Product Appearance Test

10.5.1 Manner of appearance test

The test must be under 20W × 2 or 40W fluorescent light, and the distance of view must be at 30±5cm.

When test the model of transmissive product must add the reflective plate.

The test direction is base on around 10° of vertical line.

Temperature: 25±5°C Humidity: 60±10%RH

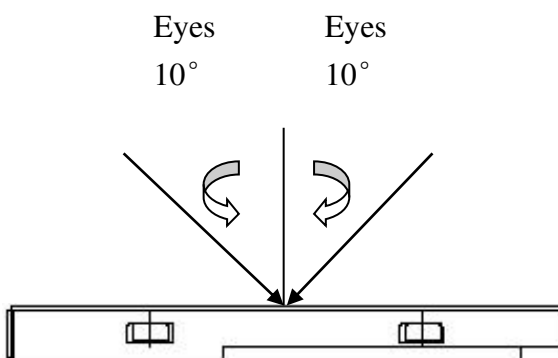

Definition of area:

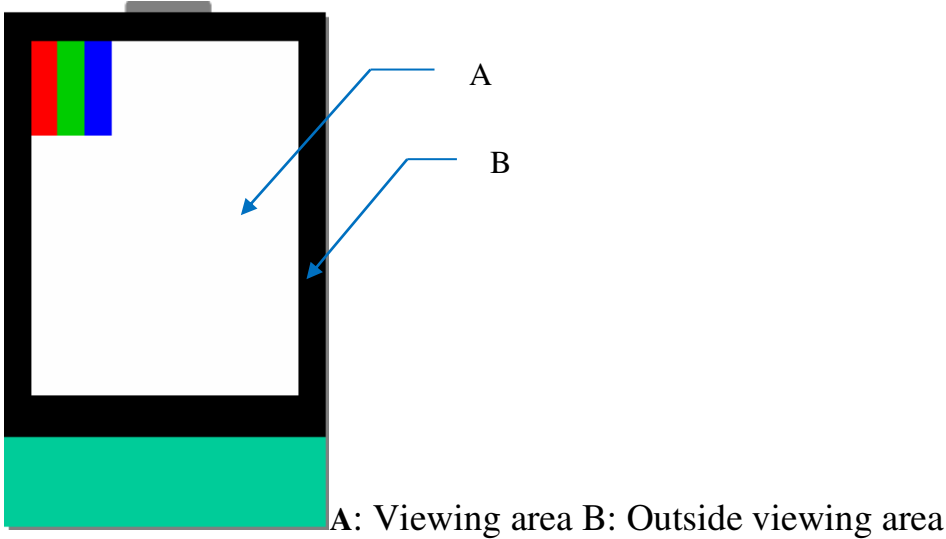

10.5.2 Basic principle

When the standard can not be described, AQL will be applied.

The sample of the lowest acceptable quality level must be negotiated by both supplier and customer when any dispute happened.

New item must be added on time when it is necessary.

10.6 Inspection Specification

NO.	Item	Criterion	AQL
1	Electrical Testing	1.1 Missing vertical, horizontal segment, segment contrast defect. 1.2 Missing character, dot or icon. 1.3 Display malfunction. 1.4 No function or no display. 1.5 Current consumption exceeds product specifications. 1.6 LCD viewing angle defect. 1.7 Mixed product types. 1.8 Flicker	0.65
2	Black or White spots or Bright spots or Color spots on LCD (Display only)	2.1 White and black or color spots on display $\cong 0.25\text{mm}$, no more than Five spots. 2.2 Densely spaced: No more than three spots within 3mm.	1.5
3	LCD and Touch Panel black spots,	3.1 Round type: As following drawing $\Phi = (X+Y) / 2$	1.5

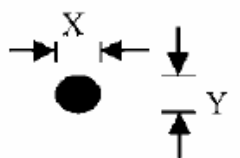
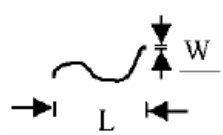
white spots, contamination (non - display)		Size(mm)	Acceptable Q'ty	
		$\Phi \leq 0.10$	Accept no dense	
$0.10 < \Phi \leq 0.20$	2			
$0.20 < \Phi \leq 0.25$	2			
$0.25 < \Phi \leq 0.30$	1			
		$0.30 < \Phi$	0	
* Densely spaced: No more than two spots within 3mm.				1.5
3.2 Line type: (As following drawing)				
		Length(mm)	Width(mm)	Acceptable Q'ty
		---	$W \leq 0.02$	Accept no dense
		$L \leq 3.0$	$0.02 < W \leq 0.05$	2
		$L \leq 2.5$	$0.03 < W \leq 0.08$	2
		---	$0.08 < W$	Rejection
* Densely spaced: No more than two lines within 3mm.				

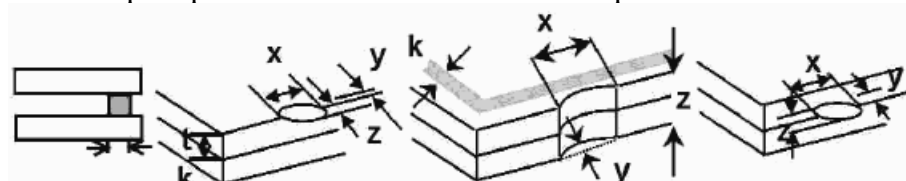
NO.	Item	Criterion			AQL
4	Polarizer bubbles	If bubbles are visible, judge using black spot specifications, not easy to find, must check in specify direction	Size Φ (mm)	Acceptable Q'ty	1.5
			$\Phi \leq 0.30$	Accept no dense	
			$0.30 < \Phi \leq 0.50$	0	
			$0.50 < \Phi \leq 1.00$	0	
			$1.00 < \Phi$	0	
			Total Q' ty	0	
5	Scratches	Follow NO.3 -2 Line Type.			
6	Chipped glass	Symbols: x: Chip length y: Chip width z: Chip thickness k: Seal width t: Glass thickness a: LCD side length L: Electrode pad length			1.5
		6.1 General glass chip: 6.1.1 Chip on panel surface and crack between panels:			
					

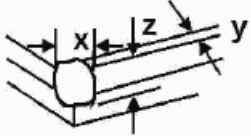
		z: Chip thickness	y: Chip width	x: Chip length
		$Z \leq 1/2t$	Not over viewing area	$x \leq 2MM$
		$1/2t < z \leq 2t$	Not exceed 1/3k	$x \leq 2MM$
		⊙ Unit: mm ⊙ If there are 2 or more chips, x is the total length of each chip		
		6.1.2 Corner crack:		
				
		z: Chip thickness	y: Chip width	x: Chip length
		$Z \leq 1/2t$	Not over viewing area	$x \leq 2MM$
		$1/2t < z \leq 2t$	Not exceed 1/3k	$x \leq 2MM$
		⊙ Unit: mm ⊙ If there are 2 or more chips, x is the total length of each chip		

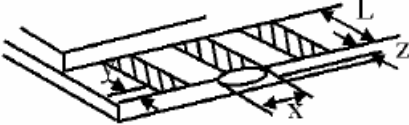
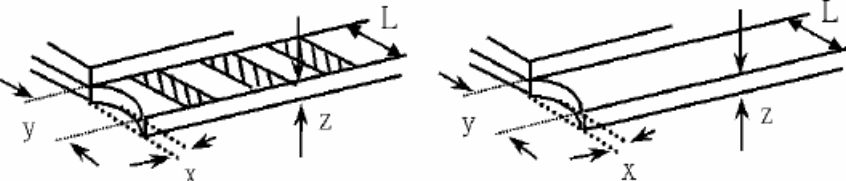
NO.	Item	Criterion	AQL												
7	Glass crack	Symbols: x: Chip length y: Chip width z: Chip thickness k: Seal width t: Glass thickness a: LCD side length L: Electrode pad length 7.2 Protrusion over terminal: 7.2.1 Chip on electrode pad:  <table border="1" data-bbox="422 1617 1332 1697"> <tr> <td>y: Chip width</td> <td>x: Chip length</td> <td>z: Chip thickness</td> </tr> <tr> <td>$y \leq 0.5mm$</td> <td>$x \leq 2MM$</td> <td>$0 < z \leq t$</td> </tr> </table> 7.2.2 Non-conductive portion:  <table border="1" data-bbox="422 1975 1332 2056"> <tr> <td>y: Chip width</td> <td>x: Chip length</td> <td>z: Chip thickness</td> </tr> <tr> <td>$y \leq L$</td> <td>$x \leq 2MM$</td> <td>$0 < z \leq t$</td> </tr> </table>	y: Chip width	x: Chip length	z: Chip thickness	$y \leq 0.5mm$	$x \leq 2MM$	$0 < z \leq t$	y: Chip width	x: Chip length	z: Chip thickness	$y \leq L$	$x \leq 2MM$	$0 < z \leq t$	1.5
y: Chip width	x: Chip length	z: Chip thickness													
$y \leq 0.5mm$	$x \leq 2MM$	$0 < z \leq t$													
y: Chip width	x: Chip length	z: Chip thickness													
$y \leq L$	$x \leq 2MM$	$0 < z \leq t$													

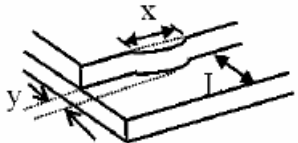
	<p>⊙ If there chipped area touches the ITO terminal, over 2/3 of the ITO must remain and be inspected according to electrode terminal specifications.</p> <p>⊙ If the product will be heat sealed by the customer, the alignment mark must not be damaged.</p> <p>7.2.3 Substrate protuberance and internal crack</p>  <table border="1" data-bbox="778 383 1142 465"> <tr> <td>y: width</td> <td>x: length</td> </tr> <tr> <td>$y \leq 1/3L$</td> <td>$X \leq 2MM$</td> </tr> </table>	y: width	x: length	$y \leq 1/3L$	$X \leq 2MM$	
y: width	x: length					
$y \leq 1/3L$	$X \leq 2MM$					

NO.	Item	Criterion	AQL
8	Cracked glass	No crack is allowed.	1.5
9	Backlight elements	9.1 Illumination source flickers when lit. 9.2 Spots or scratches that appear when lit must be judged. Using LCD spot, lines and contamination standards. 9.3 Backlight doesn't light or color is wrong.	1.5 1.5 0.65
10	Bezel	No scratches with $W > 0.1$ and $Length > 2.5mm$.	1.5
11	PCB、COB	11.1 COB seal may not have pinholes larger than 0.2mm or contamination. 11.2 COB seal surface may not have pinholes through to the IC. 11.3 The height of the COB should not exceed the height indicated in the assembly diagram. 11.4 There may not be more than 2mm of sealant outside the seal area on PCB. And there should be no more than three places. 11.5 Parts on PCB must be the same as on the production characteristic chart, There should be no wrong parts, missing parts or excess parts. 11.6 The jumper on the PCB should conform to the product characteristic chart.	1.5 1.5 1.5 1.5 0.65 0.65
12	FPC	FPC damage per IPC guidelines.(IPC-A-610) Nicks or damage along the edges of the flexible printed circuitry and cutouts, providing the penetration does not exceed 50% of the distance from the edge to the nearest conductor to 2.5mm[0.1in], Whichever is less.	1.5

13	Soldering	13.1 No cold solder joints, missing solder connections, oxidation or icicle.	1.5
		13.2 No short circuits in components on PCB or FPC.	1.5
		13.3 Soldering per IPC guidelines.(IPC-A-610)	0.65

NO.	Item	Criterion	AQL												
14	Touch Panel Chipped glass	<p>Symbols: x: Chip length y: Chip width z: Chip thickness k: Seal width t: Touch Panel Total thickness a: LCD side length L: Electrode pad length</p> <p>14.1 General glass chip: 14.1.1 Chip on panel surface and crack between panels:</p> <table border="1"> <tr> <td>z: Chip thickness</td> <td>y: Chip width</td> <td>x: Chip length</td> </tr> <tr> <td>$Z \cong t$</td> <td>$\cong 1/2 k$ and not over viewing area</td> <td>$x \cong 2MM$</td> </tr> </table> <ul style="list-style-type: none"> ⊙ Unit: mm ⊙ If there are 2 or more chips, x is the total length of each chip <p>14.1.2 Corner crack:</p> <table border="1"> <tr> <td>z: Chip thickness</td> <td>y: Chip width</td> <td>x: Chip length</td> </tr> <tr> <td>$Z \cong t$</td> <td>$\cong 1/2 k$ and not over viewing area</td> <td>$x \cong 2MM$</td> </tr> </table> <ul style="list-style-type: none"> ⊙ Unit: mm ⊙ If there are 2 or more chips, x is the total length of each chip 	z: Chip thickness	y: Chip width	x: Chip length	$Z \cong t$	$\cong 1/2 k$ and not over viewing area	$x \cong 2MM$	z: Chip thickness	y: Chip width	x: Chip length	$Z \cong t$	$\cong 1/2 k$ and not over viewing area	$x \cong 2MM$	1.5
z: Chip thickness	y: Chip width	x: Chip length													
$Z \cong t$	$\cong 1/2 k$ and not over viewing area	$x \cong 2MM$													
z: Chip thickness	y: Chip width	x: Chip length													
$Z \cong t$	$\cong 1/2 k$ and not over viewing area	$x \cong 2MM$													

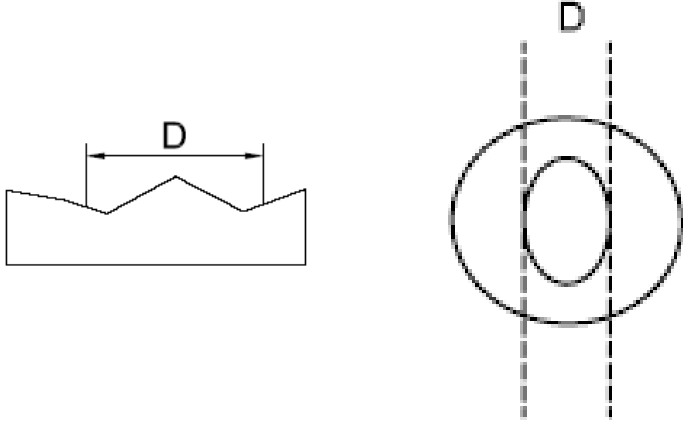
NO.	Item	Criterion	AQL	
15	Touch Panel(Fish eye、dent and bubble on film)	SIZE(mm)	Acceptable Q' ty	
		$\Phi \cong 0.2$	Accept no dense	
		$0.2 < D \cong 0.4$	5	
		$0.4 < D \cong 0.5$		
		$0.5 < D$	0	
			1.5	
16	Touch Panel Newton ring	Newton ring dimension $\cong 1/2$ touch panel area and not affect font and line distortion($\cong 2.5\%$) , it is acceptable.		1.5
17	Touch Panel Linearity	Less than 1.5% is acceptable.		1.5
18	LCD Ripple	Touch the touch panel , can not see the LCD ripple. Pen: R 1.0mm silicon rubber. Operation Force: 80g		1.5
19	General appearance	19.1 Pin type must match type in specification sheet.		0.65
		19.2 LCD pin loose or missing pins.	0.65	
		19.3 Product packaging must the same as specified on packaging specification sheet.	0.65	
		19.4 Product dimension and structure must conform to product specification sheet.	0.65	

11. Handling Precaution

11.1 Handling of LCM

Avoid external shock.

Don't apply excessive force on the surface.

Liquid in LCD is hazardous substance, do not lick or swallow. When the liquid is attaching to your hand, skin, cloth, etc., wash it thoroughly and immediately.

Don't operate it above the absolute maximum rating.

Don't disassemble the LCM.

The operators should wear protections whenever he/she comes into contact with the module. Never touch any of the conductive parts such as the LSI pads, the copper leads on the PCB and the interface terminals with any parts of the human body.

The modules should be kept in antistatic bags or other containers resistant to static for storage.

The module is coated with a film to protect the display surface, be careful when peeling off this protective film since static electricity may be generated.

11.2 Storage

Store it in an ambient temperature of $25\pm 10^{\circ}\text{C}$, and in a relative

humidity of $50\pm 10\% \text{RH}$. Don't expose to sunlight or fluorescent light.

Store it in a clean environment, free from dust, active gas, and solvent.

Store it in anti-static electricity container.

Store it without any physical load.

11.3 Soldering

Use only soldering irons with proper grounding and no leakage.

Iron: no higher than $280\pm 10^{\circ}\text{C}$ and less than 3 sec during hand soldering.

Rewiring: no more than 2 times.

12.PackingMethod

TBD