

REVISIONS				
P	LTR	DESCRIPTION	DATE	OWN APVD
B1		REVISED PER ECR-17-015449	26OCT2017	BDA KR

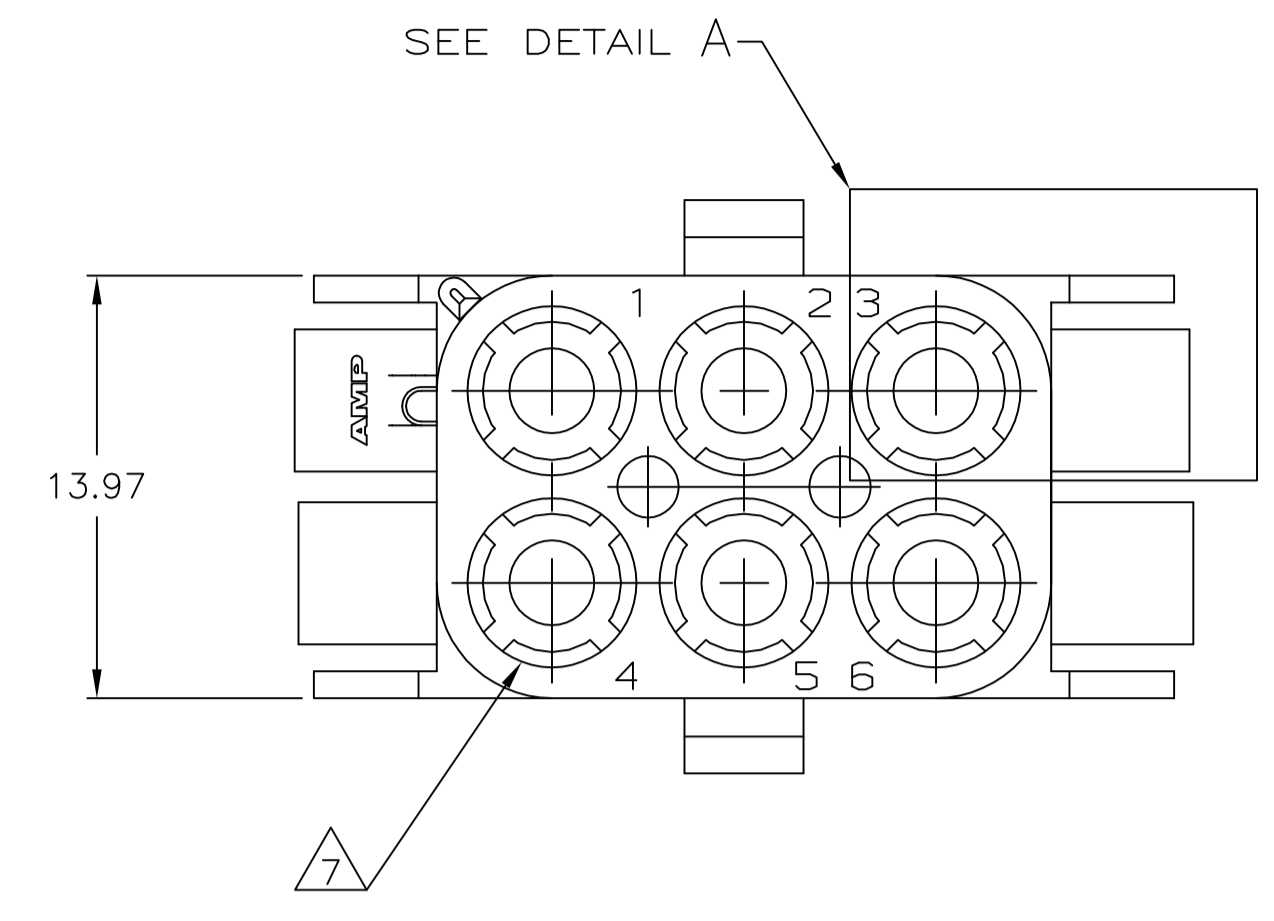

1. MATES WITH APPROPRIATE UNIVERSAL MATE-N-LOK™ PLUG.
2. RECOMMENDED PANEL THICKNESS 0.76 - 2.29.
3. PANEL MUST BE PUNCHED SO THAT THE HOUSING ENTERS THE PANEL IN THE SAME DIRECTION AS THE PUNCH.
4. OPTIONAL FOR KEYING HOUSING IN PANEL.
5. CIRCUIT NUMBER 1 LOCATION.
6. DIMENSIONS SHOWN REPRESENT PRODUCT IN DRY, AS MOLDED, CONDITION. ADDITIONAL 2% GROWTH DUE TO SUBSEQUENT MOISTURE ABSORPTION MAY OCCUR AND SHOULD BE ACCOUNTED FOR.
7. FOUR RIBS EQUALLY SPACED, NO SPECIFIC ORIENTATION. NO RIBS OR SIX RIBS EQUALLY SPACED, NO SPECIFIC ORIENTATION, OPTIONAL.
8. UNDERWRITERS RECOGNIZED COMPONENT LOGO AND CSA CERTIFICATION LOGO TO BE LOCATED ONCE EACH ON SIDE OF HOUSING.
9. FLAMMABILITY V2 FOR THICKNESS 0.38mm, 1.5mm, and 3.0mm PER IEC 60695-11-10.
10. GLOW-WIRE FLAMMABILITY (GWFI) 800°C FOR THICKNESS 0.38mm AND 0.75mm PER IEC 60695-2-12.
11. GLOW-WIRE FLAMMABILITY (GWFI) 960°C FOR THICKNESS 1.5mm AND 3.0mm PER IEC 60695-2-12.
12. GLOW-WIRE IGNITION (GWIT) 825°C FOR THICKNESS 0.38mm, 0.75mm, 1.5mm AND 3.0mm PER IEC 60695-2-13.

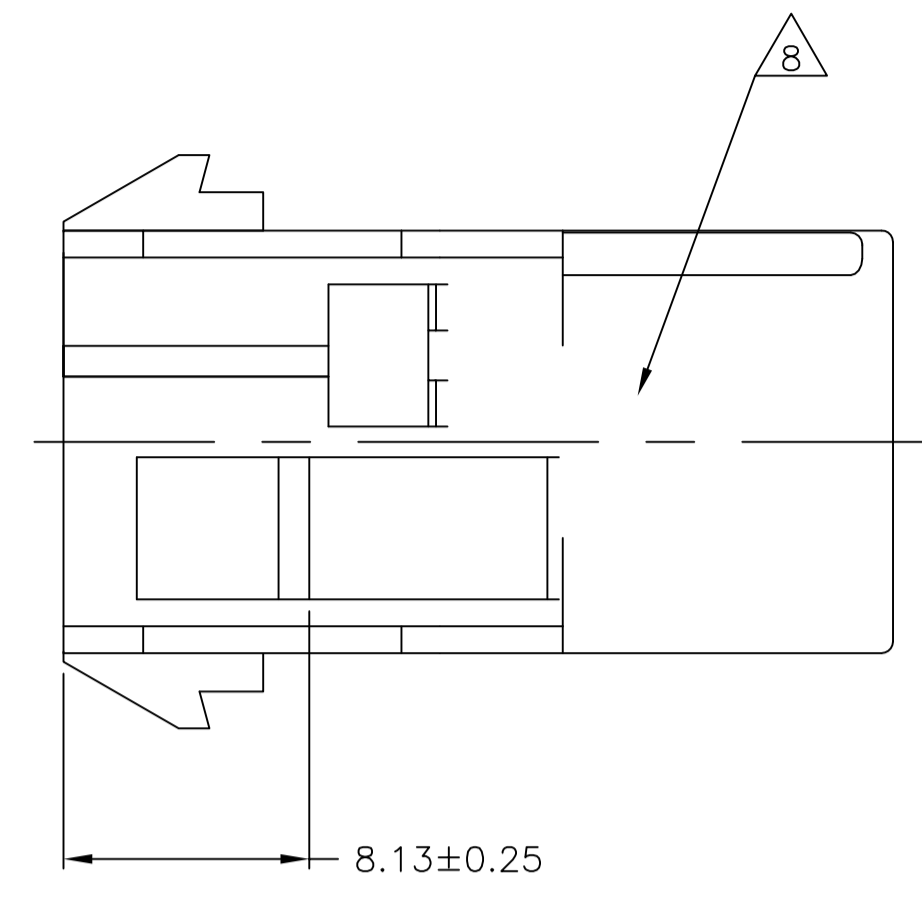
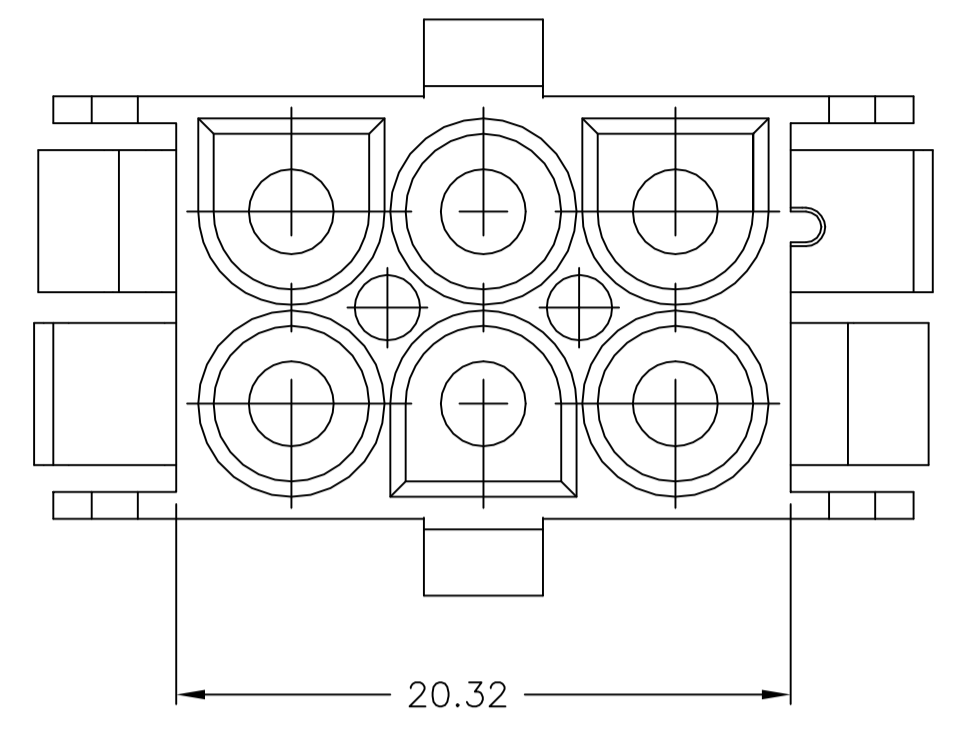
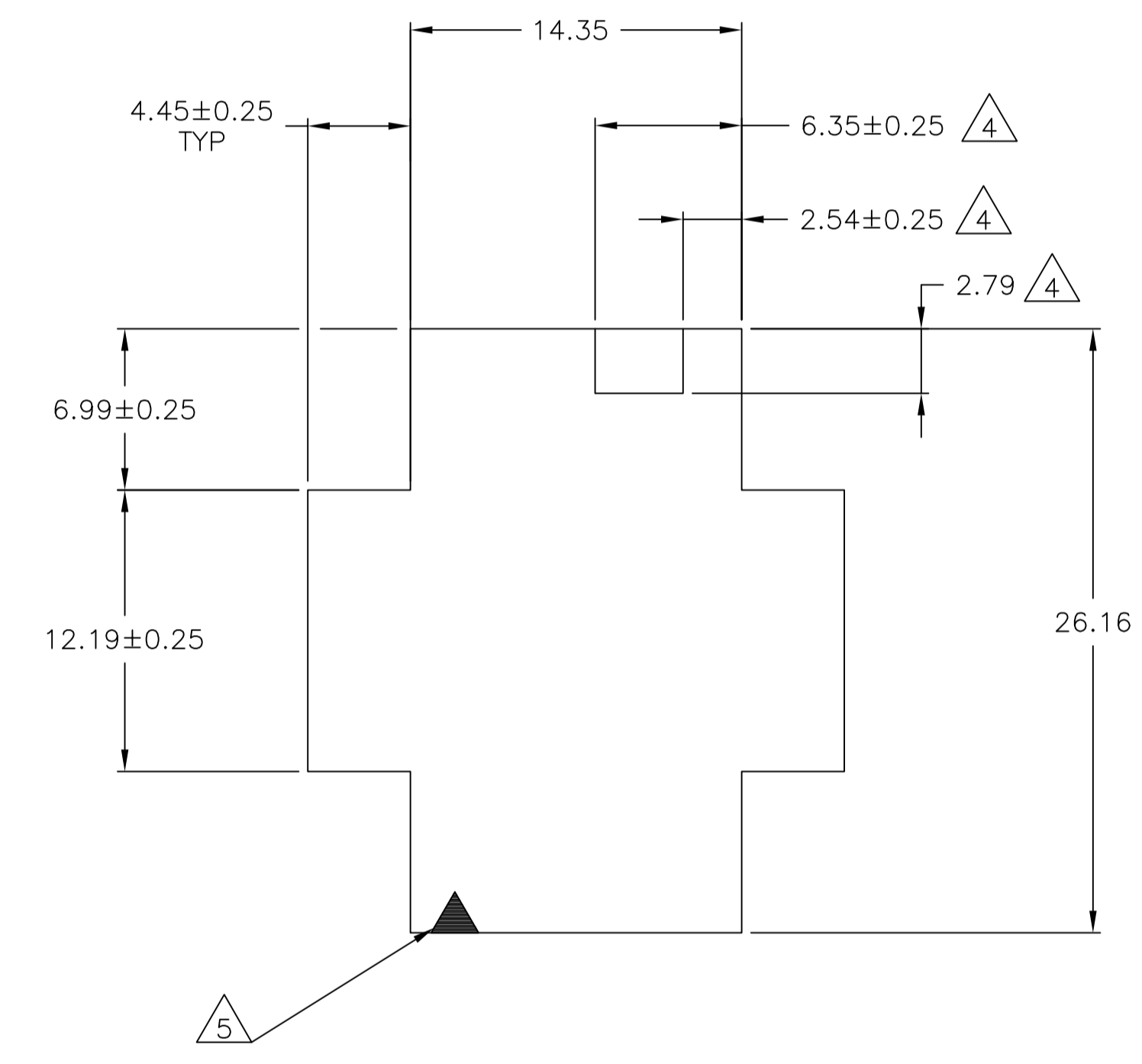
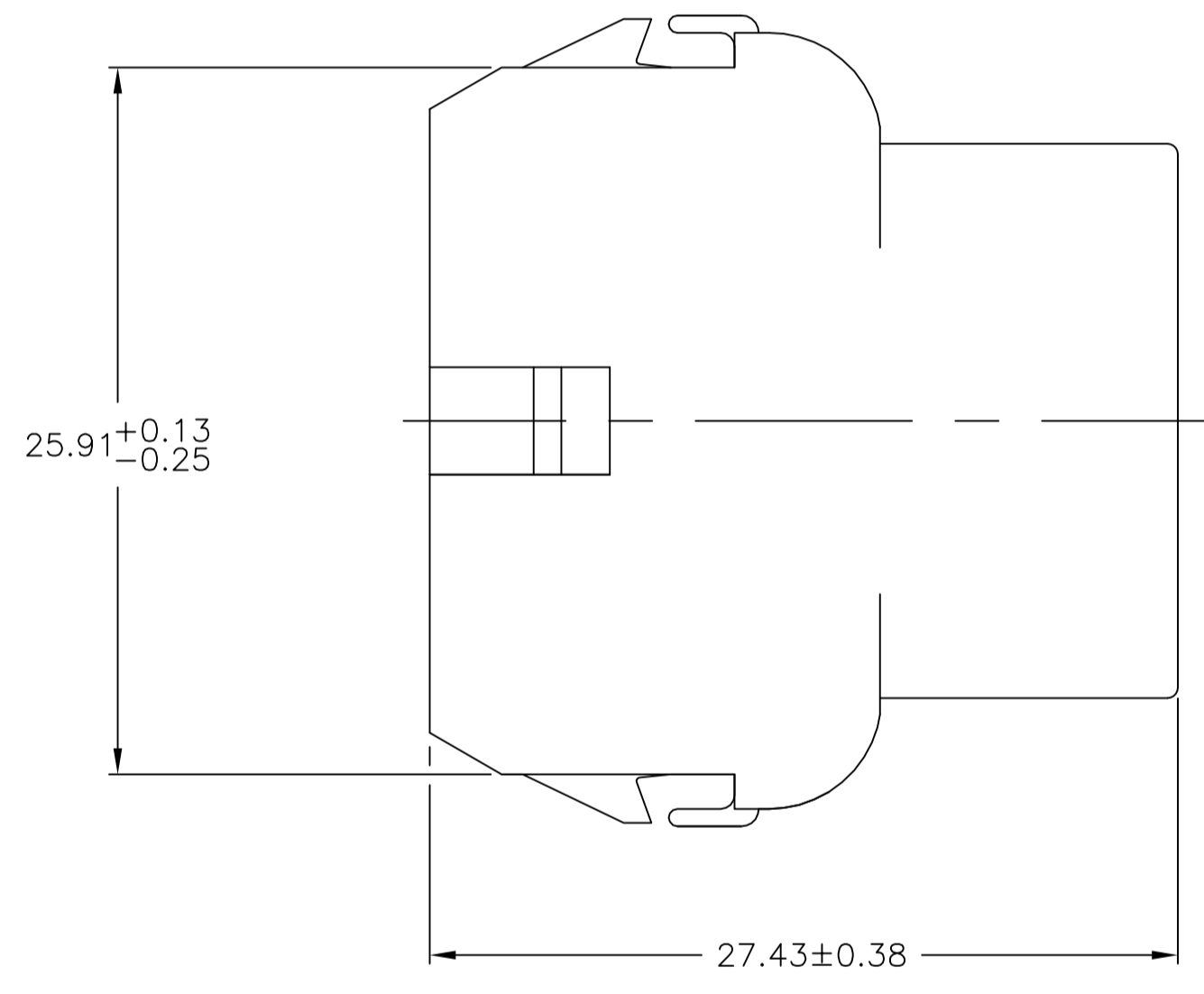
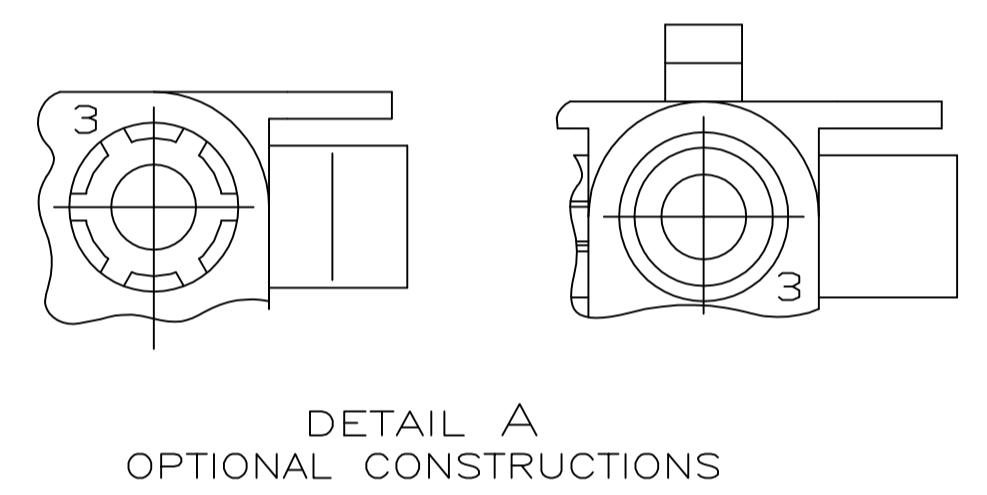

RECOMMENDED PANEL CUT OUT

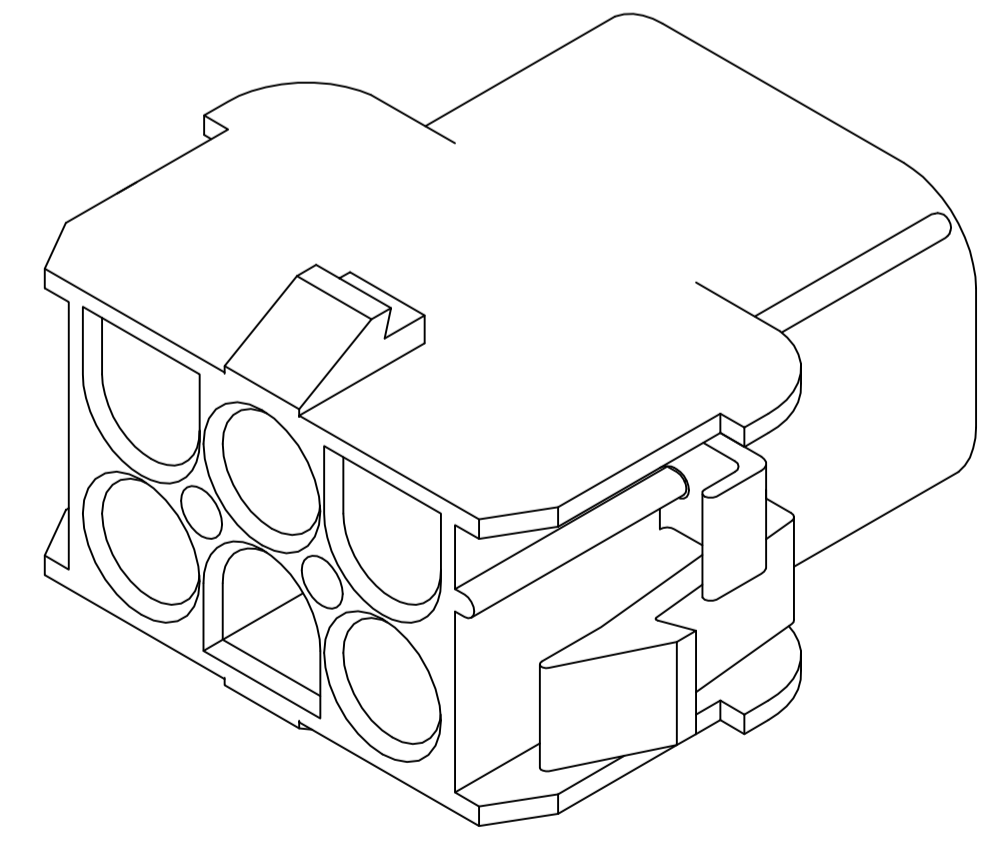

3-DIMENSIONAL MODEL NTS

4.45	.175	27.43	1.080
3	.118	26.16	1.030
2.79	.110	25.91	1.020
2.54	.100	20.32	.800
2.29	.090	14.35	.565
0.76	.030	13.97	.550
0.4	.016	12.19	.480
0.38	.015	8.13	.320
0.25	.010	6.99	.275
0.13	.005	6.35	.250
MM	IN	MM	IN

CONVERSION TABLE

NATURAL	1586860-1
COLOR	PART NUMBER

THIS DRAWING IS A CONTROLLED DOCUMENT.

DIMENSIONS:	TOLERANCES UNLESS OTHERWISE SPECIFIED:	DWN K. WHITAKER 25JUL2007	APVD D. COLEY 25JUL2007
mm	0. PLC ± - 1. PLC ± - 2. PLC ± 0.13 3. PLC ± - 4. PLC ± - ANGLES ± 0°30'	CHK D. COLEY 25JUL2007	NAME D. COLEY 25JUL2007
		APPLICATION SPEC PRODUCT SPEC	
MATERIAL NYLON, UL94V-2	FINISH -	SIZE A1	CAGE CODE 00779
CUSTOMER DRAWING		DRAWING NO 1586860	RESTRICTED TO -
SCALE 4:1		SHEET 1 of 1	REV B1

TE Connectivity

CAP, 6 CIRCUIT, UNIVERSAL MATE-N-LOK(TM)