

SEE DETAIL C SECTION X-X

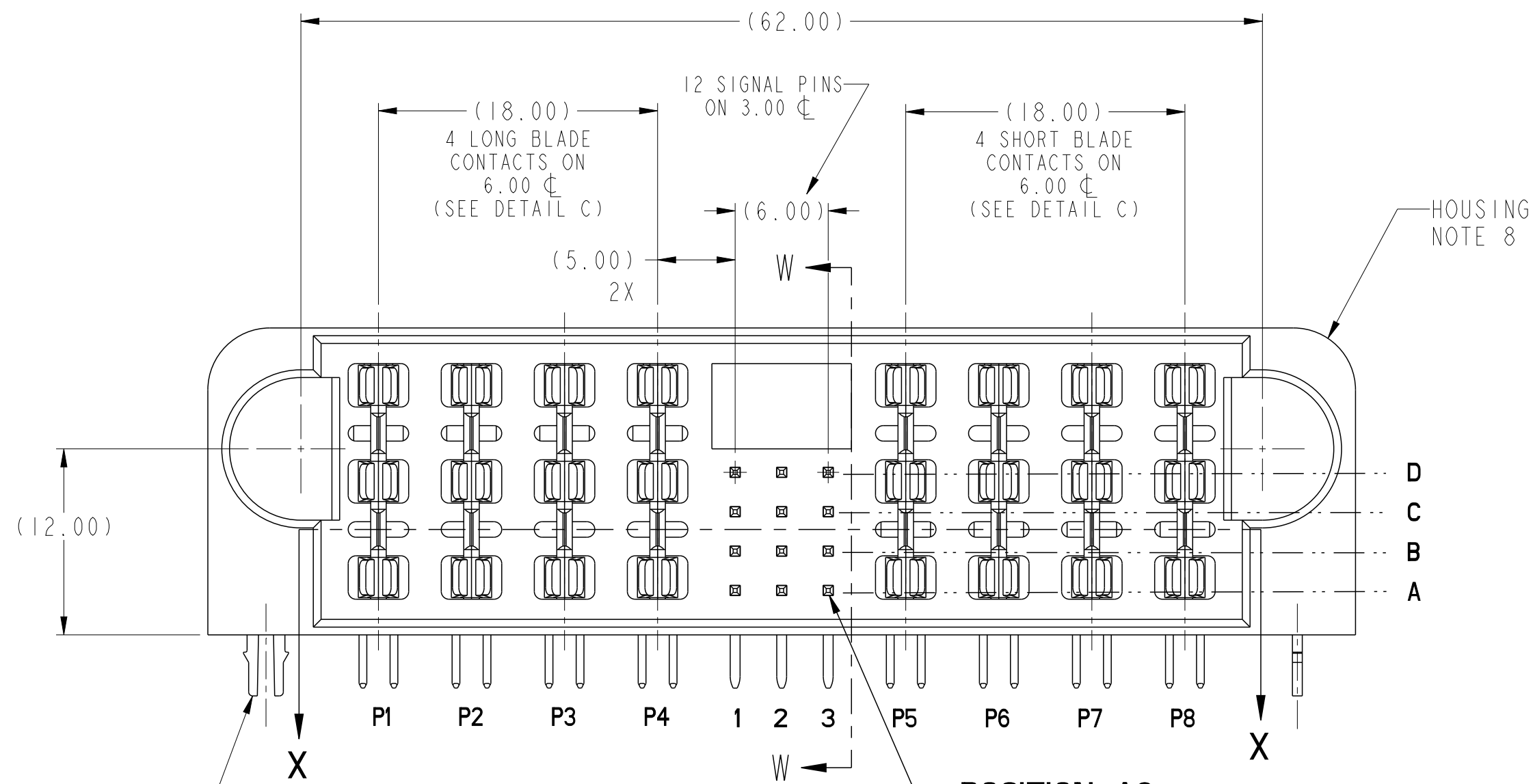

POSITION A3 SHORT DETECT PIN SEE SECTION W-W

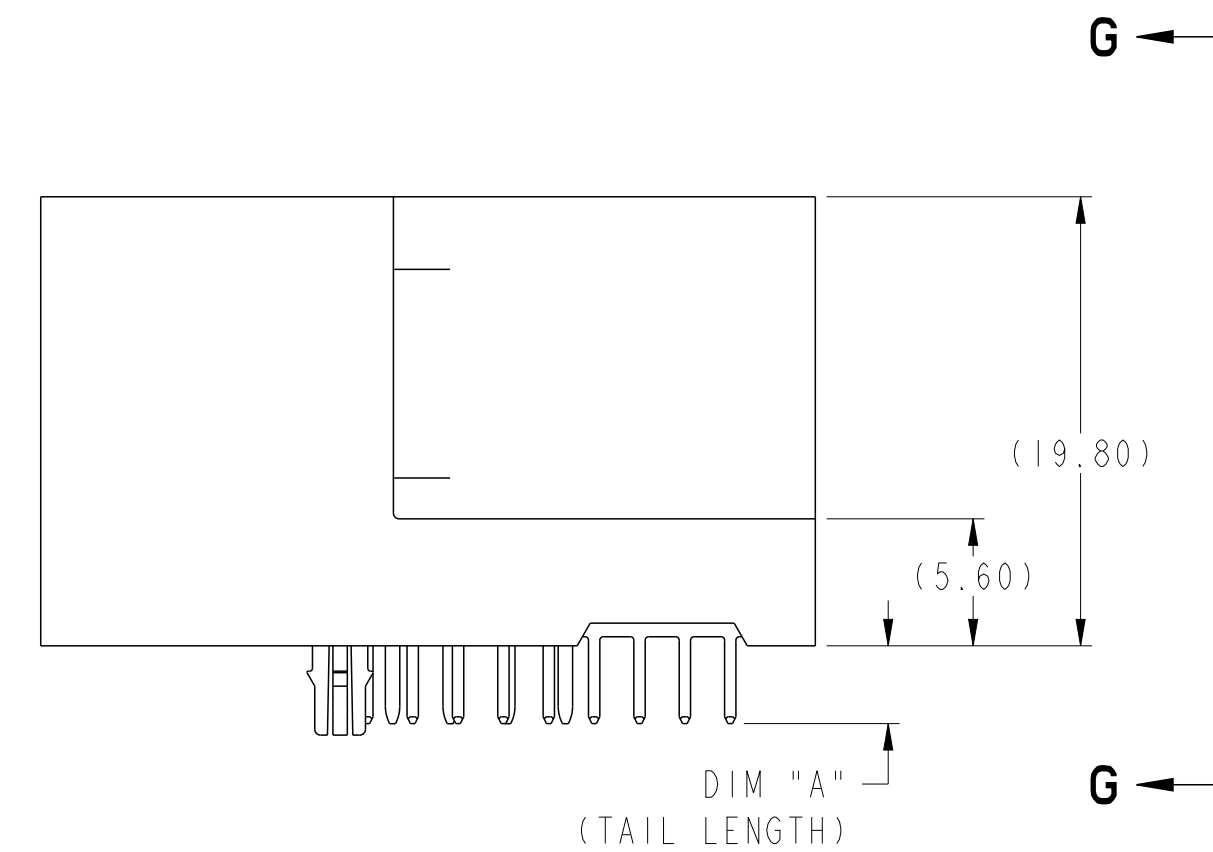

DIM "A" (TAIL LENGTH)

RETENTION CLIPS OPTIONAL (SEE P/N TABLE)

spec ref	*	dr	NotFound DuWa	2010/04/27	projection	MM	size	A2	scale	3:1	
tolerance std	ASME Y14.5	eng	De-Ming Lu	2014/12/28			ecn no	ELX-DG-19849-1			
TOLERANCES UNLESS OTHERWISE SPECIFIED		chr					rel level	Released			
surface	ASME Y14.5	appr	Pei-Ming Zheng				product family	HCI			
linear	0.X ±0.5 0.XX ±0.25 0.XXX ±0.10	www.fci.com	cat. no.		R/A HDR ASSY 4P+12S+4P HCI POWER CONNECTOR		dwg no	10080655		rev	B
angular	0° ±2°	Product - Customer Drw		sheet 1 of 5							

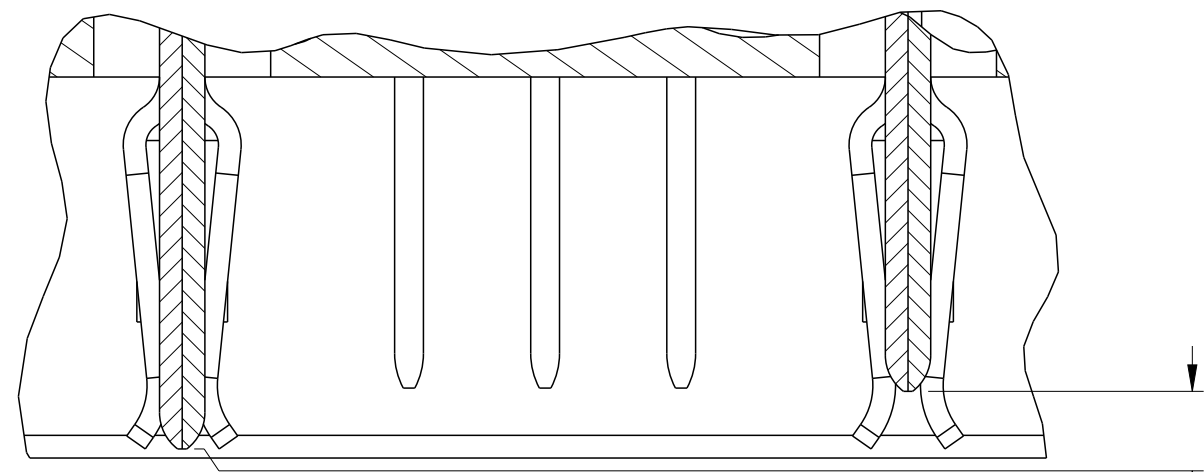

DETAIL C
SCALE 6:1
POWER MATING
SEQUENCE

(1.27)

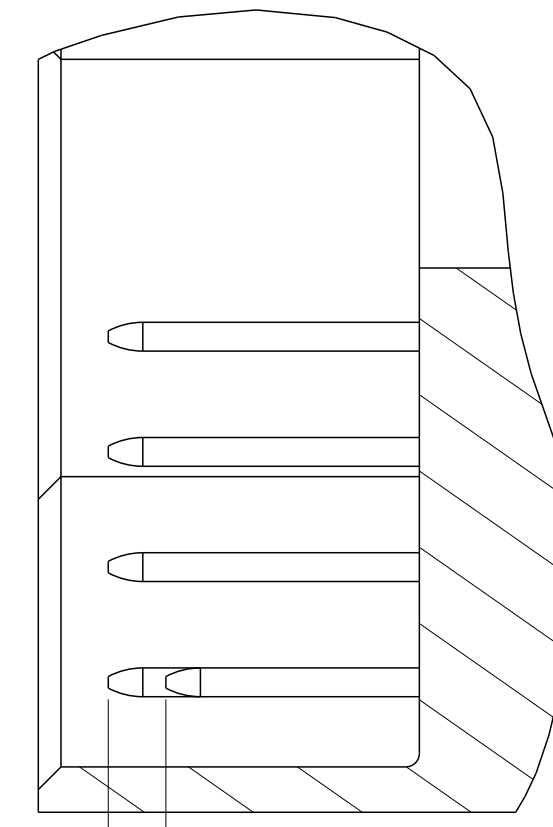

SECTION W-W
SCALE 6:1
SIGNAL MATING
SEQUENCE

(1.27)

KEYED FOR SHORT CONTACTS
4X

KEYED FOR LONG CONTACTS
4X

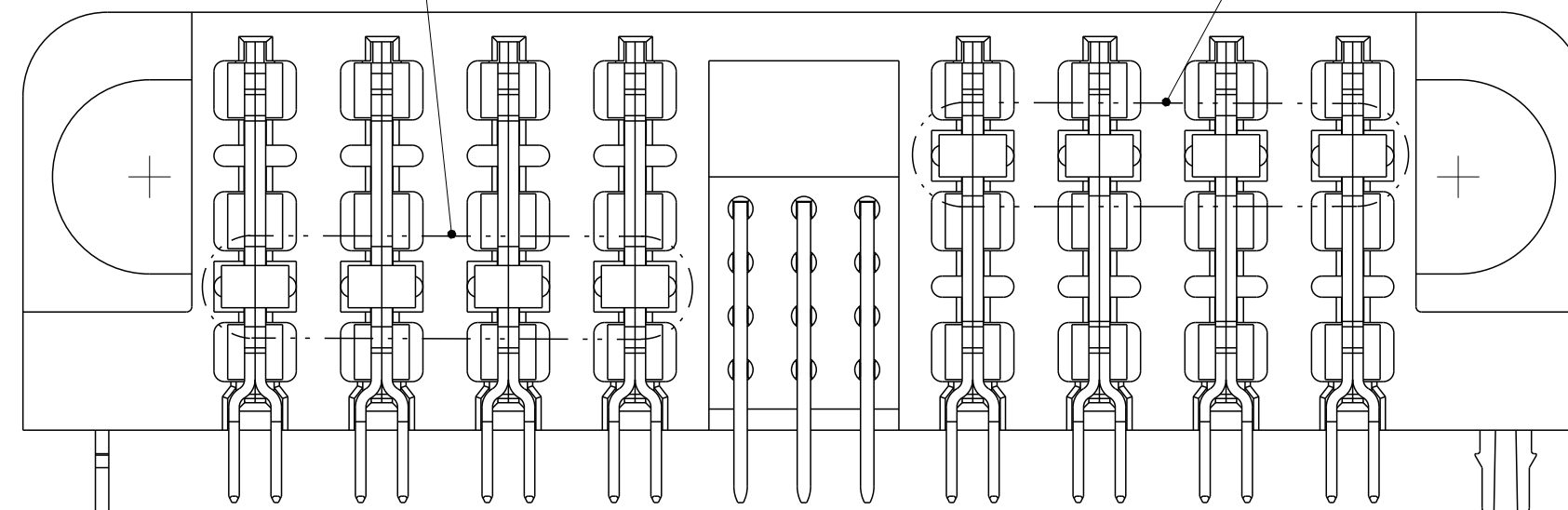

VIEW G-G

dr	NotFound DuWa	2010/04/27	projection	MM	size	A2	scale	3:1
eng	De-Ming Lu	2014/12/28			ecn no	ELX-DG-19849-1		
chr	-	product family			HCI	rel level	Released	
appr	Pei-Ming Zheng	2014/12/29			title	R/A HDR ASSY 4P+12S+4P		rev
			www.fci.com		cat. no.	-		Product - Customer Drw
					dwg no	10080655		B
					sheet 2 of 5			

NOMINAL CONNECTOR OUTLINE

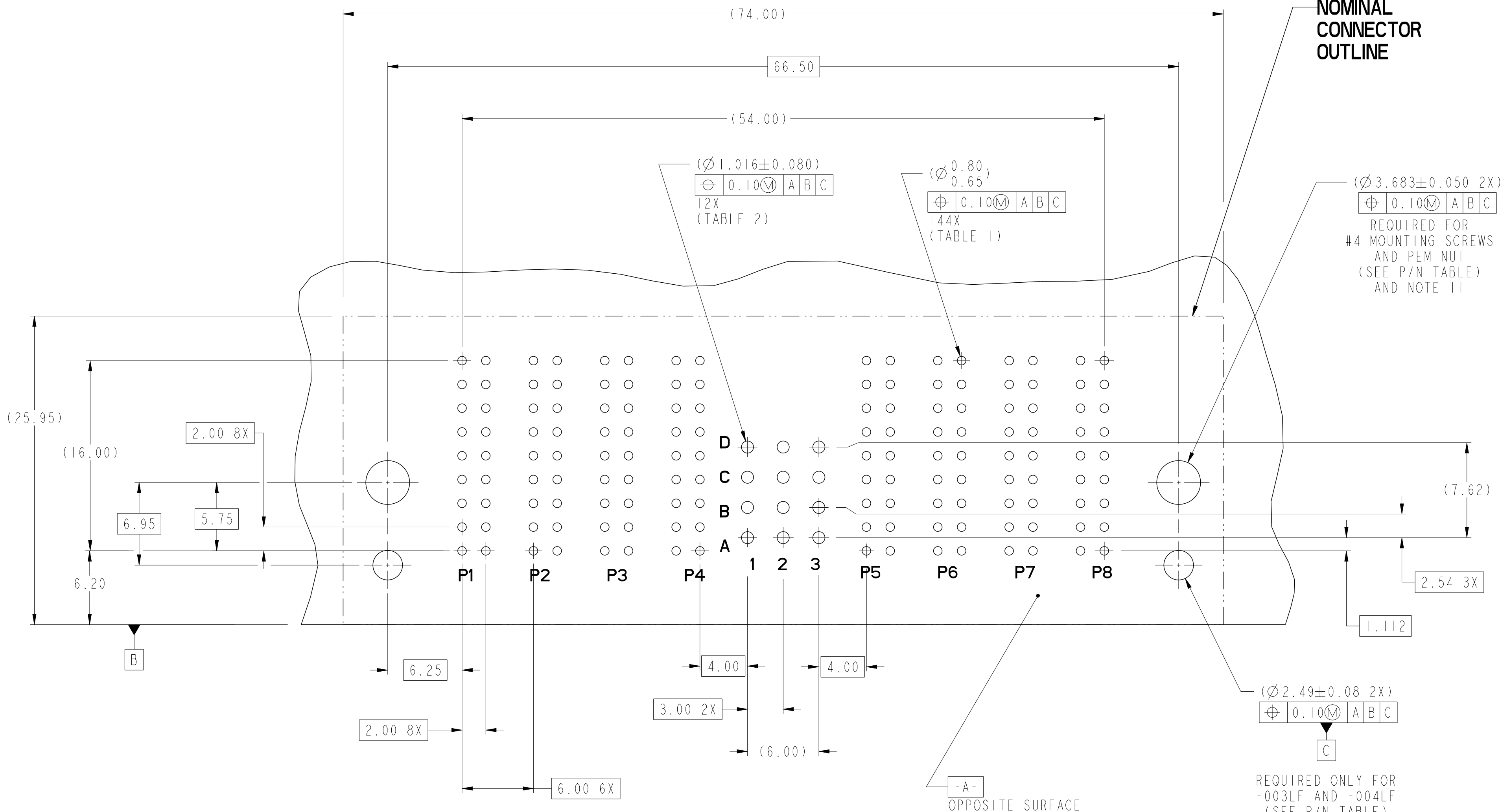

**RECOMMENDED PCB LAYOUT
COMPONENT SIDE**

NOTE 6

dr	NotFound DuWa	2010/04/27	projection	MM	size	A2	scale	4:1
eng	De-Ming Lu	2014/12/28			ecn no	ELX-DG-19849-1		
chr	-	-			rel level	Released		
appr	Pei-Ming Zheng	2014/12/29	product family	-	rel level	Released		
		title R/A HDR ASSY 4P+12S+4P HCI POWER CONNECTOR	dwg no 10080655	rev B				
www.fci.com		cat. no.	Product - Customer Drw		sheet 3 of 5			

A

B

C

D

E

F

A

B

C

D

E

F

TOP LAYER DESCRIPTION

TABLE 1 (HCI POWER)
PLATED THROUGH-HOLE REQUIREMENTS

TOP LAYER DESCRIPTION	DRILLED HOLE DIAMETER	COPPER THICKNESS	TIN-LEAD THICKNESS	NICKEL THICKNESS	GOLD THICKNESS	TIN THICKNESS	SILVER THICKNESS	FINISHED HOLE DIAMETER
TIN-LEAD	0.81-0.86 (0.85 DRILL)	0.025 - 0.050	0.005 - 0.015	--	--	--	--	0.65 - 0.80
IMMERSION TIN	0.81-0.86 (0.85 DRILL)	0.025 - 0.050	--	--	--	0.9 - 1.5um	--	0.70 - 0.80
IMMERSION SILVER	0.81-0.86 (0.85 DRILL)	0.025 - 0.050	--	--	--	--	0.15 - 0.65um	0.70 - 0.80
COPPER (SEE NOTE 9)	0.81-0.86 (0.85 DRILL)	0.025 - 0.050	--	--	--	--	--	0.70 - 0.80
GOLD	0.81-0.86 (0.85 DRILL)	0.025 - 0.050	--	0.003 - 0.007	FLASH UP TO 0.0002	--	--	0.69 - 0.80

TOP LAYER DESCRIPTION

TABLE 2 (HPC SIGNALS)
PLATED THROUGH-HOLE REQUIREMENTS

TOP LAYER DESCRIPTION	DRILLED HOLE DIAMETER	COPPER THICKNESS	TIN-LEAD THICKNESS	FINISHED HOLE DIAMETER
TIN-LEAD	1.125-1.175 ($\varnothing .0453 \pm .0010$)	0.025-0.050	0.005-0.015	0.94 - 1.10 ($\varnothing .040 \pm .003$)
IMMERSION TIN			--	
IMMERSION SILVER			--	
COPPER (SEE NOTE 9)			--	
GOLD			--	



Copyright FCI.

dr	NotFound DuWa	2010/04/27	projection	MM	size	A2	scale	4:1
eng	De-Ming Lu	2014/12/28			ecn no	ELX-DG-19849-1		
chr	-	-			rel level	Released		
appr	Pei-Ming Zheng	2014/12/29	product family	-	cat. no.	R/A HDR ASSY 4P+12S+4P		
www.fci.com			title			HCI POWER CONNECTOR		
			dwg no			10080655		
			rev			B		
			Product - Customer Drw			sheet 4 of 5		

PART NUMBER	RETENTION CLIPS	#4 SCREW	DIM A (TAIL LENGTH)	TAIL TYPE
10080655-001LF	NO	YES	3.43	SOLDER TAIL
10080655-002LF	NO	YES	4.70	SOLDER TAIL
10080655-003LF	YES	NO	3.43	SOLDER TAIL
10080655-004LF	YES	NO	4.70	SOLDER TAIL

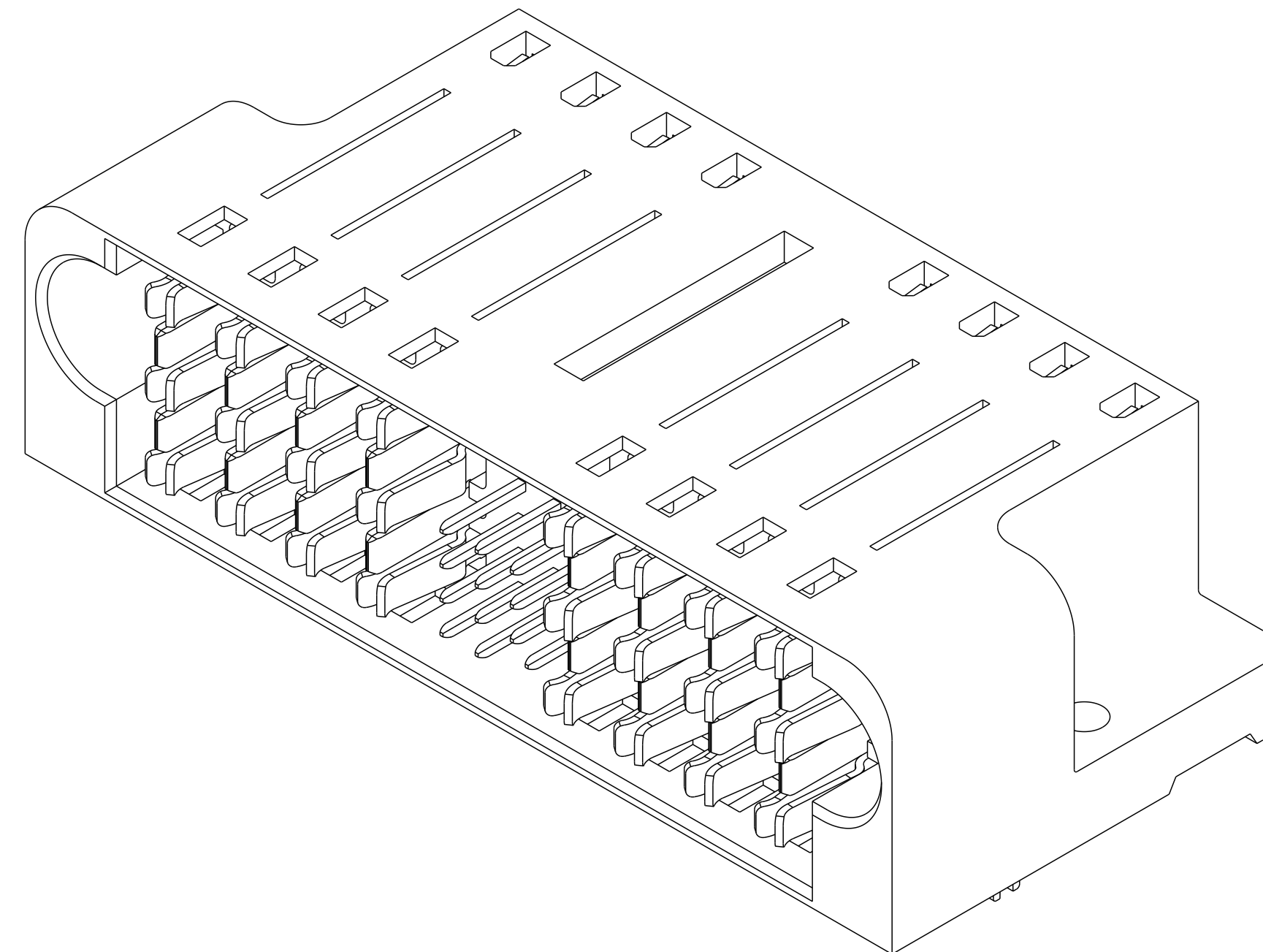

NOTES:

1. CONNECTOR MATERIALS:
HOUSING: HIGH TEMPERATURE THERMOPLASTIC, BLACK
UL 94V-0 COMPLIANT
CONTACTS: HIGH PERFORMANCE COPPER ALLOY
2. CONTACT FINISH (ref GS-12-380 SECTION 5.2)
3. PRODUCT SPECIFICATION: GS-12-380.
4. APPLICATION SPECIFICATION: GS-20-070.
5. PRODUCT MARKING (PRODUCT NUMBER & DATE CODE) ON HOUSING IN AREA SHOWN.
6. MINIMUM NOMINAL PCB THICKNESS: 1.6mm
7. PACKAGING MEETS FCI SPECIFICATION GS-14-1073.
8. HOUSING COMPONENT WILL WITHSTAND EXPOSURE TO 260°C PEAK TEMPERATURE FOR 60 SECONDS IN A CONVECTION, INFRA-RED, OR VAPOR PHASE REFLOW OVEN.
9. COPPER PLATING THICKNESS IN CENTER OF VIA-HOLE CAN BE NO MORE THAN 0.003 LESS THAN OTHER AREAS.
10. ALL HOLE SIZES ARE FINISHED HOLE SIZES.
11. MOUNTING HOLES ARE UNPLATED.

dr	Not Found DuWa	2010/04/27	projection	MM	size	A2	scale	3:1	
eng	De-Ming Lu	2014/12/28			ecn no	ELX-DG-19849-1			
chr	-	-			rel level	Released			
appr	Pei-Ming Zheng	2014/12/29	product family	HCI					
		title	R/A HDR ASSY 4P+12S+4P		dwg no	10080655		rev	B
www.fci.com		cat. no.	-		Product - Customer Drw		sheet 5 of 5		