

LOC	DIST	REVISIONS				
P	LTR	DESCRIPTION	DATE	DWN	APVD	
		NC	NEW RELEASE PER E.O. P15416	05SEP1997	SB	RDR
		A	REVISED PER E.O. P15904	12FEB1999	RO	RDR
		B	REVISED PER E.O. P17090	22JAN2001	AR	RDR
		C	REVISED PER ECO-14-019072	23FEB2015	JA	DM

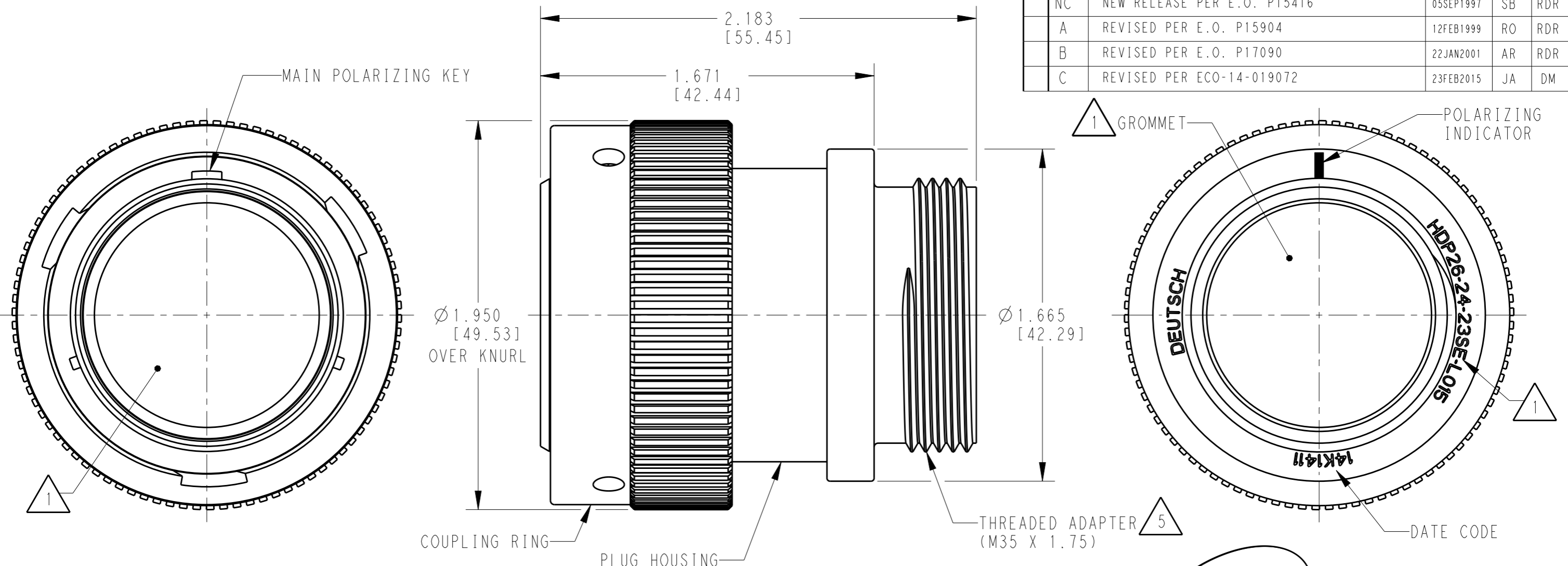

6. PART MODIFICATION: THREADED ADAPTER

5 CONDUIT ADAPTER ACCEPTS EITHER TYPES:  
 A. CONDUIT ADAPTER CAP NUT (CN21) AND SEAL RING (SRN21)  
 B. BACKSHELL (M902-2243), COMPRESSION NUT (M902-2053), CABLE Ø .430-.570 [10.92-14.78]  
 C. BACKSHELL (M902-2244), COMPRESSION NUT (M902-2054), CABLE Ø .570-710 [14.78-18.03]

4 MATERIAL: PLUG HOUSING/COUPLING RING: PA66 GF10 (BLACK)  
 CONDUIT ADAPTER: PA66 GF10 (GREEN, GRAY, BLUE)  
 GROMMET: SILICONE (ORANGE-RED)

3 SEE 0425-021-0000 APPLICATION SPECIFICATION  
 A. RECOMMENDED WIRE INSULATION RANGE  
 B. CONTACT REMOVAL TOOLS

2. THIS PLUG MATES WITH HDP24-24XXP/SX-XXXX RECEPTACLE  
 X = SEAL TYPE (N,T,E)  
 XX = INSERT ARRANGEMENT  
 XXXX = MODIFICATION

1 SEE CUSTOMER DRAWING 0425-014-2400 FOR AVAILABLE INSERT ARRANGEMENTS AND PART NUMBERS.

NOTES:

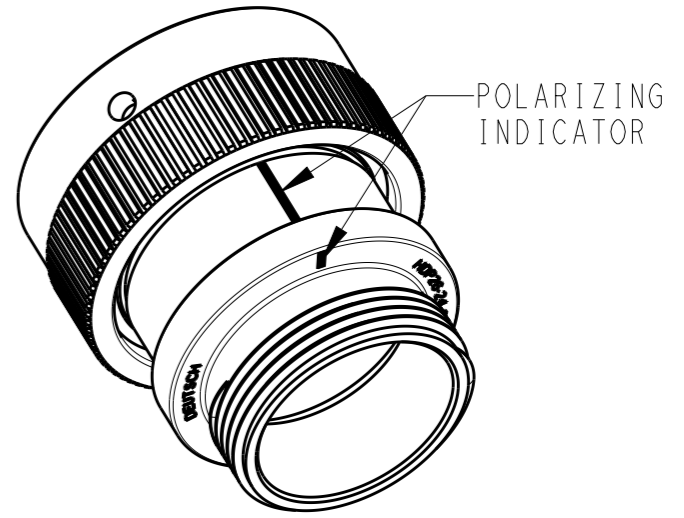

THIS DRAWING IS A CONTROLLED DOCUMENT.		DWN	19 JAN 1999	 TE Connectivity	NAME PLUG, COUPLING RING SIZE 24, -L015 MOD HDP SERIES
DIMENSIONS: INCHES [mm]		CHK	15 JAN 2001		
TOLERANCES UNLESS OTHERWISE SPECIFIED:		APVD	15 JAN 2001	PRODUCT SPEC 0425-021-0000	SIZE A3
0 PLC ± 1 PLC ± 2 PLC ± 3 PLC ±.015 [0.38] 4 PLC ± ANGLES ±0°30'0"		STEVE BEARD	STEVE BEARD		
MATERIAL	4	FINISH	N/A	WEIGHT	DRAWING NO HDP26-24-XXP/SX-L015
Customer Drawing		SCALE 2:1		SHEET 1 OF 1	
				REV C	