

THIS DRAWING IS UNPUBLISHED. RELEASED FOR PUBLICATION
 © COPYRIGHT - By - ALL RIGHTS RESERVED.

REVISIONS				
P	LTR	DESCRIPTION	DATE	APVD
G1		REVISED PER ECO-16-013568	21SEP2016	NK DR
G2		REVISED PER ECO-17-008806	20FEB2018	RS DR

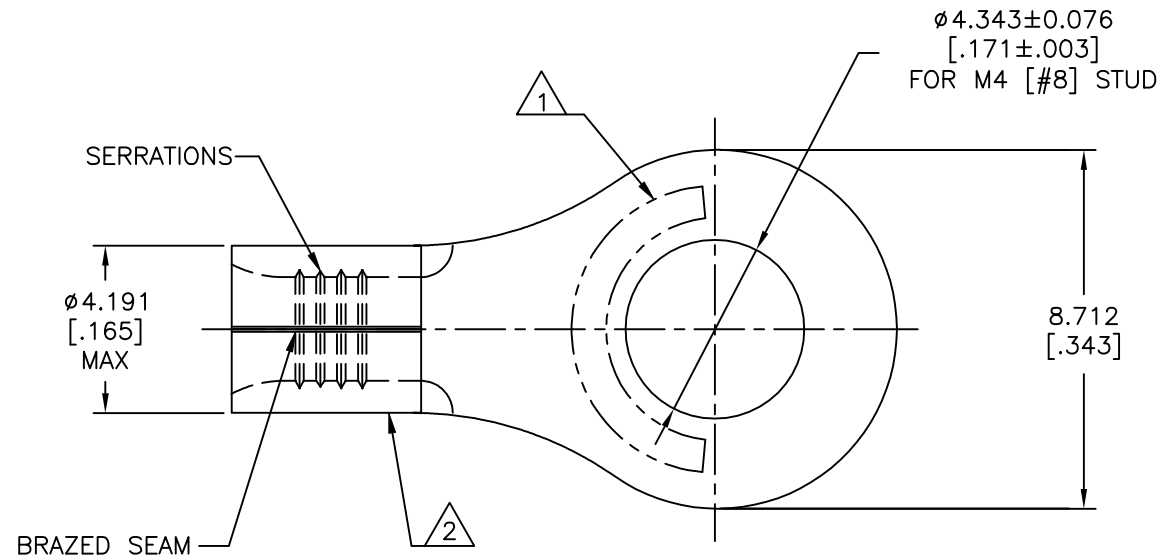

AMP WIRE RANGE	E13288 Listed
16-14 AWG SOLID OR STRANDED	NOT APPLICABLE
LR7189 Certified	MILITARY P/N AND CLASS
NOT APPLICABLE	NOT APPLICABLE

- STAMP AMP 16-14 APPROX AS SHOWN
- WIRE BARREL COLOR CODED ORANGE TO DENOTE NICKEL MATERIAL
- 3 NOTE DELETED

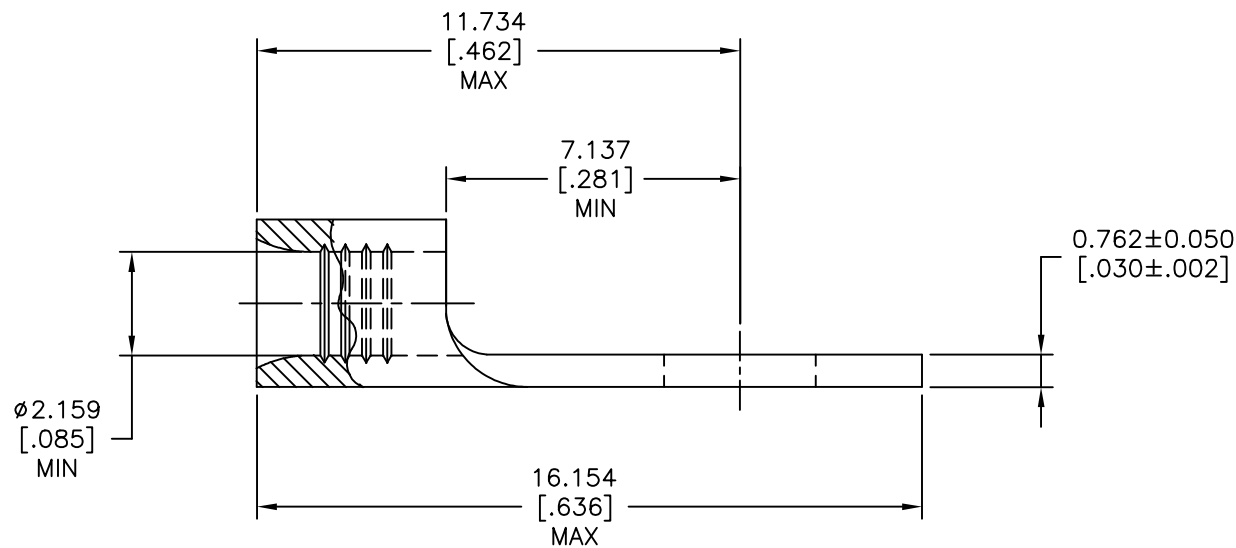

1000	LOOSE PIECE	322334
QTY.	PACKAGE TYPE	PART NUMBER

AMP INCORPORATED CUSTOMER SERVICE SYSTEMS	
FOR ADDITIONAL PRODUCT INFORMATION OR COPIES OF DRAWINGS AND TECHNICAL DOCUMENTS	PRODUCT INFORMATION CENTER 1-800-522-6752
FOR APPLICATION	TOOLING ASSISTANCE CENTER 1-800-722-1111
TOOLING INFORMATION	1-800-722-1111
FOR ORDER ENTRY	1-800-526-5142
MAX RECOMMENDED OPERATING TEMPERATURE: 649°C [1200°F] MAX	
VOLTAGE RATING: NOT APPLICABLE	
WIRE CROSS SECTIONAL AREA RANGE, 1.04-2.62mm ² [2,050-5,180] CIR MILS SOLID OR STRANDED	

THIS DRAWING IS A CONTROLLED DOCUMENT.	
DIMENSIONS: mm [INCHES]	TOLERANCES UNLESS OTHERWISE SPECIFIED:
	0 PLC \pm -
	1 PLC \pm -
	2 PLC \pm -
	3 PLC \pm .127 [.005]
	4 PLC \pm -
	ANGLES \pm -
MATERIAL:	FINISH:
NICKEL PER ASTM B-162 ANNEALED	-

DWN TA BRINKMAN 4-15-93	TE Connectivity Ltd.	
CHK DA PATTERSON 4-15-93	NAME	
APVD DE MILLER 4-15-93	TERMINAL, RING TONGUE, HIGH TEMPERATURE, STRATO-THERM 16-14 AWG	
PRODUCT SPEC	SIZE	CAGE CODE
APPLICATION SPEC	A2	00779
WEIGHT	DRAWING NO	DRAWING NO
-	C=322334	RESTRICTED TO
CUSTOMER DRAWING	SCALE	SHEET
	8:1	1 of 1
		REV G2