

PRODUCT NO.

SEE TABLE

10085176 - XXX

LF

LEAD FREE

PACKAGING OPTION NOTE 8, OMIT IF NOT REQUIRED.

NO. OF POSITIONS PER ROW

PLATING CODE

BASE PART NUMBER

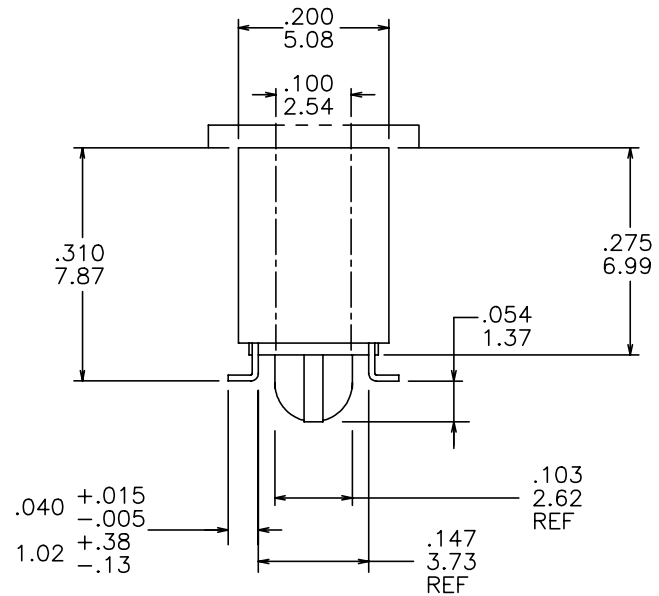
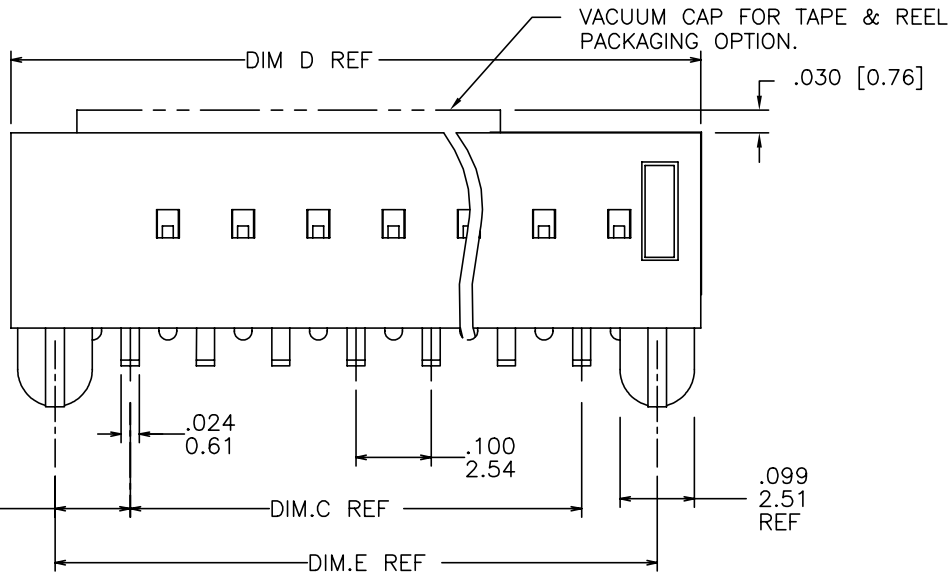
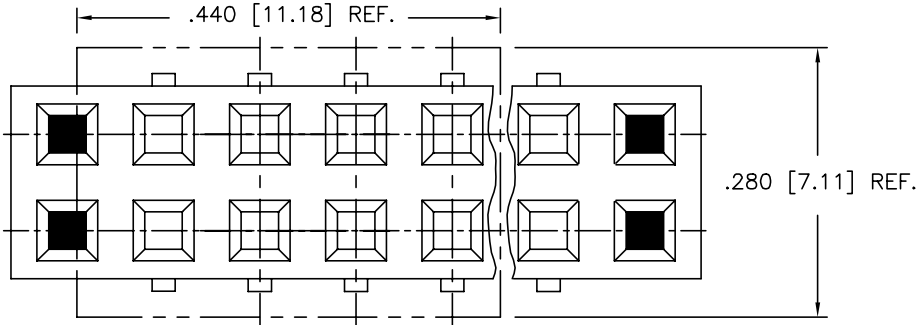

mat'l. code		surface		tolerance		projection		product family	
NOTES 1,3,8 & 12		ISO 1302 ✓		ISO 406		ISO 1101		DUBOX	
ltr	ecr	ndr	date	tolerances unless otherwise specified				title	
A	MO8-0072	MHT	2/17/07	XXX±.01/XXX±.03		INCH/MM		SMT DOUBLE ROW	
B	ELX-N-14890	ZK	06/03/13	XXX±.0005/XXX±0.13		scale 1:1		VCC ASSEMBLY	
				0°±2'		XXX±.0020/XXX±0.051		dwg no	
				dr	M.HERNANDEZ	2/17/07	sheet 1 of 6		
				enr	A.LUGO	2/17/07	size		
				chr	A.LUGO	2/17/07	10085176		
				app	A.LUGO	2/17/07	A3		
sheet		revision		B		B		type	
index	sheet	1	2	3	4	5	6	Product Customer Drawing	

PRODUCT NUMBER  
SEE TABLE

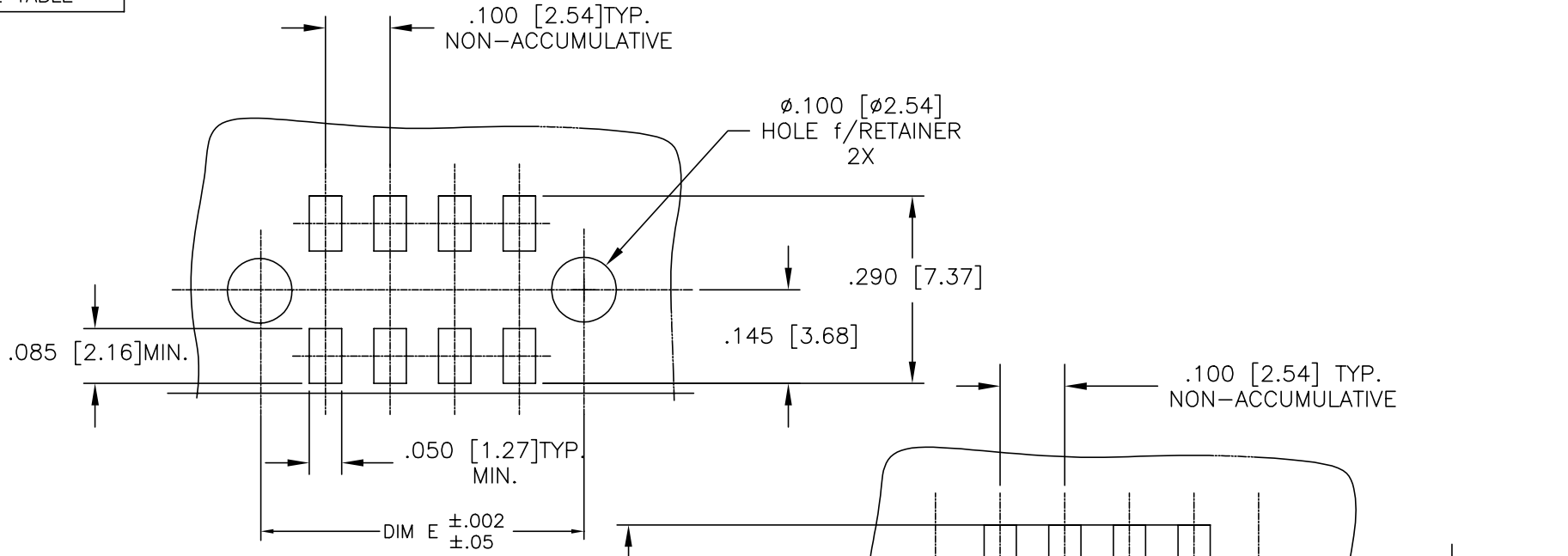

FIGURE A  
TOP ENTRY  
.025/.64 SQUARE PIN

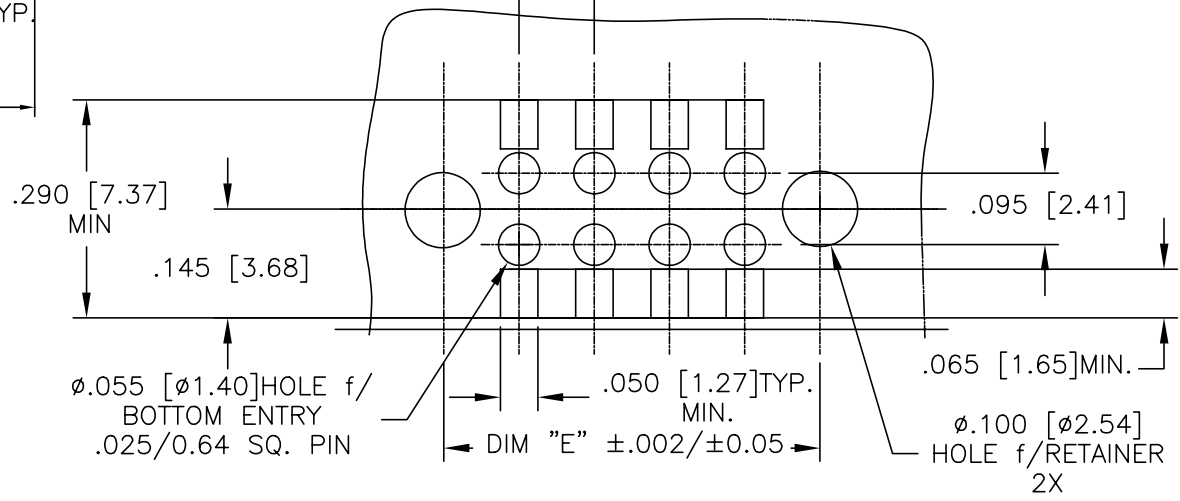

FIGURE B  
BOTTOM ENTRY (THROUGH PWB)  
.025/.64 SQUARE PIN

mat'l. code		surface		tolerance		projection		product family	
NOTES 1,3,8 & 12		ISO 1302 ✓		ISO 406		ASME Y14.5		DUBOX	
ltr ecn n°dr date		tolerances unless otherwise specified		INCH/MM		title			
B		linear		.001/.001		SMT DOUBLE ROW			
		0°±2'		.0005/.0005		VCC ASSEMBLY			
				.0005/.0005		scale 1:1		dwg no	
		dr		M.HERNANDEZ		2/17/07		sheet 2 of 6	
		engr		A.LUGO		2/17/07		size	
		chr		A.LUGO		2/17/07		10085176	
		appd		A.LUGO		2/17/07		A3	
sheet index		revision sheet						type Product Customer Drawing	

1

2 3

4

5

6

PRODUCT NO.

SEE TABLE

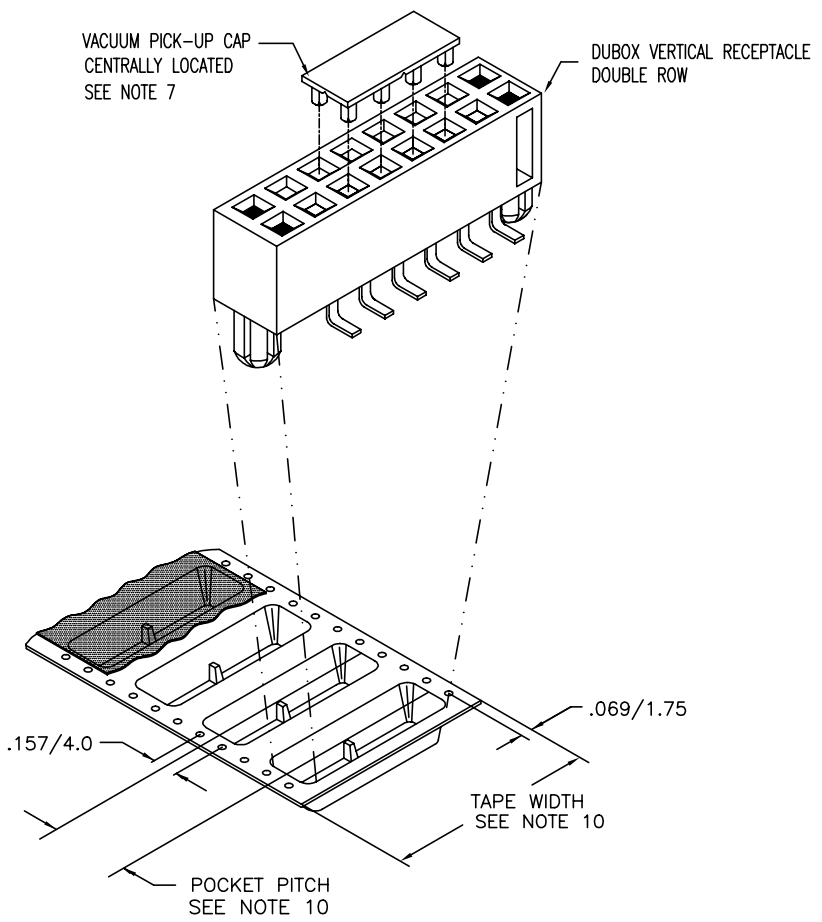

TAPE AND REEL PACKAGING ONLY

mat'l. code		surface		tolerance		projection		product family	
NOTES 1,3,8& 12		ISO 1302 ✓		ISO 406 ISO 1101				DUBOX	
ltr ecn n°dr date		tolerances unless otherwise specified		INCH/MM		title			
B		angles linear $.XXX \pm .01 / .XXX \pm .03$ $.XXX \pm .005 / .XXX \pm .013$ $.XXX \pm .0020 / .XXX \pm .0051$		scale 1:1		SMT DOUBLE ROW VCC ASSEMBLY			
		dr M.HERNANDEZ 2/17/07						dwg no sheet 3 of 6 size	
		enr A.LUGO 2/17/07				10085176		A3	
		chr A.LUGO 2/17/07				type Product Customer Drawing			
		app A.LUGO 2/17/07							
sheet index		revision sheet							



Copyright FCI

PRODUCT NO NOTE 11	PLATING CONTACT AREA	PLATING SOLDER TAIL	MATERIAL REF
10085176-2XXLF	15u"/.38u Au MIN OVER 50u"/1.27u Ni MIN SEE NOTE 14	100u"/160u" 2.54u/4.06u	NOTE 3 & 4
10085176-3XXLF	30u"/.76u Au MIN OVER 50u"/1.27u Ni MIN SEE NOTE 14	100u"/160u" 2.54u/4.06u	NOTE 3 & 4
10085176-6XXLF	30u"/.76u Au MIN OVER 50u"/1.27u Ni MIN SEE NOTE 14	100u"/160u" 2.54u/4.06u	NOTE 3 & 4

NOTES:

- ①. MATERIAL TERMINAL: PHOSPHOR BRONZE,
2. RECOMMENDED APPLICATION DATA:
  - A. RECOMMENDED SOLDER PAD PATTERN IS SHOWN IN FIGURE A & B.
  - B. ALL MATING PINS TO BE .025/.64. SQUARE ON TRUE CENTER OF GIVEN TERMINAL SPACING WITHIN .015/.38. DIA.
  - C. SUGGESTED MATING PIN LENGTH .210 ±.020/5.33 ±.51.
- ③. MATERIAL HOUSING: P.P.S. FILLED,COLOR BLACK  
FLAME RETARDANT PER UL 94V-0.  
COMPATIBLE WITH INFRA-RED SOLDERING.  
THIS PART WILL WITHSTAND EXPOSURES TO 260°C  
PEAK TEMPERATURE FOR 20 SECONDS IN WAVE SOLDER,  
INFRA-RED OR VAPOR PHASE SOLDER PROCESS.
- ④. PRESTAMPED POST PLATED TERMINALS.
5. FCI, FCI FINAL PART NUMBER AND DATE CODE TO BE MARKED ON TUBE LABEL.
6. CARRIER TAPE WIDTH 24 MIN. & BELOW TO HAVE PILOT HOLES ON ONE SIDE OF TAPE ONLY. SIZES ABOVE 24mm TO HAVE PILOT HOLES ON BOTH SIDES OF TAPE.
- ⑦. VACUUM CAP MATERIAL FOR TAPE & REEL PACKAGING:  
L.C.P., FLAME RETARDANT PER UL 94V-0.  
COLOR: BLACK
- ⑧. ADD SUFFIX "P" TO PART DASH NUMBER FOR TAPE AND REEL PACKAGING.  
EXAMPLE: 10085176-XXXXP
9. MAXIMUM LENGTH OF CONNECTOR FOR TAPE AND REEL PACKAGING IS 2.50 INCHES LONG/63.5 MM.
- ⑩. TAPE & REEL PACKAGING 72mm WIDE TAPE WITH 16mm POCKET PITCH.
- ⑪. PART NUMBER WITH "LF" SUFFIX AT THE END ARE LEAD FREE.
12. THESE PRODUCTS MEETS EUROPEAN UNION DIRECTIVES AND OTHER COUNTRY REGULATION AS DESCRIBED IN GS-22-008.
- ⑬. "THIS PRODUCT HAS 100%% TIN PLATING IN THE INTERFACE AND HAS NOT BEEN TESTED FOR WHISKER GROWTH IN ALL INTERCONNECT ENVIRONMENTS."
- ⑭. PLATING OPTIONS:  
MAY BE EITHER GOLD OR GXT PLATED AT MANUFACTURER'S OPTION.

FCI  
FCIconnect.com

Copyright FCI

mat'l code NOTES 1,3,8 & 12		surface ISO 1302 ✓	tolerance ISO 406 ISO 1101	projection 	product family DUBOX
l	tr	ec	n	o	dr
date		tolerances unless otherwise specified		title	
B		angles	line	INCH/MM	SMT DOUBLE ROW VCC ASSEMBLY
		0°±2'	XXX±.01/XXX.3 XXX±.0005/XXX.13 XXX±.0020/XXX.05	scale 1:1	
		dr	M.HERNANDEZ	2/17/07	dwg no
		engr	A.LUGO	2/17/07	sheet 4 of 6
		chr	A.LUGO	2/17/07	size
		appd	A.LUGO	2/17/07	A3
sheet		revisi		type	
index	sheet			Product Customer Drawing	

PRODUCT NO	NO OF POS	DIM C	DIM D	DIM E	TAPE & REEL PACKAGING	LEAD FREE
10085176-Y02LF	2 X 2	.100/2.54	.417/10.59	.300/7.62	NO	
10085176-Y03LF	2 X 3	.200/5.08	.517/13.13	.400/10.16	NO	
10085176-Y04LF	2 X 4	.300/7.62	.617/15.67	.500/12.70	NO	
10085176-Y05LF	2 X 5	.400/10.16	.717/18.21	.600/15.24	NO	
10085176-Y06LF	2 X 6	.500/12.70	.817/20.75	.700/17.78	NO	
10085176-Y07LF	2 X 7	.600/15.24	.917/23.29	.800/20.32	NO	
10085176-Y08LF	2 X 8	.700/17.78	1.017/25.83	.900/22.86	NO	
10085176-Y09LF	2 X 9	.800/20.32	1.117/28.37	1.000/25.40	NO	
10085176-Y10LF	2 X 10	.900/22.86	1.217/30.91	1.100/27.94	NO	
10085176-Y11LF	2 X 11	1.000/25.40	1.317/33.45	1.200/30.48	NO	
10085176-Y12LF	2 X 12	1.100/27.94	1.417/35.99	1.300/33.02	NO	
10085176-Y13LF	2 X 13	1.200/30.48	1.517/38.53	1.400/35.56	NO	
10085176-Y14LF	2 X 14	1.300/33.02	1.617/41.07	1.500/38.10	NO	
10085176-Y15LF	2 X 15	1.400/35.56	1.717/43.61	1.600/40.64	NO	
10085176-Y16LF	2 X 16	1.500/38.10	1.817/46.15	1.700/43.18	NO	
10085176-Y17LF	2 X 17	1.600/40.64	1.917/48.69	1.800/45.72	NO	
10085176-Y18LF	2 X 18	1.700/43.18	2.017/51.23	1.900/48.26	NO	
10085176-Y19LF	2 X 19	1.800/45.72	2.117/53.77	2.000/50.80	NO	
10085176-Y20LF	2 X 20	1.900/48.26	2.217/56.31	2.100/53.34	NO	
10085176-Y20PLF	2 X 20	1.900/48.26	2.217/56.31	2.100/53.34	YES - NOTE 8 & 10	
10085176-Y21LF	2 X 21	2.000/50.80	2.317/58.85	2.200/55.08	NO	
10085176-Y22LF	2 X 22	2.100/53.34	2.417/61.39	2.300/58.42	NO	
10085176-Y23LF	2 X 23	2.200/55.88	2.517/63.93	2.400/60.96	NO	
10085176-Y24LF	2 X 24	2.300/58.42	2.617/66.47	2.500/63.50	NO	
10085176-Y25LF	2 X 25	2.400/60.96	2.717/69.01	2.000/66.04	NO	

NOTE 11

mat'l. code	surface	tolerance	projection	product family
NOTES 1,3,8 & 12	ISO 1302 ✓	ISO 406 ISO 1101		DUBOX
ltr ecn nldr date	tolerances unless otherwise specified			title
B	angles	linear	INCH/MM	SMT DOUBLE ROW VCC ASSEMBLY
	0°±2'		scale 1:1	dwg no
	dr	M.HERNANDEZ	2/17/07	sheet 5 of 6
	enr	A.LUGO	2/17/07	size
	chr	A.LUGO	2/17/07	10085176
	app	A.LUGO	2/17/07	A3
sheet index	revision sheet			type Product Customer Drawing



Copyright FCI

PRODUCT NO	NO OF POS	DIM C	DIM D	DIM E	TAPE & REEL PACKAGING	LEAD FREE
10085176-Y26LF	2 X 26	2.500/63.50	2.817/71.55	2.700/68.58	NO	
10085176-Y27LF	2 X 27	2.600/66.04	2.917/74.09	2.800/71.12	NO	
10085176-Y28LF	2 X 28	2.700/68.58	3.017/76.63	2.900/73.66	NO	
10085176-Y29LF	2 X 29	2.800/71.12	3.117/79.17	3.000/76.20	NO	
10085176-Y30LF	2 X 30	2.900/73.66	3.217/81.71	3.100/78.74	NO	
10085176-Y31LF	2 X 31	3.000/76.20	3.317/84.25	3.200/81.28	NO	
10085176-Y32LF	2 X 32	3.100/78.74	3.417/86.79	3.300/83.32	NO	
10085176-Y33LF	2 X 33	3.200/81.28	3.517/89.33	3.400/86.36	NO	
10085176-Y34LF	2 X 34	3.300/83.32	3.617/91.87	3.500/88.90	NO	
10085176-Y35LF	2 X 35	3.400/86.36	3.717/94.41	3.600/91.44	NO	
10085176-Y36LF	2 X 36	3.500/88.90	3.817/96.95	3.700/93.98	NO	
10085176-Y37LF	2 X 37	3.600/91.44	3.917/99.49	3.800/96.52	NO	
10085176-Y38LF	2 X 38	3.700/93.98	4.017/102.03	3.900/99.06	NO	
10085176-Y39LF	2 X 39	3.800/96.52	4.117/104.57	4.000/101.60	NO	
10085176-Y40LF	2 X 40	3.900/99.06	4.217/107.11	4.100/104.14	NO	
10085176-Y41LF	2 X 41	4.000/101.60	4.317/109.65	4.200/106.68	NO	
10085176-Y42LF	2 X 42	4.100/104.14	4.417/112.19	4.300/109.22	NO	
10085176-Y43LF	2 X 43	4.200/106.68	4.517/114.73	4.400/111.76	NO	
10085176-Y44LF	2 X 44	4.300/109.22	4.617/117.27	4.500/114.30	NO	
10085176-Y45LF	2 X 45	4.400/111.76	4.717/119.81	4.600/116.84	NO	
10085176-Y46LF	2 X 46	4.500/114.30	4.817/122.35	4.700/119.38	NO	
10085176-Y47LF	2 X 47	4.600/116.84	4.917/124.89	4.800/121.92	NO	
10085176-Y48LF	2 X 48	4.700/119.38	5.017/127.43	4.900/124.46	NO	
10085176-Y49LF	2 X 49	4.800/121.92	5.117/129.97	5.000/127.00	NO	
10085176-Y50LF	2 X 50	4.900/124.46	5.217/132.51	5.100/129.54	NO	
10085176-Y16PLF	2 X 16	1.500/38.10	1.817/46.15	1.700/43.18	YES - NOTE 8 & 10	

NOTE 11

mat'l. code	surface	tolerance	projection	product family
NOTES 1,3,8 & 12	ISO 1302 ✓	ISO 406 ISO 1101		DUBOX
ltr ecn nldr date	tolerances unless otherwise specified		INCH/MM	title
B	angles	linear	scale 1:1	SMT DOUBLE ROW VCC ASSEMBLY
	0°±2'			dwg no 10085176 sheet 6 of 6 size A3
	dr M.HERNANDEZ	2/17/07		type Product Customer Drawing
	enr A.LUGO	2/17/07		
	chr A.LUGO	2/17/07		
	app A.LUGO	2/17/07		
sheet index	revision sheet			