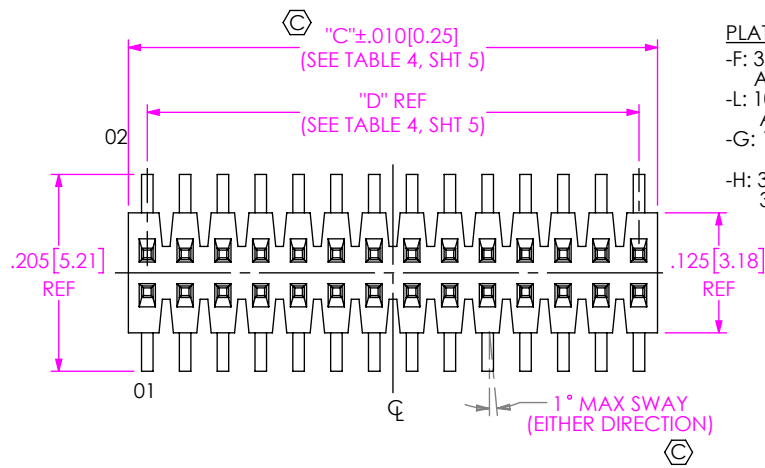

TABLE 1

"A" RANGE	BODY STYLE (SEE NOTE 5 & 6)		FIG
	UPPER	LOWER	
.095[2.41] - .129[3.28]	FTM-XX-D	FTM-XX-D	2
.130[3.30] - .245[6.22]	FTMH-XX-D	MW-XX-D	1

DO NOT SCALE FROM THIS PRINT

MW-XX-03-X-D-XXX-XXX-XX-X-XX



PLATING SPECIFICATION

- F: 3μ" SELECTIVE GOLD IN CONTACT AREA, MATTE TIN ON TAIL
- L: 10μ" SELECTIVE GOLD IN CONTACT AREA, MATTE TIN ON TAIL
- G: 10μ" GOLD IN CONTACT AREA, 3μ" GOLD ON TAIL
- H: 30μ" GOLD IN CONTACT AREA, 3μ" GOLD ON TAIL

ROW SPECIFICATION

- D: DOUBLE (SEE TABLE 1 FOR BODY)

BOARD SPACE OPTION

"A": .245 [6.22] MAX w/ .065 [1.65] POST, .095 [2.41] MIN.

- PACKAGING
- BLANK: TUBES (SEE NOTE 5)
  - TR: TAPE & REEL (SEE NOTES 11 & 12)
  - FR: FULL REEL QTY TAPE & REEL (SEE NOTES 11 & 12)
  - (-XR OPTION AVAILABLE FOR MAX HEIGHT: .6875)

- PICK AND PLACE OPTION
- P: PICK & PLACE PAD (SEE SHT 2, FIG 3, USE PPP-30) (7 POS PER ROW MIN) (USE PPP-30-NT FOR -TR ONLY)

- OPTION
- ES: END SHROUDS (9 POS PER ROW MIN) (SEE SHT 2, FIG 4) (MAX POST: .075 [1.91]) (SEE NOTE 8)
  - EP: GUIDE POST (9 POS PER ROW MIN) (SEE SHT 2, FIG 5) (MAX POST: .075 [1.91]) (SEE NOTE 8)
  - A: ALIGNMENT PINS (MOLDED OR STAKED, SAMTEC'S DISCRETION ON WHICH) (SEE FIGS 6 & 7, SHT 3) (STAKED: 7 POS MIN, 60 POS MAX) (MOLDED: 5 POS MIN, 75 POS MAX) (SEE NOTE 8)

POST HEIGHT  
.065 [1.65] MIN  
(POST + BOARD SPACE = .310 [7.87] MAX)

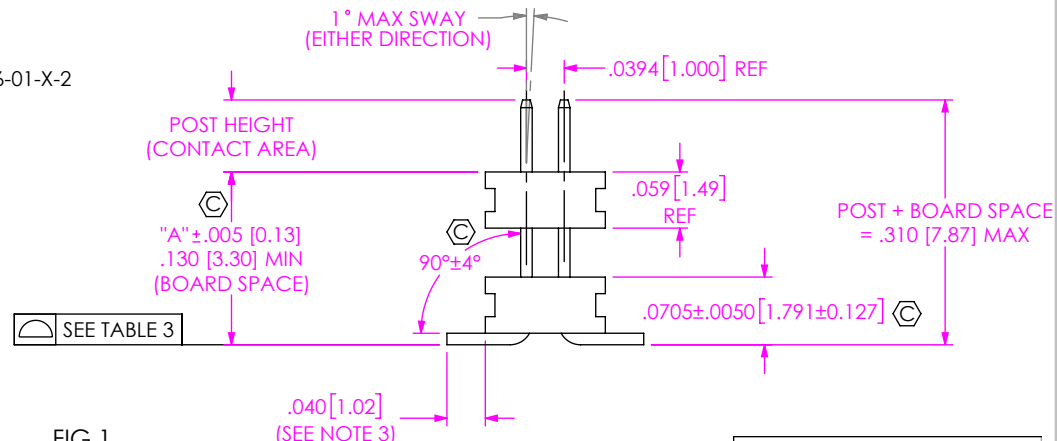
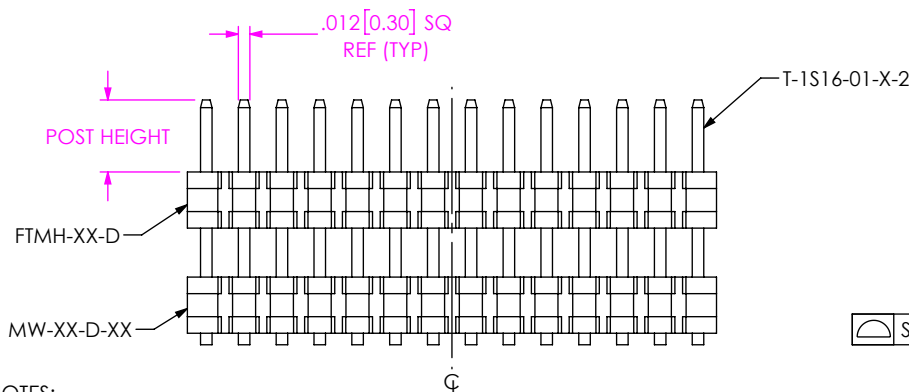

FIG 1  
MW-14-03-X-D-180-075 SHOWN

NOTES:

1. (C) REPRESENTS A CRITICAL DIMENSION.
2. PARTS MAY BE CUT TO POSITION; MAXIMUM CUT FLASH: .010[.25].
3. SHEAR TAILS TO DIMENSION SHOWN; BURR ALLOWANCE: .003[.038] MAX. (FOR HAND TOOLING ONLY)
4. PACKAGE POSITIONS 05 THROUGH 50 IN TUBES; LAYER PACKAGE POSITIONS 02 THROUGH 04.
5. HAND ASSEMBLED PARTS TO BE 2 BLACK BODIES AND MACHINE ASSEMBLED TO BE TOP:BLACK; BOTTOM: NATURAL, BOARD SPACE .130-245. BOARD SPACE .095-.129 WILL HAVE BLACK FTM BODY
6. FOR HAND FILL, USE FTMH-XX-D FOR LOWER BODY.
7. FOR MACHINE FILLED, USE T-1S16-03-X-2.
8. AVAILABLE ONLY WITH BOARD SPACE .130 TO .245.
9. 75 POSITION AVAILABLE FOR SAMTEC INVENTORY ONLY.
10. FOR ADDED MECHANICAL STABILITY, SAMTEC RECOMMENDS MECHANICAL BOARD SPACERS BE USED IN APPLICATIONS WITH GOLD OR SELECTIVE GOLD PLATED CONNECTORS. CONTACT IPG@SAMTEC.COM FOR MORE INFORMATION.
11. ORDERS WILL BE PACKAGED ACCORDING TO THE SAMTEC PACKAGING EFFICIENCY STANDARDS (SPES) FOUND ON WWW.SAMTEC.COM.
12. ATTACH LABEL TO EACH REEL.

TABLE 3	
No. OF POS	"A"
02-30 POS	.004 [0.10]
31-50 POS	.006 [0.15]

UNLESS OTHERWISE SPECIFIED, DIMENSIONS ARE IN INCHES.  
TOLERANCES ARE:  
DECIMALS ANGLES  
.XX: ±.01 [0.3] 2°  
.XXX: ±.005 [0.13]  
.XXXX: ±.0020 [0.051]

PROPRIETARY NOTE  
THIS DOCUMENT CONTAINS CONFIDENTIAL AND PROPRIETARY INFORMATION AND ALL DESIGN, MANUFACTURING, REPRODUCTION, USE, PATENT RIGHTS AND SALES RIGHTS ARE EXPRESSLY RESERVED BY SAMTEC, INC. THIS DOCUMENT SHALL NOT BE DISCLOSED, IN WHOLE OR PART, TO ANY UNAUTHORIZED PERSON OR ENTITY NOR REPRODUCED, TRANSFERRED OR INCORPORATED IN ANY OTHER PROJECT IN ANY MANNER WITHOUT THE EXPRESS WRITTEN CONSENT OF SAMTEC, INC.



520 PARK EAST BLVD, NEW ALBANY, IN 47150  
PHONE: 812-944-6733 FAX: 812-948-5047  
e-Mail: info@SAMTEC.com code 55322

MATERIAL: DO NOT SCALE DRAWING SHEET SCALE: 5:1  
INSULATOR: LCP; FTM-XX-D & FTMH-XX-D COLOR: BLACK  
MW-XX-D-XX COLOR: NATURAL  
TERMINAL: PHOS BRONZE  
MAX FLASH ALLOWED: .002[0.05]  
MAX GATE VESTIGE: .002[0.05]

DESCRIPTION:  
1mm x 1mm SM BOARD STACKER ASSEMBLY  
DWG. NO.  
MW-XX-03-X-D-XXX-XXX-XX-X-XX  
BY: BRATCHER 4/3/1995 SHEET 1 OF 5

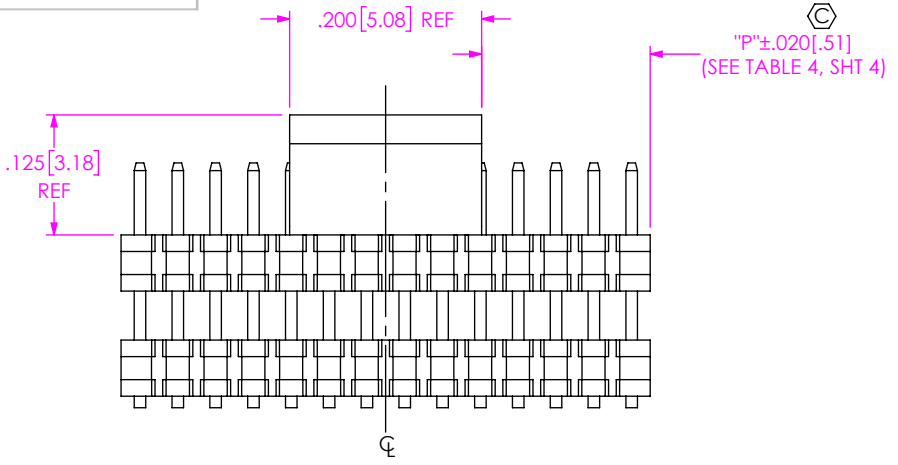

**FIG 3**  
MW-14-03-X-D-180-075-P SHOWN  
(DIFFERENT AS SHOWN, OTHERWISE SAME AS FIG 1)

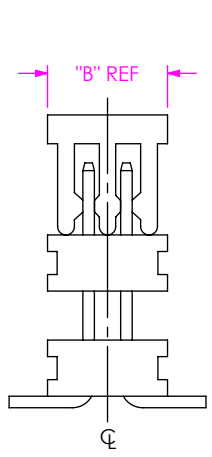
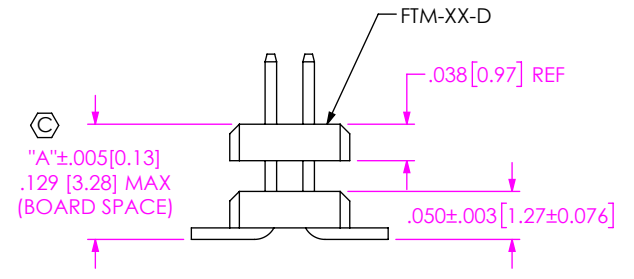
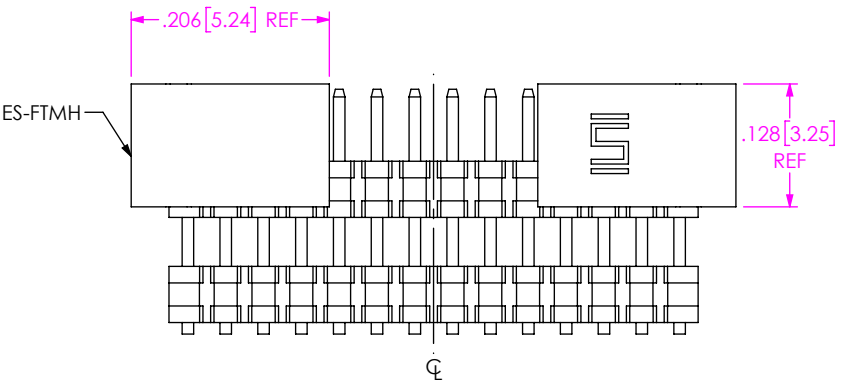
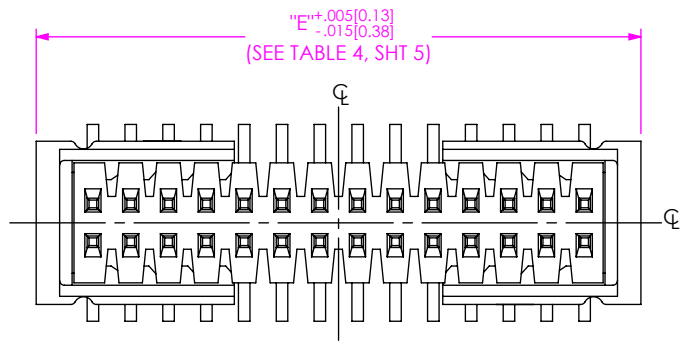

TABLE 2	
PART NO	"B"
PPP-30	.125 [3.18]
PPP-30-NT	.190 [4.83]



**FIG 2**  
MW-10-03-X-D-120-073 SHOWN  
(DIFFERENT AS SHOWN, OTHERWISE SAME AS FIG 1)



**FIG 4**  
MW-14-03-X-D-180-075-ES SHOWN  
(DIFFERENT AS SHOWN, OTHERWISE SAME AS FIG 1)

**PROPRIETARY NOTE**  
THIS DOCUMENT CONTAINS CONFIDENTIAL AND PROPRIETARY INFORMATION AND ALL DESIGN, MANUFACTURING, REPRODUCTION, USE, PATENT RIGHTS AND SALES RIGHTS ARE EXPRESSLY RESERVED BY SAMTEC, INC. THIS DOCUMENT SHALL NOT BE DISCLOSED, IN WHOLE OR PART, TO ANY UNAUTHORIZED PERSON OR ENTITY NOR REPRODUCED, TRANSFERRED OR INCORPORATED IN ANY OTHER PROJECT IN ANY MANNER WITHOUT THE EXPRESS WRITTEN CONSENT OF SAMTEC, INC.

DO NOT SCALE DRAWING  
SHEET SCALE: 5:1



DESCRIPTION:  
1mm x 1mm SM BOARD STACKER ASSEMBLY

DWG. NO.  
MW-XX-03-X-D-XXX-XXX-XX-X-XX

BY: BRATCHER 4/3/1995 SHEET 2 OF 5

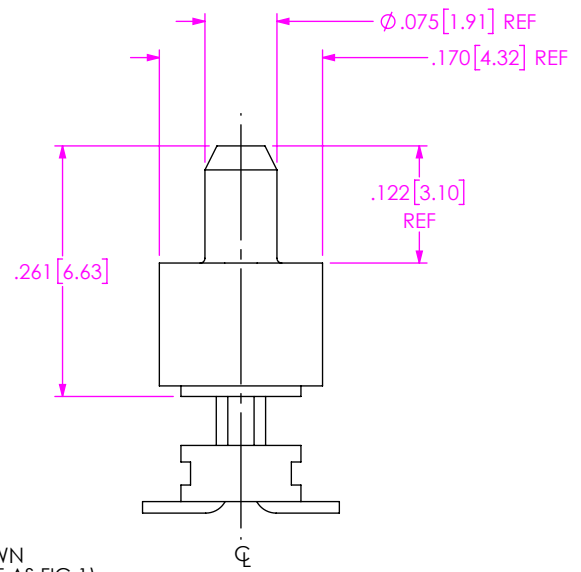
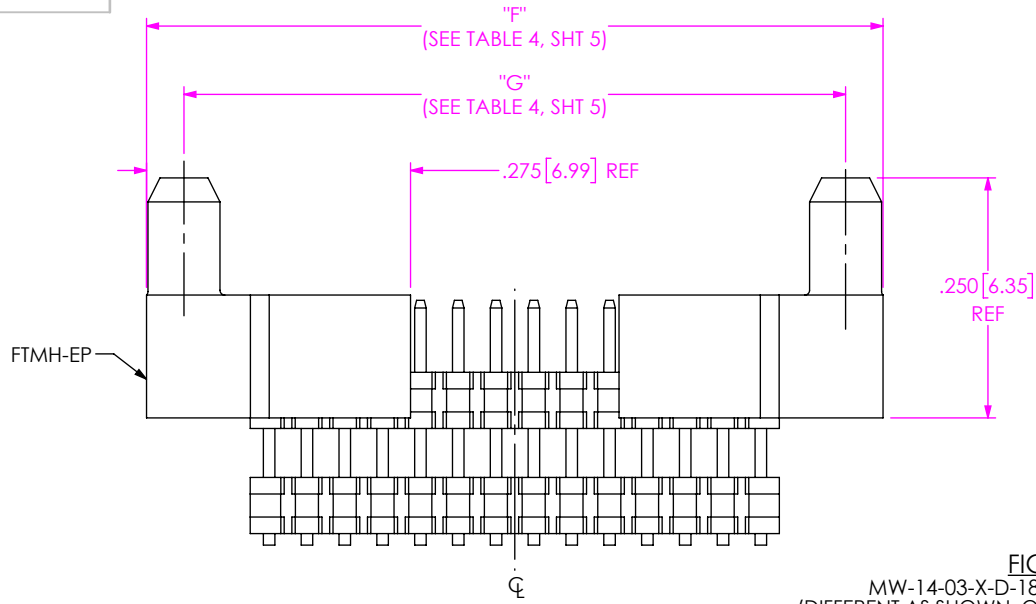

FIG 5  
MW-14-03-X-D-180-075-EP SHOWN  
(DIFFERENT AS SHOWN, OTHERWISE SAME AS FIG 1)

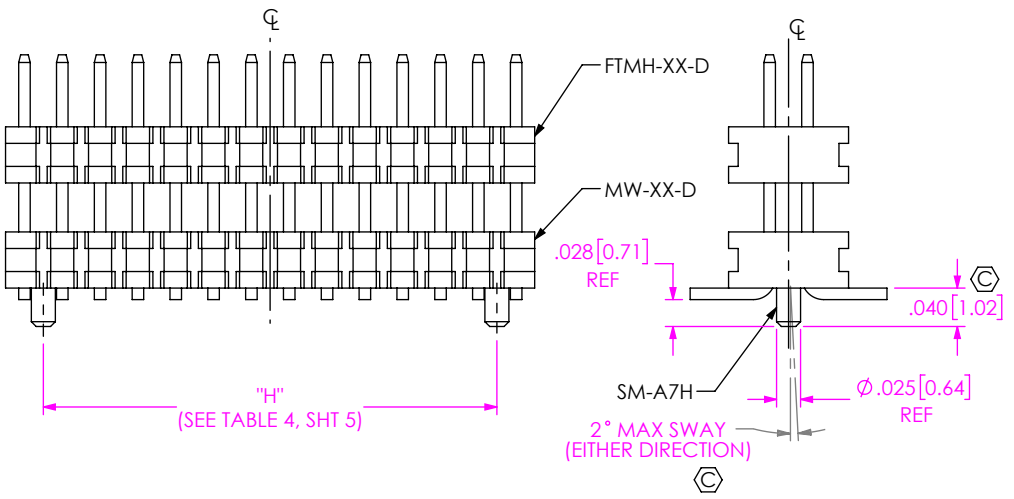

FIG 6  
STAKED -A OPTION  
MW-14-03-X-D-180-075-A SHOWN  
(60 POSITION MAX)  
(DIFFERENT AS SHOWN, OTHERWISE SAME AS FIG 1)

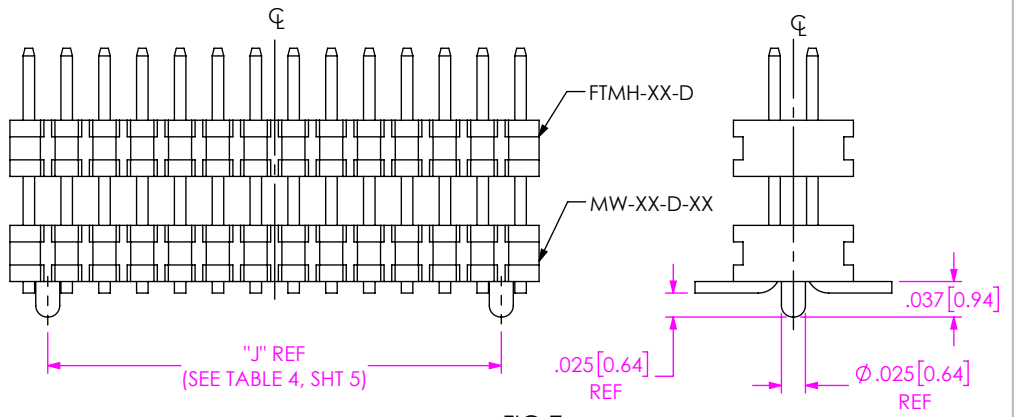

FIG 7  
MOLDED -A OPTION  
MW-14-03-X-D-180-075-A SHOWN  
(75 POSITION MAX)  
(DIFFERENT AS SHOWN, OTHERWISE SAME AS FIG 1)

**PROPRIETARY NOTE**  
THIS DOCUMENT CONTAINS CONFIDENTIAL AND PROPRIETARY INFORMATION AND ALL DESIGN, MANUFACTURING, REPRODUCTION, USE, PATENT RIGHTS AND SALES RIGHTS ARE EXPRESSLY RESERVED BY SAMTEC, INC. THIS DOCUMENT SHALL NOT BE DISCLOSED, IN WHOLE OR IN PART, TO ANY UNAUTHORIZED PERSON OR ENTITY NOR REPRODUCED, TRANSFERRED OR INCORPORATED IN ANY OTHER PROJECT IN ANY MANNER WITHOUT THE EXPRESS WRITTEN CONSENT OF SAMTEC, INC.

DO NOT SCALE DRAWING

SHEET SCALE: 5:1

**samtec**  
520 PARK EAST BLVD. NEW ALBANY, IN 47150  
PHONE: 812-944-6733 FAX: 812-948-5047  
e-Mail info@SAMTEC.com code 55322

DESCRIPTION:  
1mm x 1mm SM BOARD STACKER ASSEMBLY

DWG. NO.  
MW-XX-03-X-D-XXX-XXX-XX-X-XX

BY: BRATCHER 4/3/1995 SHEET 3 OF 5

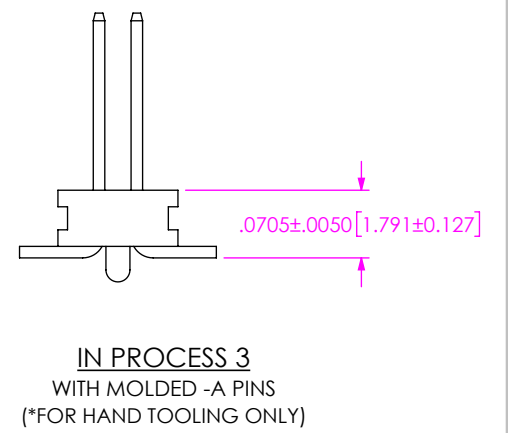
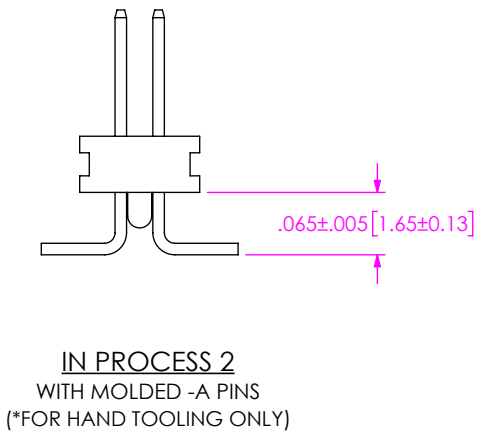
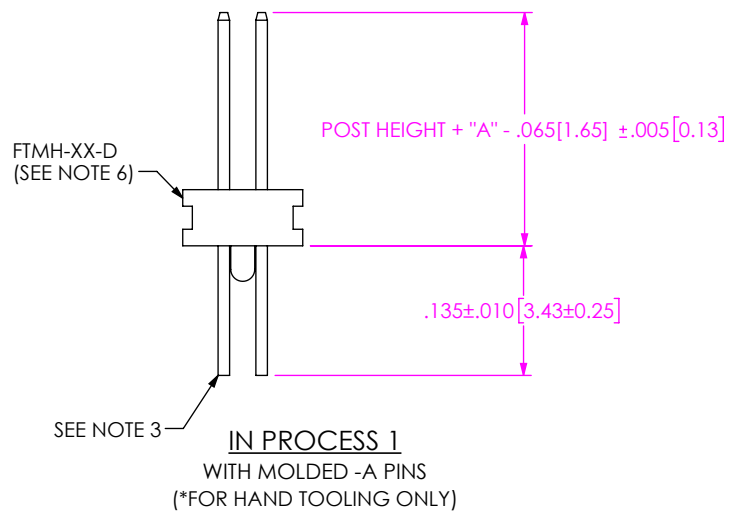
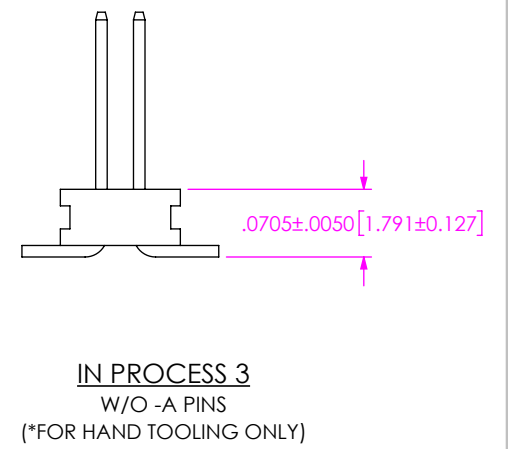
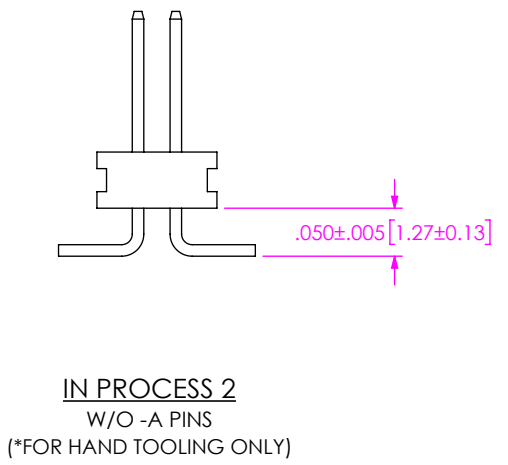
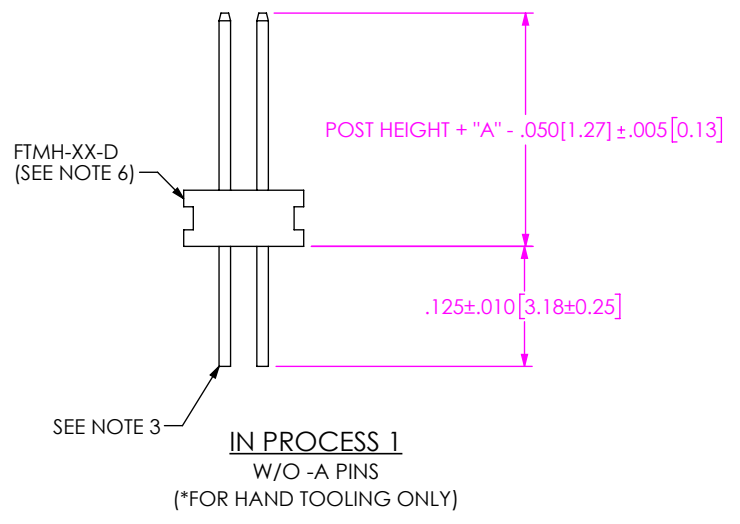

**PROPRIETARY NOTE**  
THIS DOCUMENT CONTAINS CONFIDENTIAL AND PROPRIETARY INFORMATION AND ALL DESIGN, MANUFACTURING, REPRODUCTION, USE, PATENT RIGHTS AND SALES RIGHTS ARE EXPRESSLY RESERVED BY SAMTEC, INC. THIS DOCUMENT SHALL NOT BE DISCLOSED, IN WHOLE OR PART, TO ANY UNAUTHORIZED PERSON OR ENTITY NOR REPRODUCED, TRANSFERRED OR INCORPORATED IN ANY OTHER PROJECT IN ANY MANNER WITHOUT THE EXPRESS WRITTEN CONSENT OF SAMTEC, INC.

**samtec**  
520 PARK EAST BLVD, NEW ALBANY, IN 47150  
PHONE: 812-944-6733 FAX: 812-948-5047  
e-Mail: info@SAMTEC.com code 55322

DO NOT SCALE DRAWING  
SHEET SCALE: 8:1

DESCRIPTION:  
1mm x 1mm SM BOARD STACKER ASSEMBLY  
DWG. NO.  
MW-XX-03-X-D-XXX-XXX-XX-X-XX  
BY: BRATCHER 4/3/1995 SHEET 4 OF 5

PT-1-24-02-60  
TP-03

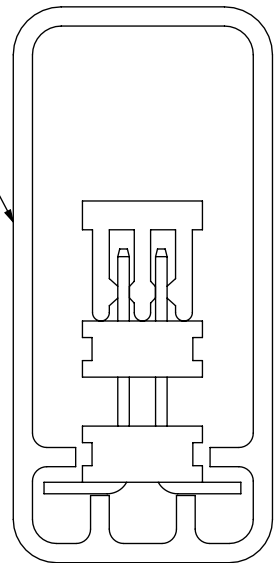

PACKAGING VIEW

TABLE 4

No. OF POS	"C"	"D"	"E"	"F"	"G"	"H"	"J"	"P"
02	.079 [2.00]	.039 [1.00]	N/A	N/A	N/A	N/A	N/A	N/A
03	.118 [3.00]	.079 [2.00]	N/A	N/A	N/A	N/A	N/A	N/A
04	.157 [4.00]	.118 [3.00]	N/A	N/A	N/A	N/A	N/A	N/A
05	.197 [5.00]	.157 [4.00]	N/A	N/A	N/A	N/A	.118 [3.00]	N/A
06	.236 [6.00]	.197 [5.00]	N/A	N/A	N/A	N/A	.157 [4.00]	N/A
07	.276 [7.00]	.236 [6.00]	N/A	N/A	N/A	.197 [5.00]	.197 [5.00]	.038 [0.96]
08	.315 [8.00]	.276 [7.00]	N/A	N/A	N/A	.236 [6.00]	.236 [6.00]	.057 [1.46]
09	.354 [9.00]	.315 [8.00]	.433 [11.00]	.570 [14.48]	.491 [12.47]	.276 [7.00]	.276 [7.00]	.077 [1.96]
10	.394 [10.00]	.354 [9.00]	.472 [12.00]	.609 [15.48]	.530 [13.47]	.315 [8.00]	.315 [8.00]	.097 [2.46]
11	.433 [11.00]	.394 [10.00]	.512 [13.00]	.649 [16.48]	.570 [14.47]	.354 [9.00]	.354 [9.00]	.117 [2.96]
12	.472 [12.00]	.433 [11.00]	.551 [14.00]	.688 [17.48]	.609 [15.47]	.394 [10.00]	.394 [10.00]	.136 [3.46]
13	.512 [13.00]	.472 [12.00]	.591 [15.00]	.728 [18.48]	.648 [16.47]	.433 [11.00]	.433 [11.00]	.156 [3.96]
14	.551 [14.00]	.512 [13.00]	.630 [16.00]	.767 [19.48]	.688 [17.47]	.472 [12.00]	.472 [12.00]	.176 [4.46]
15	.591 [15.00]	.551 [14.00]	.669 [17.00]	.806 [20.48]	.727 [18.47]	.512 [13.00]	.512 [13.00]	.195 [4.96]
16	.630 [16.00]	.591 [15.00]	.709 [18.00]	.846 [21.48]	.767 [19.47]	.551 [14.00]	.551 [14.00]	.215 [5.46]
17	.669 [17.00]	.630 [16.00]	.748 [19.00]	.885 [22.48]	.806 [20.47]	.591 [15.00]	.591 [15.00]	.235 [5.96]
18	.709 [18.00]	.669 [17.00]	.787 [20.00]	.924 [23.48]	.845 [21.47]	.630 [16.00]	.630 [16.00]	.254 [6.46]
19	.748 [19.00]	.709 [18.00]	.827 [21.00]	.964 [24.48]	.885 [22.47]	.669 [17.00]	.669 [17.00]	.274 [6.96]
20	.787 [20.00]	.748 [19.00]	.866 [22.00]	1.003 [25.48]	.924 [23.47]	.709 [18.00]	.709 [18.00]	.294 [7.46]
21	.827 [21.00]	.787 [20.00]	.906 [23.00]	1.043 [26.48]	.963 [24.47]	.748 [19.00]	.748 [19.00]	.313 [7.96]
22	.866 [22.00]	.827 [21.00]	.945 [24.00]	1.082 [27.48]	1.003 [25.47]	.787 [20.00]	.787 [20.00]	.333 [8.46]
23	.906 [23.00]	.866 [22.00]	.984 [25.00]	1.121 [28.48]	1.042 [26.47]	.827 [21.00]	.827 [21.00]	.353 [8.96]
24	.945 [24.00]	.906 [23.00]	1.024 [26.00]	1.161 [29.48]	1.081 [27.47]	.866 [22.00]	.866 [22.00]	.372 [9.46]
25	.984 [25.00]	.945 [24.00]	1.063 [27.00]	1.200 [30.48]	1.121 [28.47]	.906 [23.00]	.906 [23.00]	.392 [9.96]
26	1.024 [26.00]	.984 [25.00]	1.102 [28.00]	1.239 [31.48]	1.160 [29.47]	.945 [24.00]	.945 [24.00]	.412 [10.46]
27	1.063 [27.00]	1.024 [26.00]	1.142 [29.00]	1.279 [32.48]	1.200 [30.47]	.984 [25.00]	.984 [25.00]	.431 [10.96]
28	1.102 [28.00]	1.063 [27.00]	1.181 [30.00]	1.318 [33.48]	1.239 [31.47]	1.024 [26.00]	1.024 [26.00]	.451 [11.46]
29	1.142 [29.00]	1.102 [28.00]	1.220 [31.00]	1.357 [34.48]	1.278 [32.47]	1.063 [27.00]	1.063 [27.00]	.471 [11.96]
30	1.181 [30.00]	1.142 [29.00]	1.260 [32.00]	1.397 [35.48]	1.318 [33.47]	1.102 [28.00]	1.102 [28.00]	.491 [12.46]
31	1.220 [31.00]	1.181 [30.00]	1.299 [33.00]	1.436 [36.48]	1.357 [34.47]	1.142 [29.00]	1.142 [29.00]	.510 [12.96]
32	1.260 [32.00]	1.220 [31.00]	1.339 [34.00]	1.476 [37.48]	1.396 [35.47]	1.181 [30.00]	1.181 [30.00]	.530 [13.46]
33	1.299 [33.00]	1.260 [32.00]	1.378 [35.00]	1.515 [38.48]	1.436 [36.47]	1.220 [31.00]	1.220 [31.00]	.550 [13.96]
34	1.339 [34.00]	1.299 [33.00]	1.417 [36.00]	1.554 [39.48]	1.475 [37.47]	1.260 [32.00]	1.260 [32.00]	.569 [14.46]
35	1.378 [35.00]	1.339 [34.00]	1.457 [37.00]	1.594 [40.48]	1.515 [38.47]	1.299 [33.00]	1.299 [33.00]	.589 [14.96]
36	1.417 [36.00]	1.378 [35.00]	1.496 [38.00]	1.633 [41.48]	1.554 [39.47]	1.339 [34.00]	1.339 [34.00]	.609 [15.46]
37	1.457 [37.00]	1.417 [36.00]	1.535 [39.00]	1.672 [42.48]	1.593 [40.47]	1.378 [35.00]	1.378 [35.00]	.628 [15.96]
38	1.496 [38.00]	1.457 [37.00]	1.575 [40.00]	1.712 [43.48]	1.633 [41.47]	1.417 [36.00]	1.417 [36.00]	.648 [16.46]
39	1.535 [39.00]	1.496 [38.00]	1.614 [41.00]	1.751 [44.48]	1.672 [42.47]	1.457 [37.00]	1.457 [37.00]	.668 [16.96]
40	1.575 [40.00]	1.535 [39.00]	1.654 [42.00]	1.791 [45.48]	1.711 [43.47]	1.496 [38.00]	1.496 [38.00]	.687 [17.46]
41	1.614 [41.00]	1.575 [40.00]	1.693 [43.00]	1.830 [46.48]	1.751 [44.47]	1.535 [39.00]	1.535 [39.00]	.707 [17.96]
42	1.654 [42.00]	1.614 [41.00]	1.732 [44.00]	1.869 [47.48]	1.790 [45.47]	1.575 [40.00]	1.575 [40.00]	.727 [18.46]
43	1.693 [43.00]	1.654 [42.00]	1.772 [45.00]	1.909 [48.48]	1.830 [46.47]	1.614 [41.00]	1.614 [41.00]	.746 [18.96]
44	1.732 [44.00]	1.693 [43.00]	1.811 [46.00]	1.948 [49.48]	1.869 [47.47]	1.654 [42.00]	1.654 [42.00]	.766 [19.46]
45	1.772 [45.00]	1.732 [44.00]	1.850 [47.00]	1.987 [50.48]	1.908 [48.47]	1.693 [43.00]	1.693 [43.00]	.786 [19.96]
46	1.811 [46.00]	1.772 [45.00]	1.890 [48.00]	2.027 [51.48]	1.948 [49.47]	1.732 [44.00]	1.732 [44.00]	.806 [20.46]
47	1.850 [47.00]	1.811 [46.00]	1.929 [49.00]	2.066 [52.48]	1.987 [50.47]	1.772 [45.00]	1.772 [45.00]	.825 [20.96]
48	1.890 [48.00]	1.850 [47.00]	1.969 [50.00]	2.106 [53.48]	2.026 [51.47]	1.811 [46.00]	1.811 [46.00]	.845 [21.46]
49	1.929 [49.00]	1.890 [48.00]	2.008 [51.00]	2.145 [54.48]	2.066 [52.47]	1.850 [47.00]	1.850 [47.00]	.865 [21.96]
50	1.969 [50.00]	1.929 [49.00]	2.047 [52.00]	2.184 [55.48]	2.106 [53.47]	1.890 [48.00]	1.890 [48.00]	.884 [22.46]

**PROPRIETARY NOTE**  
 THIS DOCUMENT CONTAINS CONFIDENTIAL AND PROPRIETARY INFORMATION AND ALL DESIGN, MANUFACTURING, REPRODUCTION, USE, PATENT RIGHTS AND SALES RIGHTS ARE EXPRESSLY RESERVED BY SAMTEC, INC. THIS DOCUMENT SHALL NOT BE DISCLOSED, IN WHOLE OR PART, TO ANY UNAUTHORIZED PERSON OR ENTITY NOR REPRODUCED, TRANSFERRED OR INCORPORATED IN ANY OTHER PROJECT IN ANY MANNER WITHOUT THE EXPRESS WRITTEN CONSENT OF SAMTEC, INC.



520 PARK EAST BLVD, NEW ALBANY, IN 47150  
 PHONE: 812-944-6733 FAX: 812-948-5047  
 e-Mail info@SAMTEC.com code 55322

DO NOT SCALE DRAWING

SHEET SCALE: 5:1

DESCRIPTION:  
 1mm x 1mm SM BOARD STACKER ASSEMBLY  
 DWG. NO.  
**MW-XX-03-X-D-XXX-XXX-XX-X-XX**  
 BY: BRATCHER 4/3/1995 SHEET 5 OF 5