

APPROVAL SHEET



WLAC292 Series
SMD Air Wound Coil Inductors

*Contents in this sheet are subject to change without prior notice.

Features

Acrylic jacket(WLAC292) provides a flat top for pick and place

1. Acrylic cap provides a flat top for pick and place machine for high productive manufacture.
2. Excellent Q and SRF characteristics for RF application, espically in subGHz band.
3. Narrow tolerance available for precise design requirements.

Applications

1. Communication system front-end circuit: GSM/3G/LTE, Wi-Fi, GPS.
2. Cabel/Terrestrial/BS Tuner, Bluetooth, Wireless Audio, Remote control.
3. M2M: ZigBee, Proprietary wilreless.
4. EMI solution in high frequency circuits.

Shape and Dimension

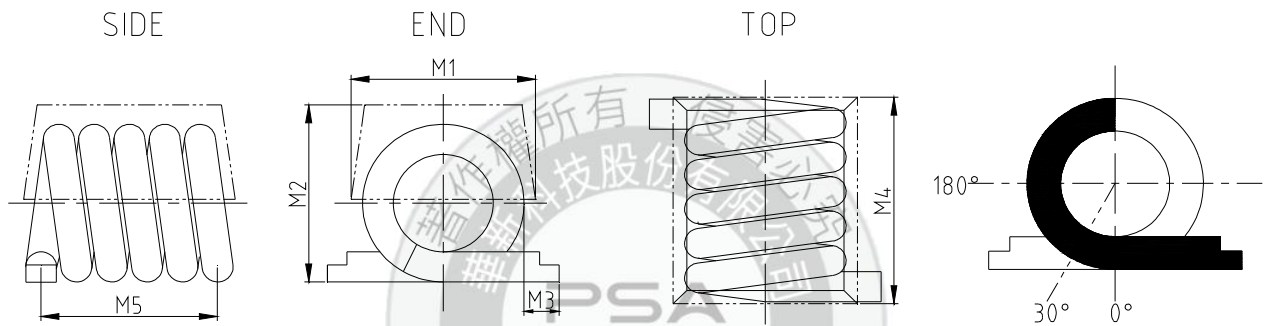

Recommend Patterns

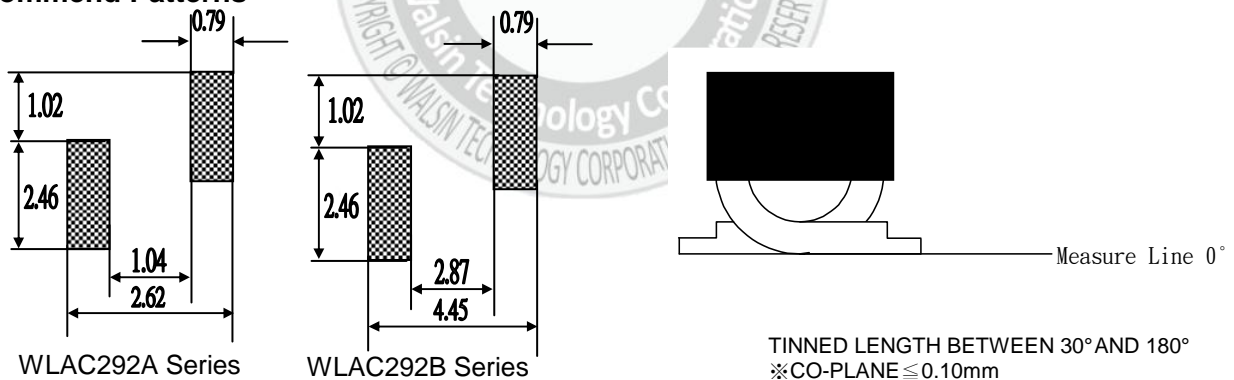

Unit: mm

WLAC Series	M1	M2	M3	M4	M5
292A	1.42±0.13	1.37±0.15	0.89±0.25	2.21±0.25	1.83±0.25
292B	1.42±0.13	1.37±0.15	0.89±0.25	4.04±0.30	3.66±0.30

Ordering Information

WL	AC	292A	Z0	K	T02	P	B
Product Code	Series	Dimensions	Series Extension	Tolerance	Value	Packing Code	
WL: Inductor	Air wound coil inductor.	292A 292B	Z0:STD	G: ± 2% J: ± 5% K: ± 10%	T02 = 2Turns T10 =10Turns	P=7" Reeled (Embossed reel)	B:STD

Electrical Characteristics

● WLAC292 series

Walsin Part Number	Turns	L(nH)	Tolerance	Q Min	Typical Q @ Frequency (MHz)	SRF Maximum (GHz)	RDC Maximum (mΩ)	Rated Current Maximum (A)
WLAC292AZ0□T02PB	2	1.65	J、K	100	800	10	4	1.6
WLAC292AZ0□T03PB	3	2.55	G、J、K	100	800	8.2	5	1.6
WLAC292AZ0□T04PB	4	3.85	G、J、K	100	800	7.5	6	1.6
WLAC292AZ0□T05PB	5	5.4	G、J	100	800	7	8	1.6
WLAC292BZ0□T06PB	6	5.6	G、J	100	800	6.5	9	1.6
WLAC292BZ0□T07PB	7	7.15	G、J	100	800	6	10	1.6
WLAC292BZ0□T08PB	8	8.8	G、J	100	800	6	12	1.6
WLAC292BZ0□T09PB	9	9.85	G、J	100	800	5.2	13	1.6
WLAC292BZ0□T10PB	10	12.55	G、J	100	800	4.6	14	1.6

TOLERANCE : G=±2%, J=±5%, K=±10%

※TEST INSTRUMENT: HP4291B、FIXTURE HP16193A、HP8753E、CHROMA16502

NOTE : 1. Inductance & Q measured on the HP4291B. With HP16193A test fixture.

2. SRF measured using the HP8753E
3. Operating temperature range: -40°C to +125°C.
4. Electrical specifications at 25°C.
5. MSL : LEVEL 1

RELIABILITY PERFORMANCE

Reliability Experiment For Electrical

Test Item	Test Condition	Standard Source
Humidity Test	+40°C ± 2°C, humidity of 90% ± 5% (total 96 hours).	MIL-STD-202G Method 103B Test Condition B
High Temperature Test	1. Temperature: +125°C ± 2°C 2. Test time: 48 ± 2hrs	IEC 68-2 Test Condition B
Low Temperature Test	1. Temperature: -40°C ± 2°C 2. Test time: 48 ± 2hrs	IEC 68-2 Test Condition A
Thermal Shock	+125°C ± 5°C (30 minutes) ~ -40 ± 5°C (30 minutes), temperature switch time: 5 minutes (total 50 cycles).	MIL-STD-202G Method 107G Test Condition B-2
Life Test	+70°C ± 5°C (250Hours)	MIL-STD-202G Method 108A Test Condition B

Reliability Experiment For Physical

Test Item	Test Condition	Standard Source
Vibration Test	10-55-10HZ, amplitude: 1.5mm, direction: X, Y, Z axes, each axis 2 hours (total 6 hours).	MIL-STD-202G Method 201A
Solder Heat Resistance Test	IR/convection reflow: Peak Temp 250 ± 5°C for 5Sec in air, Through 2 Cycle. Temperature Ramp: +1 ~ 4°C/sec; Above 183°C, must keep 90 s - 120 s	MIL-STD-202G Method 210F Test Condition (Reflow)
Solder Ability Test	Soak in 245 °C solder pot of 3Sec, PAD must have 95% above coverage.	J-STD-003B

Typical RoHS Reflow Profile

Typical RoHS Reflow Profile

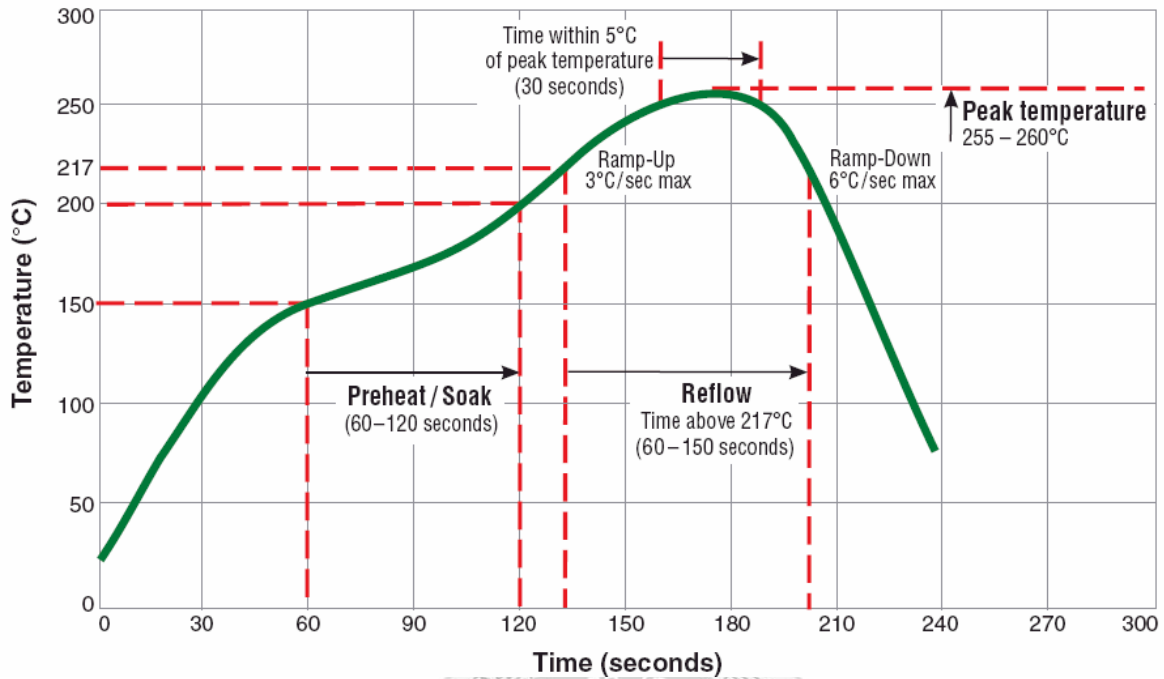

Packaging Specification (WLAC292 Series)

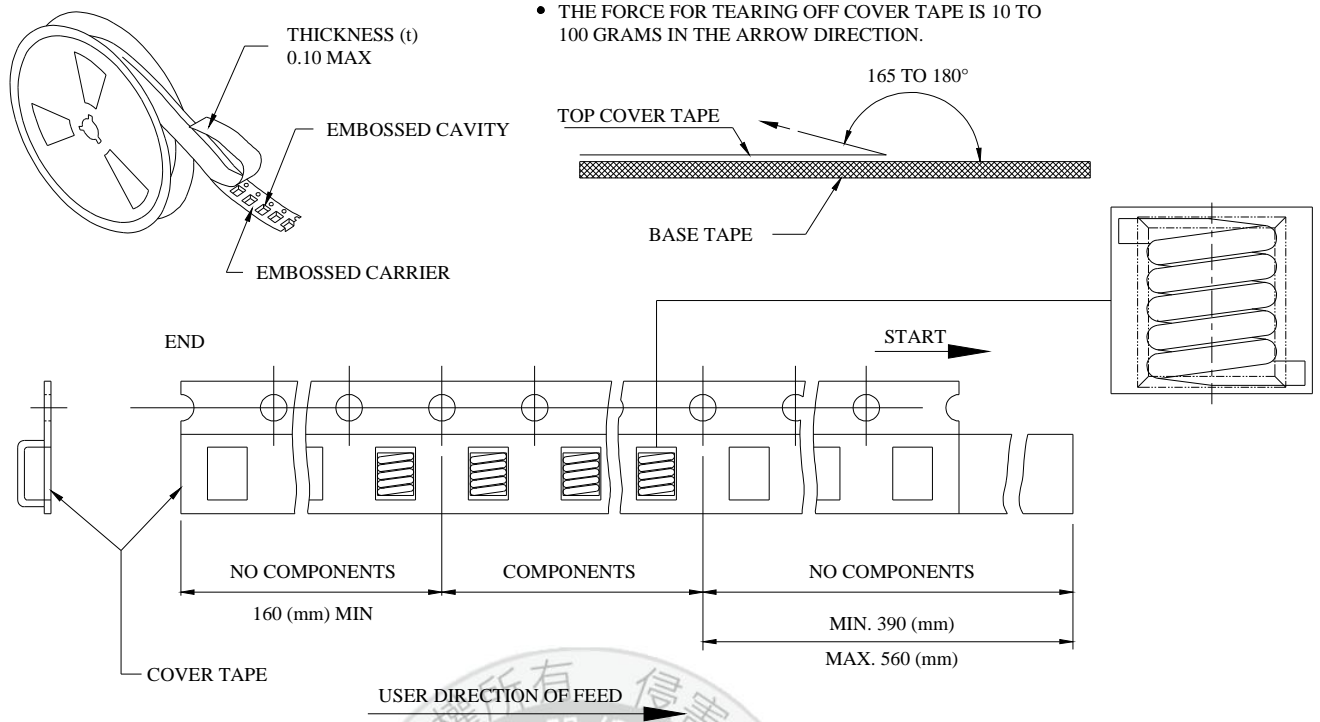

■ CARRIER TAPE REELS (mm)

MATERIAL: PLASTIC

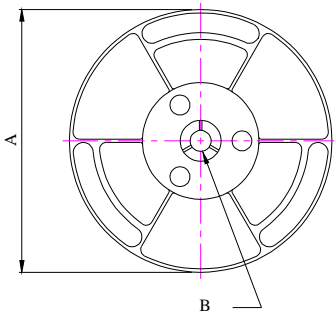

■ DIMENSIONS OF CARRIER TAPE (mm)

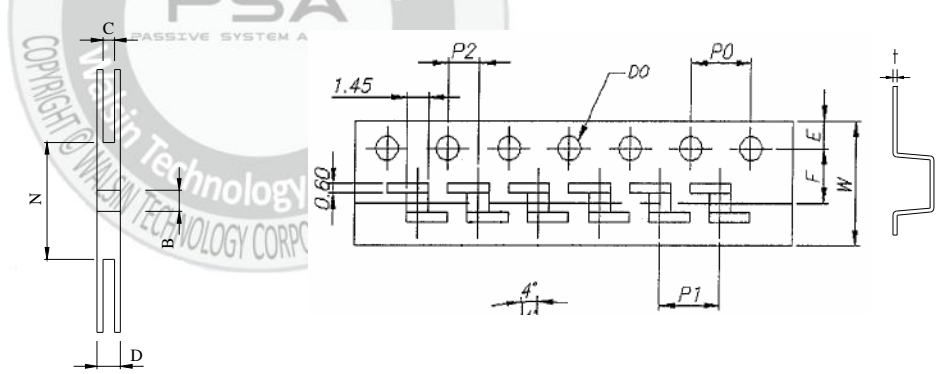

Unit : mm

	A	B	C	D	E	F	N	t	W	D0	P0	P1	P2
292A	A	B	C	D	E	F	N	t	W	D0	P0	P1	P2
DIM.	178	13	8.4	12.5	1.75	3.50	75	0.23	8.0	1.50	4.00	4.00	2.00
TOL.	±2.0	±0.8	+1.5 -0	+1.5 -0	±0.10	±0.10	±2.0	±0.05	±0.20	+0.10 -0	±0.10	±0.10	±0.10
292B	A	B	C	D	E	F	N	t	W	D0	P0	P1	P2
DIM.	180	13	12.4	16.8	1.75	3.50	50	0.35	12	1.50	4.00	4.00	2.00
TOL.	MAX.	+0.5 -0.2	+2 -0	MAX.	±0.10	±0.10	MIN.	±0.05	±0.30	+0.10 -0	±0.10	±0.10	±0.10

Quantity per reel : 2K pcs