

DRAWING MADE IN THIRD ANGLE PROJECTION

THIS DRAWING IS UNPUBLISHED. RELEASED FOR PUBLICATION .19
 © COPYRIGHT 19 BY AMP INCORPORATED. ALL INTERNATIONAL RIGHTS RESERVED.

LOC	DIST	P	F	REVISIONS		DATE	APPD
AF	50			ZONE	LTR	DESCRIPTION	
				P		REV & REDRAWN PER AF-6955	9/5/90 DK5

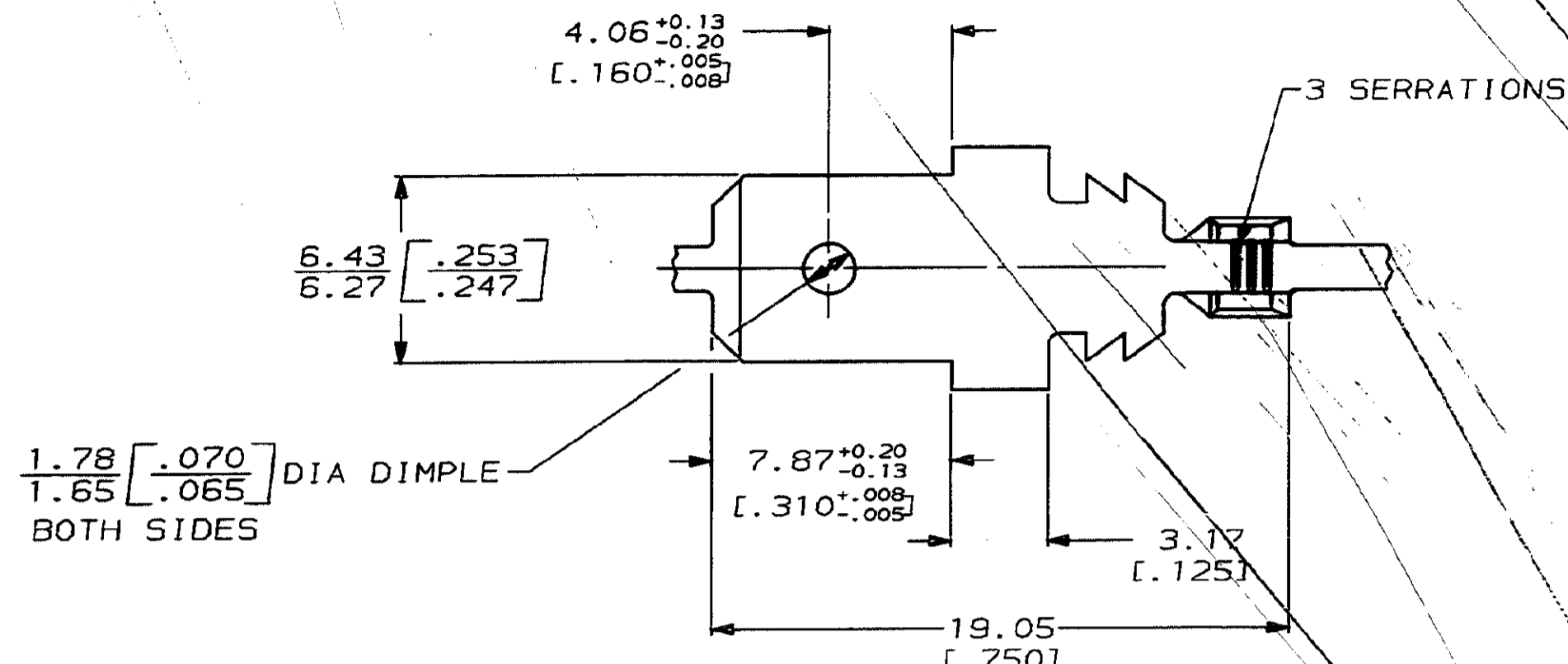

- 1 WIRE RANGE: 0.20-0.32mm² [#32-#28] AWG
- 2 PRE-STRIPPING OF THE MAGNET WIRE IS NOT REQUIRED
- 3 TIN PL 0.002032[.000080] MIN THK PER MIL-T-10727

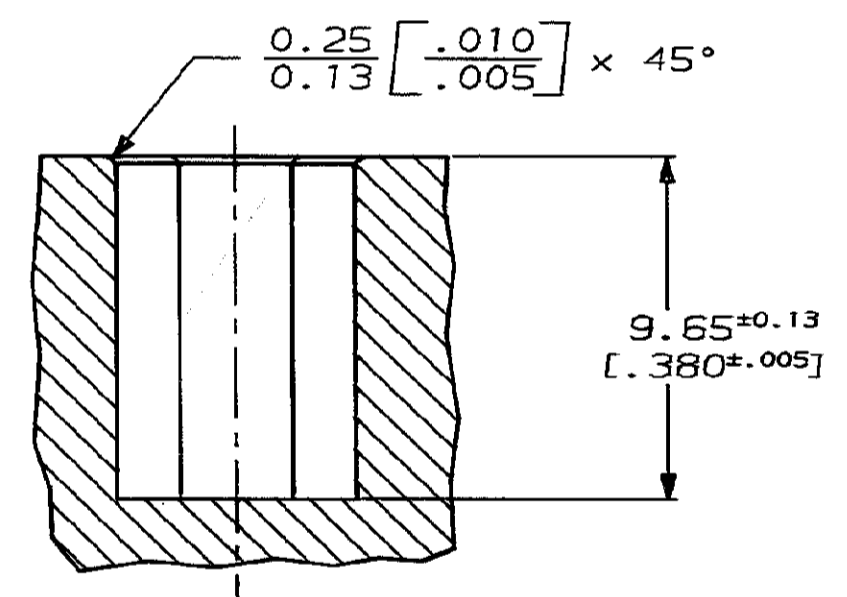
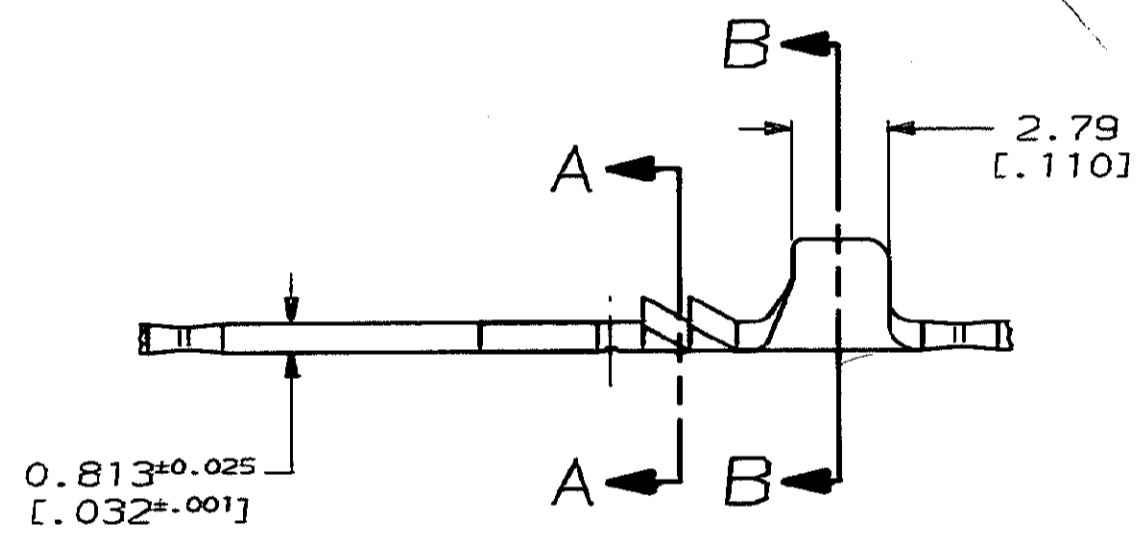
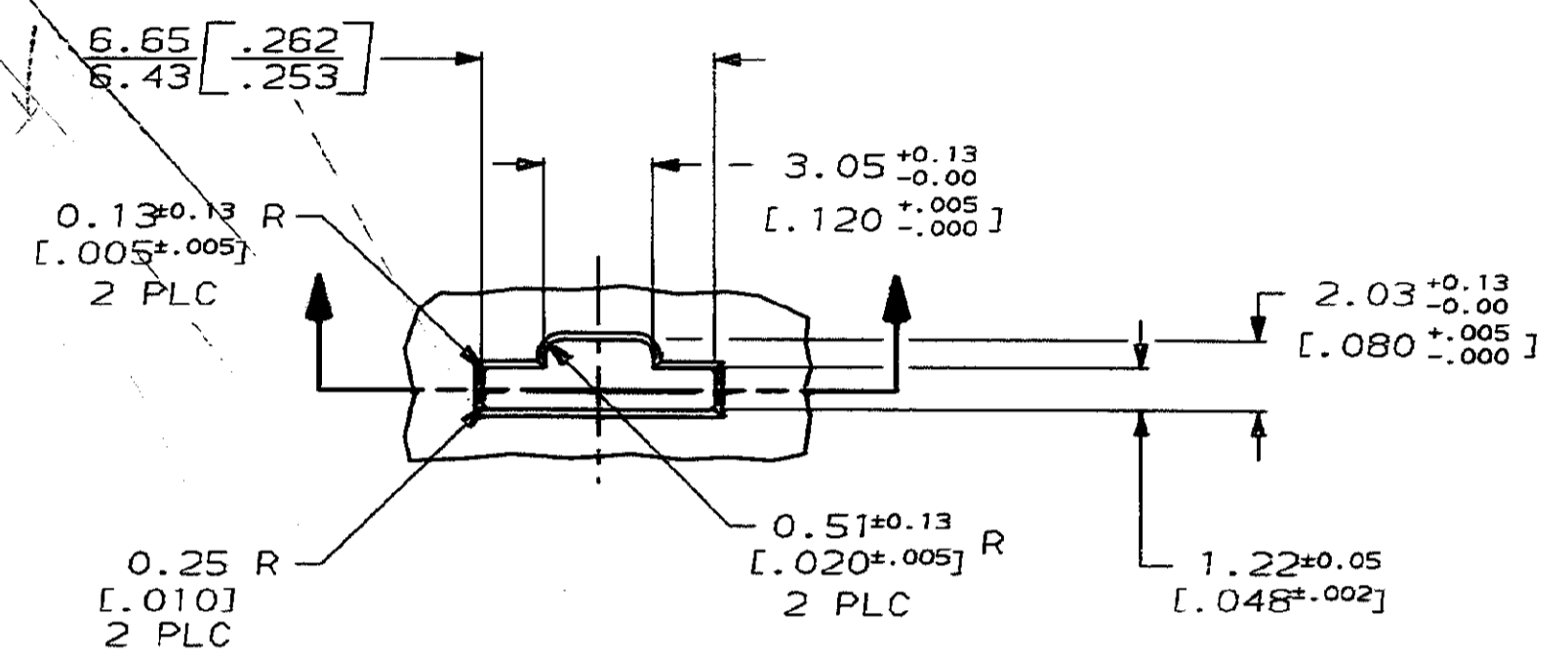

RECOMMENDED CAVITY SIZE

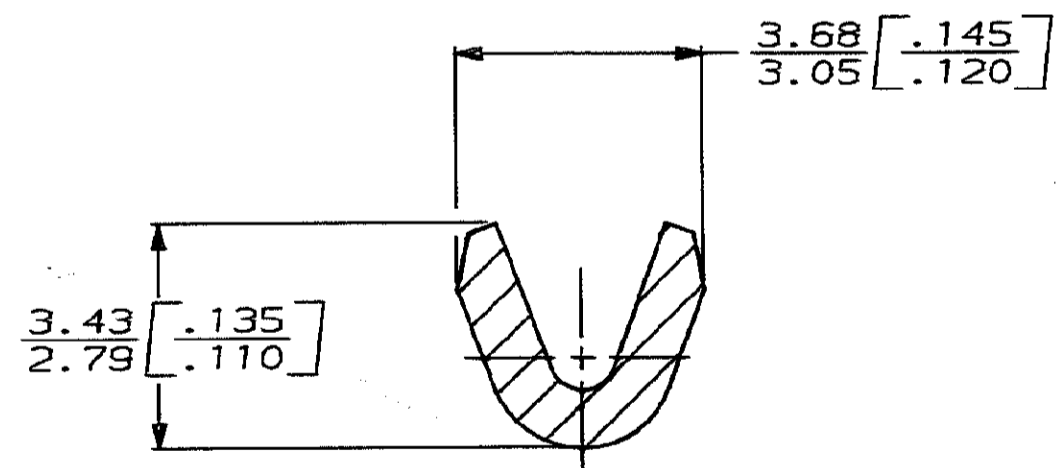

SECTION B-B
SCALE 10:1

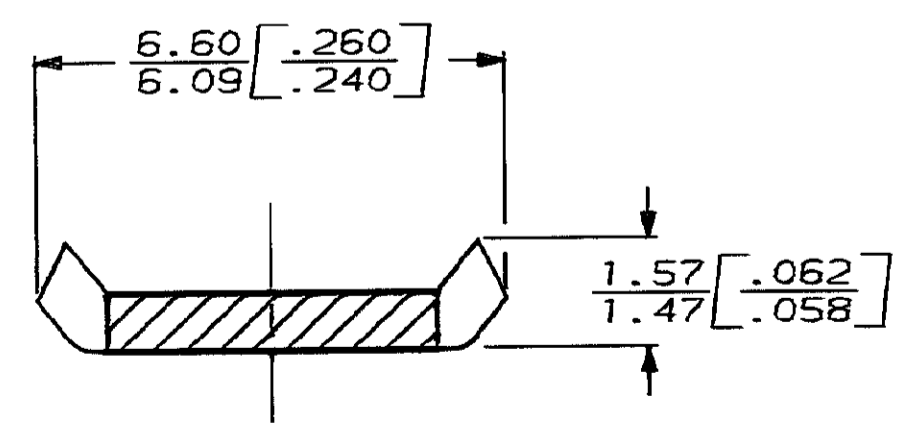

SECTION A-A
SCALE 10:1

METRIC

DO NOT SCALE PRINT. UNLESS SPECIFIED DIMENSIONS IN mm [INCHES] TOLERANCES ON: 2 PLC DEC ± 0.38[.015] 3 PLC DEC ± - ANGLES ± -	DR 9/5/90 DK SCHRUM	OBSOLETE		61598-2
	CHK 9/11/90 MS FEHER	NONE		61598-1
MATERIAL	APPD 9/13/90 D SCHWENK	FINISH		PART NO
#2 HARD BRASS	APPD 9/25/90 R. WEAUVILL	AMP Incorporated Harrisburg, PA 17105-3608		
FINISH	APPLICATION SPEC	NAME		
SEE TABLE	-	BOBBIN TAB, AMPLIVAR™		
WEIGHT	-	SIZE	CAGE CODE	DRAWING NO
		C	00779	61598
		SCALE	5:1	SHEET 1 OF 1

CUSTOMER DRAWING