



Low-Power Single/Dual-Supply Quad Comparator with Reference

FEATURES

- ◆ Ultra-Low Quiescent Current: 5.1µA (max), All comparators plus Reference
- ◆ Single or Dual Power Supplies:
 - Single: +2.5V to +11V
 - Dual: ±1.25V to ±5.5V
- ◆ Input Voltage Range Includes Negative Supply
- ◆ 7µs Propagation Delay
- ◆ Push-pull TTL/CMOS-Compatible Outputs
- ◆ Separate Output GND Pin
- ◆ Crowbar-Current-Free Switching
- ◆ Continuous Source Current Capability: 40mA
- ◆ Internal 1.182V ±1% Reference
- ◆ 16-pin Narrow SOIC Package

APPLICATIONS

- Threshold Detectors
- Window Comparator
- Level Translators
- Oscillator Circuits
- Battery-Powered Systems

DESCRIPTION

The TS9004 low-voltage, micropower quad analog comparator is form-factor identical to the MAX934 analog comparator with improved electrical specifications. Ideal for 3V or 5V single-supply applications, the TS9004 draws 22% lower supply current with a 50%-better initial accuracy reference voltage. The TS9004 joins the TS9001-1/2 and TS9002 analog comparators in the "NanoWatt Analog™" high performance analog integrated circuits portfolio. This quad comparator can operate from single +2.5V to +11V supplies or from ±1.25V to ±5.5V dual supplies.

The TS9004 exhibits an input voltage range from the negative supply rail to within 1.3V of the positive supply. In addition, its push-pull output stage is TTL/CMOS compatible and capable of sinking and sourcing current. It also incorporates an internal 1.182V ±1% voltage reference. A GND connection available at the TS9004's output stage enables TTL compatibility and bipolar-to-single ended conversion.

The TS9004 is fully specified over the -40°C to +85°C temperature range and is available in a 16-pin narrow SOIC package.

TYPICAL APPLICATION CIRCUIT

Using a TS9004 in a 5V Bar-Graph Level Gauge Application

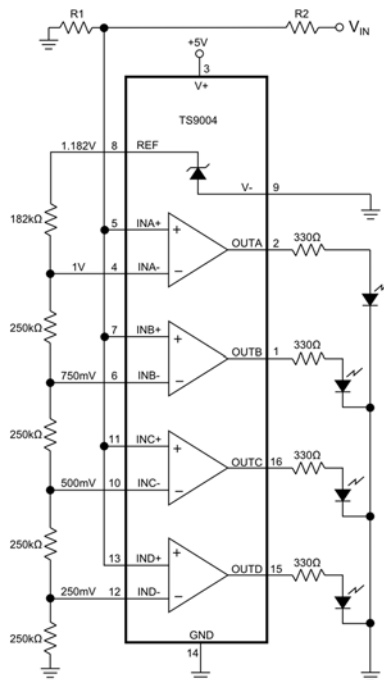

ABSOLUTE MAXIMUM RATINGS

Supply Voltage (V+ to V-, V+ to GND, GND to V-).....-0.3V, +12V
 Voltage Inputs
 (IN+, IN-).....(V+ + 0.3V) to (V- - 0.3V)
 Output Voltage
 REF..... (V+ + 0.3V) to (V- - 0.3V)
 OUT(V+ + 0.3V) to (GND - 0.3V)
 Input Current (IN+, IN-).....20mA
 Output Current
 REF.....20mA
 OUT.....40mA
 Output Short-Circuit Duration (V+ ≤ 5.5V)Continuous

Continuous Power Dissipation (T_A = +70°C)
 16-Pin SOIC (derate 8.7mW/°C above +70°C)696mW
 Operating Temperature Ranges.....-40°C to +85°C
 Storage Temperature Range-65°C to +150°C
 Lead Temperature (soldering, 10s)+300°C

Electrical and thermal stresses beyond those listed under “Absolute Maximum Ratings” may cause permanent damage to the device. These are stress ratings only and functional operation of the device at these or any other condition beyond those indicated in the operational sections of the specifications is not implied. Exposure to any absolute maximum rating conditions for extended periods may affect device reliability and lifetime.

PACKAGE/ORDERING INFORMATION

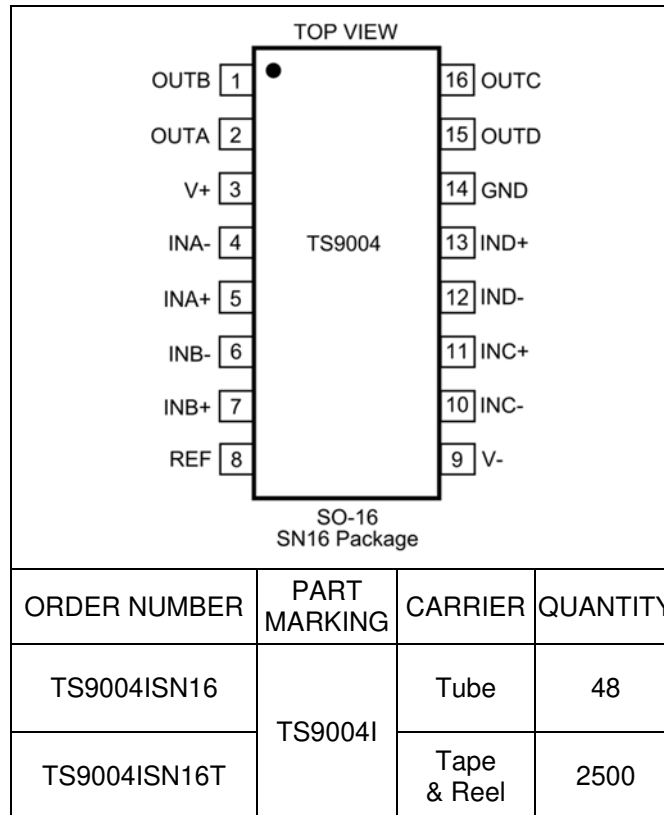

Lead-free Program: Silicon Labs supplies only lead-free packaging.

Consult Silicon Labs for products specified with wider operating temperature ranges.



ELECTRICAL CHARACTERISTICS – 5V OPERATION

V+ = 5V, V- = GND = 0V; TA = -40°C to +85°C, unless otherwise noted. Typical values are at TA = +25°C. See Note 1.

PARAMETER	CONDITIONS		MIN	TYP	MAX	UNITS	
POWER REQUIREMENTS							
Supply Voltage Range	See Note 2		2.5		11	V	
Supply Current	IN+ = IN- + 100mV	TA = +25°C		4.1	5.1	µA	
		-40°C to +85°C			8		
COMPARATOR							
Input Offset Voltage	VCM = 2.5V	TA = +25°C			±4.5	mV	
		-40°C to +85°C			±10		
Input Leakage Current (IN-, IN+)	IN+ = IN- = 2.5V	TA = +25°C		±0.01	±2	nA	
		-40°C to +85°C		±0.01	±5		
Input Common-Mode Voltage Range			V-		V+ - 1.3V	V	
Common-Mode Rejection Ratio	V- to (V+ - 1.3V)			0.1	1	mV/V	
Power-Supply Rejection Ratio	V+ = 2.5V to 11V			0.1	1	mV/V	
Output Voltage Noise	100Hz to 100kHz			20		µV _{RMS}	
Response Time (High-to-Low Transition)	TA = +25°C, 100pF Load	Overdrive = 10 mV		17		µs	
		Overdrive = 100 mV		7			
Response Time (Low-to-High Transition)	TA = +25°C, 100pF Load	Overdrive = 10 mV		17		µs	
		Overdrive = 100 mV		7			
Output High Voltage		-40°C to +85°C; IOUT = 17mA	V+ - 0.4			V	
Output Low Voltage		-40°C to +85°C; IOUT = 1.8mA			GND + 0.4	V	
	Dual Supply	-40°C to +85°C; IOUT = 1.8mA			V- + 0.4	V	
REFERENCE							
Reference Voltage			TA = +25°C	1.170	1.182	1.194	V
			-40°C to +85°C	1.158		1.206	
Reference Line Regulation	2.5V ≤ (V+ - V-) ≤ 5V		TA = +25°C		0.25		mV/V
Source Current	ΔVREF = 1%	TA = +25°C		20	25	µA	
		-40°C to +85°C		6			
Sink Current	ΔVREF = 1%	TA = +25°C		10	15	µA	
		-40°C to +85°C		4			
Output Voltage Noise	100Hz to 100kHz			100		µV _{RMS}	

ELECTRICAL CHARACTERISTICS – 3V OPERATION

V₊ = 3V, V₋ = GND = 0V; T_A = -40°C to +85°C, unless otherwise noted. Typical values are at T_A = +25°C. See Note 1.

PARAMETER	CONDITIONS		MIN	TYP	MAX	UNITS	
POWER REQUIREMENTS							
Supply Current	IN+ = IN- + 100mV		T _A = +25°C	3.8	4.8	μA	
			-40°C to +85°C		6.5		
COMPARATOR							
Input Offset Voltage	V _{CM} = 1.5V		T _A = +25°C		±4.5	mV	
			-40°C to +85°C		±10		
Input Leakage Current (IN-, IN+)	IN+ = IN- = 1.5V		T _A = +25°C	±0.01	±1	nA	
			-40°C to +85°C	±0.01	±2.5		
Input Common-Mode Voltage Range				V-	V+ - 1.3V	V	
Common-Mode Rejection Ratio	V- to (V+ - 1.3V)			0.2	1	mV/V	
Power-Supply Rejection Ratio	V+ = 2.5V to 11V			0.1	1	mV/V	
Output Voltage Noise	100Hz to 100kHz			20		μV _{RMS}	
Response Time (High-to-Low Transition)	T _A = +25°C, 100pF Load	Overdrive = 10 mV		17		μs	
		Overdrive = 100 mV		7			
Response Time (Low-to-High Transition)	T _A = +25°C, 100pF Load	Overdrive = 10 mV		17		μs	
		Overdrive = 100 mV		7			
Output High Voltage		-40°C to +85°C; I _{OUT} = 10mA		V+ - 0.4		V	
Output Low Voltage		-40°C to +85°C; I _{OUT} = 0.8mA			GND + 0.4	V	
	Dual Supply	-40°C to +85°C; I _{OUT} = 0.8mA			V- + 0.4	V	
REFERENCE							
Reference Voltage			T _A = +25°C	1.170	1.182	1.194	V
			-40°C to +85°C	1.158		1.206	
Reference Line Regulation	2.5V ≤ (V+ - V-) ≤ 3V		T _A = +25°C		0.25		mV/V
Source Current	ΔVREF = 1%		T _A = +25°C	20	25		μA
			-40°C to +85°C	6			
Sink Current	ΔVREF = 1%		T _A = +25°C	10	15		μA
			-40°C to +85°C	4			
Output Voltage Noise	100Hz to 100kHz			100			μV _{RMS}

Note 1: All specifications are 100% tested at T_A = +25°C. Specification limits over temperature (T_A = T_{MIN} to T_{MAX}) are guaranteed by device characterization, not production tested.

Note 2: The TS9004 comparator operates below 2.5V. Refer to the “Low-Voltage Operation: V+ = 1.5V” section.



TYPICAL PERFORMANCE CHARACTERISTICS

$V_+ = 5V$; $V_- = GND$; $T_A = +25^\circ C$, unless otherwise noted.

Output Voltage Low vs Load Current

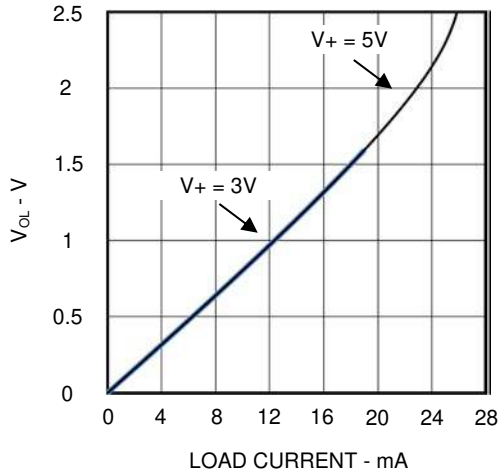

Output Voltage High vs Load Current

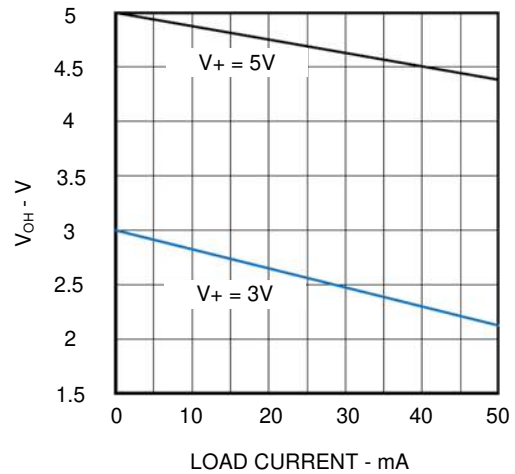

Reference Output Voltage vs Output Load Current

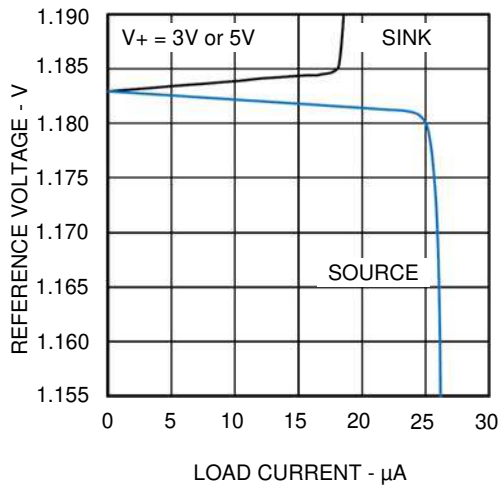

Reference Voltage vs Temperature

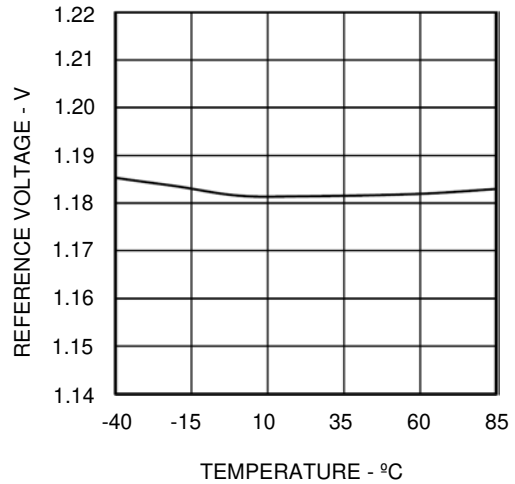

Supply Current vs Temperature

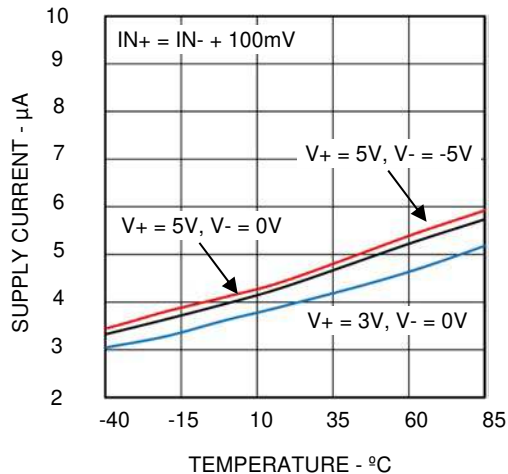

Supply Current vs Low Supply Voltages

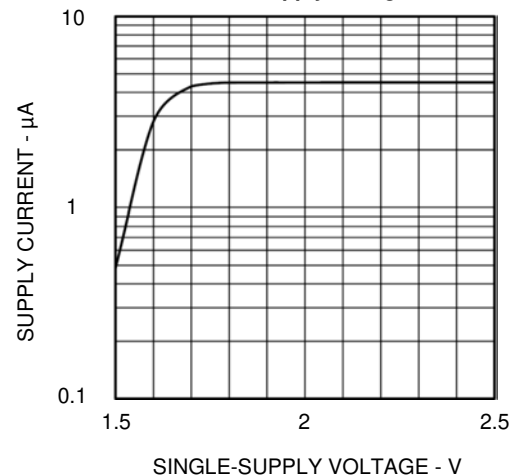

TYPICAL PERFORMANCE CHARACTERISTICS

$V_+ = 5V$; $V_- = GND$; $T_A = +25^\circ C$, unless otherwise noted.

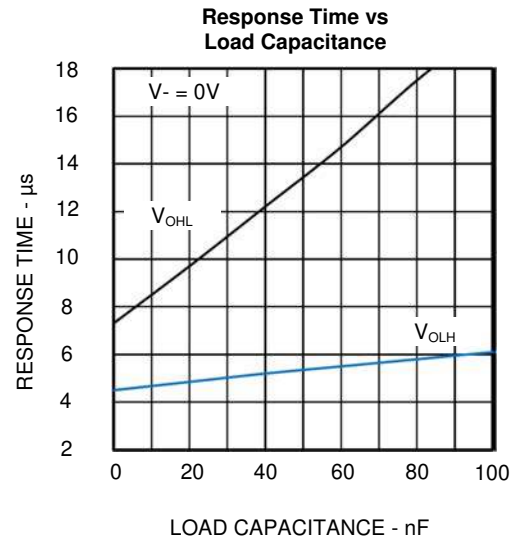
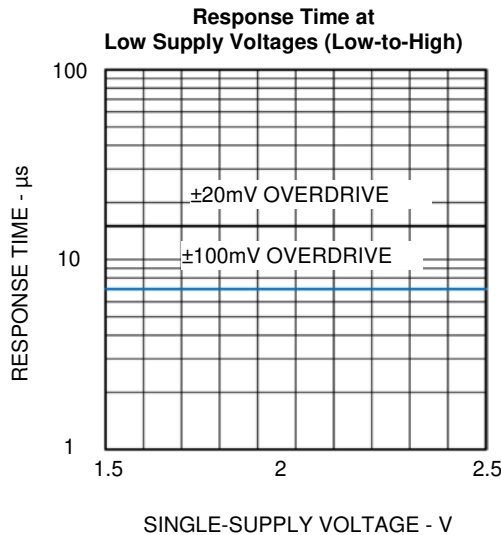
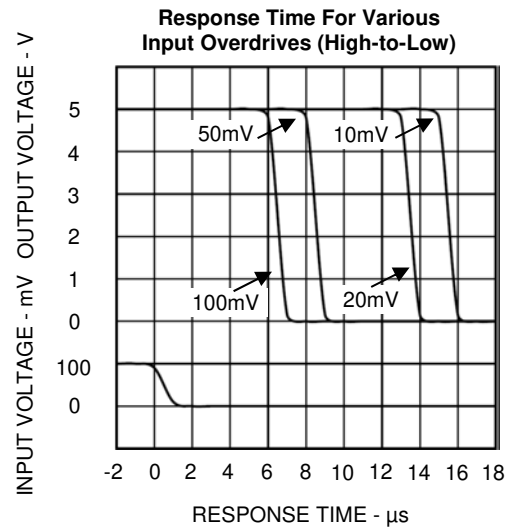
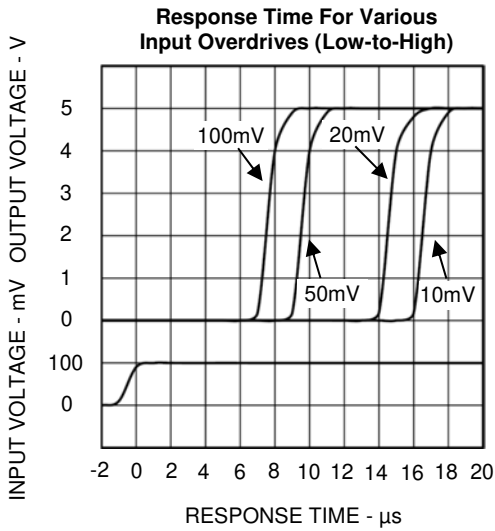
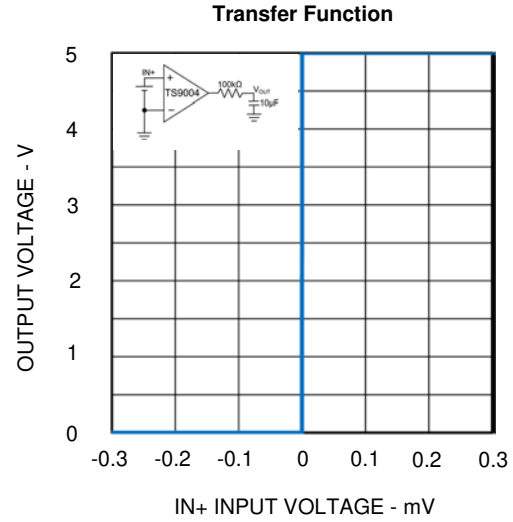
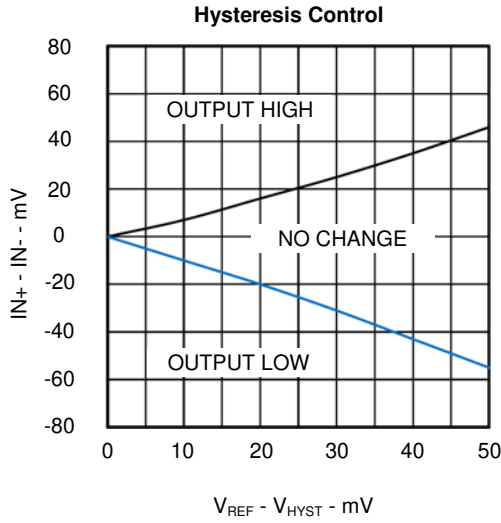



TYPICAL PERFORMANCE CHARACTERISTICS

$V_+ = 5V$; $V_- = GND$; $T_A = +25^\circ C$, unless otherwise noted.

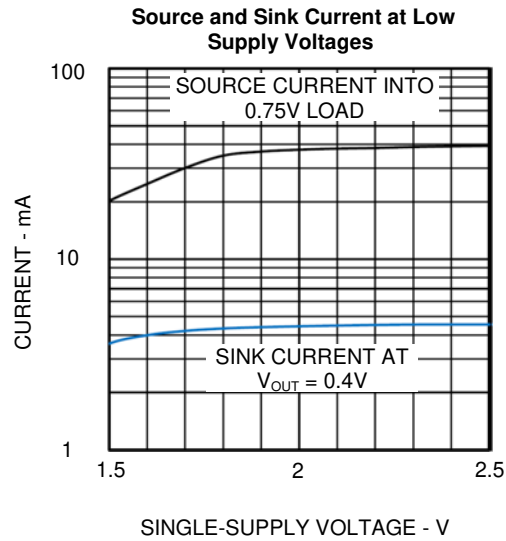
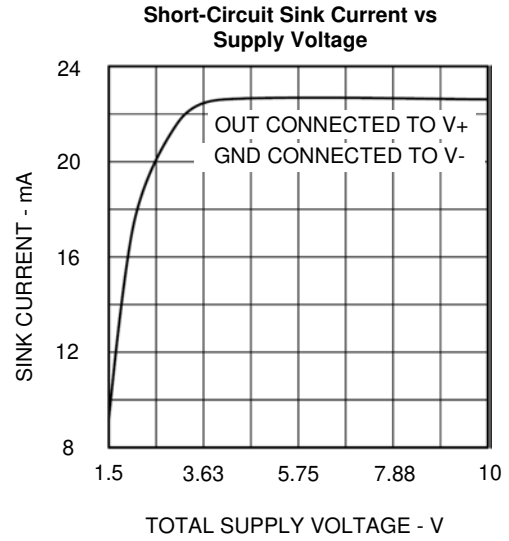
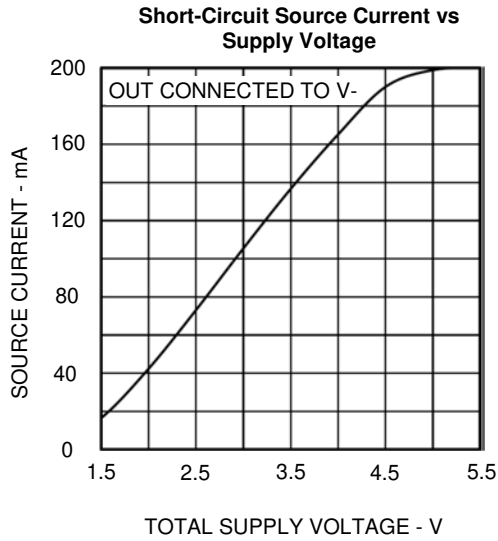

PIN FUNCTIONS

TS9004 SO-16	NAME	FUNCTION
1	OUTB	Comparator B Output. Sinks and sources current. Swings from V+ to GND.
2	OUTA	Comparator A Output. Sinks and sources current. Swings from V+ to GND.
3	V+	Positive Supply Voltage
4	INA-	Comparator A Inverting Input
5	INA+	Comparator A Noninverting Input
6	INB-	Comparator B Inverting Input
7	INB+	Comparator B Noninverting Input
8	REF	1.182V Reference Output with respect to V-.
9	V-	Negative Supply Voltage. Connect to ground for single-supply operation.
10	INC-	Comparator C Inverting Input
11	INC+	Comparator C Noninverting Input
12	IND-	Comparator D Inverting Input
13	IND+	Comparator D Noninverting Input
14	GND	Ground. Connect to V- for single-supply operation.
15	OUTD	Comparator D Output. Sinks and sources current. Swings from V+ to GND.
16	OUTC	Comparator C Output. Sinks and sources current. Swings from V+ to GND.

BLOCK DIAGRAM

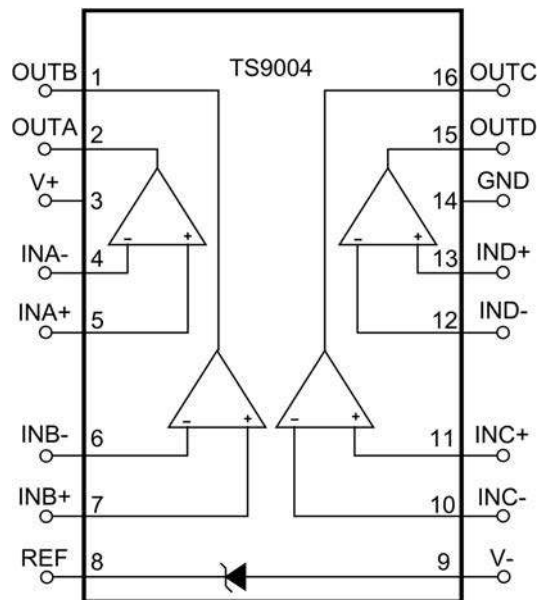



THEORY OF OPERATION

The TS9004 quad, low-voltage, micropower analog comparator provides excellent flexibility and performance while sourcing continuously up to 40mA of current. The TS9004 draws 8 μ A (max) for all 4 comparators, including the reference. It exhibits an input offset voltage of ± 4.5 mV, and has an on-board $+1.182$ V $\pm 0.75\%$ voltage reference. To minimize glitches that can occur with parasitic feedback or a less than optimal board layout, the design of the TS9004 output stage is optimized to eliminate crowbar glitches as the output switches.

Power-Supply and Input Signal Ranges

The TS9004 can operate from a single supply voltage range of $+2.5$ V to $+11$ V, provides a wide common mode input voltage range of V_- to $V_+ - 1.3$ V, and accept input signals ranging from V_- to $V_+ - 1$ V. The inputs can accept an input as much as 300mV above and below the power supply rails without damage to the part. While the TS9004 is able to operate from a single supply voltage range, a GND pin is available that allows for a dual supply operation with a range of ± 1.25 V to ± 5.5 V. If a single supply operation is desired, the GND pin needs to be tied to V_- . In a dual supply mode, the TS9004 is compatible with TTL/CMOS with a ± 5 V voltage.

Low-Voltage Operation: $V_+ = 1.5$ V

The TS9004 can operate down to a supply voltage of 2V; however, as the supply voltage reduces, the TS9004 supply current drops and the performance is degraded. When the supply voltage drops to 2.2V, the reference voltage will no longer function; however, the comparators will function down to a 1V supply voltage. Furthermore, the input voltage range is extended to just below 1V the positive supply rail. For applications with a sub-2.5V power supply, it is recommended to evaluate the circuit over the entire power supply range and temperature.

APPLICATIONS INFORMATION

Hysteresis

As a result of circuit noise or unintended parasitic feedback, many analog comparators often break into oscillation within their linear region of operation especially when the applied differential input voltage approaches 0V (zero volt). Externally-introduced hysteresis is a well-established technique to

Comparator Output

The TS9004 has a GND pin that allows the output to swing from V_+ to GND while the V_- pin can be set to a voltage below GND as long as the voltage difference between V_+ and V_- is within 11V. Having a different voltage on V_- will not affect the output swing. For TTL applications, V_+ can be set to $+5$ V $\pm 10\%$ and V_- can be set anywhere between 0V and -5 V $\pm 10\%$. Furthermore, the output design of the TS9004 can source and sink more than 40mA and 5mA, respectively, while simultaneously maintaining a quiescent current in the microampere range. If the power dissipation of the package is maintained within the max limit, the output can source pulses of 100mA of current with V_+ set to $+5$ V. In an effort to minimize external components needed to address power supply feedback, the TS9004 output does not produce crowbar switching current as the output switches. With a 10mV input overdrive, the propagation delay of the TS9004 is 17 μ s.

Voltage Reference

The TS9004 has an on-board 1.182V reference voltage with an accuracy of $\pm 0.75\%$. The REF pin is able to source and sink 20 μ A and 10 μ A of current, respectively. The REF pin is referenced to V_- and it should not be bypassed.

Noise Considerations

Noise can play a role in the overall performance of the TS9004. Despite having a large gain, if the input voltage is near or equal to the input offset voltage, the output will randomly switch HIGH and LOW. As a result, the TS9004 produces a peak-to-peak noise of about 0.3mV_{PP} while the reference voltage produces a peak-to-peak noise of about 1mV_{PP}. Furthermore, it is important to design a layout that minimizes capacitive coupling from a given output to the reference pin as crosstalk can add noise and as a result, degrade performance.

stabilizing analog comparator behavior and requires external components. As shown in Figure 1, adding comparator hysteresis creates two trip points: V_{THR} (for the rising input voltage) and V_{THF} (for the falling input voltage). The hysteresis band (V_{HB}) is defined as the voltage difference between the two trip points. When a comparator's input voltages are equal, hysteresis effectively forces one comparator input to move quickly past the other input, moving the input

out of the region where oscillation occurs. Figure 1 illustrates the case in which an IN- input is a fixed voltage and an IN+ is varied. If the input signals

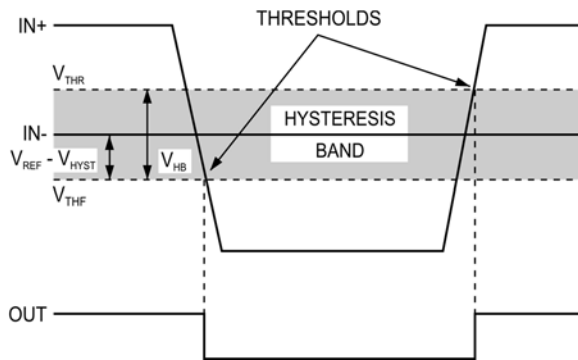

Figure 1. Threshold Hysteresis Band

were reversed, the figure would be the same with an inverted output. To add hysteresis to the TS9004, the circuit in Figure 2 is implemented and uses positive feedback along with two external resistors to set the desired hysteresis. The circuit consumes more current and it slows down the hysteresis effect

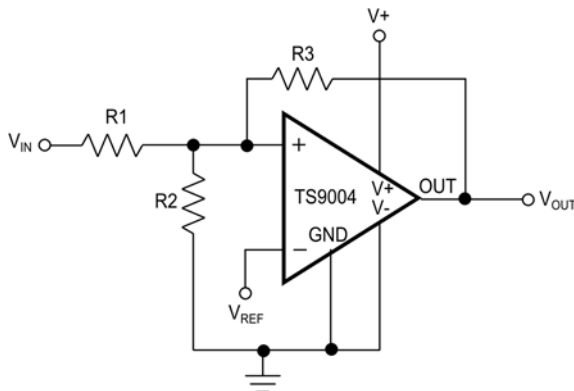

Figure 2. External Hysteresis

due to the high impedance on the feedback. The following procedure explains the steps to design the circuit for a desired hysteresis:

1. Choosing R3. As the leakage current at the IN+ pin is less than 1nA, the current through R3 should be at least 100nA to minimize offset voltage errors caused by the input leakage current. For R3 = 11.8MΩ, the current through R3 is V_REF/R3 at the trip point. In this case, a 10MΩ resistor is a good standard value for R3.
2. Next, the desired hysteresis band (V_HB) is set. In this example, V_HB is set to 50mV.

3. Calculating R1.

$$R1 = R3 \times \frac{V_{HB}}{V_+}$$

$$= 10M\Omega \times \frac{50mV}{5V}$$

$$= 100k\Omega$$

In this example, a 100kΩ, 1% standard value resistor is selected for R1.

4. Choose the trip point for V_IN rising (V_THR), which is the threshold voltage at which the comparator switches its output from low to high as V_IN rises above the trip point. In this example, choose V_THR = 3V.

5. Calculating R2.

$$R2 = \frac{1}{\left[\left(\frac{V_{THR}}{V_{REF} \times R1}\right) - \frac{1}{R1} - \frac{1}{R3}\right]}$$

$$= \frac{1}{\left[\left(\frac{3}{1.182V \times 100k\Omega}\right) - \frac{1}{100k\Omega} - \frac{1}{10M\Omega}\right]}$$

$$= 65.44k\Omega$$

In this example, a 64.9kΩ, 1% standard value resistor is selected for R2.

6. The last step is to verify the trip voltages and hysteresis band using the standard resistance values:

$$V_{THR} = V_{REF} \times R1 \times \left(\frac{1}{R1} + \frac{1}{R2} + \frac{1}{R3}\right)$$

$$V_{THF} = V_{THR} - \frac{(R1 \times V_+)}{R3}$$

Board Layout and Bypassing

While power-supply bypass capacitors are not typically required, it is good engineering practice to use 0.1μF bypass capacitors close to the device's power supply pins when the power supply impedance is high, the power supply leads are long, or there is excessive noise on the power supply traces. To reduce stray capacitance, it is also good engineering practice to make signal trace lengths as short as possible. Also recommended are a ground plane and surface mount resistors and capacitors.



Bar-Graph Level Gauge

A simple four-stage level detector is shown in Figure 3 using the TS9004. Due to its high output source capability, the TS9004 is perfect for driving LEDs. When all of the LEDs are on, the threshold voltage is given as $V_{IN} = (R1 + R2)/R1$ volts. All other threshold voltages are scaled down accordingly by $\frac{3}{4}$, $\frac{1}{2}$, and $\frac{1}{4}$ the threshold voltage. The current through the LEDs is limited by the output resistors.

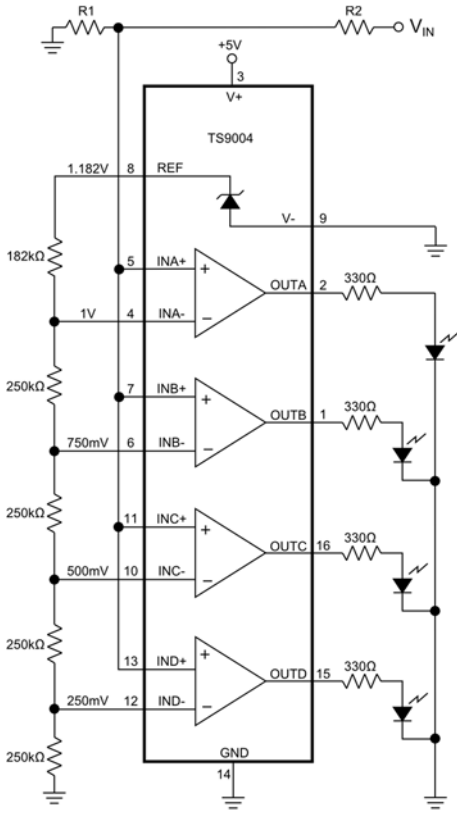

Figure 3. Bar-Graph Level Gauge

Level Shifter

Figure 4 provides a simple way to shift from bipolar $\pm 5V$ inputs to TTL signals by using the TS9004. To protect the comparator inputs, 10k Ω resistors are placed in series and do not have an effect on the performance of the circuit.

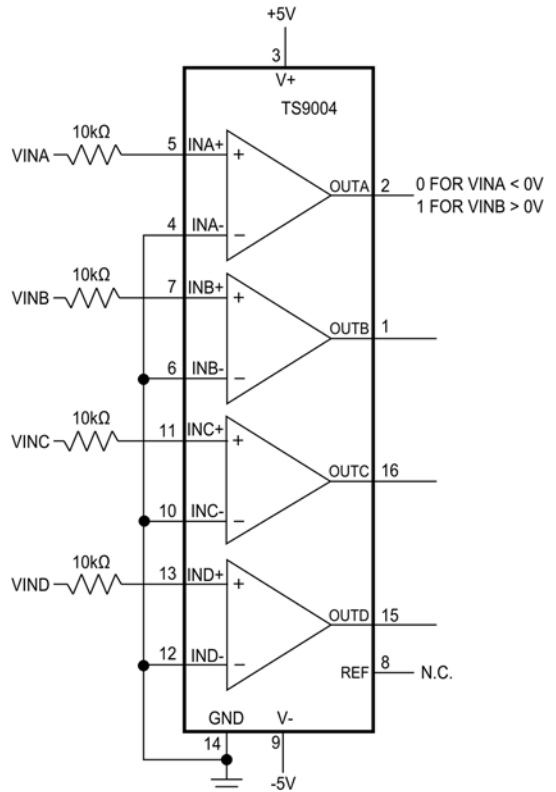
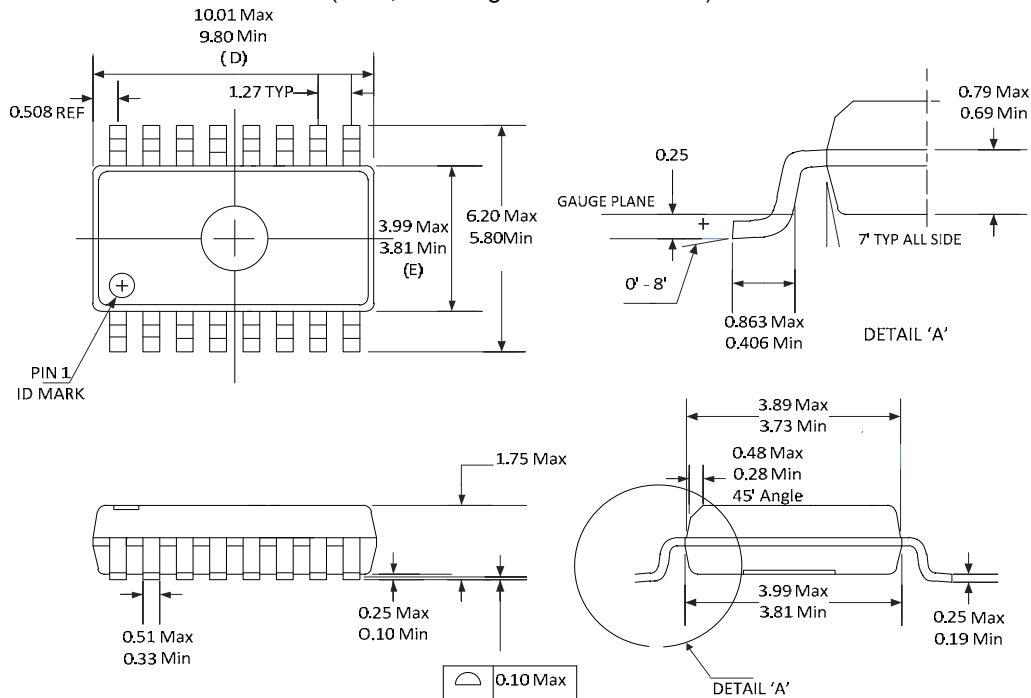

Figure 4. Level Shifter: $\pm 5V$ Input into CMOS output

PACKAGE OUTLINE DRAWING

16-Pin SOIC Package Outline Drawing

(N.B., Drawings are not to scale)



NOTE:

1. "D" DOES NOT INCLUDE MOLD FLASH, PROTRUSIONS OR GATE BURRS. MOLD FLASH, PROTRUSIONS OR GATE BURRS SHALL NOT EXCEED 0.15 mm PER SIDE.
2. "E" DOES NOT INCLUDE INTER-LEAD FLASH OR PROTRUSIONS. INTER-LEAD FLASH AND PROTRUSIONS OR GATE BURRS SHALL NOT EXCEED 0.25 mm PER SIDE.
3. CONTROLLING DIMENSIONS IN MILLIMETERS AND ANGLES IN DEGREES.
4. THIS PART IS COMPLIANT WITH JEDEC SPECIFICATION MS-012 AB
5. LEAD SPAN/STAND OFF HEIGHT/COPLANARITY ARE CONSIDERED AS SPECIAL CHARACTERISTIC.

Patent Notice

Silicon Labs invests in research and development to help our customers differentiate in the market with innovative low-power, small size, analog-intensive mixed-signal solutions. Silicon Labs' extensive patent portfolio is a testament to our unique approach and world-class engineering team.

The information in this document is believed to be accurate in all respects at the time of publication but is subject to change without notice. Silicon Laboratories assumes no responsibility for errors and omissions, and disclaims responsibility for any consequences resulting from the use of information included herein. Additionally, Silicon Laboratories assumes no responsibility for the functioning of undescribed features or parameters. Silicon Laboratories reserves the right to make changes without further notice. Silicon Laboratories makes no warranty, representation or guarantee regarding the suitability of its products for any particular purpose, nor does Silicon Laboratories assume any liability arising out of the application or use of any product or circuit, and specifically disclaims any and all liability, including without limitation consequential or incidental damages. Silicon Laboratories products are not designed, intended, or authorized for use in applications intended to support or sustain life, or for any other application in which the failure of the Silicon Laboratories product could create a situation where personal injury or death may occur. Should Buyer purchase or use Silicon Laboratories products for any such unintended or unauthorized application, Buyer shall indemnify and hold Silicon Laboratories harmless against all claims and damages.

Silicon Laboratories and Silicon Labs are trademarks of Silicon Laboratories Inc. Other products or brandnames mentioned herein are trademarks or registered trademarks of their respective holders.

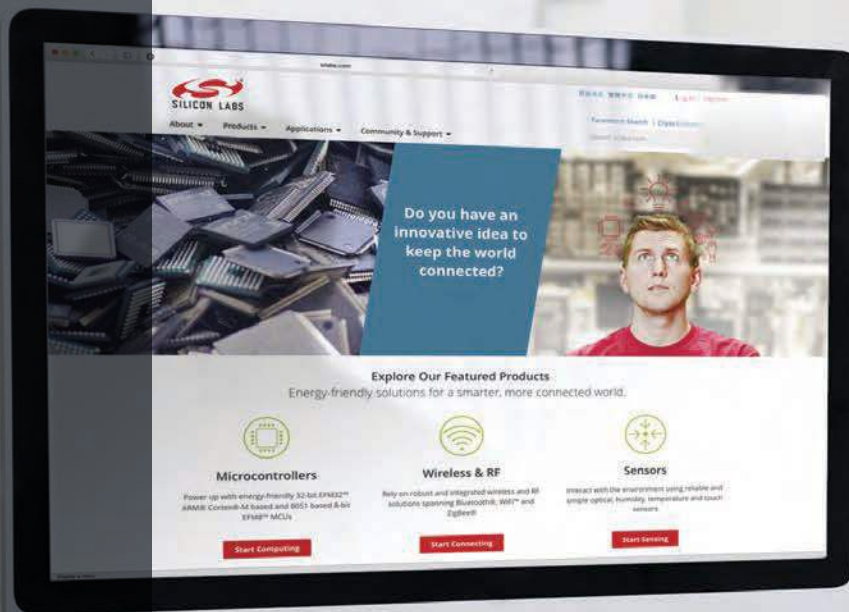

Smart.
Connected.
Energy-Friendly



Products
www.silabs.com/products

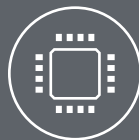

Quality
www.silabs.com/quality



Support and Community
community.silabs.com

Disclaimer

Silicon Laboratories intends to provide customers with the latest, accurate, and in-depth documentation of all peripherals and modules available for system and software implementers using or intending to use the Silicon Laboratories products. Characterization data, available modules and peripherals, memory sizes and memory addresses refer to each specific device, and "Typical" parameters provided can and do vary in different applications. Application examples described herein are for illustrative purposes only. Silicon Laboratories reserves the right to make changes without further notice and limitation to product information, specifications, and descriptions herein, and does not give warranties as to the accuracy or completeness of the included information. Silicon Laboratories shall have no liability for the consequences of use of the information supplied herein. This document does not imply or express copyright licenses granted hereunder to design or fabricate any integrated circuits. The products must not be used within any Life Support System without the specific written consent of Silicon Laboratories. A "Life Support System" is any product or system intended to support or sustain life and/or health, which, if it fails, can be reasonably expected to result in significant personal injury or death. Silicon Laboratories products are generally not intended for military applications. Silicon Laboratories products shall under no circumstances be used in weapons of mass destruction including (but not limited to) nuclear, biological or chemical weapons, or missiles capable of delivering such weapons.

Trademark Information

Silicon Laboratories Inc., Silicon Laboratories, Silicon Labs, SiLabs and the Silicon Labs logo, CMEMS®, EFM, EFM32, EFR, Energy Micro, Energy Micro logo and combinations thereof, "the world's most energy friendly microcontrollers", Ember®, EZLink®, EZMac®, EZRadio®, EZRadioPRO®, DSPLL®, ISOmodem®, Precision32®, ProSLIC®, SiPHY®, USBXpress® and others are trademarks or registered trademarks of Silicon Laboratories Inc. ARM, CORTEX, Cortex-M3 and THUMB are trademarks or registered trademarks of ARM Holdings. Keil is a registered trademark of ARM Limited. All other products or brand names mentioned herein are trademarks of their respective holders.



Silicon Laboratories Inc.
400 West Cesar Chavez
Austin, TX 78701
USA

<http://www.silabs.com>