

Click [here](#) for production status of specific part numbers.

## MAX6765–MAX6774

## Automotive Micropower Linear Regulators with Supervisor

### General Description

The MAX6765–MAX6774B are low-quiescent-current, high-voltage linear regulators that operate from 4V to 72V and deliver up to 100mA of load current. These low-power devices consume only 31 $\mu$ A of quiescent current, making them ideal for always-on automotive modules. These devices are offered with fixed standard output options of 5.0V, 3.3V, 2.5V, and 1.8V, or can be adjusted from 1.8V to 11V with two external resistors.

The MAX6765–MAX6774B feature a push-pull or open-drain, active-low  $\overline{\text{RESET}}$  output with either fixed or adjustable thresholds. Whenever the regulator's output falls below the reset threshold, the  $\overline{\text{RESET}}$  output asserts and remains asserted for at least the minimum reset timeout period after the output voltage exceeds its threshold. The minimum reset timeout period is offered with fixed values from 75 $\mu$ s to 200ms or can be adjusted externally with a small capacitor.

These devices provide three regulator enable modes to accommodate several power-on schemes. The MAX6765/MAX6766/MAX6769/MAX6770/MAX6773/MAX6773B/MAX6774/MAX6774B feature a single traditional enable input (ENABLE) to turn on and off the regulator. The MAX6771/MAX6772 provide dual enable inputs (ENABLE1 and ENABLE2) to turn on and off the regulator either through an ignition switch or a bus transceiver. The MAX6767/MAX6768 provide a hold input (HOLD) in addition to the enable input to allow for the implementation of a self-holding circuit without requiring external components. Setting  $\overline{\text{HOLD}}$  low after enabling the regulator forces the regulator to remain on even if ENABLE is subsequently set low. Releasing  $\overline{\text{HOLD}}$  shuts down the regulator.

The MAX6773/MAX6773B/MAX6774/MAX6774B also include a watchdog input that monitors a pulse train from the microprocessor ( $\mu$ P) and generates a reset pulse if the watchdog input remains high or low for a duration longer than the 1.6s (typ) (MAX6773/MAX6774) or 50ms (typ) (MAX6773B/MAX6774B) watchdog timeout period.

The MAX6765–MAX6774B are available in a small, thermally enhanced 3mm x 3mm TDFN package that can dissipate up to 1.951W, thereby supporting continuous regulator operation during high ambient temperatures, high battery voltage, and high load-current conditions.

The MAX6765–MAX6774B are fully specified for a -40°C to +125°C operating temperature range.

### Applications

- Automotive
- Industrial
- Telecom

**Typical Application Circuit and Selector Guide appear at end of data sheet.**

### Features

- Low 31 $\mu$ A Quiescent Current
- 4V to 72V Wide Input Voltage Range
- 100mA Output Current Capability
- Dropout Voltage of 620mV with 5V Output at 100mA
- Fixed Output-Voltage Options: 5V, 3.3V, 2.5V, and 1.8V
- Watchdog Timer Option (1.6s (MAX6773/MAX6774) and 50ms (MAX6773B/MAX6774B))
- Adjustable Output Voltages from 1.8V to 11V
- Open-Drain or Push-Pull  $\overline{\text{RESET}}$  Output
- Fixed or Capacitor-Adjustable Reset Timeouts
- Small, Thermally Enhanced 1.9W, 3mm x 3mm TDFN Package
- Overtemperature and Short-Circuit Protection
- Fully Specified from -40°C to +125°C
- AEC-Q100 qualified (MAX6765TT\_D\_/\_V+, MAX6767TA\_D\_/\_V+, MAX6769TA\_D\_/\_V+, MAX6773TA\_D\_/\_V+, MAX6773BTA\_D\_/\_V+ only)

### Ordering Information

PART	TEMP RANGE	PIN-PACKAGE
MAX6765TT_D_+	-40°C to +125°C	6 TDFN-EP*
MAX6765TT_D_/_V+	-40°C to +125°C	6 TDFN-EP*

**Ordering Information continued at end of data sheet.**

The first “\_” is a placeholder for the voltage output and reset threshold. The 2nd “\_” designates the fixed reset-timeout option. See Tables 1 and 2 for details. For example, the MAX6765TTLD4 has a 5V output, a reset threshold of 4.65V, and a 200ms typical reset timeout.

+Denotes a lead(Pb)-free/RoHS-compliant package.

\_V denotes an automotive qualified part.

\*EP = Exposed pad.

For tape-and-reel orders add a “T” after the “+” symbol to complete the part number. Tape-and-reel orders are available in 2.5k increments. Nonstandard versions require a 10k minimum order quantity.

### Pin Configurations

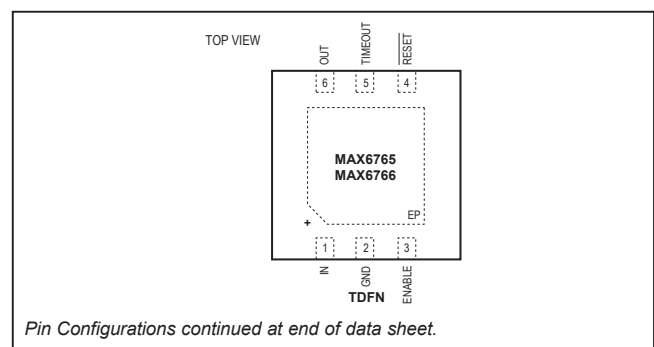

### Absolute Maximum Ratings

(All pins referenced to GND, unless otherwise noted.)

V <sub>IN</sub> .....	-0.3V to +80V
OUT .....	-0.3V to min (12V, IN + 0.3V)
ENABLE, ENABLE1, ENABLE2 .....	-0.3V to (IN + 0.3V)
RESET (open-drain output), TIMEOUT, WDI, RESETIN, SET .....	-0.3V to 12V
RESET (push-pull output), HOLD .....	-0.3V to (OUT + 0.3V)
Maximum Current (all pins except IN and OUT) .....	50mA
Continuous Power Dissipation (T <sub>A</sub> = +70°C) 6-Pin TDFN 3mm x 3mm (derate 23.8mW/°C above +70°C) .....	1904.8mW

8-Pin TDFN 3mm x 3mm (derate 24.4mW/°C above +70°C) .....	1951.2mW
Operating Temperature Range .....	-40°C to +125°C
Junction Temperature .....	+150°C
Storage Temperature Range .....	-65°C to +150°C
Lead Temperature (soldering, 10s) .....	+300°C
Soldering Temperature (reflow) .....	+260°C

Stresses beyond those listed under "Absolute Maximum Ratings" may cause permanent damage to the device. These are stress ratings only, and functional operation of the device at these or any other conditions beyond those indicated in the operational sections of the specifications is not implied. Exposure to absolute maximum rating conditions for extended periods may affect device reliability.

### Package Information

#### TDFN-6

PACKAGE CODE	T633+2
Outline Number	<a href="#">21-0137</a>
Land Pattern Number	<a href="#">90-0058</a>
<b>Thermal Resistance, Single-Layer Board:</b>	
Junction to Ambient (θ <sub>JA</sub> )	55°C/W
Junction to Case (θ <sub>JC</sub> )	9°C/W
<b>Thermal Resistance, Multi-Layer Board:</b>	
Junction to Ambient (θ <sub>JA</sub> )	42°C/W
Junction to Case (θ <sub>JC</sub> )	9°C/W

#### TDFN-8

PACKAGE CODE	T833+2
Outline Number	<a href="#">21-0137</a>
Land Pattern Number	<a href="#">90-0058</a>
<b>Thermal Resistance, Single-Layer Board:</b>	
Junction to Ambient (θ <sub>JA</sub> )	54°C/W
Junction to Case (θ <sub>JC</sub> )	8°C/W
<b>Thermal Resistance, Multi-Layer Board:</b>	
Junction to Ambient (θ <sub>JA</sub> )	41°C/W
Junction to Case (θ <sub>JC</sub> )	8°C/W

For the latest package outline information and land patterns (footprints), go to [www.maximintegrated.com/packages](http://www.maximintegrated.com/packages). Note that a "+", "#", or "-" in the package code indicates RoHS status only. Package drawings may show a different suffix character, but the drawing pertains to the package regardless of RoHS status.

Package thermal resistances were obtained using the method described in JEDEC specification JESD51-7, using a four-layer board. For detailed information on package thermal considerations, refer to [www.maximintegrated.com/thermal-tutorial](http://www.maximintegrated.com/thermal-tutorial).

## Electrical Characteristics

( $V_{IN} = 14V$ ,  $C_{IN} = 0.1\mu F$ ,  $C_{OUT} = 10\mu F$ ,  $T_A = T_J = -40^\circ C$  to  $+125^\circ C$ , unless otherwise noted. Typical values are at  $T_A = T_J = +25^\circ C$ .)  
(Note 1)

PARAMETER	SYMBOL	CONDITIONS	MIN	TYP	MAX	UNITS
Supply Voltage Range	$V_{IN}$		4		72	V
Supply Current (MAX6765–MAX6772) (Note 2)		$I_{LOAD} = 0A$		31	45	$\mu A$
		$I_{LOAD} = 50mA$		35	50	
		$I_{LOAD} = 100mA$ , $V_{IN} = 14V$		37	55	
		$I_{LOAD} = 0A$ , $V_{IN} = 42V$		35	50	
		$I_{LOAD} = 10mA$ , $V_{IN} = 42V$		37	55	
Supply Current (MAX6773/MAX6773B/ MAX6774/MAX6774B) (Note 2)		$I_{LOAD} = 0A$		38	50	$\mu A$
		$I_{LOAD} = 50mA$		42	55	
		$I_{LOAD} = 100mA$		44	60	
		$I_{LOAD} = 0A$ , $V_{IN} = 42V$		42	55	
		$I_{LOAD} = 10mA$ , $V_{IN} = 42V$		44	60	
Shutdown Supply Current	$I_{SHDN}$	ENABLE, ENABLE1, ENABLE2 = GND		3.3	7	$\mu A$
Output Voltage	$V_{OUT}$	L/M, $I_{LOAD} = 1mA$	4.925	5	5.075	V
		L/M, $1mA \leq I_{LOAD} \leq 100mA$ , $V_{IN} = 11V$	4.850	5	5.150	
		T/S, $I_{LOAD} = 1mA$	3.251	3.3	3.350	
		T/S, $1mA \leq I_{LOAD} \leq 100mA$ , $V_{IN} = 9.3V$	3.201	3.3	3.399	
		Z/Y, $I_{LOAD} = 1mA$	2.463	2.5	2.538	
		Z/Y, $1mA \leq I_{LOAD} \leq 100mA$ , $V_{IN} = 8.5V$	2.425	2.5	2.575	
		W/V, $I_{LOAD} = 1mA$	1.773	1.8	1.827	
		W/V, $1mA \leq I_{LOAD} \leq 100mA$ , $V_{IN} = 7.8V$	1.746	1.8	1.854	
Adjustable Output Voltage Range	$V_{OUT}$		1.8		11.0	V
SET Threshold Voltage (MAX6767–MAX6774)	$V_{SET}$	$I_{LOAD} = 1mA$	1.20	1.233	1.26	V
Dual Mode™ SET Threshold		SET rising		116		mV
		SET falling		58		

Dual Mode is a trademark of Maxim Integrated Products, Inc.

## Electrical Characteristics (continued)

( $V_{IN} = 14V$ ,  $C_{IN} = 0.1\mu F$ ,  $C_{OUT} = 10\mu F$ ,  $T_A = T_J = -40^\circ C$  to  $+125^\circ C$ , unless otherwise noted. Typical values are at  $T_A = T_J = +25^\circ C$ .)  
(Note 1)

PARAMETER	SYMBOL	CONDITIONS	MIN	TYP	MAX	UNITS	
SET Input Current (MAX6767–MAX6774)	$I_{SET}$	$V_{SET} = 1.5V$ , $V_{IN} = 11V$	-100		+100	nA	
Dropout Voltage (Note 3)	$\Delta V_{DO}$	L/M, 5V output option, $I_{LOAD} = 10mA$		60	130	mV	
		L/M, 5V output option, $I_{LOAD} = 50mA$		300	630		
		L/M, 5V output option, $I_{LOAD} = 100mA$		620	1200		
		T/S, 3.3V output option, $I_{LOAD} = 100mA$		866	1600		
Guaranteed Output Current (Note 4)			100			mA	
Output Current Limit		Output shorted to GND, $V_{IN} = 14V$	150	250		mA	
Thermal-Shutdown Temperature				160		$^\circ C$	
Thermal-Shutdown Hysteresis				20		$^\circ C$	
Line Regulation		$6.5V \leq V_{IN} \leq 72V$ , $I_{LOAD} = 1mA$			1	%	
Load Regulation (MAX6767–MAX6774)		$I_{OUT} = 1mA$ to $100mA$ , $V_{IN} = V_{OUT(NOM)} + 6V$			1.5	%	
Power-Supply Rejection Ratio	PSRR	$I_{LOAD} = 10mA$ , $f_{IN} = 100Hz$ , $500mV_{P-P}$		70		dB	
Startup Response Time	$t_{START}$	From ENABLE high to OUT, $I_{LOAD} = 100mA$		180		$\mu s$	
Output Overvoltage Protection Threshold	$OV_{TH}$	$I_{SINK} = 1mA$ (from OUT)	$1.07 \times V_{OUT}$	$1.1 \times V_{OUT}$	$1.13 \times V_{OUT}$	V	
Output Overvoltage Protection Maximum Sink Current		$OUT = OUT_{(NOM)} \times 1.15$	5	10		mA	
<b>LOGIC INPUT (ENABLE, ENABLE1, ENABLE2, HOLD)</b>							
Input Low Voltage	$V_{IL}$	ENABLE, ENABLE1, ENABLE2			0.4	V	
Input High Voltage	$V_{IH}$	ENABLE, ENABLE1, ENABLE2	1.4			V	
ENABLE, ENABLE1, ENABLE2 Input Pulldown Current		ENABLE, ENABLE1, ENABLE2 are internally pulled down to GND		0.6		$\mu A$	
$\overline{HOLD}$ Input Threshold Voltage	$V_{IL}$	$1.8V \leq V_{OUT} \leq 11V$			0.4	V	
	$V_{IH}$	$1.8V \leq V_{OUT} \leq 11V$	OUT - 0.4				
$\overline{HOLD}$ Input Pullup Current		$\overline{HOLD}$ is internally pulled up to OUT		1.8		$\mu A$	
<b>RESET OUTPUT</b>							
$\overline{RESET}$ Threshold		SET = GND, $\overline{RESET}$ falling	L	4.500	4.625	4.750	V
			M	4.250	4.375	4.500	
			T	2.970	3.053	3.135	
			S	2.805	2.888	2.970	
			Z	2.250	2.313	2.375	
			Y	2.125	2.188	2.250	
			W	1.620	1.665	1.710	
			V	1.530	1.575	1.620	

## Electrical Characteristics (continued)

( $V_{IN} = 14V$ ,  $C_{IN} = 0.1\mu F$ ,  $C_{OUT} = 10\mu F$ ,  $T_A = T_J = -40^\circ C$  to  $+125^\circ C$ , unless otherwise noted. Typical values are at  $T_A = T_J = +25^\circ C$ .)  
(Note 1)

PARAMETER	SYMBOL	CONDITIONS	MIN	TYP	MAX	UNITS	
RESE $\overline{T}$ Threshold (Adjustable Output Voltage)		L/T/Z/W, SET = resistive divider, RESE $\overline{T}$ falling	$V_{OUT} \times 0.9$	$V_{OUT} \times 0.925$	$V_{OUT} \times 0.950$	V	
		M/S/Y/V, SET = resistive divider, RESE $\overline{T}$ falling	$V_{OUT} \times 0.85$	$V_{OUT} \times 0.875$	$V_{OUT} \times 0.900$		
RESE $\overline{TIN}$ Input Current		$V_{RESE\overline{TIN}} = V_{GND} or 12V$	-100		+100	nA	
RESE $\overline{TIN}$ Threshold		$V_{TH} = 87.5\%$ of $V_{SET}$ (M/S/Y/V), RESE $\overline{T}$ falling	1.057	1.085	1.112	V	
		$V_{TH} = 92.5\%$ of $V_{SET}$ (L/T/Z/W), RESE $\overline{T}$ falling	1.118	1.147	1.176		
OUT to RESE $\overline{T}$ Delay		$V_{OUT}$ falling		0.3		$\mu s$	
RESE $\overline{TIN}$ To RESE $\overline{T}$ Delay		RESE $\overline{TIN}$ falling		35		$\mu s$	
RESE $\overline{T}$ Timeout Period (TIMEOUT Connected to OUT)		$V_{OUT}$ rising	D0		75	ms	
			D1	2.187	3.125		4.063
			D2	8.75	12.5		16.25
			D3	35	50		65
			D4	140	200		260
TIMEOUT Ramp Current			800	1000	1200	nA	
TIMEOUT Ramp Threshold		L/M/T/S options	1.160	1.220	1.259	V	
		V/W/Y/Z options	1.060	1.170	1.242		
RESE $\overline{T}$ Output-Voltage Low (Open Drain or Push-Pull)	$V_{OL}$	$V_{OUT} \geq 1.8V$ , $I_{SINK} = 50\mu A$ , RESE $\overline{T}$ asserted			0.3	V	
		$V_{OUT} \geq 1.8V$ , $I_{SINK} = 3.2mA$ , RESE $\overline{T}$ asserted			0.4		
RESE $\overline{T}$ Output-Voltage High (Push-Pull)	$V_{OH}$	$V_{OUT} \geq 1.8V$ , $I_{SOURCE} = 250\mu A$ , RESE $\overline{T}$ not asserted	$0.8 \times V_{OUT}$			V	
RESE $\overline{T}$ Open-Drain Leakage Current		RESE $\overline{T}$ not asserted, RESE $\overline{T} = 12V$			100	nA	
Watchdog Minimum Input Pulse	$t_{WDI}$	$1.8V \leq V_{OUT} \leq 11V$	1			$\mu s$	
Watchdog Input Low Voltage	$V_{IL}$	$1.8V \leq V_{OUT} \leq 11V$			0.4	V	
Watchdog Input High Voltage	$V_{IH}$	$1.8V \leq V_{OUT} \leq 11V$	$V_{OUT} - 0.4V$			V	
Watchdog Input Low Voltage	$V_{IL}$	$1.8V \leq V_{OUT} \leq 11V$			0.4	V	
Watchdog Input Current	$I_{WDI}$	$V_{WDI} = 0V$ or $V_{WDI} = 12V$	-1		+1	$\mu A$	
Watchdog Timeout Period	$t_{WD}$	MAX6773/MAX6774	1.12	1.6	2.08	s	
		MAX6773B/MAX6774B	40	50	60	ms	

**Note 1:** Production tested at  $T_A = +25^\circ C$ . Overtemperature limits are guaranteed by design.

**Note 2:** Device tested at internally set voltage.

**Note 3:** Dropout voltage for L/M versions is defined as ( $V_{IN} - V_{OUT}$ ) when  $V_{OUT}$  equals 98% of the nominal value of  $V_{OUT}$  when  $V_{IN} = 11V$ . For T/S versions, dropout voltage is defined as ( $V_{IN} - V_{OUT}$ ) when  $V_{OUT}$  equals 98% of the nominal value of  $V_{OUT}$  when  $V_{IN} = 9.3V$ .

**Note 4:** Observe the absolute maximum power dissipation limits.

Typical Operating Characteristics

( $V_{IN} = 14V$ ,  $C_{OUT} = 10\mu F$ ,  $C_{IN} = 0.1\mu F$ ,  $T_A = +25^\circ C$ , unless otherwise noted.)

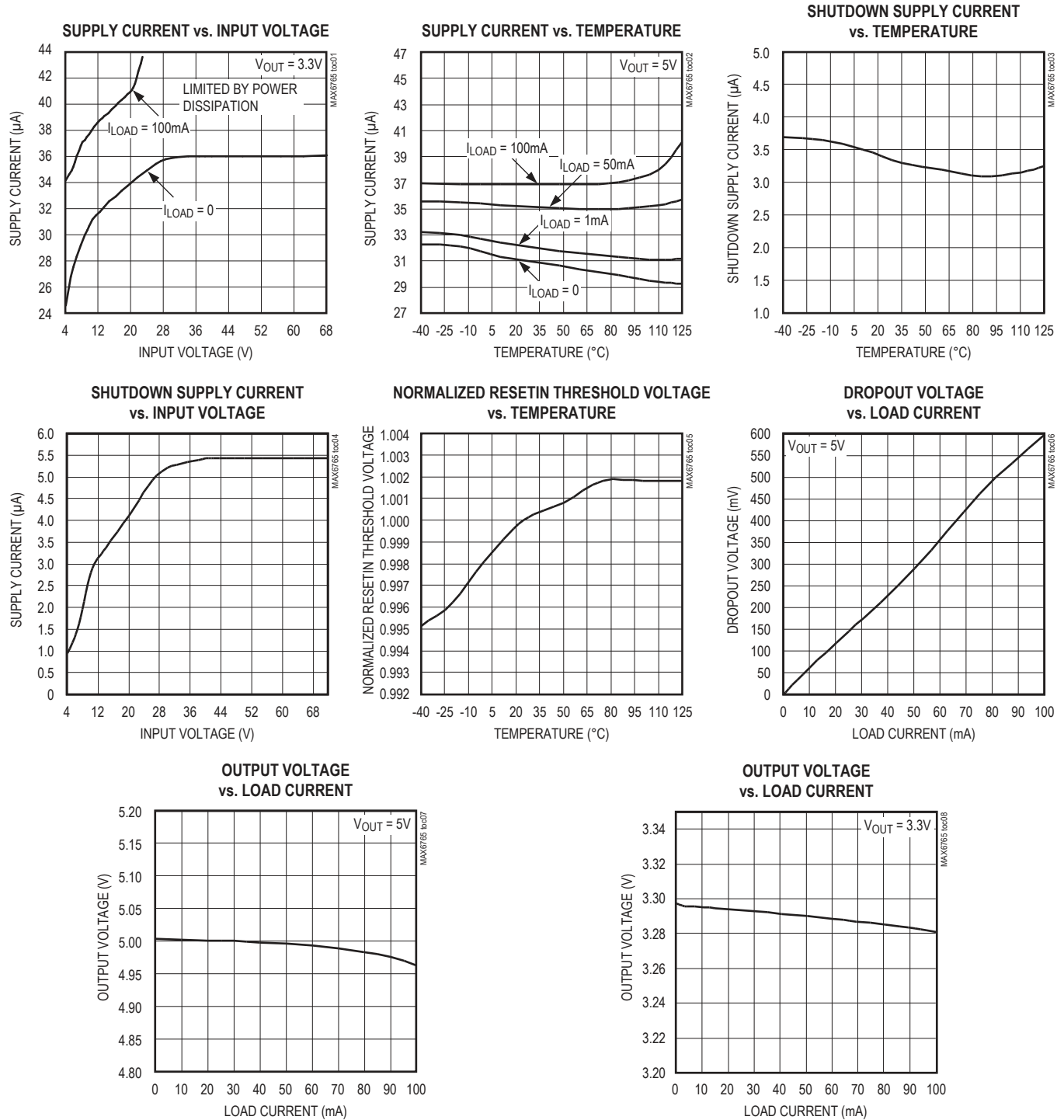

Typical Operating Characteristics (continued)

( $V_{IN} = 14V$ ,  $C_{OUT} = 10\mu F$ ,  $C_{IN} = 0.1\mu F$ ,  $T_A = +25^\circ C$ , unless otherwise noted.)

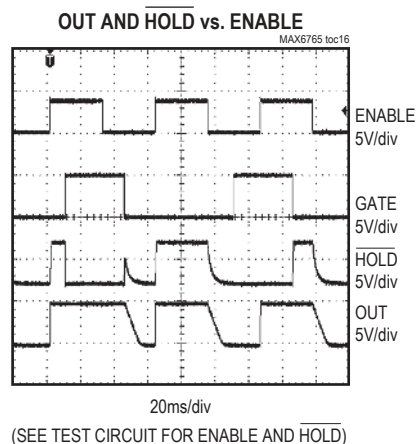
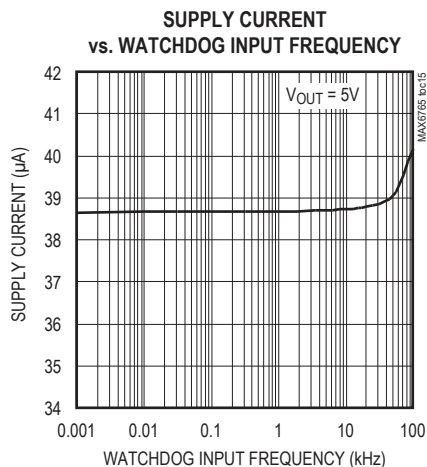
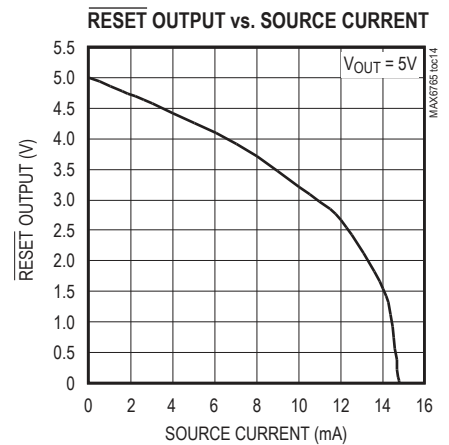
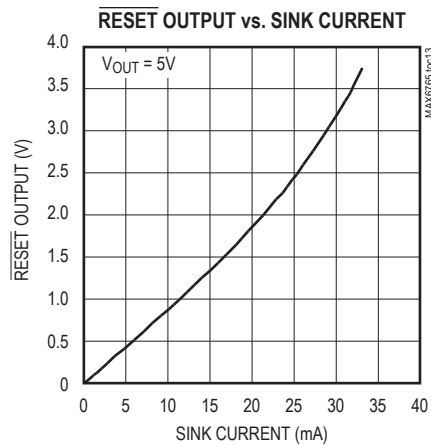
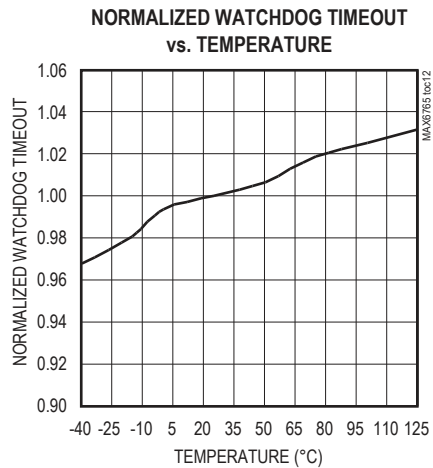
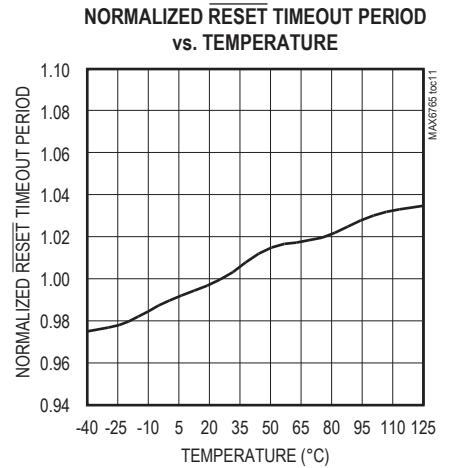
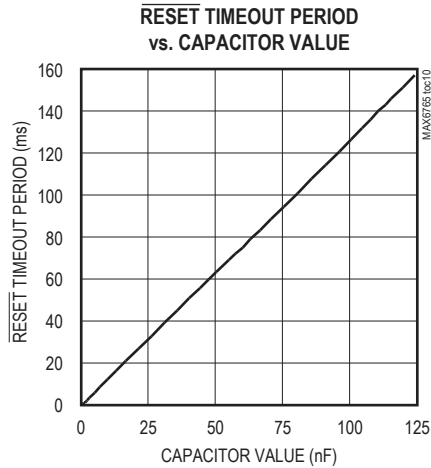
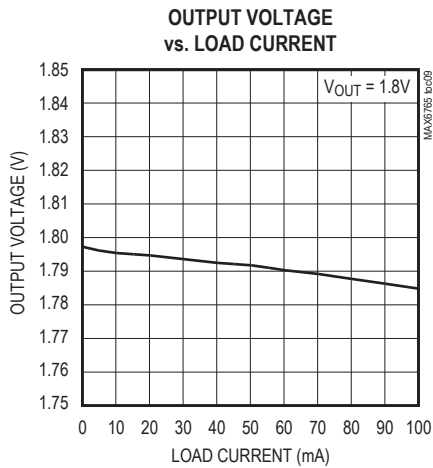

Typical Operating Characteristics (continued)

( $V_{IN} = 14V$ ,  $C_{OUT} = 10\mu F$ ,  $C_{IN} = 0.1\mu F$ ,  $T_A = +25^\circ C$ , unless otherwise noted.)

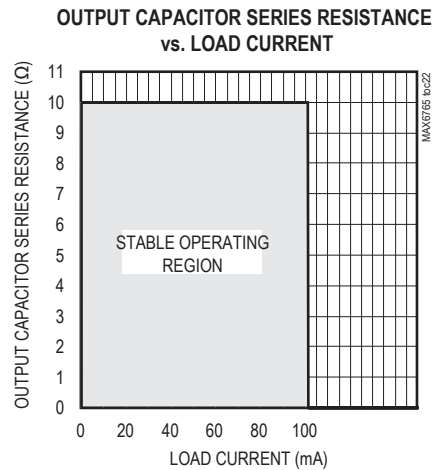
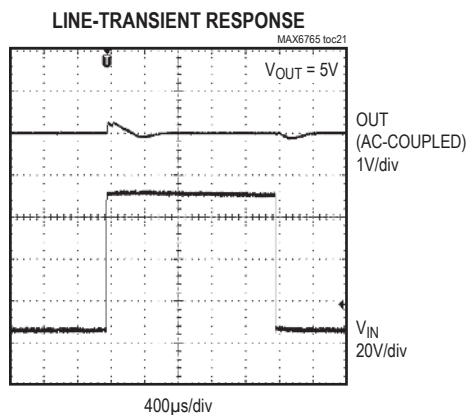
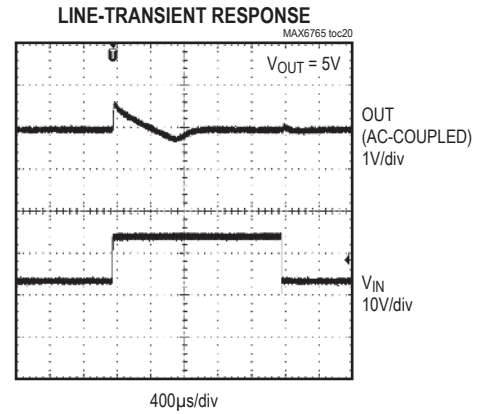
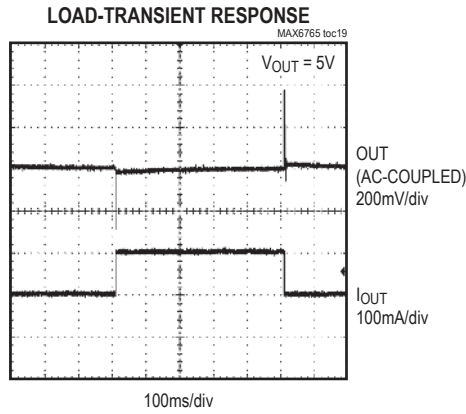
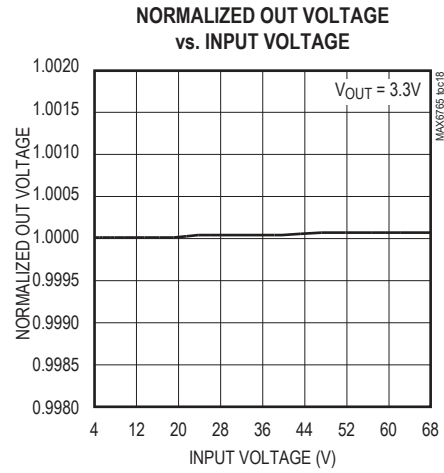
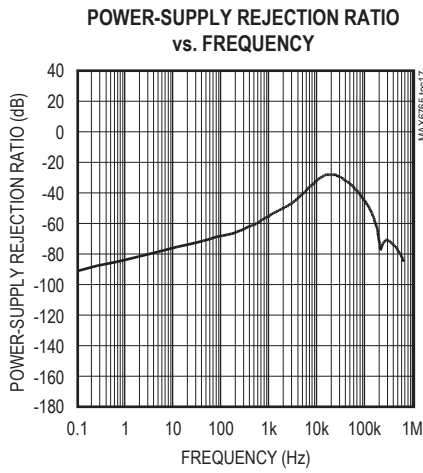



Enable and Hold Test Circuit

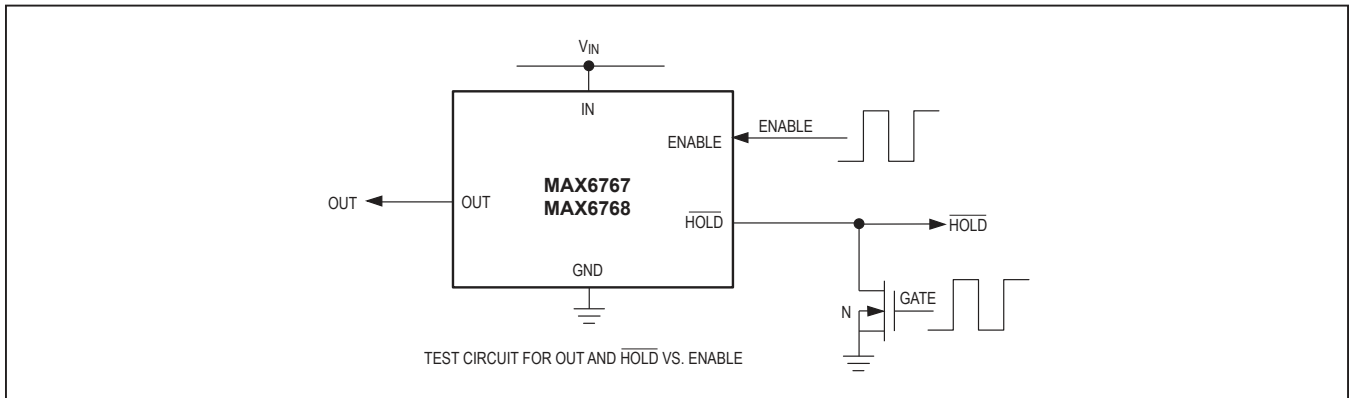

Pin Description

PIN					NAME	FUNCTION
MAX6765/ MAX6766	MAX6767/ MAX6768	MAX6769/ MAX6770	MAX6771/ MAX6772	MAX6773/ MAX6773B/ MAX6774/ MAX6774B		
1	1	1	1	1	IN	Regulator Input. Bypass IN to GND with a capacitor with a minimum value of 0.1µF.
2	2	2	2	2	GND	Ground
3	3	3	—	3	ENABLE	Active-High Enable Input. Drive ENABLE high to turn on the regulator. ENABLE is internally connected to GND through a 0.6µA current sink.
4	5	5	5	5	$\overline{\text{RESET}}$	Active-Low, Open-Drain/Push-Pull Reset Output. For the MAX6769/MAX6770, $\overline{\text{RESET}}$ asserts when RESETIN is below the internal $V_{TH}$ and deasserts when RESETIN is above the internal $V_{TH}$ threshold. For all other versions, $\overline{\text{RESET}}$ remains low while OUT is below the reset threshold. For all versions, $\overline{\text{RESET}}$ remains low for the duration of the reset timeout period after the reset conditions end.
5	7	7	7	7	TIMEOUT	Reset Timeout Adjust Input. Connect TIMEOUT to OUT for the internally fixed timeout period. For an adjustable timeout, connect a capacitor from TIMEOUT to GND. See the <i>Selecting Timeout Capacitor</i> section.
6	8	8	8	8	OUT	Regulator Output. The MAX6765/MAX6766 provide a fixed output (+1.8V, +2.5V, +3.3V, or +5V). The MAX6767–MAX6774 provide a fixed output voltage of +1.8V, +2.5V, +3.3V, or 5V, or adjust the output from +1.8V to +11V. Bypass to GND with a 10µF capacitor (min).

## Pin Description (continued)

PIN					NAME	FUNCTION
MAX6765/ MAX6766	MAX6767/ MAX6768	MAX6769/ MAX6770	MAX6771/ MAX6772	MAX6773/ MAX6773B/ MAX6774/ MAX6774B		
—	4	—	—	—	HOLD	Active-Low Regulator Hold Input. When $\overline{\text{HOLD}}$ is forced low, OUT remains on even if ENABLE is pulled low. To shut down the regulator, release $\overline{\text{HOLD}}$ after ENABLE is pulled low. Connect $\overline{\text{HOLD}}$ to OUT or leave unconnected if unused. $\overline{\text{HOLD}}$ is internally connected to OUT through a 1.8 $\mu\text{A}$ current source.
—	6	6	6	6	SET	Feedback Input for Setting the Output Voltage. Connect SET to GND to select the preset output voltage. Connect to an external resistive divider for adjustable output operation.
—	—	4	—	—	RESETIN	Adjustable Reset Threshold Input. Connect to a resistive divider to set the desired threshold.
—	—	—	3	—	ENABLE1	Active-High Enable Input 1. Drive ENABLE1 high to turn on the regulator. ENABLE1 is internally connected to ground through a 0.6 $\mu\text{A}$ current sink.
—	—	—	4	—	ENABLE2	Active-High Enable Input 2. Drive ENABLE2 high to turn on the regulator. ENABLE2 is internally connected to ground through a 0.6 $\mu\text{A}$ current sink.
—	—	—	—	4	WDI	Watchdog Timer Input. If WDI remains high or low for longer than the watchdog timeout period, the internal watchdog timer expires and the reset output asserts for the reset timeout period. The internal watchdog timer clears whenever a reset is asserted or WDI sees a rising or falling edge. The watchdog timer cannot be disabled. Do not leave WDI unconnected.
—	—	—	—	—	EP	Exposed Pad. EP is internally connected to GND. Connect EP to the ground plane to provide a low thermal-resistance path from the IC junction to the PCB. Do not use as the electrical connection to GND.

## Detailed Description

The MAX6765–MAX6774B low-quiescent-current, high-voltage linear regulators operate from a 4V to 72V input voltage and deliver more than 100mA of load current. The MAX6765–MAX6774B include an integrated  $\mu\text{P}$  reset circuit that monitors the regulator output voltage and asserts a reset output when OUT falls below a threshold limit, and includes an internally fixed or adjustable reset timeout using a capacitor from TIME-OUT to ground. All devices are available in a preset output-voltage option of +1.8V, +2.5V, +3.3V, and +5V.

The output voltage of the MAX6767–MAX6774B is adjustable from +1.8V to +11V using a resistive divider at SET. The MAX6773/MAX6774 include a watchdog timer (WDI) with a 1.6s (typ) watchdog timeout period and the MAX6773B/MAX6774B include a watchdog timer with a 50ms (typ) watchdog timeout period. The MAX6769/MAX6770 feature an adjustable reset threshold using a resistive divider between the monitored voltage, RESETIN, and GND; see the *Functional Diagrams*.

The MAX6771/MAX6772 provide dual enable inputs (ENABLE1 and ENABLE2) to turn on and off the regulator either through an ignition switch or a bus transceiver.

Functional Diagrams

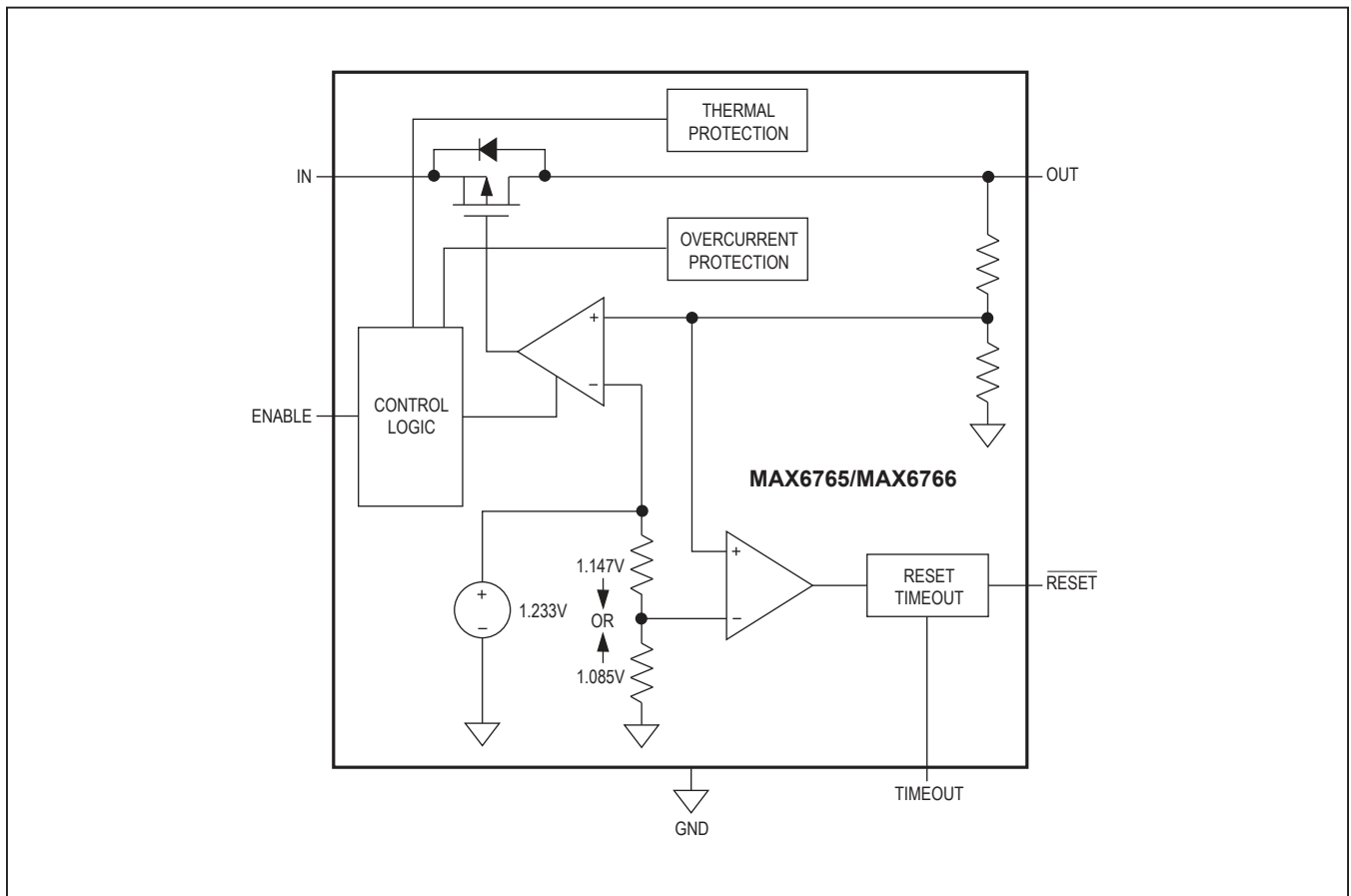

Functional Diagrams (continued)

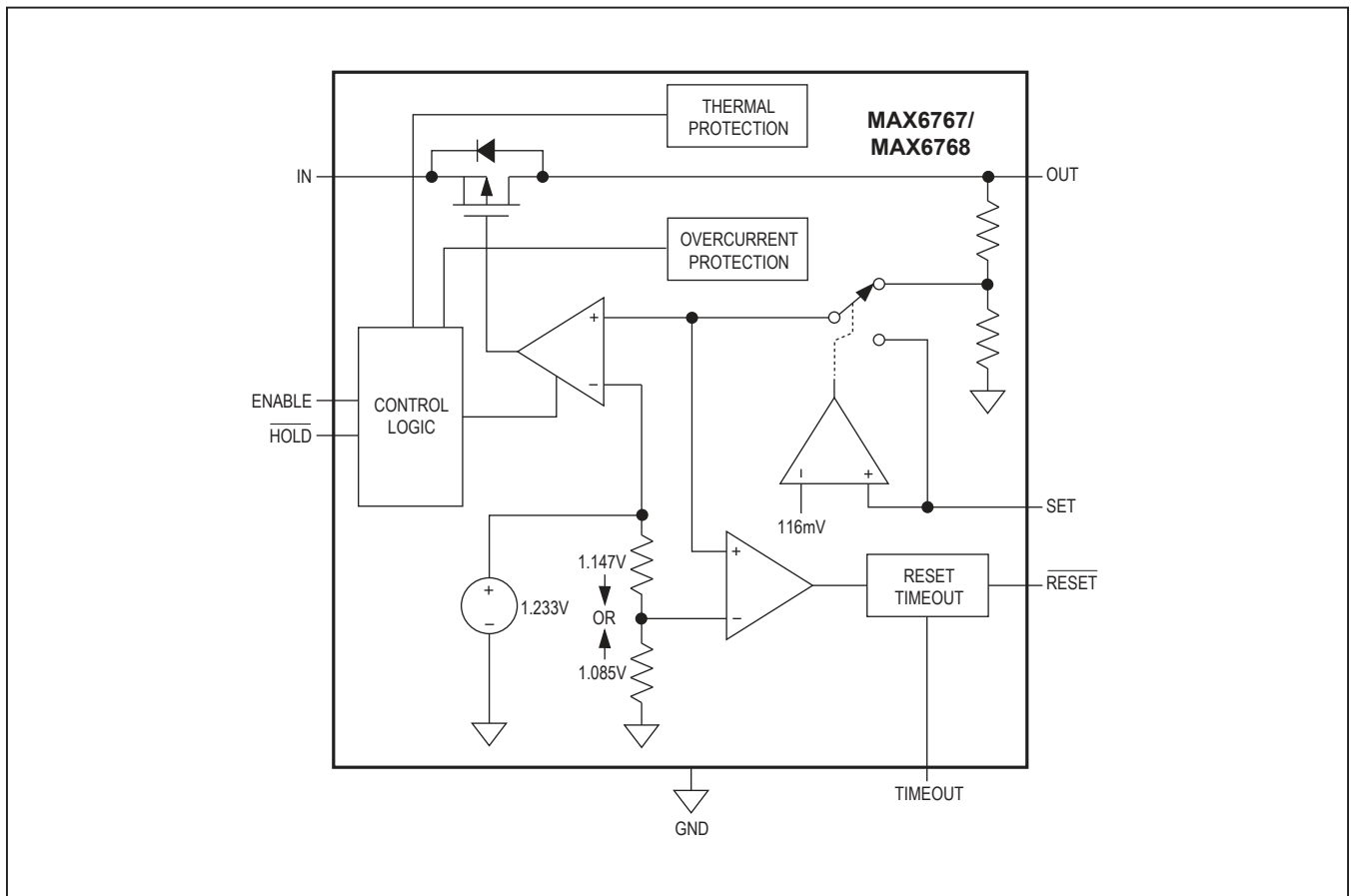

Functional Diagrams (continued)

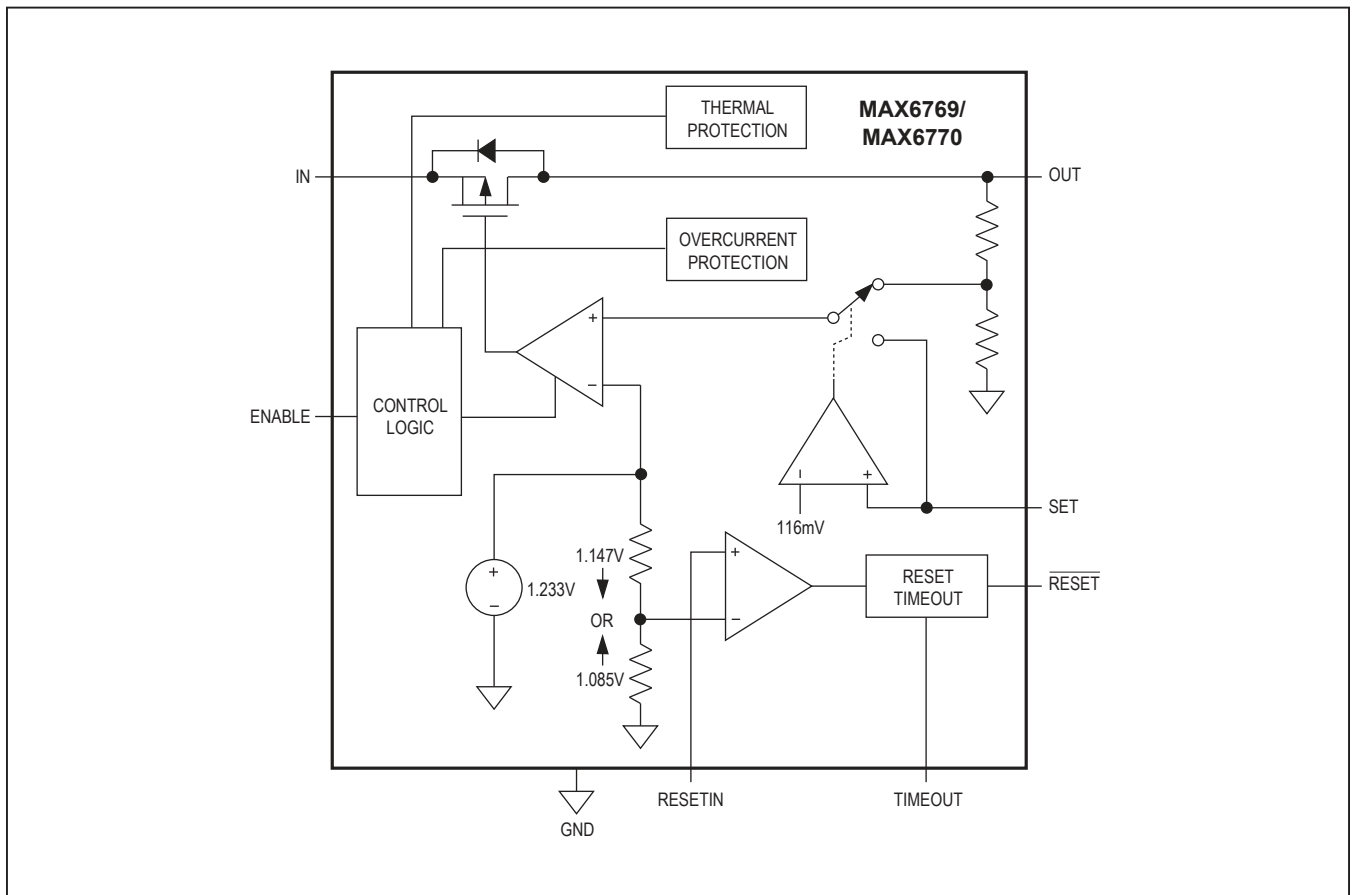

Functional Diagrams (continued)

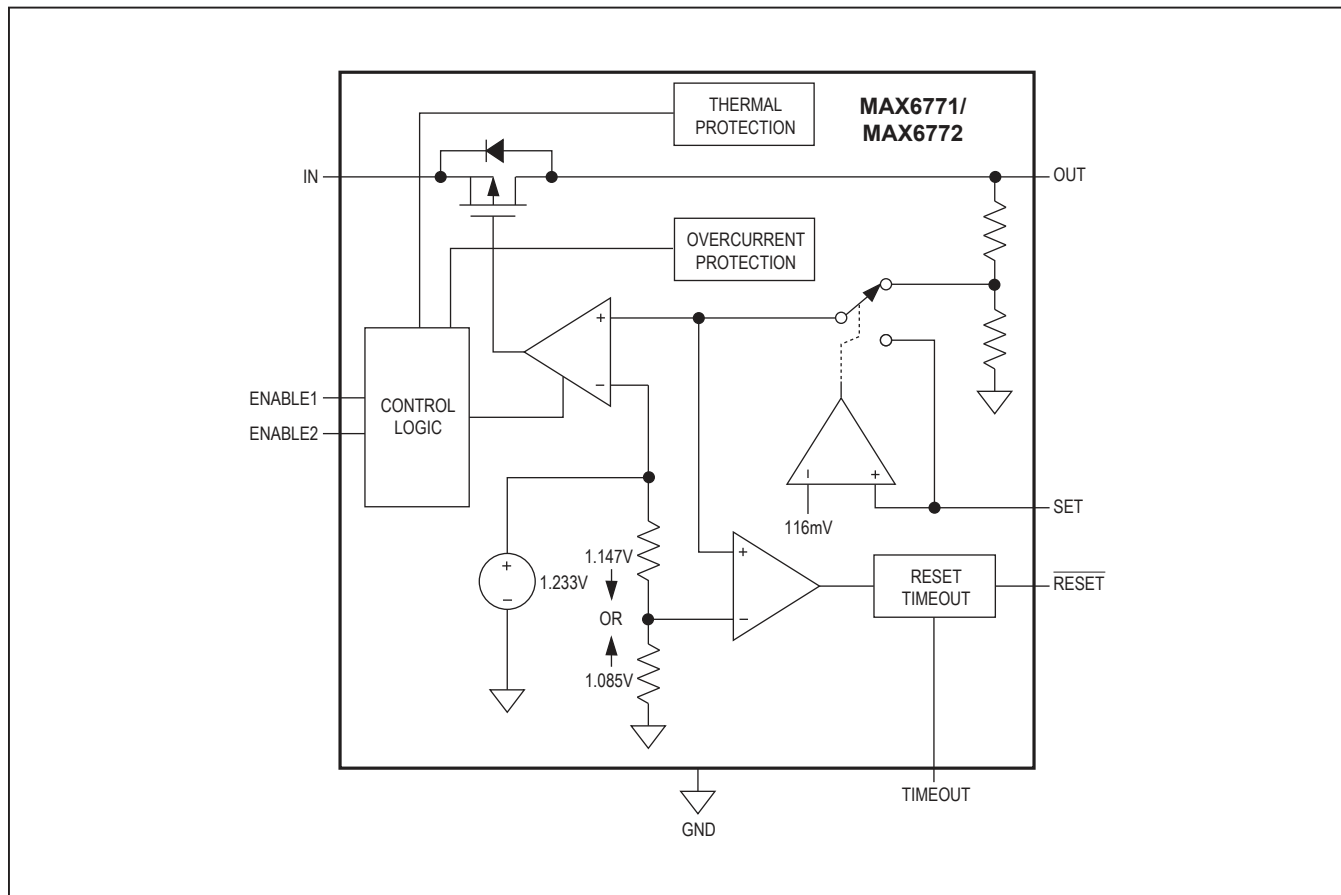

Functional Diagrams (continued)

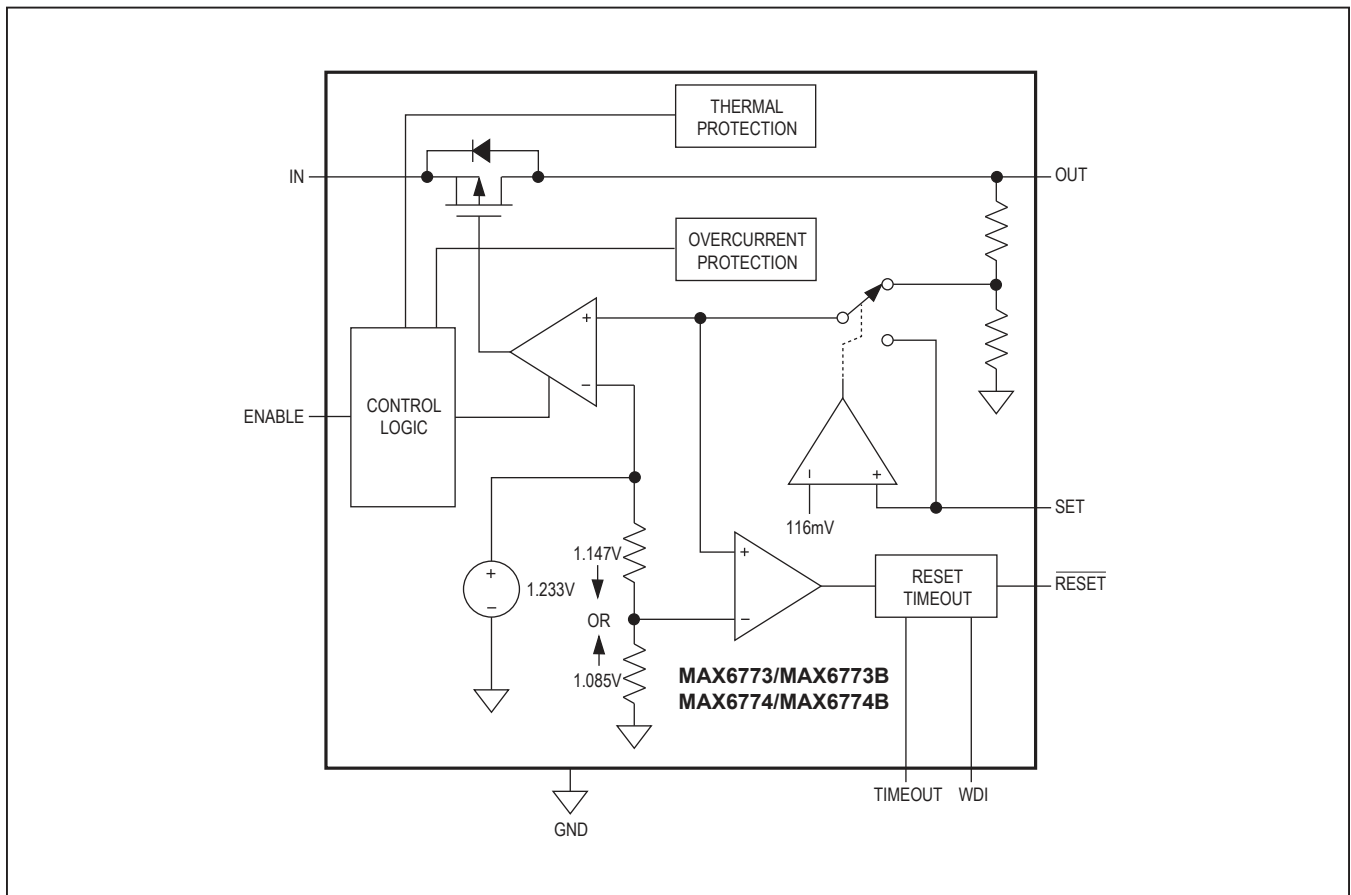

**Regulator**

The regulator accepts an input voltage from +4V to +72V. All of the devices feature fixed output-voltage options of +1.8V, +2.5V, +3.3V, and +5V. The MAX6767–MAX6774B feature an adjustable output voltage set with an external resistive-divider network connected between OUT, SET, and GND. See Figure 1.

**Enable and Hold Inputs (MAX6767/MAX6768)**

The MAX6767/MAX6768 support two logic inputs, ENABLE (active-high) and  $\overline{\text{HOLD}}$  (active-low), making these devices “automotive friendly.” For example, when the ignition key signal drives ENABLE high, the regulator turns on and remains on even if ENABLE goes low, as long as  $\overline{\text{HOLD}}$  is forced low and kept low before ENABLE goes low. In this state, releasing  $\overline{\text{HOLD}}$  turns the regulator output (OUT) off. This feature makes it possible to implement a self-holding circuit without external components. Forcing ENABLE low with  $\overline{\text{HOLD}}$  high (or unconnected) places the MAX6767/MAX6768 into shutdown mode, drawing 3.3µA (typ) of supply current.

Table 3 shows the state of the regulator output with respect to the voltage level at ENABLE and  $\overline{\text{HOLD}}$ . Connect  $\overline{\text{HOLD}}$  to OUT or leave it unconnected to allow the ENABLE input to act as a standard enable/shutdown switch for the regulator output (OUT).

**Reset Output**

The reset output is typically connected to the reset input of a µP. A µP’s reset input starts or restarts the µP in a known state. The MAX6765–MAX6774B supervisory circuits provide the reset logic to prevent code-execution errors during power-up, power-down, and brownout conditions (see the *Typical Application Circuit*). RESET changes from high to low whenever the monitored voltage drops below the reset threshold voltages. Once the

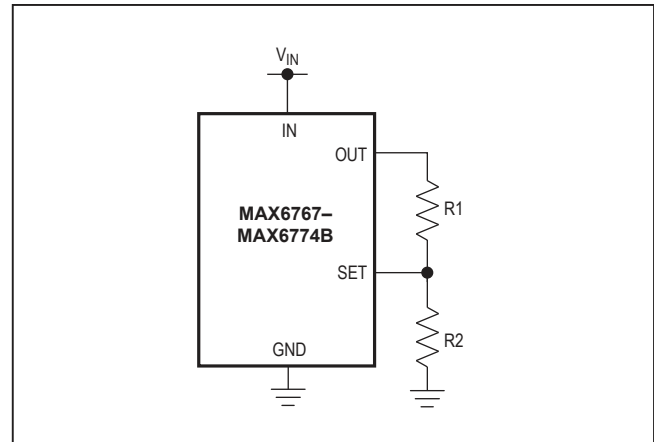

Figure 1. Setting the Output Voltage Using a Resistive Divider

monitored voltage exceeds its respective reset threshold voltage(s), RESET remains low for the reset timeout period, then goes high. See Table 1 and Table 2.

**Table 1. Preset Timeout Period**

PART NUMBER SUFFIX ( )	TIMEOUT PERIOD
D0	75µs
D1	3.125ms
D2	12.5ms
D3	50ms
D4	200ms

**RESETIN Threshold (MAX6769/MAX6770)**

The MAX6769/MAX6770 monitor the voltage on RESETIN using an adjustable reset threshold ( $V_{\text{RESETIN}}$ ) set with an external resistive voltage-divider and the internal reset threshold ( $V_{\text{TH}}$ ). See Table 2.

**Table 2. Preset Output Voltage and Reset Threshold**

PART SUFFIX ( )	OUTPUT VOLTAGE (V)	RESET THRESHOLD (V) (ALL VERSIONS EXCEPT MAX6769/MAX6770)	RESETIN THRESHOLD (V) (MAX6769/MAX6770 ONLY)
L	5	4.625	1.147
M	5	4.375	1.085
T	3.3	3.353	1.147
S	3.3	2.888	1.085
Z	2.5	2.313	1.147
Y	2.5	2.188	1.085
W	1.8	1.665	1.147
V	1.8	1.575	1.085



**Table 3. ENABLE/ $\overline{\text{HOLD}}$  Truth Table/State Table**

OPERATING STATE	ENABLE	$\overline{\text{HOLD}}$	REGULATOR OUTPUT	COMMENT
Initial State	Low	Don't care	Off	ENABLE is pulled to GND through an internal pulldown. $\overline{\text{HOLD}}$ is high impedance (pulled up to OUT). Regulator output is disabled.
Turn-On State	High	Don't care	On	ENABLE is externally driven high turning the regulator output on. $\overline{\text{HOLD}}$ is pulled up by OUT.
Hold Setup State	High	Low	On	$\overline{\text{HOLD}}$ is externally pulled low while ENABLE remains high (latches $\overline{\text{HOLD}}$ state).
Hold State	Low	Low	On	ENABLE is driven low (or pulled low by an internal pulldown). $\overline{\text{HOLD}}$ remains externally pulled low keeping the regulator output on.
Off-State	Low	High (pulled high)	Off	$\overline{\text{HOLD}}$ is driven high (or pulled high by an internal pullup) while ENABLE is low. Regulator output is shut off and ENABLE/ $\overline{\text{HOLD}}$ logic returns to the initial state.

### Watchdog Timer (MAX6773/MAX6773B/ MAX6774/MAX6774B)

The MAX6773/MAX6774 include a watchdog timer that asserts  $\overline{\text{RESET}}$  if the watchdog input (WDI) does not toggle within the watchdog timeout period,  $t_{\text{WD}}$  (1.6s (typ) for the MAX6773/MAX6774 and 50ms (typ) for the MAX6773B/MAX6774B).  $\overline{\text{RESET}}$  remains low for the reset timeout period,  $t_{\text{RP}}$ . If the watchdog is not updated for lengthy periods of time, the reset output appears as a pulse train, asserted for the reset timeout period and deasserted for the watchdog timeout period, until WDI is toggled again. When  $\overline{\text{RESET}}$  asserts, it stays low for the entire reset timeout period ignoring any WDI transitions. To prevent the watchdog from asserting  $\overline{\text{RESET}}$ , toggle WDI with a valid rising or falling edge prior to  $t_{\text{WD}}$  (min). The watchdog counter clears when WDI toggles prior to  $t_{\text{WD}}$  or when  $\overline{\text{RESET}}$  asserts. The watchdog resumes counting after  $\overline{\text{RESET}}$  deasserts. The watchdog timer cannot be disabled.

### Thermal Protection

When the junction temperature exceeds  $T_J = +160^\circ\text{C}$  (typ), an internal thermal sensor signals the shutdown logic that turns off the pass transistor and allows the IC to cool. The thermal sensor turns the pass transistor on again after the IC's junction temperature cools by  $20^\circ\text{C}$  (typ), resulting in a cycled output during continuous thermal-overload conditions. Thermal protection protects the MAX6765–MAX6774B in the event of a fault condition. Never exceed the absolute maximum junction temperature rating of  $T_J = +150^\circ\text{C}$ . See Figures 3 and 4 for the safe operating area.

## Applications Information

### Output-Voltage Selection

The MAX6767–MAX6774B feature dual-mode operation and operate in either a preset or adjustable

voltage mode. In preset voltage mode, internal trimmed feedback resistors set the internal linear regulator to +1.8V, +2.5V, +3.3V, or +5V (see Table 2). Select preset-voltage mode by connecting SET to ground. In adjustable mode, select an output voltage between +1.8V and +11V using two external resistors connected as a voltage-divider to SET (see Figure 1). Set the output voltage using the following equation:

$$V_{\text{OUT}} = V_{\text{SET}} (1 + R1/R2)$$

where  $V_{\text{SET}} = 1.233\text{V}$  and the recommended value for R2 is 50k $\Omega$  (maximum 100k $\Omega$ ).

### RESETIN Threshold Selection

The MAX6769/MAX6770 feature an adjustable reset threshold to monitor the voltage on RESETIN using a resistive divider between the monitored voltage, RESETIN and GND. See Figure 2. Use the following formula to set the desired reset threshold:

$$V_{\text{MON}} = V_{\text{TH}} (1 + R3/R4)$$

where  $V_{\text{TH}}$  is 1.085V for the M/S/Y/V versions and 1.147V for the L/T/Z/W versions.

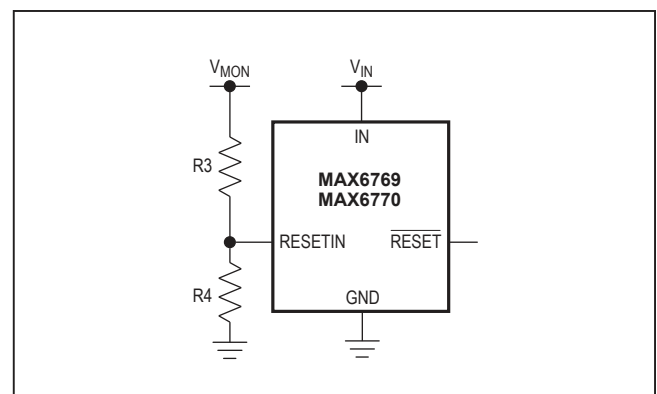

Figure 2. RESETIN Threshold Selection

**Available Output-Current Calculation**

The MAX6765–MAX6774B provide up to 100mA of load current. Package power dissipation limits the amount of output current available for a given input/output voltage and ambient temperature. Figures 3 and 4 depict the maximum power dissipation curve for the MAX6765/MAX6766 and MAX6767–MAX6774B, respectively. The graph assumes that the exposed metal pad of the device package is soldered to a solid 1in<sup>2</sup> section of 2oz. PCB copper (JESD51-3 AND JESD51-5). Use Figure 4 to determine the allowable package dissipation for a given ambient temperature. Alternately, use the following formula to calculate the allowable package dissipation:

$PD_{MAX} = \text{Max. Power Dissip} = 1.951\text{W}$ , for  $T_A \leq +70^\circ\text{C}$

$$PD_{MAX} = \text{Max. Power Dissip} = [1.9\text{W} - 0.0244\text{W} \times (T_A - 70^\circ\text{C})], \text{ for } +70^\circ\text{C} < T_A \leq +125^\circ\text{C}$$

where 0.0244W is the MAX6767–MAX6774B package thermal derating in W/°C and  $T_A$  is the ambient temperature in °C, under the same conditions used for Figure 4.

After determining the allowable package dissipation, calculate the maximum output current using the following formula:

$$PD < PD_{MAX} \text{ where } PD = [(V_{IN} - V_{OUT}) \times I_{OUT}]$$

Also,  $I_{OUT}$  should be  $\leq 100\text{mA}$  in any case.

**Selecting Timeout Capacitor**

The reset timeout period is adjustable to accommodate a variety of  $\mu\text{P}$  applications. Adjust the reset timeout period by connecting a capacitor between TIMEOUT and GND.

$$t_{RP} = C_{TIMEOUT} \times 1.22 \times 10^6\Omega \text{ (L/M/T/S options)}$$

$$t_{RP} = C_{TIMEOUT} \times 1.17 \times 10^6\Omega \text{ (V/W/Y/Z options)}$$

where  $t_{RP}$  is in seconds and  $C_{TIMEOUT}$  is in Farads.

Connect TIMEOUT to OUT to select the internally fixed timeout period.  $C_{TIMEOUT}$  must be a low-leakage ( $< 10\text{nA}$ ) type capacitor. Ceramic capacitors are recommended; do not use capacitor values lower than 100pF to avoid the influence of parasitic capacitances.

**Capacitor Selection and Regulator Stability**

For stable operation over the full temperature range and with load currents up to 100mA, use a 10 $\mu\text{F}$  (min) output capacitor with an ESR  $< 0.5\Omega$ . To reduce noise and improve load-transient response, stability, and power-supply rejection, use larger output-capacitor values. Some ceramic dielectrics exhibit large capacitance and ESR variation with temperature. For dielectric capacitors such as Z5U and Y5V, use more capacitance to ensure stability at low temperatures. With X7R or X5R dielectrics, 10 $\mu\text{F}$  should be sufficient at all operating temperatures. For higher-ESR tantalum capacitors, use larger capacitor values to maintain stability. To improve power-supply rejection and transient response, use a larger capacitor than the minimum 0.1 $\mu\text{F}$  capacitor between IN and GND.

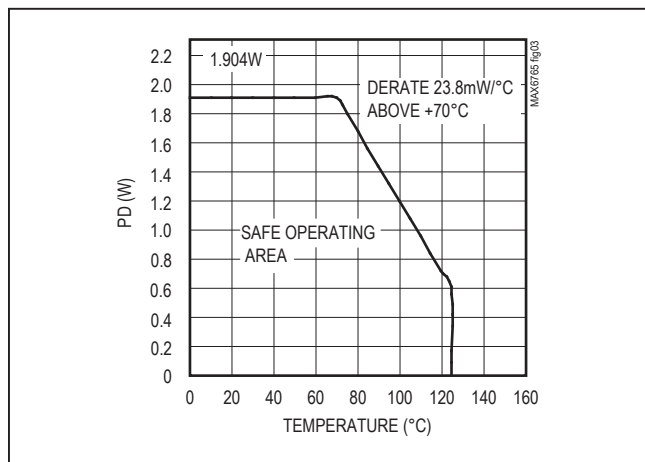

Figure 3. Maximum Power Dissipation vs. Temperature (MAX6765/MAX6766)

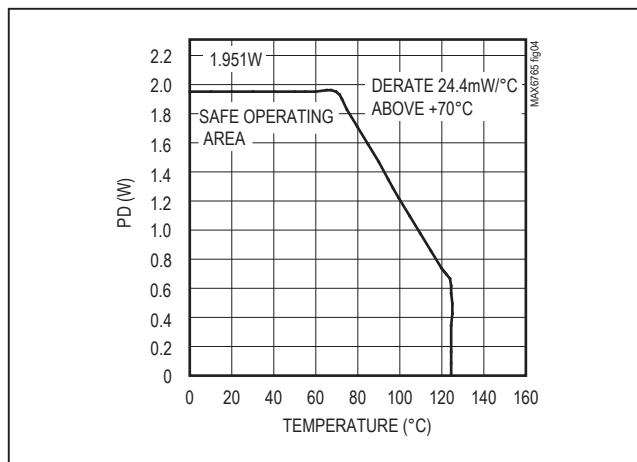

Figure 4. Maximum Power Dissipation vs. Temperature (MAX6767–MAX6774B)

**Ensuring a Valid  $\overline{\text{RESET}}$  Output Down to  $V_{\text{IN}} = 0\text{V}$  (MAX6766/MAX6768/MAX6770/MAX6772/MAX6774/MAX6774B)**

When  $V_{\text{IN}}$  falls below 1V,  $\overline{\text{RESET}}$  current-sinking capabilities decline drastically. High-impedance CMOS-logic inputs connected to  $\overline{\text{RESET}}$  can drift to undetermined voltages. This presents no problems in most applications, since most  $\mu\text{Ps}$  and other circuitry do not operate with supply voltages below 1V. In applications where  $\overline{\text{RESET}}$  must be valid down to 0V, adding a pull-down resistor between  $\overline{\text{RESET}}$  and ground sinks any stray leakage currents, holding  $\overline{\text{RESET}}$  low (Figure 5). The value of the pull-down resistor is not critical; 100k $\Omega$  is large enough not to load  $\overline{\text{RESET}}$  and small enough to pull  $\overline{\text{RESET}}$  to ground. Open-drain  $\overline{\text{RESET}}$  versions are not recommended for applications requiring valid logic for  $V_{\text{IN}}$  down to 0V.

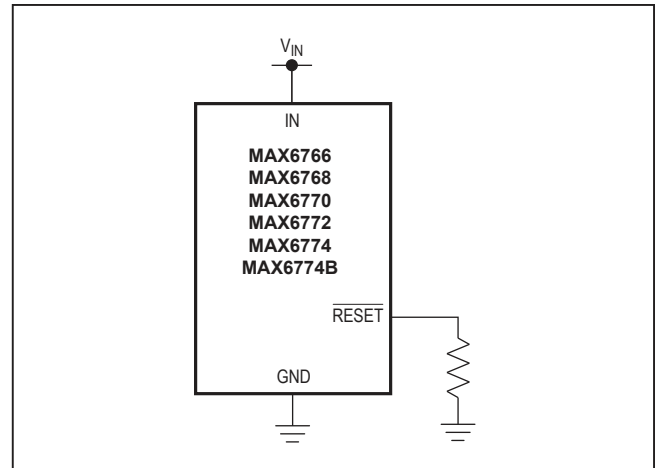

Figure 5. Ensuring  $\overline{\text{RESET}}$  Valid to  $V_{\text{IN}} = 0\text{V}$

**Table 4. Standard Version Part Numbers**

PART	OUTPUT VOLTAGE (V)	$\overline{\text{RESET}}$ TIMEOUT PERIOD (ms)	RESET THRESHOLD (V)	RESETIN THRESHOLD (V)	TOP MARK
MAX6765TTLD2+T	5	12.5	4.625	—	+AQB
MAX6765TTLD2/V+T	5	12.5	4.625	—	+AVC
MAX6765TTSD2+T	3.3	12.5	2.888	—	+AQL
MAX6765TTSD2/V+T	3.3	12.5	2.888	—	+AUQ
MAX6766TTLD2+T	5	12.5	4.625	—	+ARO
MAX6766TTSD2+T	3.3	12.5	2.888	—	+ARZ
MAX6767TALD2+T	5	12.5	4.625	—	+AVI
MAX6767TALD2/V+T	5	12.5	4.625	—	+BRK
MAX6767TASD2+T	3.3	12.5	2.888	—	+AVS
MAX6768TALD2+T	5	12.5	4.625	—	+AVZ
MAX6768TASD2+T	3.3	12.5	2.888	—	+AXE
MAX6769TALD2+T	5	12.5	—	1.147	+AYH
MAX6769TASD2+T	3.3	12.5	—	1.085	+AYQ
MAX6769TALD2/V+T	5	12.5	—	1.147	+BQF
MAX6770TALD2+T	5	12.5	—	1.147	+AZS
MAX6770TASD2+T	3.3	12.5	—	1.085	+BAC
MAX6771TALD2+T	5	12.5	4.625	—	+BEG
MAX6771TASD2+T	3.3	12.5	2.888	—	+BEQ
MAX6772TALD2+T	5	12.5	4.625	—	+APY
MAX6772TASD2+T	3.3	12.5	2.888	—	+BGC
MAX6773TALD2+T	5	12.5	4.625	—	+BBG
MAX6773TASD2+T	3.3	12.5	2.888	—	+AQE
MAX6773BTALD2+T	5	12.5	4.625	—	+BHK
MAX6773BTASD2+T	3.3	12.5	2.888	—	+BHU
MAX6773BTASD2/V+T	3.3	12.5	2.888	—	+BNN
MAX6774TALD2+T	5	12.5	4.625	—	+BCS
MAX6774TASD2+T	3.3	12.5	2.888	—	+BDC
MAX6774BTALD2+T	5	12.5	4.625	—	+BIY
MAX6774BTASD2+T	3.3	12.5	2.888	—	+BJI

Selector Guide

PART	RESET OUTPUT	TYPICAL WATCHDOG TIMEOUT	OUTPUT VOLTAGE	RESETIN THRESHOLD	ENABLE INPUTS	HOLD INPUT
MAX6765	Open drain	—	Fixed	—	Single	—
MAX6766	Push-pull	—	Fixed	—	Single	—
MAX6767	Open drain	—	Fixed/Adj	—	Single	√
MAX6768	Push-pull	—	Fixed/Adj	—	Single	√
MAX6769	Open drain	—	Fixed/Adj	√	Single	—
MAX6770	Push-pull	—	Fixed/Adj	√	Single	—
MAX6771	Open drain	—	Fixed/Adj	—	Dual	—
MAX6772	Push-pull	—	Fixed/Adj	—	Dual	—
MAX6773	Open drain	1.6s	Fixed/Adj	—	Single	—
MAX6773B	Open drain	50ms	Fixed/Adj	—	Single	—
MAX6774	Push-pull	1.6s	Fixed/Adj	—	Single	—
MAX6774B	Push-pull	50ms	Fixed/Adj	—	Single	—

Typical Application Circuit

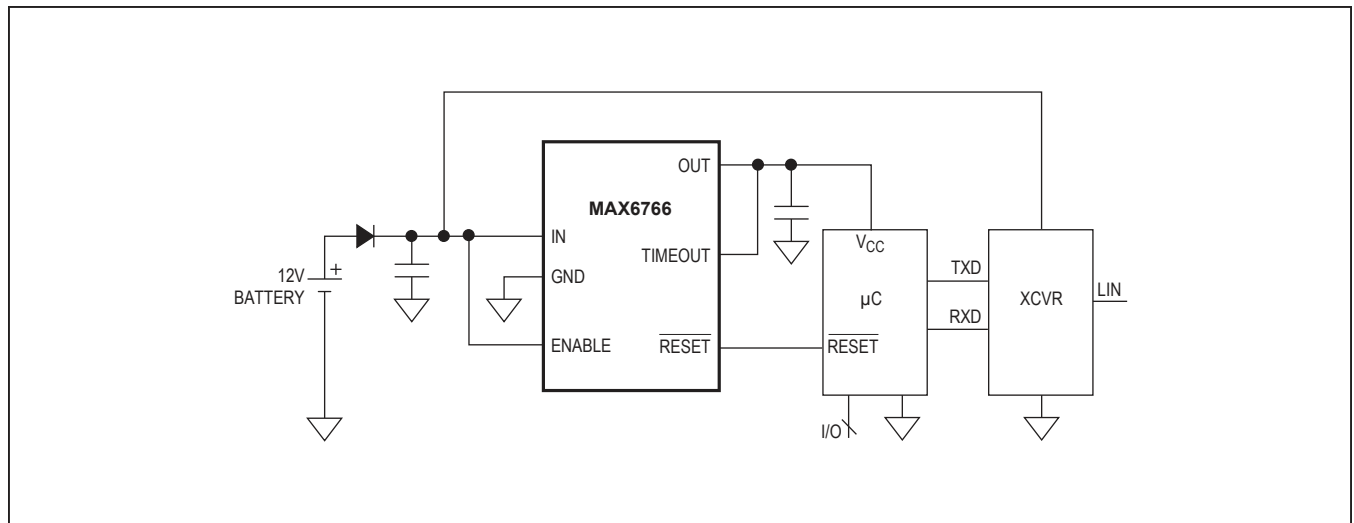

Pin Configurations (continued)

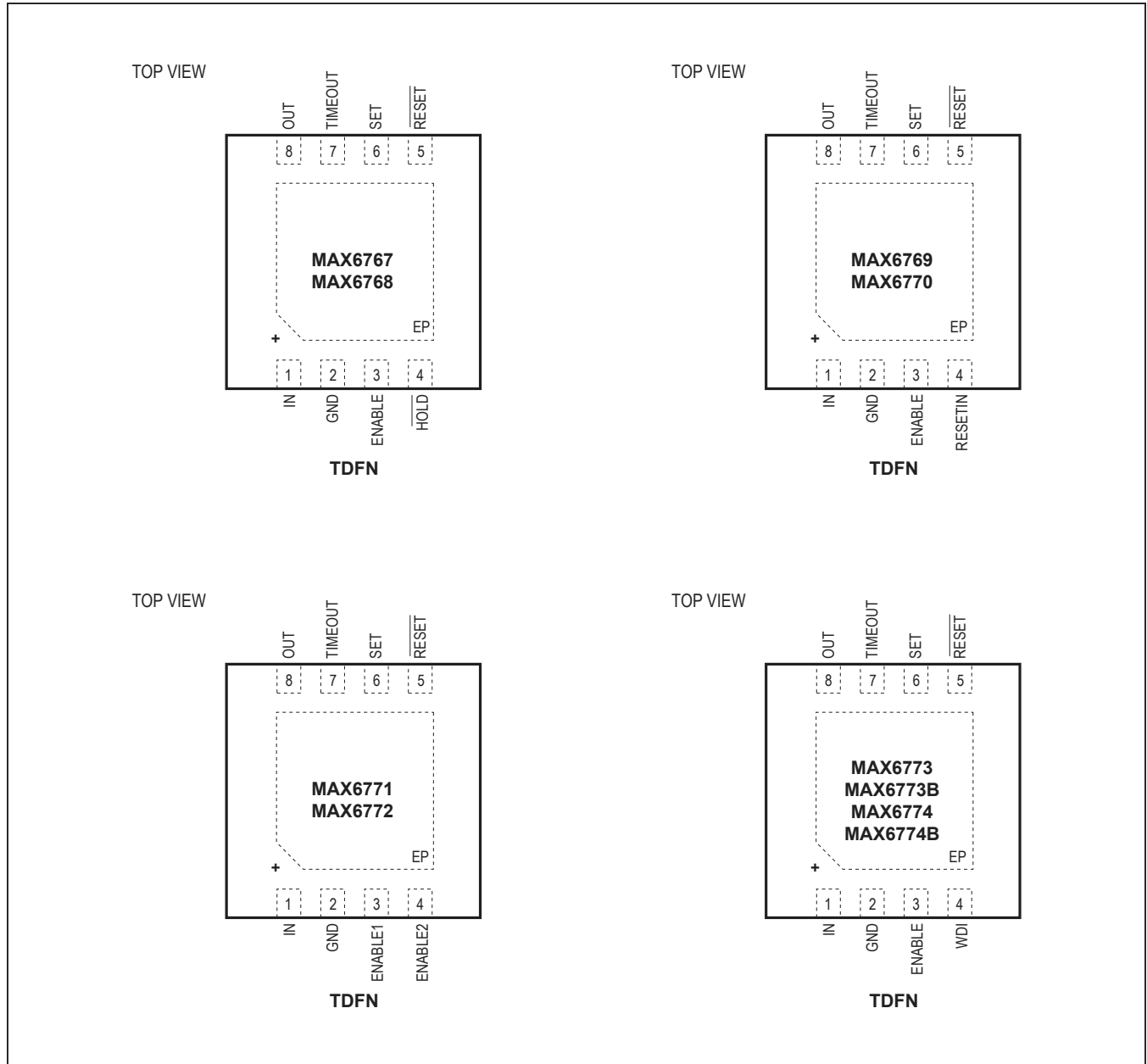

## Ordering Information (continued)

PART	TEMP RANGE	PIN-PACKAGE
MAX6766TT_D_+	-40°C to +125°C	8 TDFN-EP*
MAX6767TA_D_/V+	-40°C to +125°C	8 TDFN-EP*
MAX6768TA_D_+	-40°C to +125°C	8 TDFN-EP*
MAX6769TA_D_+	-40°C to +125°C	8 TDFN-EP*
MAX6769TA_D_/V+	-40°C to +125°C	8 TDFN-EP*
MAX6770TA_D_+	-40°C to +125°C	8 TDFN-EP*
MAX6771TA_D_+	-40°C to +125°C	8 TDFN-EP*
MAX6772TA_D_+	-40°C to +125°C	8 TDFN-EP*
MAX6773TA_D_/V+	-40°C to +125°C	8 TDFN-EP*
MAX6773BTA_D_/V+	-40°C to +125°C	8 TDFN-EP*
MAX6774TA_D_+	-40°C to +125°C	8 TDFN-EP*
MAX6774BTA_D_+	-40°C to +125°C	8 TDFN-EP*

The first “\_” is a placeholder for the voltage output and reset threshold. The 2nd “\_” designates the fixed reset-timeout option. See Tables 1 and 2 for details. For example, the MAX6765TTL4 has a 5V output, a reset threshold of 4.65V, and a 200ms typical reset timeout.

+Denotes a lead(Pb)-free/RoHS-compliant package.

/V denotes an automotive qualified part.

\*EP = Exposed pad.

For tape-and-reel orders add a “T” after the “+” symbol to complete the part number. Tape-and-reel orders are available in 2.5k increments. Nonstandard versions require a 10k minimum order quantity.

## Chip Information

PROCESS: BiCMOS

## Revision History

REVISION NUMBER	REVISION DATE	DESCRIPTION	PAGES CHANGED
0	10/06	Initial release	—
1	1/07	Introduced MAX6765 and MAX6766	1, 21, 23
2	7/07	Added the MAX6773B and MAX6774D to data sheet. Updated <i>Features</i> , <i>General Description</i> , <i>Ordering Information</i> , <i>Functional Diagrams</i> , <i>Table 4</i> , <i>Selector Guide</i> , <i>Watchdog Timer</i> section, and <i>Pin Configurations</i> .	1, 4, 8, 9, 14, 16, 18–23
3	9/07	Revised <i>Typical Operating Characteristics</i>	7
4	6/10	Added <i>V</i> to the MAX6765TT_D_+	1
5	10/11	Added <i>V</i> to the MAX6773TA_D_+; added Timeout ramp threshold to <i>Electrical Characteristics</i> table. Changed $t_{RP}$ formula in <i>Selecting Timeout Capacitor</i> section.	4, 17, 21
6	3/12	Added <i>V</i> to the MAX6769TA_D_+ <i>V</i>	21
7	10/12	Added <i>V</i> to the MAX6767TA_D_+ <i>V</i>	21
8	4/13	Updated Tables 2 and 4	15, 18
9	8/17	Added AEC-Q100 to <i>Features</i> section and updated Table 4	1, 18
10	11/18	Updated <i>Package Information</i> section	2, 22

For pricing, delivery, and ordering information, please visit Maxim Integrated's online storefront at <https://www.maximintegrated.com/en/storefront/storefront.html>.

Maxim Integrated cannot assume responsibility for use of any circuitry other than circuitry entirely embodied in a Maxim Integrated product. No circuit patent licenses are implied. Maxim Integrated reserves the right to change the circuitry and specifications without notice at any time. The parametric values (min and max limits) shown in the *Electrical Characteristics* table are guaranteed. Other parametric values quoted in this data sheet are provided for guidance.