

PI6C49CB04CJ

Industrial Grade low skew, 1-to-4 LVCMOS/LVTTL Fanout Buffer

Features

- Low Skew Outputs
- Low Power CMOS Technology
- Operating Voltages of 1.5V to 3.3V
- Output Enable pin Tri-States Outputs
- 3.6V Tolerant Input Clock
- Maximum Output Frequency: 160MHz
- Totally Lead-Free & Fully RoHS Compliant (Notes 1 & 2)
- Halogen and Antimony Free. "Green" Device (Note 3)
- For automotive applications requiring specific change control (i.e. parts qualified to AEC-Q100/101/200, PPAP capable, and manufactured in IATF 16949 certified facilities), please [contact us](mailto:contact@diodes.com) or your local Diodes representative.
<https://www.diodes.com/quality/product-definitions/>
- Packaging (Pb-free & Green): 8-pin, SOIC (W)
 - Small 8-pin SOIC(W) package saves board space

Description

The PI6C49CB04CJ is an industrial grade low-skew, 1-to-4 fanout buffer. Guaranteed output and part-to-part skew characteristics make the PI6C49CB04CJ ideal for clock distribution applications that demand well-defined performance and repeatability.

Block Diagram

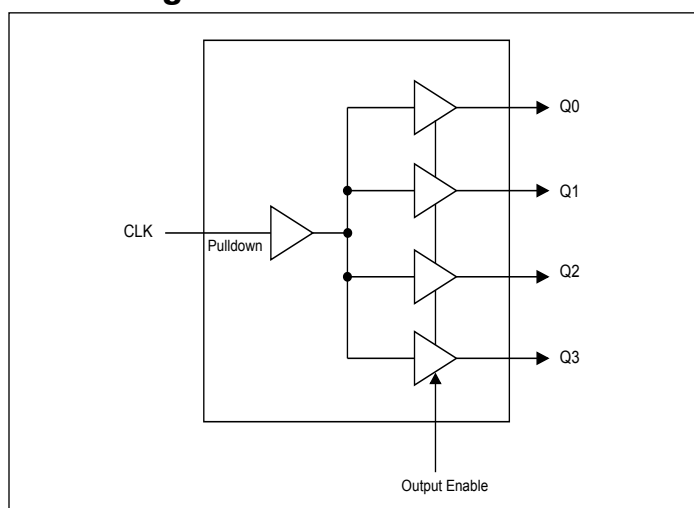

Notes:

1. No purposely added lead. Fully EU Directive 2002/95/EC (RoHS), 2011/65/EU (RoHS 2) & 2015/863/EU (RoHS 3) compliant.
2. See <https://www.diodes.com/quality/lead-free/> for more information about Diodes Incorporated's definitions of Halogen- and Antimony-free, "Green" and Lead-free.
3. Halogen- and Antimony-free "Green" products are defined as those which contain <900ppm bromine, <900ppm chlorine (<1500ppm total Br + Cl) and <1000ppm antimony compounds.

Pin Configuration

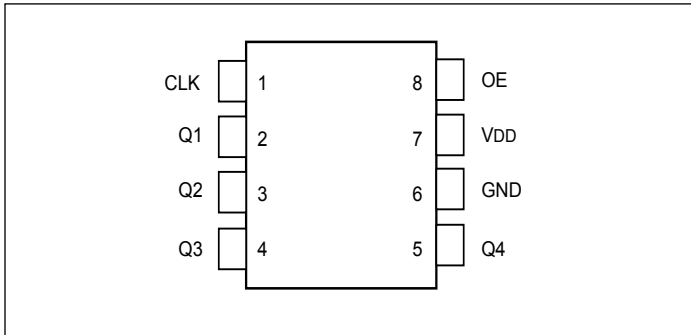

Pin Descriptions

Pin#	Pin Name	Pin Type	Pin Description
1	CLK	Input	Clock Input. 3.3 V tolerant input. Internal 51k Ω pulldown resistor.
2	Q1	Output	Clock Output 1
3	Q2	Output	Clock Output 2
4	Q3	Output	Clock Output 3
5	Q4	Output	Clock Output 4
6	GND	Power	Connect to ground
7	VDD	Power	Connect to 1.5V, 1.8V, 2.5V, or 3.3V
8	OE	Input	Output Enable. Tri-states outputs when low. Internal 125K Ω pullup resistor. Default on.

External Components

A minimum number of external components are required for proper operation. A decoupling capacitor of 0.01 μ F should be connected between VDD on pin 7 and GND on pin 6, as close to the device as possible. A 33 Ω series terminating resistor may be used on each clock output if the trace is longer than 1 inch.

Maximum Ratings

Supply Voltage, VDD	4.6V
Output Enable and All Outputs	-0.5V to VDD+0.5V
CLK	-0.5V to 3.6V (VDD > 0V)
Storage Temperature	-65°C to +150°C
ESD Protection (HBM)	2000V
Junction Temperature	125°C max

Note:

Stresses above the ratings listed below can cause permanent damage to the PI6C49X0204CQ. Functional operation of the device at these or any other conditions above those indicated in the operational sections of the specifications is not implied.

Exposure to absolute maximum rating conditions for extended periods can affect product reliability. Electrical parameters are guaranteed only over the recommended operating temperature range.

Recommended Operation Conditions

Parameter	Min.	Typ.	Max.	Units
Ambient Operating Temperature	-40	—	+105	°C
Power Supply Voltage (Measured in Respect to GND)	+1.425	—	+3.6	V

DC Electrical Characteristics

VDD=1.5 V ±5%, Ambient temperature -40°C to +105°C, unless stated otherwise

Symbol	Parameter	Conditions	Min.	Typ.	Max.	Units
VDD	Operating Voltage	—	1.425	1.5	1.575	V
V _{IH}	Input High Voltage	CLK ⁽¹⁾	0.9	—	3.6	V
V _{IL}	Input Low Voltage	CLK ⁽¹⁾	—	—	0.575	V
I _{IH}	Input High Current	CLK ⁽¹⁾	—	—	40	μA
I _{IL}	Input Low Current	CLK ⁽¹⁾	—	—	1	μA
I _{IH}	Input High Current	OE ⁽¹⁾	—	—	1	μA
I _{IL}	Input Low Current	OE ⁽¹⁾	—	—	40	μA
V _{OH}	Output High Voltage	I _{OH} = -6mA	0.95	—	—	V
V _{OL}	Output Low Voltage	I _{OL} = 6mA	—	—	0.45	V
IDD	Operating Supply Current	5pF, 160MHz	—	15	21	mA
		5pF, 100MHz	—	13	17	mA
		5pF, 50MHz	—	7	9	mA
		5pF, 25MHz	—	4	5.5	mA
Z _O	Nominal Output Impedance	—	—	20	—	Ω
C _{IN}	Input Capacitance	CLK, OE pin	—	5	—	pF
I _{OS}	Short-Circuit Current	—	—	±12	—	mA

Notes: 1. Nominal switching threshold is VDD/2.

VDD=1.8 V ±5%, Ambient temperature -40°C to +105°C, unless stated otherwise

Symbol	Parameter	Conditions	Min.	Typ.	Max.	Units
VDD	Operating Voltage	—	1.7	1.8	1.89	V
V _{IH}	Input High Voltage	CLK ⁽¹⁾	1.1	—	3.6	V
V _{IL}	Input Low Voltage	CLK ⁽¹⁾	—	—	0.6	V
I _{IH}	Input High Current	CLK ⁽¹⁾	—	—	50	μA
I _{IL}	Input Low Current	CLK ⁽¹⁾	—	—	1	μA
I _{IH}	Input High Current	OE ⁽¹⁾	—	—	1	μA
I _{IL}	Input Low Current	OE ⁽¹⁾	—	—	50	μA
V _{OH}	Output High Voltage	I _{OH} = -8mA	1.4	—	—	V
V _{OL}	Output Low Voltage	I _{OL} = 8mA	—	—	0.4	V
IDD	Operating Supply Current	5pF, 160MHz	—	22	28	mA
		5pF, 100MHz	—	17	21	mA
		5pF, 50MHz	—	9	12	mA
		5pF, 25MHz	—	5	7	mA
Z _O	Nominal Output Impedance	—	—	20	—	Ω
C _{IN}	Input Capacitance	CLK, OE pin	—	5	—	pF
I _{OS}	Short Circuit Current	—	—	±20	—	mA

Notes: 1. Nominal switching threshold is VDD/2.

VDD=2.5 V ±5%, Ambient temperature -40°C to +105°C, unless stated otherwise

Symbol	Parameter	Conditions	Min.	Typ.	Max.	Units
VDD	Operating Voltage	—	2.375	2.5	2.625	V
V _{IH}	Input High Voltage	CLK ⁽¹⁾	1.7	—	3.6	V
V _{IL}	Input Low Voltage	CLK ⁽¹⁾	—	—	0.7	V
I _{IH}	Input High Current	CLK ⁽¹⁾	—	—	60	μA
I _{IL}	Input Low Current	CLK ⁽¹⁾	—	—	1	μA
I _{IH}	Input High Current	OE ⁽¹⁾	—	—	1	μA
I _{IL}	Input Low Current	OE ⁽¹⁾	—	—	60	μA
V _{OH}	Output High Voltage	I _{OH} = -8mA	2	—	—	V
V _{OL}	Output Low Voltage	I _{OL} = 8mA	—	—	0.4	V
IDD	Operating Supply Current	5pF, 100MHz	—	24	30	mA
		5pF, 50MHz	—	12	15	mA
		5pF, 25MHz	—	7	9	mA
Z _O	Nominal Output Impedance	—	—	20	—	Ω
C _{IN}	Input Capacitance	CLK, OE pin	—	5	—	pF
I _{OS}	Short-Circuit Current	—	—	±50	—	mA

Notes: 1. Nominal switching threshold is VDD/2.

VDD=3.3 V ±10%, Ambient temperature -40°C to +105°C, unless stated otherwise

Symbol	Parameter	Conditions	Min.	Typ.	Max.	Units
VDD	Operating Voltage	—	3.0	3.3	3.6	V
V _{IH}	Input High Voltage	CLK ⁽¹⁾	2.4	—	3.6	V
V _{IL}	Input Low Voltage	CLK ⁽¹⁾	—	—	0.7	V
I _{IH}	Input High Current	CLK ⁽¹⁾	—	—	85	μA
I _{IL}	Input Low Current	CLK ⁽¹⁾	—	—	1	μA
I _{IH}	Input High Current	OE ⁽¹⁾	—	—	1	μA
I _{IL}	Input Low Current	OE ⁽¹⁾	—	—	85	μA
V _{OH}	Output High Voltage	I _{OH} = -8mA	2.8	—	—	V
V _{OL}	Output Low Voltage	I _{OL} = 8mA	—	—	0.2	V
IDD	Operating Supply Current	5pF, 100MHz	—	32	38	mA
		5pF, 50MHz	—	16	19	mA
		5pF, 25MHz	—	10	12	mA
Z _O	Nominal Output Impedance	—	—	20	—	Ω
C _{IN}	Input Capacitance	CLK, OE pin	—	5	—	pF
I _{OS}	Short-Circuit Current	—	—	±50	—	mA

Notes: 1. Nominal switching threshold is VDD/2.

AC Electrical Characteristics

VDD=1.5 V ±5%, Ambient temperature -40°C to +105°C, unless stated otherwise

Symbol	Parameter	Conditions	Min.	Typ.	Max.	Units
F _{OUT}	Output Frequency	—	0	—	160	MHz
t _{OR}	Output Rise Time	20% to 80%	—	1.0	1.5	ns
t _{OF}	Output Fall Time	20% to 80%	—	1.0	1.5	ns
T _{PD}	Propagation Delay ⁽¹⁾	—	2	3	5	ns
T _{SK}	Output-to-Output Skew ⁽²⁾	Rising edges at VDD/2	—	0	±250	ps

VDD=1.8 V ±5%, Ambient temperature -40°C to +105°C, unless stated otherwise

Symbol	Parameter	Conditions	Min.	Typ.	Max.	Units
F _{OUT}	Output Frequency	—	0	—	160	MHz
t _{OR}	Output Rise Time	20% to 80%	—	1.0	1.5	ns
t _{OF}	Output Fall Time	20% to 80%	—	1.0	1.5	ns
T _{PD}	Propagation Delay ⁽¹⁾	—	1.3	2	4	ns
T _{SK}	Output-to-Output Skew ⁽²⁾	Rising edges at VDD/2	—	0	±250	ps
J _{ADD}	Additive Jitter	@ 156.25MHz, 12k to 20MHz	—	0.1	—	ps

PI6C49CB04CJ

VDD=2.5 V ±5%, Ambient temperature -40 to +105°C, unless stated otherwise

Symbol	Parameter	Conditions	Min.	Typ.	Max.	Units
F _{OUT}	Output Frequency	—	0	—	160	MHz
t _{OR}	Output Rise Time	20% TO 80%	—	1.0	1.5	ns
t _{OF}	Output Fall Time	20% TO 80%	—	1.0	1.5	ns
T _{PD}	Propagation Delay ⁽¹⁾	—	0.8	1.5	3	ns
T _{SK}	Output-to-Output Skew ⁽²⁾	Rising edges at VDD/2	—	0	±250	ps
J _{ADD}	Additive Jitter	@ 156.25MHz, 12k to 20MHz	—	0.05	—	ps

VDD=3.3 V ±10%, Ambient temperature -40°C to +105°C, unless stated otherwise

Symbol	Parameter	Conditions	Min.	Typ.	Max.	Units
F _{OUT}	Output Frequency	—	0	—	100	MHz
t _{OR}	Output Rise Time	20% TO 80%	—	1.0	1.5	ns
t _{OF}	Output Fall Time	20% TO 80%	—	1.0	1.5	ns
T _{PD}	Propagation Delay ⁽¹⁾	—	0.8	1.0	2.5	ns
T _{SK}	Output-to-Output Skew ⁽²⁾	Rising edges at VDD/2	—	0	±250	ps
J _{ADD}	Additive Jitter	@ 156.25MHz, 12k to 20MHz	—	0.05	—	ps

Notes:

1. With rail-to-rail input clock.
2. Between any two outputs with equal loading.

Phase Noise Plot

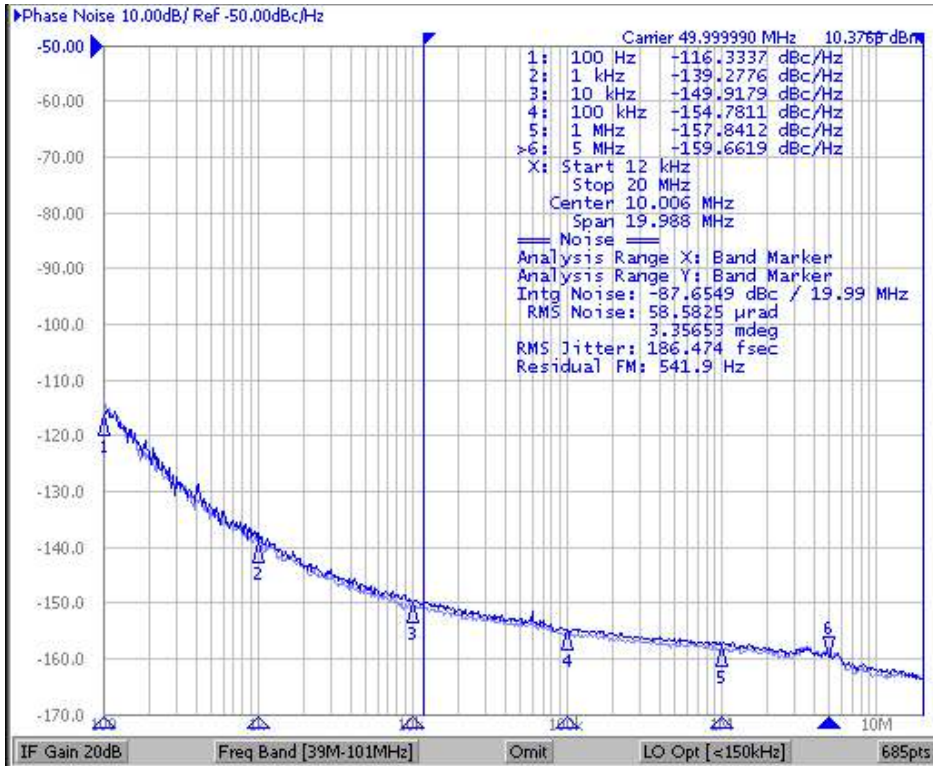

Thermal Characteristics

Symbol	Parameter	Conditions	Min.	Typ.	Max.	Units
θJA	Thermal Resistance Junction to Ambient	Still air	—	157	—	°C/W
θJC	Thermal Resistance Junction to Case	—	—	42	—	°C/W

Application Information

Suggest for Unused Inputs and Outputs

LVC MOS Input Control Pins

It is suggested to add pullup = 4.7k and pulldown = 1k for LVC MOS pins even though they have internal pullup/pulldown but with much higher value ($\geq 50k$) for higher design reliability.

Outputs

All unused outputs are suggested to be left open and not connected to any trace. This can lower the IC power consumption.

Power Decoupling & Routing

VDD Pin Decoupling

Each VDD pin must have a 0.1 μ F decoupling capacitor. For better decoupling, 1 μ F can be used. Placing the decoupling capacitor on the component side improves decoupling filter results, as shown below.

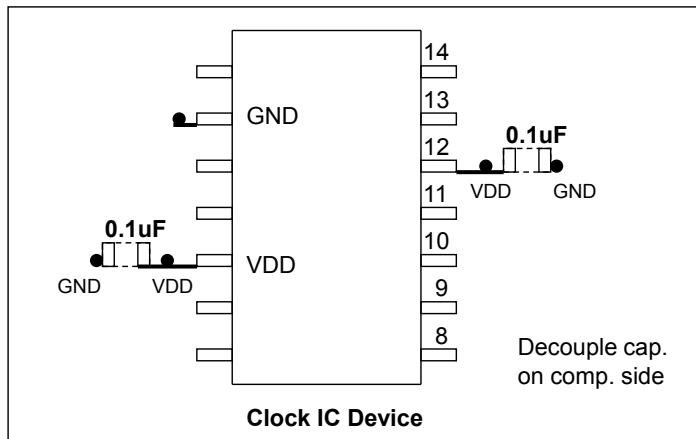

Placement of Decoupling Capacitors

CMOS Clock Trace Routing

Ensure there is a sufficient keep-out area to the adjacent trace ($> 20\text{mil.}$). In an example using a 125MHz XO driving a buffer IC, it is better to route the clock trace on the component side with a 33 Ω termination resistor.

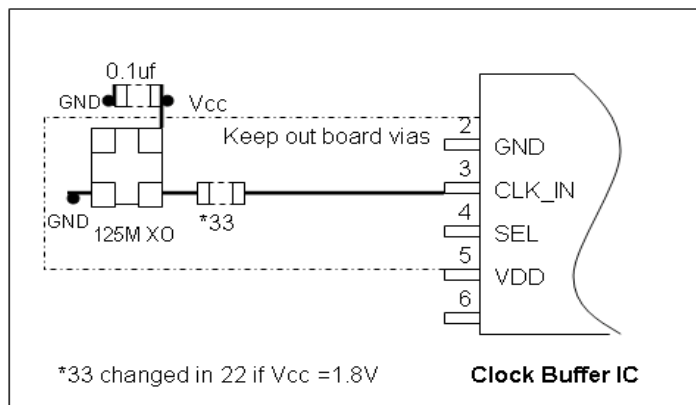

CMOS Output Termination

Popular CMOS Output Termination

The most popular CMOS termination is a serial resistor close to the output pin ($\leq 200\text{mil}$). It is simple and balances the drive strength. The resistor's value can be fine tuned for best performance during board bring-up based on VDDO voltage used.

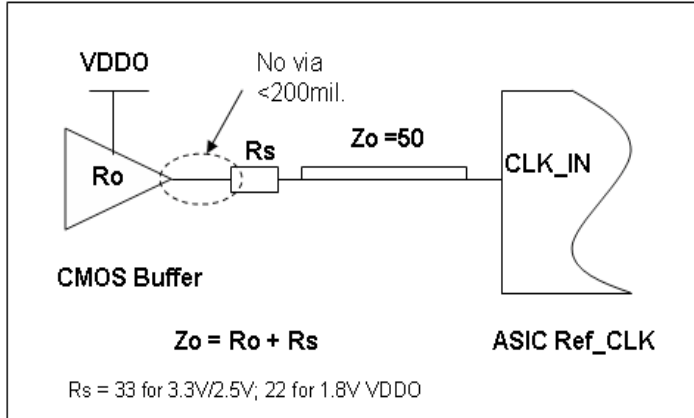

Combining Serial and Parallel Termination

Designers can also use a parallel termination for CMOS outputs. For example, a 50Ω pulldown resistor can be used at the Rx side to reduce signal reflection, but it reduces the signals V_{swing} in half. This pulldown can be combined with a serial resistor to form a smaller clock voltage difference. The following diagram shows how to transition a 2.5V clock into 1.8V clock.

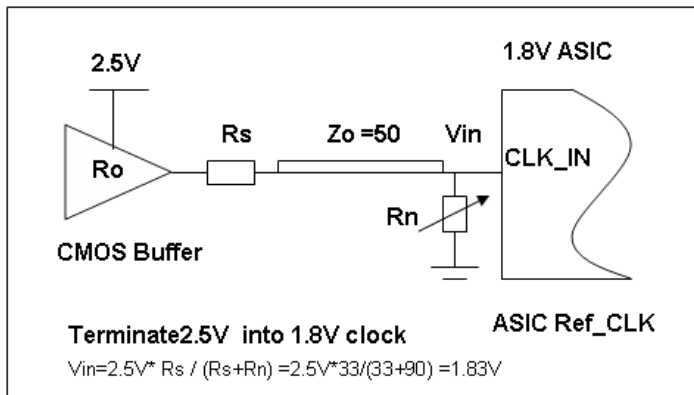

$R_s = 33\Omega$ with $R_n = 100\Omega$, to transition 3.3V CMOS to 2.5V

$R_s = 43\Omega$ with $R_n = 70\Omega$ to transition 3.3V CMOS to 1.8V

Clock Jitter Definitions

Total jitter= RJ + DJ

Random Jitter (RJ) is unpredictable and unbounded timing noise that can fit in a Gaussian math distribution in RMS. RJ test values are directly related to how long or how many test samples are available. Deterministic jitter (DJ) is timing jitter that is predictable and periodic in fixed interference frequency. Total jitter (TJ) is the combination of random jitter and deterministic jitter, where factors are based on total test sample count. JEDEC std. specifies digital clock TJ in 10k random samples.

Phase Jitter

Phase noise is short-term random noise attached on the clock carrier and it is a function of the clock offset from the carrier, for example dBc/Hz @ 10kHz, which is phase noise power in 1-Hz normalized bandwidth vs. the carrier power @ 10kHz offset. Integration of phase noise in plot over a given frequency band yields RMS phase jitter, for example, to specify phase jitter $\leq 1\text{ps}$ at 12k to 20MHz offset band as SONET standard specification.

Device Thermal Calculation

The JEDEC thermal model in a 4-layer PCB is shown below.

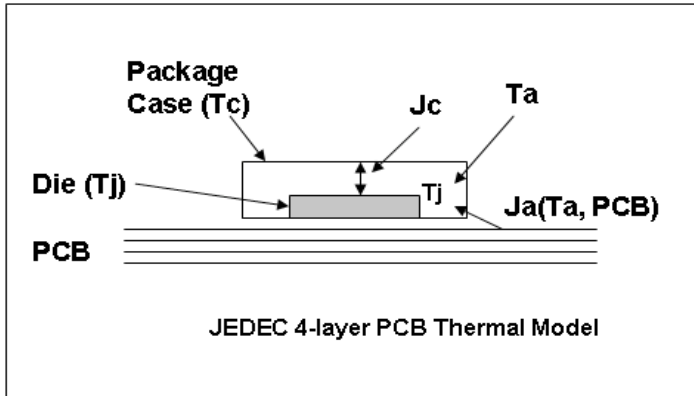

JEDEC IC Thermal Model

Important factors to influence device operating temperature are:

- 1) The power dissipation from the chip (P_{chip}) is found after subtracting power dissipation from external loads. Generally it can be the no-load device I_{dd} .
- 2) Package type and PCB stack-up structure, for example, 1oz 4-layer board. PCB have more layers and are thicker, which improves heat dissipation.
- 3) Chassis air flow and cooling mechanism. More air flow M/s and adding heat sink on device can reduce device final die junction temperature T_j .

The individual device thermal calculation formula:

$$T_j = T_a + P_{chip} \times J_a$$

$$T_c = T_j - P_{chip} \times J_c$$

J_a ___ Package thermal resistance from die to the ambient air in C/W unit. This data is provided in JEDEC model simulation. An air flow of $1m/s$ will reduce J_a (still air) by 20% ~ 30%.

J_c ___ Package thermal resistance from die to the package case in C/W unit.

T_j ___ Die junction temperature in C (industry limit $< 125C$ max).

T_a ___ Ambient air temperature in C .

T_c ___ Package case temperature in C .

P_{chip} ___ IC actually consumes power through I_{ee}/GND current.

Part Marking

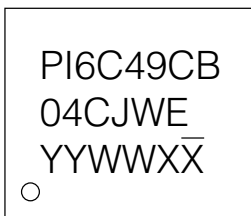

YY: Year

WW: Workweek

1st X: Assembly Code

2nd X: Fab Code

PI6C49CB04CJ

Packaging Mechanical: 8-SOIC (W)

SYMBOLS	MIN.	NOM.	MAX.
A	—	—	1.75
A1	0.10	—	0.25
A2	1.25	—	—
b	0.31	—	0.51
c	0.10	—	0.25
D	4.80	4.90	5.00
E	5.80	6.00	6.20
E1	3.80	3.90	4.00
e	1.27 BSC		
L	0.40	—	1.27
h	0.25	—	0.50
θ°	0	—	8

Recommended Land Pattern

NOTE :
 1. ALL DIMENSIONS ARE IN mm. ANGLES IN DEGREES
 2. DIMENSIONS EXCLUDE BURRS, MOLD FLASH OR PROTRUSIONS
 3. REFER JEDEC MS-012
 4. RECOMMENDED LAND PATTERN IS FOR REFERENCE ONLY.

20-1273

DIODES INCORPORATED	PERICOM ENABLING SERIAL CONNECTIVITY	DATE: 06/02/20
DESCRIPTION: 8-Pin, 150mil-Wide, SOIC		
PACKAGE CODE: W (W8)		
DOCUMENT CONTROL #: PD-1001	REVISION: H	

For latest package information:

See <http://www.diodes.com/design/support/packaging/pericom-packaging/packaging-mechanicals-and-thermal-characteristics/>.

Ordering Information

Ordering Code	Package Code	Package Description
PI6C49CB04CJWEX	W	8-pin, 150mil-Wide (SOIC)

Notes:

1. No purposely added lead. Fully EU Directive 2002/95/EC (RoHS), 2011/65/EU (RoHS 2) & 2015/863/EU (RoHS 3) compliant.
2. See <https://www.diodes.com/quality/lead-free/> for more information about Diodes Incorporated's definitions of Halogen- and Antimony-free, "Green" and Lead-free.
3. Halogen- and Antimony-free "Green" products are defined as those which contain <900ppm bromine, <900ppm chlorine (<1500ppm total Br + Cl) and <1000ppm antimony compounds.
4. J = Industrial Grade
5. E = Pb-free and Green
6. X suffix = Tape/Reel

IMPORTANT NOTICE

1. DIODES INCORPORATED AND ITS SUBSIDIARIES (“DIODES”) MAKE NO WARRANTY OF ANY KIND, EXPRESS OR IMPLIED, WITH REGARDS TO ANY INFORMATION CONTAINED IN THIS DOCUMENT, INCLUDING, BUT NOT LIMITED TO, THE IMPLIED WARRANTIES OF MERCHANTABILITY, FITNESS FOR A PARTICULAR PURPOSE OR NON-INFRINGEMENT OF THIRD PARTY INTELLECTUAL PROPERTY RIGHTS (AND THEIR EQUIVALENTS UNDER THE LAWS OF ANY JURISDICTION).

2. The Information contained herein is for informational purpose only and is provided only to illustrate the operation of Diodes products described herein and application examples. Diodes does not assume any liability arising out of the application or use of this document or any product described herein. This document is intended for skilled and technically trained engineering customers and users who design with Diodes products. Diodes products may be used to facilitate safety-related applications; however, in all instances customers and users are responsible for (a) selecting the appropriate Diodes products for their applications, (b) evaluating the suitability of the Diodes products for their intended applications, (c) ensuring their applications, which incorporate Diodes products, comply the applicable legal and regulatory requirements as well as safety and functional-safety related standards, and (d) ensuring they design with appropriate safeguards (including testing, validation, quality control techniques, redundancy, malfunction prevention, and appropriate treatment for aging degradation) to minimize the risks associated with their applications.

3. Diodes assumes no liability for any application-related information, support, assistance or feedback that may be provided by Diodes from time to time. Any customer or user of this document or products described herein will assume all risks and liabilities associated with such use, and will hold Diodes and all companies whose products are represented herein or on Diodes’ websites, harmless against all damages and liabilities.

4. Products described herein may be covered by one or more United States, international or foreign patents and pending patent applications. Product names and markings noted herein may also be covered by one or more United States, international or foreign trademarks and trademark applications. Diodes does not convey any license under any of its intellectual property rights or the rights of any third parties (including third parties whose products and services may be described in this document or on Diodes’ website) under this document.

5. Diodes products are provided subject to Diodes’ Standard Terms and Conditions of Sale (<https://www.diodes.com/about/company/terms-and-conditions/terms-and-conditions-of-sales/>) or other applicable terms. This document does not alter or expand the applicable warranties provided by Diodes. Diodes does not warrant or accept any liability whatsoever in respect of any products purchased through unauthorized sales channel.

6. Diodes products and technology may not be used for or incorporated into any products or systems whose manufacture, use or sale is prohibited under any applicable laws and regulations. Should customers or users use Diodes products in contravention of any applicable laws or regulations, or for any unintended or unauthorized application, customers and users will (a) be solely responsible for any damages, losses or penalties arising in connection therewith or as a result thereof, and (b) indemnify and hold Diodes and its representatives and agents harmless against any and all claims, damages, expenses, and attorney fees arising out of, directly or indirectly, any claim relating to any noncompliance with the applicable laws and regulations, as well as any unintended or unauthorized application.

7. While efforts have been made to ensure the information contained in this document is accurate, complete and current, it may contain technical inaccuracies, omissions and typographical errors. Diodes does not warrant that information contained in this document is error-free and Diodes is under no obligation to update or otherwise correct this information. Notwithstanding the foregoing, Diodes reserves the right to make modifications, enhancements, improvements, corrections or other changes without further notice to this document and any product described herein. This document is written in English but may be translated into multiple languages for reference. Only the English version of this document is the final and determinative format released by Diodes.

8. Any unauthorized copying, modification, distribution, transmission, display or other use of this document (or any portion hereof) is prohibited. Diodes assumes no responsibility for any losses incurred by the customers or users or any third parties arising from any such unauthorized use.

Copyright © 2021 Diodes Incorporated

www.diodes.com