

LOC	DIST	REVISIONS					
		P.	LTN	DESCRIPTION	DATE	DWN	APVD
CM	00	D2		REVISED PER ECO-17-011927	22AUG2017	RS	KR

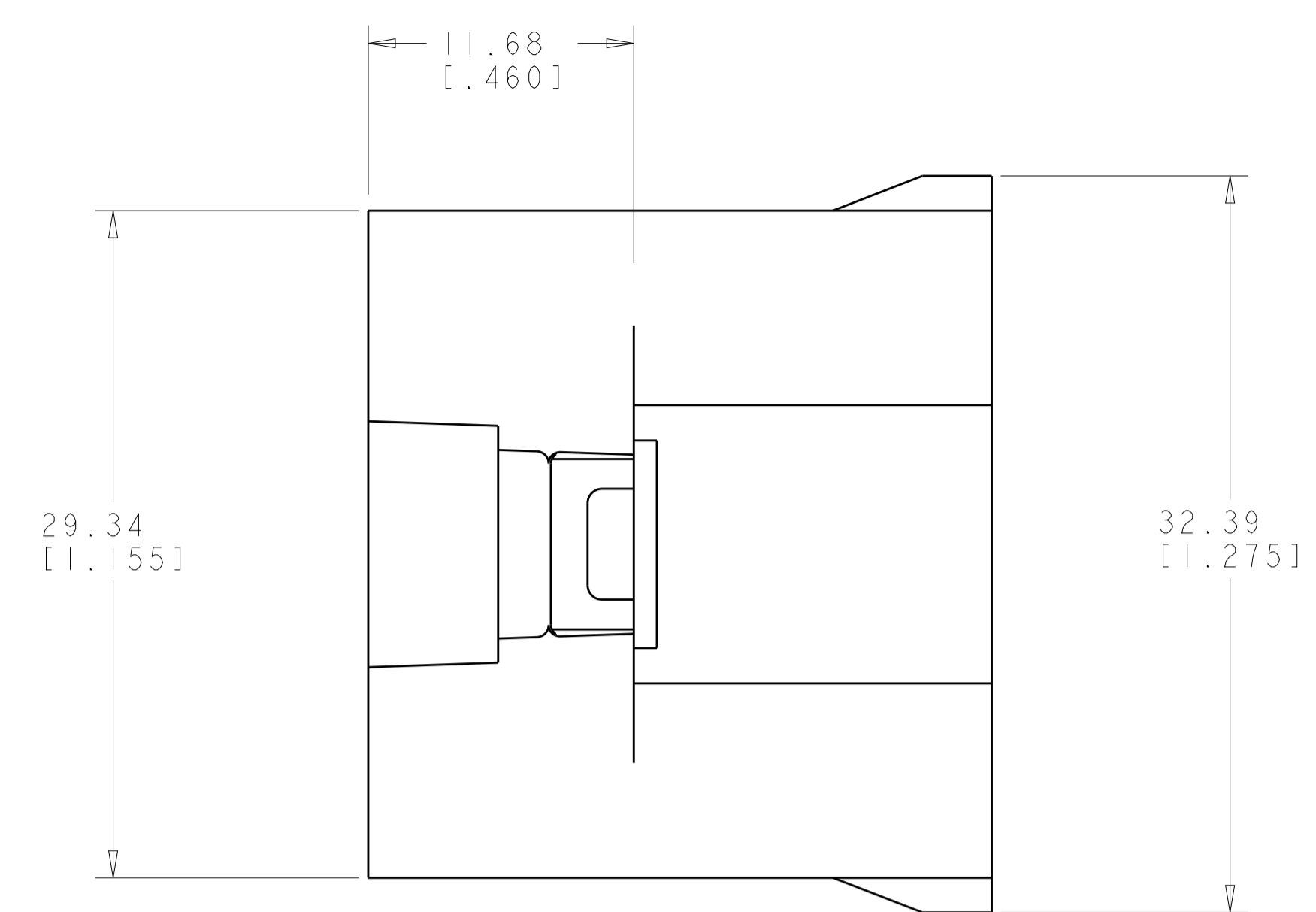

- THE DIMENSIONS OF THIS CONNECTOR ARE CONTROLLED BY THE MATING PART 770855. BOTH CONNECTOR'S DIMENSIONING ARE BASED ON A FAN MOTOR MANUFACTURED BY G.E. MOTORS. NO DIMENSIONAL CHANGES ON EITHER PART MAY OCCUR WITHOUT CONSULTING G.E. MOTORS.
- TRADEMARK LOCATION (AMP OR TYCO).
- MANUFACTURING LOCATION ID (OPTIONAL).
- DIMENSIONS SHOWN REPRESENT PRODUCT IN DRY, AS MOLDED CONDITION ADDITIONAL 2% GROWTH DUE TO SUBSEQUENT MOISTURE ABSORPTION MAY OCCUR AND SHOULD BE ACCOUNTED FOR.

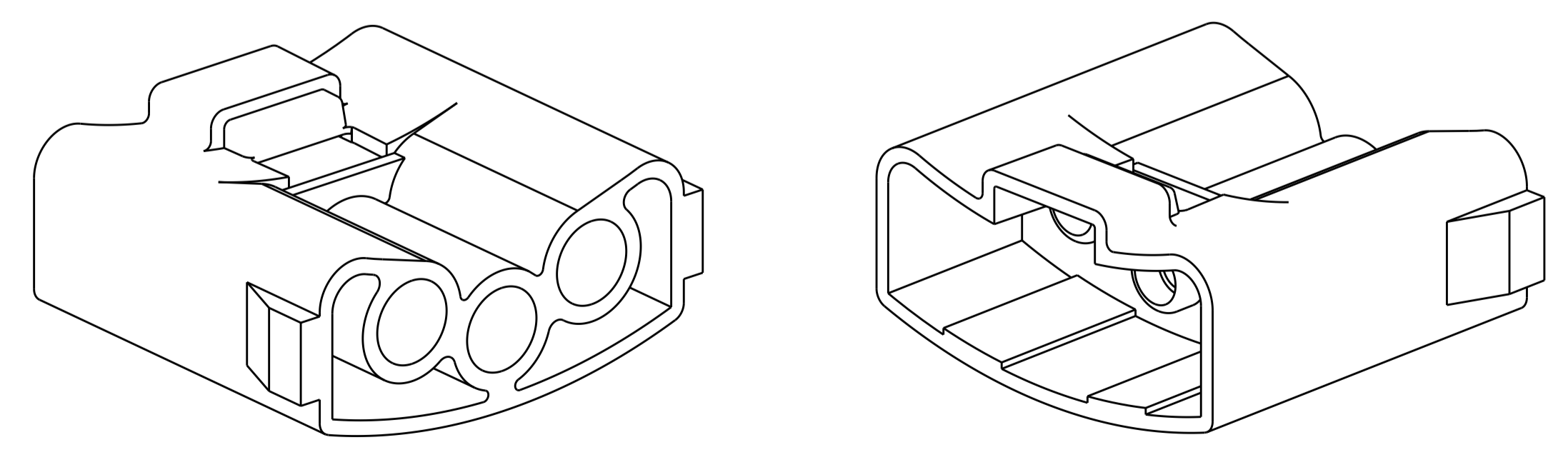
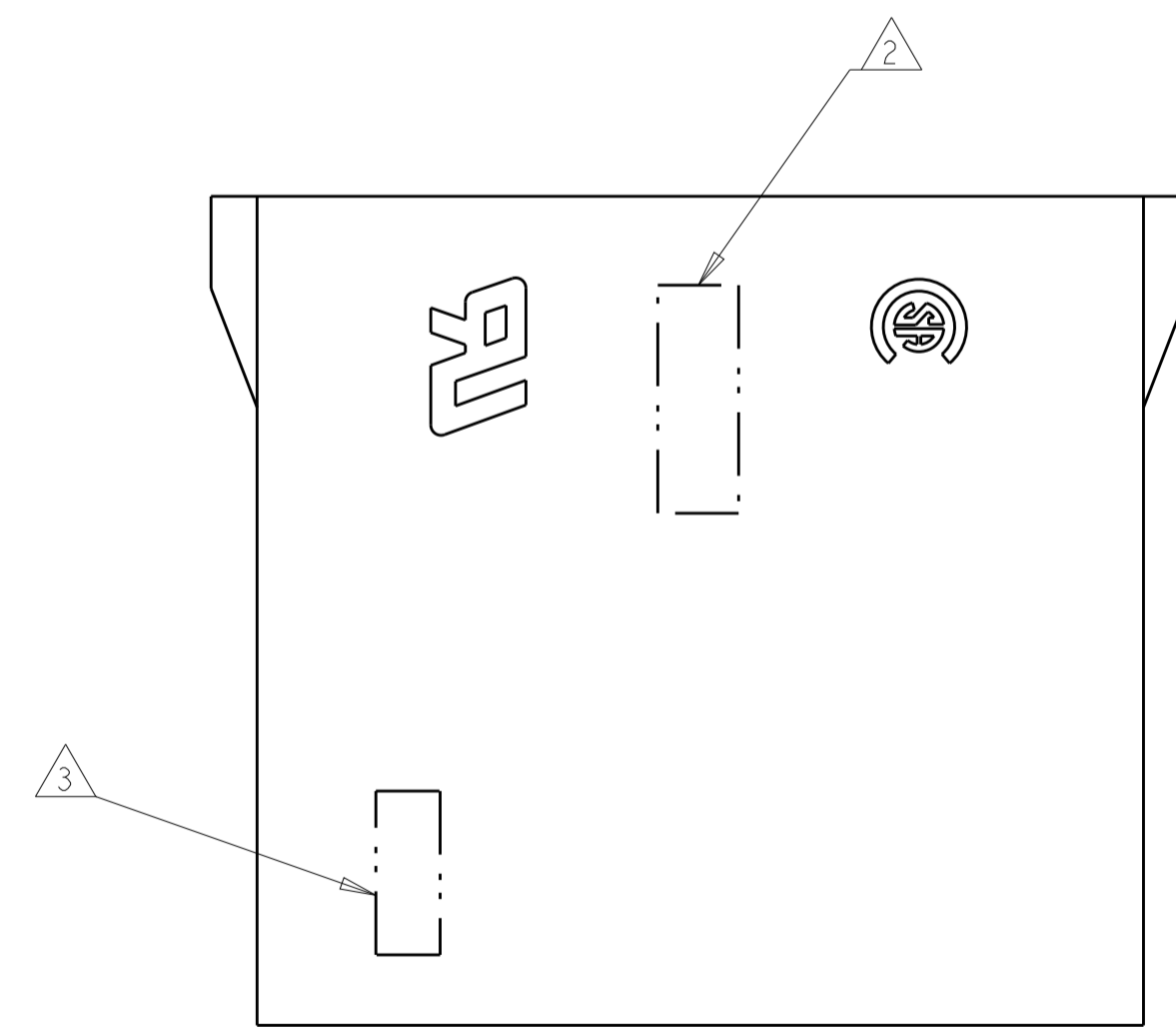
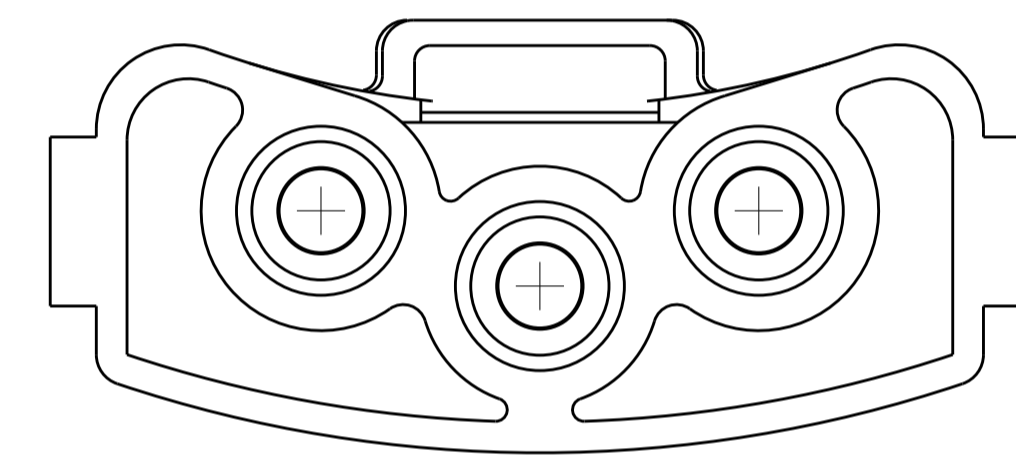
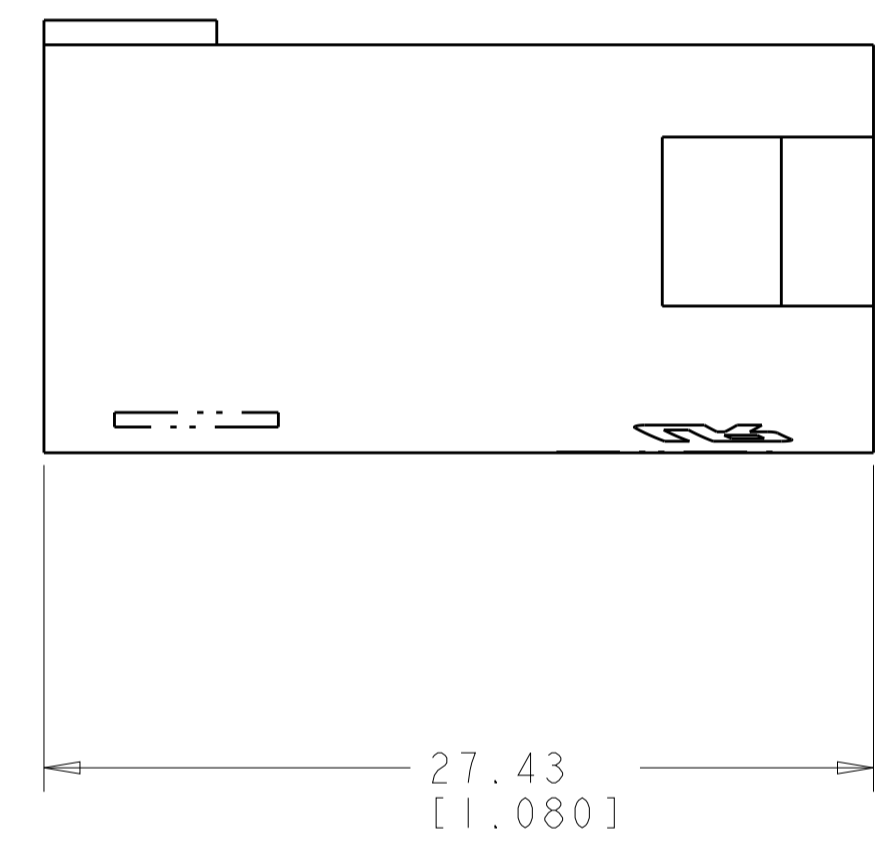
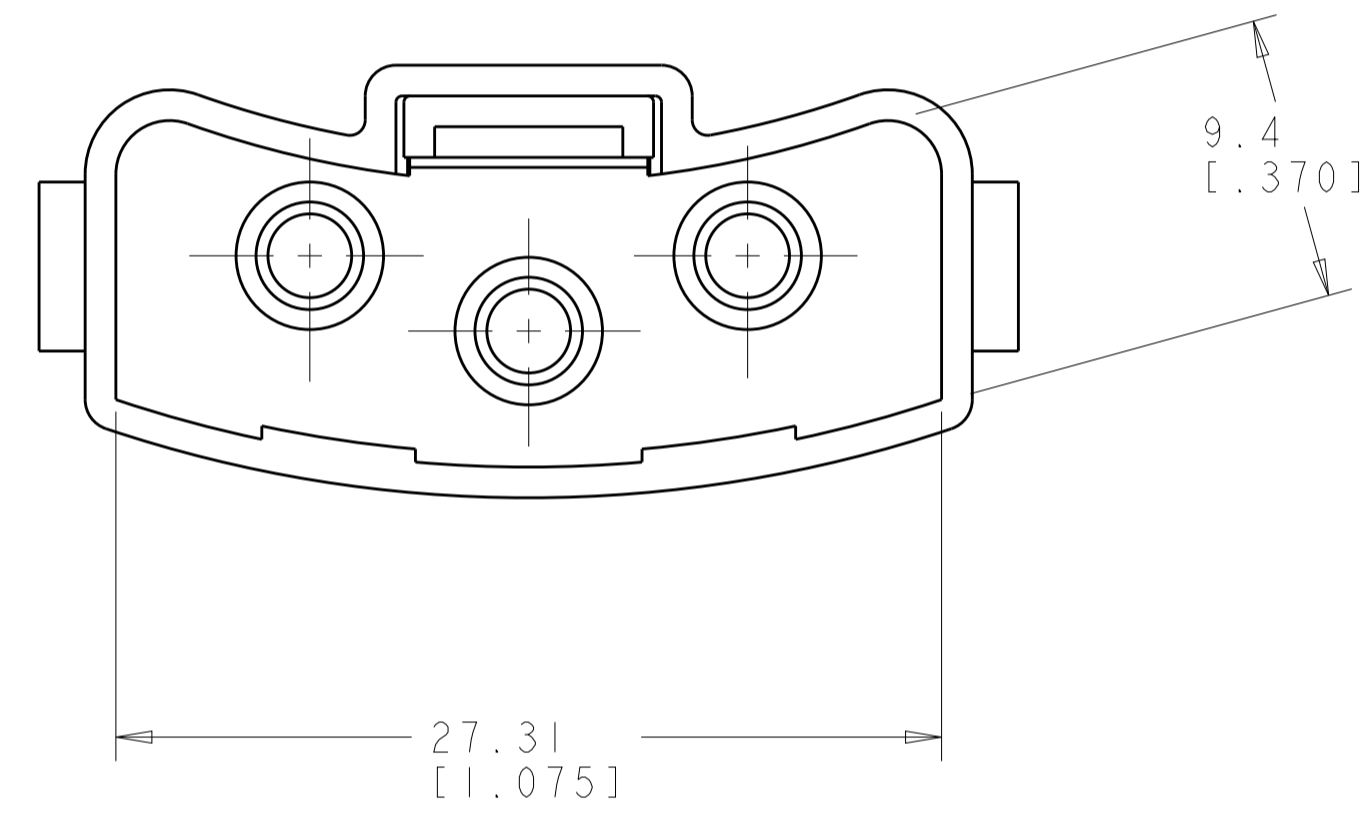

3 DIMENSIONAL VIEW  
SCALE 3:1

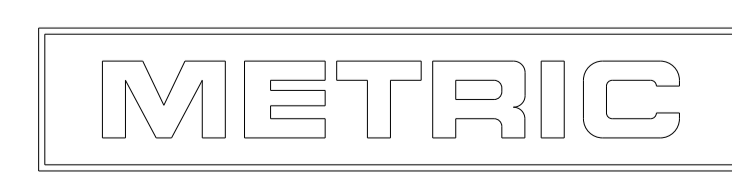

794099-1  
PART NUMBER

<small>THIS DRAWING IS UNPUBLISHED. RELEASED FOR PUBLICATION. IT IS THE POLICY OF TYCO ELECTRONICS CORPORATION TO CONTROL THE DISTRIBUTION OF THIS DRAWING TO THE EXTENT OF THE PROTECTION OF THE RIGHTS OF THE COMPANY. THIS DRAWING IS THE PROPERTY OF TYCO ELECTRONICS CORPORATION AND IS NOT TO BE REPRODUCED OR TRANSMITTED IN ANY FORM OR BY ANY MEANS, ELECTRONIC OR MECHANICAL, INCLUDING PHOTOCOPYING, RECORDING, OR BY ANY INFORMATION STORAGE AND RETRIEVAL SYSTEM, WITHOUT THE WRITTEN PERMISSION OF TYCO ELECTRONICS CORPORATION.</small>		DWN: R. WHITAKER 06DEC2001 CHK: S. RIDGILL 06DEC2001 APVD: S. RIDGILL 06DEC2001	<b>tyco</b> Electronics Tyco Electronics Harrisburg, PA 17105-3608
DIMENSIONS: mm [ INCHES ]	TOLERANCES UNLESS OTHERWISE SPECIFIED: 0 PLC ± 1 PLC ±.013 [ .005 ] 2 PLC ± 3 PLC ± 4 PLC ± ANGLES ± 40° 30'	NAME: HOUSING, 3 POSITION, FAN MOTOR CONNECTOR MATE, UNIVERSAL MATE-N-LOK(TM) PRODUCT SPEC: APPLICATION SPEC:	SIZE: A1 CAGE CODE: 00779 DRAWING NO: 794099 RESTRICTED TO:
MATERIAL: NYLON UL94V-2, NATURAL FINISH:	WEIGHT:	CUSTOMER DRAWING	SCALE: 4:1 SHEET 1 OF 1 REV: D2