

**SQUARE FLANGE JACK RECEPTACLE
WITH SHOULDER CONTACT**

R125.620.000

Series : SMA

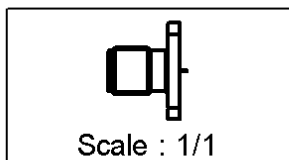
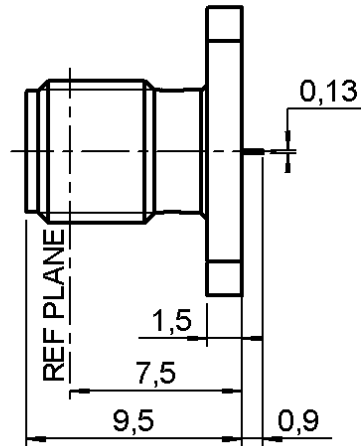
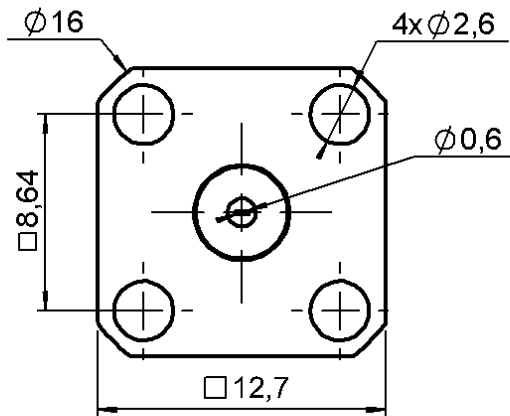

PANEL CUT OUT

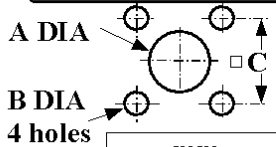

| | mm | |
|---|------|------|
| | Maxi | mini |
| A | 4.2 | 4.1 |
| B | 2.7 | 2.6 |
| C | 8.69 | 8.59 |

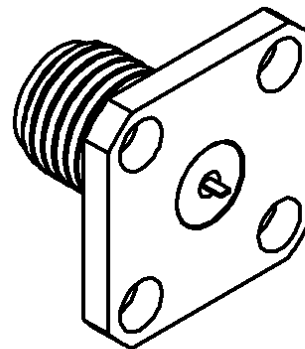

All dimensions are in mm.



| COMPONENTS | MATERIALS | PLATINGS (µm) |
|----------------|------------------|------------------------|
| BODY | STAINLESS STEEL | GOLD 0.5 OVER NICKEL 2 |
| CENTER CONTACT | BERYLLIUM COPPER | GOLD 1.3 OVER NICKEL 2 |
| OUTER CONTACT | - | - |
| INSULATOR | PTFE | - |
| GASKET | - | - |
| OTHERS PARTS | - | - |
| - | - | - |
| - | - | - |

Issue : 0223 F

In the effort to improve our products, we reserve the right to make changes judged to be necessary.



**SQUARE FLANGE JACK RECEPTACLE
WITH SHOULDER CONTACT**

R125.620.000

Series : SMA

PACKAGING

SPECIFICATION

| Standard | Unit | Other |
|------------|-------------------|-------------------|
| 100 | 'W' option | Contact us |

ELECTRICAL CHARACTERISTICS

ENVIRONMENTAL

| | | |
|---------------------------------|---------------|------------------------------|
| Impedance | | 50 Ω |
| Frequency | | 0-18 GHz |
| VSWR | 1.06 + | 0.002 x F(GHz) Maxi |
| Insertion loss | | 0.07* √F(GHz) dB Maxi |
| RF leakage | - (| 60 - F(GHz)) dB Maxi |
| Voltage rating | | 500 Veff Maxi |
| Dielectric withstanding voltage | | 1000 Veff mini |
| Insulation resistance | | 5000 MΩ mini |

| | |
|-----------------------|---------------------|
| Operating temperature | -65/+165 ° C |
| Hermetic seal | NA Atm.cm3/s |
| Panel leakage | NA |

OTHERS CHARACTERISTICS

Assembly instruction **NA**

Others :

* Coaxial Transmission Line Only

MECHANICAL CHARACTERISTICS

| | | |
|----------------------------|--------------|-------------|
| Center contact retention | | |
| Axial force – Mating end | 27 | N mini |
| Axial force – Opposite end | 27 | N mini |
| Torque | 2.8 | N.cm mini |
| Recommended torque | | |
| Mating | NA | N.cm |
| Panel nut | NA | N.cm |
| Mating life | 500 | Cycles mini |
| Weight | 2.544 | g |

Issue : 0223 F

In the effort to improve our products, we reserve the right to make changes judged to be necessary.

