

# OT Type 7.0 x 5.0 mm SMD LVPECL/LVDS/ HCSL Crystal Oscillator

## FEATURE

- Typical 7.0 x 5.0 x 1.45 mm hermetically sealed ceramic package.
- Very low jitter performance: typical 0.3 pS RMS from 12k-20MHz.
- Fundamental/3rd overtone crystal design.
- Output frequency up to 320 MHz.
- Operating temperature up to 125°C
- Tri-state enable/disable

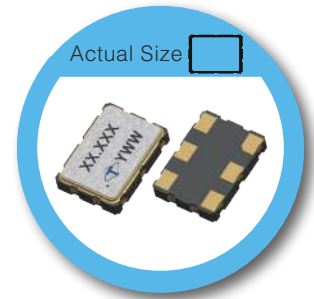

RoHS Compliant

## TYPICAL APPLICATION

- 10Gbit Ethernet, Fiber Channel, Storage Area Network, SONET
- Enterprise Servers, Reference clocks for ADC and DAC
- Telecom

## DIMENSION (mm)

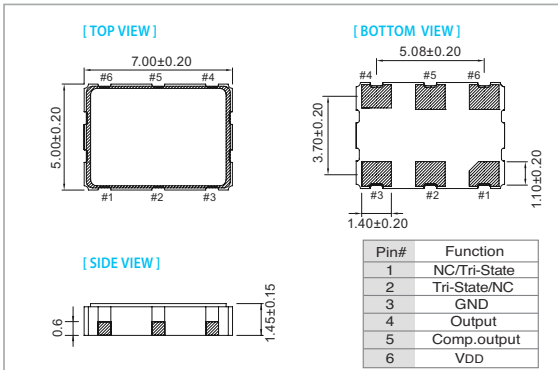

## SOLDER PAD LAYOUT (mm)

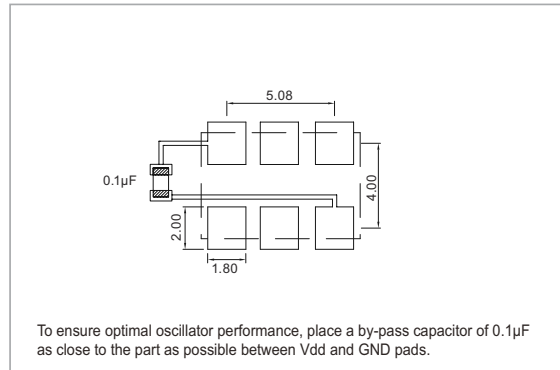

## ELECTRICAL SPECIFICATION

Parameter	LVPECL				LVDS				unit	
	3.3 V		2.5 V		3.3 V		2.5 V			
	Min.	Max.	Min.	Max.	Min.	Max.	Min.	Max.		
<b>Supply Voltage Variation (VDD)</b>	VDD-5%	VDD+5%	VDD-5%	VDD+5%	VDD-5%	VDD+5%	VDD-5%	VDD+5%	V	
<b>Frequency Range</b>	10	320	10	320	10	320	10	320	MHz	
<b>Standard Frequency</b>	77.76, 106.25, 125, 155.52, 156.25, 187.5, 212.5, 312.5									
<b>Supply Current</b>	10 MHz ≤ Fo < 160 MHz	—	75	—	75	—	50	—	50	mA
	160 MHz ≤ Fo < 250 MHz	—	100	—	100	—	50	—	50	
	250 MHz ≤ Fo ≤ 320 MHz	—	100	—	100	—	65	—	65	
<b>Output Level</b>	Output High	2.275	—	1.475	—	1.6	—	1.6	1.6	V
	Output Low	—	1.68	—	0.88	0.9	—	0.9	—	
<b>Transition Time: Rise/Fall Time<sup>+</sup></b>		—	1.0	—	1.0	—	1.0	—	1.0	nSec
<b>Start Time</b>		—	10	—	10	—	10	—	10	mSec
<b>Tri-State(Input to Pin 2 or Pin 1)</b>										
Enable (High voltage or floating)	2.31	—	1.75	—	2.31	—	1.75	—	—	V
Disable (Low voltage or GND)	—	0.99	—	0.75	—	0.99	—	0.75	—	
<b>RMS Phase Jitter (Integrated 12 KHz - 20 MHz)</b>										pSec
Fo < 80 MHz	—	1	—	1	—	1	—	1		
80 MHz ≤ Fo < 125 MHz	—	0.5	—	0.5	—	0.5	—	0.5		
125 MHz ≤ Fo < 170 MHz	—	0.3	—	0.3	—	0.3	—	0.3		
170 MHz ≤ Fo < 200 MHz	—	0.5	—	0.5	—	0.5	—	0.5		
200 MHz ≤ Fo	—	0.3	—	0.3	—	0.3	—	0.3		
<b>Phase Noise @ 156.25 MHz</b>	100Hz	-100		-100		-100		-100	dBc/Hz	
	1 kHz	-130		-130		-130		-130		
	10 kHz	-145		-145		-145		-145		
<b>Aging (@ 25°C 1st year)</b>		—	±3	—	±3	—	±3	—	±3	ppm
<b>Storage Temp. Range</b>		-55	125	-55	125	-55	125	-55	125	°C

Note: not all combination of options are available. Other specifications may be available upon request.

Parameter	HCSL				unit
	3.3 V		2.5 V		
	Min.	Max.	Min.	Max.	
<b>Supply Voltage Variation (VDD)</b>	VDD-5%	VDD+5%	VDD-5%	VDD+5%	V
<b>Frequency Range</b>	25	175	25	175	MHz
<b>Standard Frequency</b>	100				
<b>Supply Current</b> 25 MHz ≤ Fo ≤ 175 MHz	–	50	–	50	mA
<b>Output Level</b>					V
Output High	0.6	–	0.58	–	
Output Low	–	0.15	–	0.15	
<b>Transition Time: Rise/Fall Time+</b>	–	0.5	–	0.5	nSec
<b>Start Time</b>	–	10	–	10	mSec
<b>Tri-State(Input to Pin 2 or Pin 1)</b>					V
Enable	0.7VDD	–	0.7VDD	–	
Disable	–	0.3VDD	–	0.3VDD	
<b>RMS Phase Jitter (Integrated 12 kHz ~ 20 MHz)</b> 25MHz ≤ Fo ≤ 175MHz	–	0.5	–	0.5	pSec
<b>Aging</b>	–	±3	–	±3	ppm
<b>Storage Temp. Range</b>	-55	125	-55	125	°C

Standard frequencies are frequencies which the crystal has been designed and does not imply a stock position.

+ Transition times are measured between 20% and 80% of VDD.

### FREQ. STABILITY vs. TEMP. RANGE

Temp. (°C)	ppm	±25	±50
-10 ~ +60		○	○
-20 ~ +70		○	○
-40 ~ +85		△	○
-40 ~ +125		×	○

\* ○: Available △:Conditional X: Not available

\* Inclusive of calibration @ 25 °C, operating temperature range, input voltage variation, load variation, aging (1<sup>st</sup> year), shock, and vibration

**Note: not all combination of options are available. Other specifications may be available upon request.**

Specifications subject to change without notice.