

ATLANTIC VERSION TERMINATOR INTERFACE ADAPTER	PART NUMBER	REVISION	DESCRIPTION	FEED TYPE	
	2266201-1	B	FINE CRIMP HEIGHT ADJUST	MECHANICAL	SUPERSEDED BY 5-2266353-1
	2266201-2	B	FINE CRIMP HEIGHT ADJUST	PNEUMATIC	SUPERSEDED BY 5-2266353-2
	2266201-5	B	FINE CRIMP HEIGHT ADJUST	SERVO LATCH PLATE ⁴	OBSOLETE
	2266201-6	B	NON-CRIMP HEIGHT ADJUST	SERVO LATCH PLATE ⁴	OBSOLETE
	2266201-7	B	FINE CRIMP HEIGHT ADJUST	NONE	OBSOLETE
	7-2266201-7	A	CRIMP TOOLING KIT	-	

APPLICATOR DATA		
CRIMP	SIZE	TYPE
WIRE	1.93 mm [.076]	F
INSUL	3.94 mm [.155]	O

APPLICATOR INSTRUCTIONS
408-10389

TERMINAL DATA: KOSTAL TERMINAL	KOSTAL CRIMP SPECIFICATION
TERMINAL NAME: SLK 2.8 SWS	
WIRE STRIP LENGTH 4.00-4.60 mm [.157-.181 IN]	INSULATION DIAMETER RANGE Ø1.40-2.10 mm [.055-.083 IN]
TERMINAL APPLICATION SPECIFICATION DOC00074173 Rev 6	

TE TERMINAL	KOSTAL TERMINAL	TE SEAL	KOSTAL SEAL
1-957401-1	2 21 40 49206 0	957402-1	1 08 00 44452 2
1-957401-2	2 21 24 49206 0	2113422-1	10030680
2113421-1	2 21 25 49206 0		
2113421-2	1 01 40 49914 0		
2113421-3	1 01 24 49914 0		
2113421-4	1 01 25 49914 0		

WIRE SIZE	CRIMP HEIGHT mm [INCH]	CRIMP HEIGHT REFERENCE SETTING
1.00mm2	1.34+/-0.03 [.053+/-0.001]	4.0
0.75mm2	1.32+/-0.03 [.052+/-0.001]	4.1
0.50mm2	1.20+/-0.03 [.047+/-0.001]	5.4

- 1 RECOMMENDED SPARE PARTS
- 2 GREASE BEARING SURFACES LIGHTLY
- 3 LUBRICATE DAILY PER THE APPLICATOR INSTRUCTION SHEET SUPPLIED WITH THE APPLICATOR.
- 4 APPLICATOR SPECIFIC DATA TO BE ENTERED INTO BLANK MEMORY CHIP AT ASSEMBLY. SEE BELOW FOR PART NUMBER:
MECHANICAL FEED WITH "SMART APPLICATOR" CONVERSION: 8-2266201-4
PNEUMATIC FEED WITH "SMART APPLICATOR" CONVERSION: 8-2266201-4
SERVO FEED WITH "FINE CRIMP HEIGHT ADJUST": 8-2266201-5
SERVO FEED WITH "NON-CRIMP HEIGHT ADJUST": 8-2266201-6
- 5 ADJUSTMENT OF THE STRIPPER MAY BE REQUIRED WHEN MOVING THE APPLICATOR BETWEEN BENCH AND LEADMAKER APPLICATIONS.
- 6 APPLY PART NUMBER 1-23419-5 LOCTITE TO THREADS OF ITEMS 62 & 180. APPLY PART NUMBER 2-23419-6 LOCTITE TO THREADS OF ITEMS 242. FOR -6 ONLY APPLY PART NUMBER 1-23419-5 LOCTITE TO THREADS OF ITEM 37.
- 7 GREASE THREADS, GROOVE AND O-RING ON ITEMS 35 & 252.
- 8 MAGNET, ITEM 166 MUST BE ORIENTED CORRECTLY IN ORDER TO PROPERLY ACTUATE THE COUNTER.
- 9 CRIMP HEIGHT REFERENCE SETTING WAS THE SETTING USED WHEN THE APPLICATOR WAS QUALIFIED AT THE FACTORY. ADJUSTMENT MAY BE NECESSARY WHEN RUNNING APPLICATOR IN THE FIELD.
- 10 SPARE FEED CAM STORAGE LOCATION REFER TO INSTRUCTION SHEET FOR ADDITIONAL INFORMATION.
- 11 TO CONVERT THE APPLICATOR TO A NON-CARRIER CUTTING STYLE, REMOVE ITEM 13 AND ATTACH TO THE LOCATION ON THE BACK SIDE OF THE HOUSING. REFER TO INSTRUCTION SHEET FOR ADDITIONAL INFORMATION.
- 12 WHEN ASSEMBLING A NON CRIMP HEIGHT ADJUST APPLICATOR (-6) USE SHIMS FROM ITEM 260 TO ACHIEVE A NOMINAL SHIM HEIGHT OF 4.46.
- 13 THIS APPLICATOR APPLIES TERMINAL WITH A SEAL.
- 14 APPLY TORQ-SEAL IN ALLEN SOCKET TO FILL HOLE AFTER FLAT HD HAS BEEN ADJUSTED TO CORRECT HEIGHT AT QUALIFICATION. APPLY #1-23419-5 LOC-TITE TO THREADS.
- 15 THIS APPLICATOR IS SPECIFIC FOR USE IN A STRIPPER SEAL TERMINATING UNIT.
- 16 TERMINAL LUBRICANT IS RECOMMENDED.

***WARNING**
ON INSTALLATION, SET WIRE DISC, ITEM 40 TO LARGEST WIRE SIZE SETTING. USE OF SETTINGS BELOW MINIMUM REQUIRED CRIMP HEIGHT SETTING WILL CAUSE DAMAGE TO CRIMP TOOLING.

ITEM NO	DESCRIPTION	ITEM NO
260	APPLICATOR SHIM PACK	260
252	O-RING, .676 ID, .070 DIA. MAT.	252
250	PUSH ROD, AIR FEED	250
249	BUSHING, LCH5-12, MISUMI	249
248	FEED CAM, AIR FEED	248
247	DETENT PIN	247
246	SPRING, COMPRESSION	246
245	RAM, AMP STYLE, SIDE FEED, NON-ADJ.	245
244	CAM, SNAIL, INSULATION ADJUSTMENT	244
243	WASHER, WAVE SPRING, CREST-TO-CREST	243
242	RETAINER, INSULATION DIAL	242
ITEM NO	DESCRIPTION	ITEM NO

ATLANTIC VERSION
Shown on sheets 1 of 4 & 2 of 4
(Pacific version shown on sheets 3 of 4 & 4 of 4)

SET UP GAUGE	LOC	DIST	REVISIONS			
2119599-1	A	66	#	DATE	BY	APPV
			A	RELEASED	11FEB2014	KH UG
			B	ECR-16-018122	22DEC2016	KH TE
			B1	ECR-18-009449	19JUN2018	LG JD

ITEM NO	DESCRIPTION	DATE	BY	APPV
- 1 1 1 1 1	7-18023-7	SCR, SKT HD CAP M3 X 4.0		241
- - 2 2 - -	2168400-6	SHCS, LOW HEAD, RoHS, M5 X 16		240
- - - - - 1	2119580-1	MECHANICAL FEED ASSEMBLY		239
- - - - - 1	2063440-1	AIR FEED MODULE		238
- - 1 1 - -	2119740-2	TAG, IDENTIFICATION		213
- - 1 1 - -	1901094-3	SPACER, FEEDER		198
- 1 1 1 1 1	4-1722335-3	STRIPPER, SIDE FEED		182
- 1 1 1 1 1	1-5018030-0	NUT, HEX, REG, RoHS, M3.5		181
- 1 1 1 1 1	1-1752354-8	STANDOFF, HOLD-DOWN		180
- 1 1 1 1 1	993111-1	PIN, SLOTTED SPRING 3.0 X 20.0		177
- 1 1 1 1 1	5-22280-0	SPRING, COMPRESSION		176
- 1 1 1 1 1	1752353-3	GUIDE PIN, HOLDDOWN		175
- 1 1 1 1 1	1901680-2	GUIDE PIN, HOLDDOWN		174
- - - - - 2	21045-3	RING, RETAIN, EXTERN, 3/16 CRESCENT		172
- 1 1 1 1 1	994969-1	MAGNET, RARE EARTH HIGH ENERGY		166
- REF REF REF REF REF	994970-2	COUNTER, MAGNETIC		164
- - - - - 1	240638-1	SPRING, FEED FINGER		163
- - - - - 1	3-23627-7	PIN, RETAIN, GRVD, 3/16 X .854		137
- - - - - 1	2119799-1	HOLDER, FEED FINGER, AF		136
- - REF REF - -	SEE NOTE 4	MEMORY CHIP, PROGRAMMED		135
- - 1 1 - -	1633743-1	SERVO FEED LATCH ASM		133
- 1 1 1 1 1	1-18028-2	WASHER, FLAT, REG M4		119
- - REF REF - -	2119944-1	FEED FINGER ASSEMBLY, SF		117
- 1 1 1 1 1	2119955-1	ASSY, LUBRICATOR, SIDE FEED		113
- 1 1 1 1 1	455888-5	SPACER, CRIMPER		82
- 1 1 1 1 1	2119956-1	DOCUMENTATION PACKAGE		71
- 1 1 1 1 1	2119791-9	DEPRESSOR, WIRE		70
- 1 1 1 1 1	2119943-1	WASHER, SPACER		69
- 1 - - 1 1	2119740-1	TAG, IDENTIFICATION		67
- 2 2 2 2 2	2168078-1	SCREW, DRIVE, RH, RoHS, 2 x .188		66
- 1 - 1 1 1	2119793-1	LIMITER, ADJUSTMENT BOLT		63
- 3 - 3 3 3	992763-5	SCR, SET, SOC, CONE PNT, M3 x 4.0		62
- 1 1 1 1 1	2079383-4	SCR, BHSC, RoHS (M4 X 8)		60
- - - - - 1	5-18022-5	SCR, HEX HD CAP, M4 X 6.0		59
- 1 1 1 1 1	985575-3	SCR, FLT SKT HD CAP M3 X 10.0		57
- - - - - 1	1338685-1	PAWL, FEED		56
- 4 4 4 4 4	2168400-1	SHCS, LOW HEAD, RoHS, M4 X 12		54
- 2 2 2 2 2	2168083-8	SCR, SKT HD CAP, RoHS, M4 X 16		53
- 1 1 1 1 1	5018030-1	NUT, HEX, REG, RoHS, M3		52
- 1 1 1 1 1	811242-5	BUMPER, HOLD DOWN		51
- 1 1 1 1 1	690753-2	SPACER, TONKER		50
- - - - - 1	18023-9	SCR, SKT HD CAP M4 X 6.0		49
- - - - - 1	2119652-1	FEED CAM, PRE FEED		48
- - - - - 1	2119653-1	FEED CAM, POST FEED		47
- 1 1 1 1 1	2-2119656-1	APPLICATOR BASIC ASSEMBLY, SF		46
- 1 - 1 1 1	2119370-1	RAM, AMP STYLE, SIDE FEED		44
- 1 1 1 1 1	2079383-7	SCR, BHSC, RoHS (M8 X 25)		41
- 1 - 1 1 1	2119645-1	DISC, NUMBERED FA WIRE ADJUSTMENT		40
- 1 - 1 1 1	2119957-1	APPLICATOR SHIM PACK		39
- 1 1 1 1 1	2119644-1	RAM WASHER, PRECISION		38
- 1 1 1 1 1	2119085-1	FA HEAD, ATLANTIC STYLE		37
- 1 - 1 1 1	2119092-1	BOLT, ADJUSTMENT		35
- 1 1 1 1 1	1752356-3	SUPPORT, TERMINAL		34
- 2 2 2 2 2	2079383-5	SCR, BHSC, RoHS (M4 X 20)		33
- 1 1 1 1 1	2161328-1	HEX HEAD, FLANGED, M5 x 8mm LONG		32
- 1 1 1 1 1	1-1320908-2	SPACER, STRIP GUIDE		30
- 1 1 1 1 1	2119959-4	ASSEMBLY, STRIP GUIDE		29
- 1 1 1 1 1	455888-3	SPACER, CRIMPER		28
- 1 1 1 1 1	240792-1	DRAG, TERMINAL		25
- 1 1 1 1 1	1320928-2	STRIP GUIDE		24
- 1 1 1 1 1	2119806-1	INSERT, SHEAR		13
- 1 1 1 1 1	3-22280-3	SPRING, COMPRESSION		12
- 1 1 1 1 1	1-356885-4	STOP, SHEAR		11
- 1 1 1 1 1	2119805-1	SHEAR HOLDER, FRONT		10
- 1 1 1 1 1	318707-1	FLOATING SHEAR, FRONT		9
1 1 1 1 1 1	7-1633927-4	ANVIL, COMBINATION		8
- 1 1 1 1 1	1-240641-4	SPACER		7
- - - - -	-	-		6
- 1 1 1 1 1	2119781-1	DEPRESSOR, SHEAR		5
- 1 1 1 1 1	238011-4	BLOCK, CRIMPER SPACER		4
1 1 1 1 1 1	2-2119784-9	CRIMPER, INSULATION O PREMIUM		3
- 1 1 1 1 1	455888-8	SPACER, CRIMPER		2
1 1 1 1 1 1	5-1490019-4	CRIMPER, WIRE PREMIUM		1
ITEM NO	DESCRIPTION	ITEM NO		

DIMENSIONS:	TOLERANCES UNLESS OTHERWISE SPECIFIED:	DATE	NAME
mm	0 PLC ± 1 PLC ± 2 PLC ± 3 PLC ± 4 PLC ± ANGLES ±	26 JAN 2014	H. HUANG
		26 JAN 2014	L. ZHANG
		26 JAN 2014	U. GUO
MATERIAL:	FINISH:	WEIGHT:	SCALE: 1:2
			SHEET 1 OF 4

REVISONS		DATE	OWN	APVD
LOC	DIST			
A	66			
P	LYR	DESCRIPTION		
-	-	SEE SHEET 1	-	-

FEED TYPE MECHANICAL

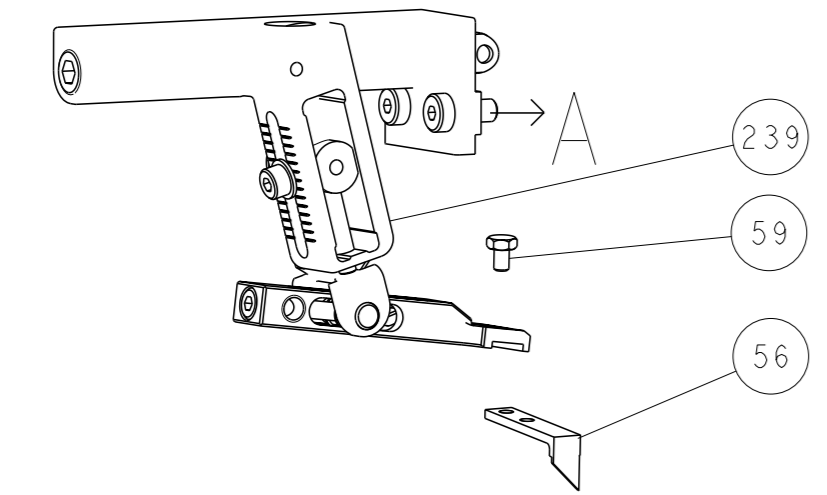

PNEUMATIC

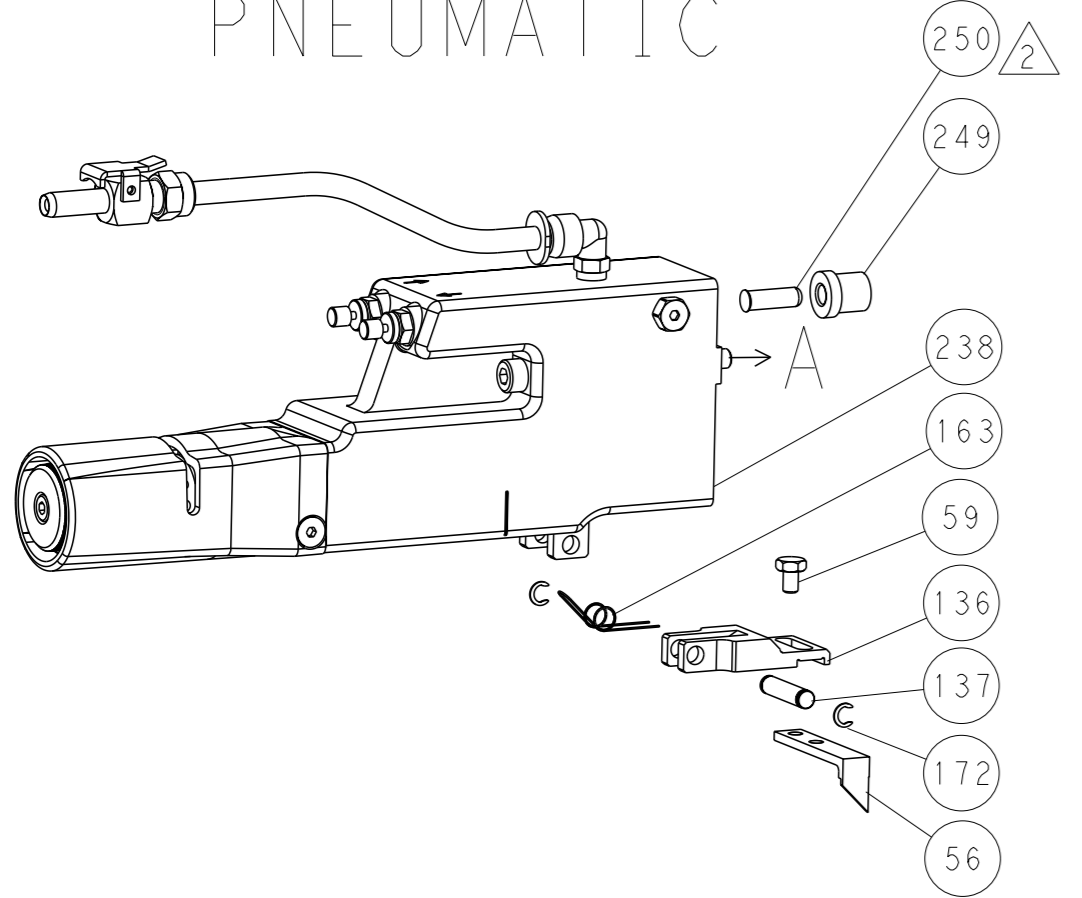

SERVO LATCH PLATE

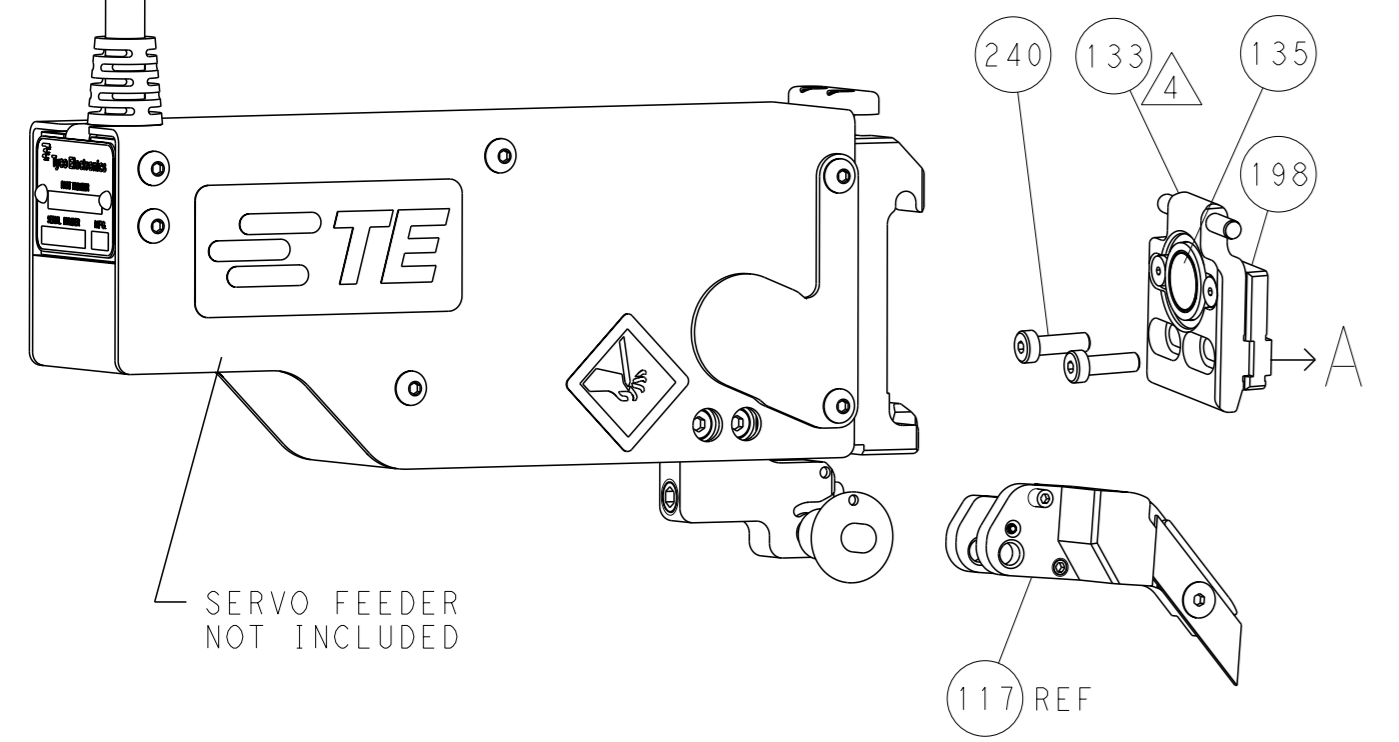

CAM POSITIONS

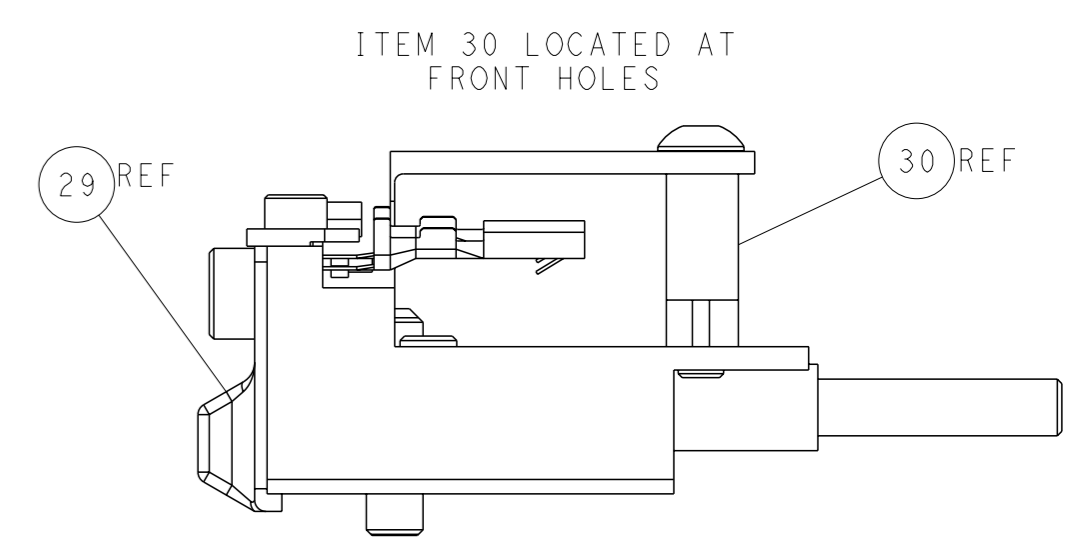
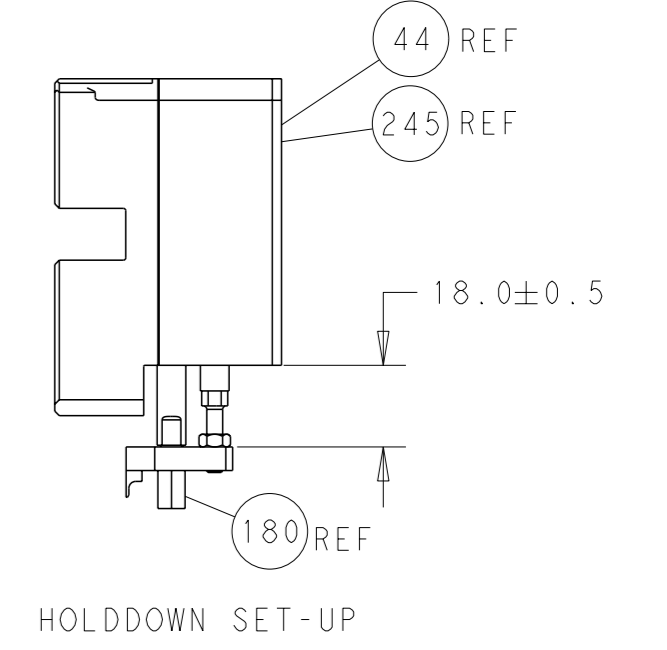
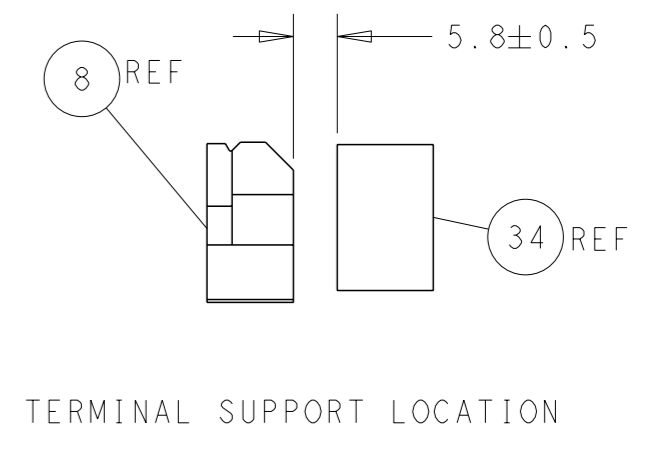
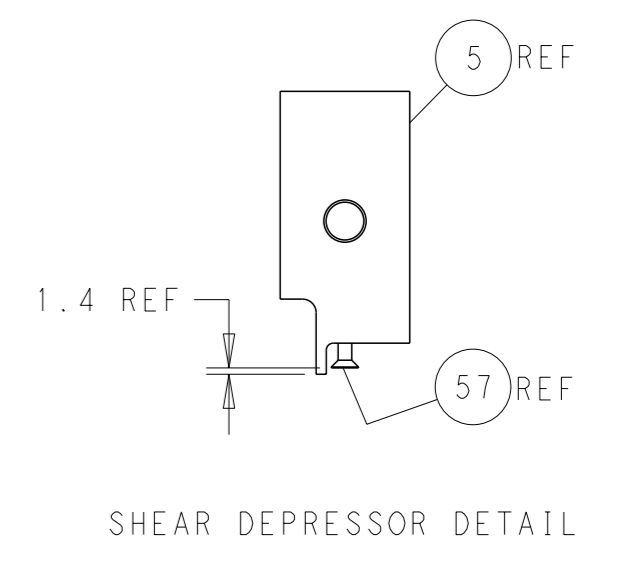
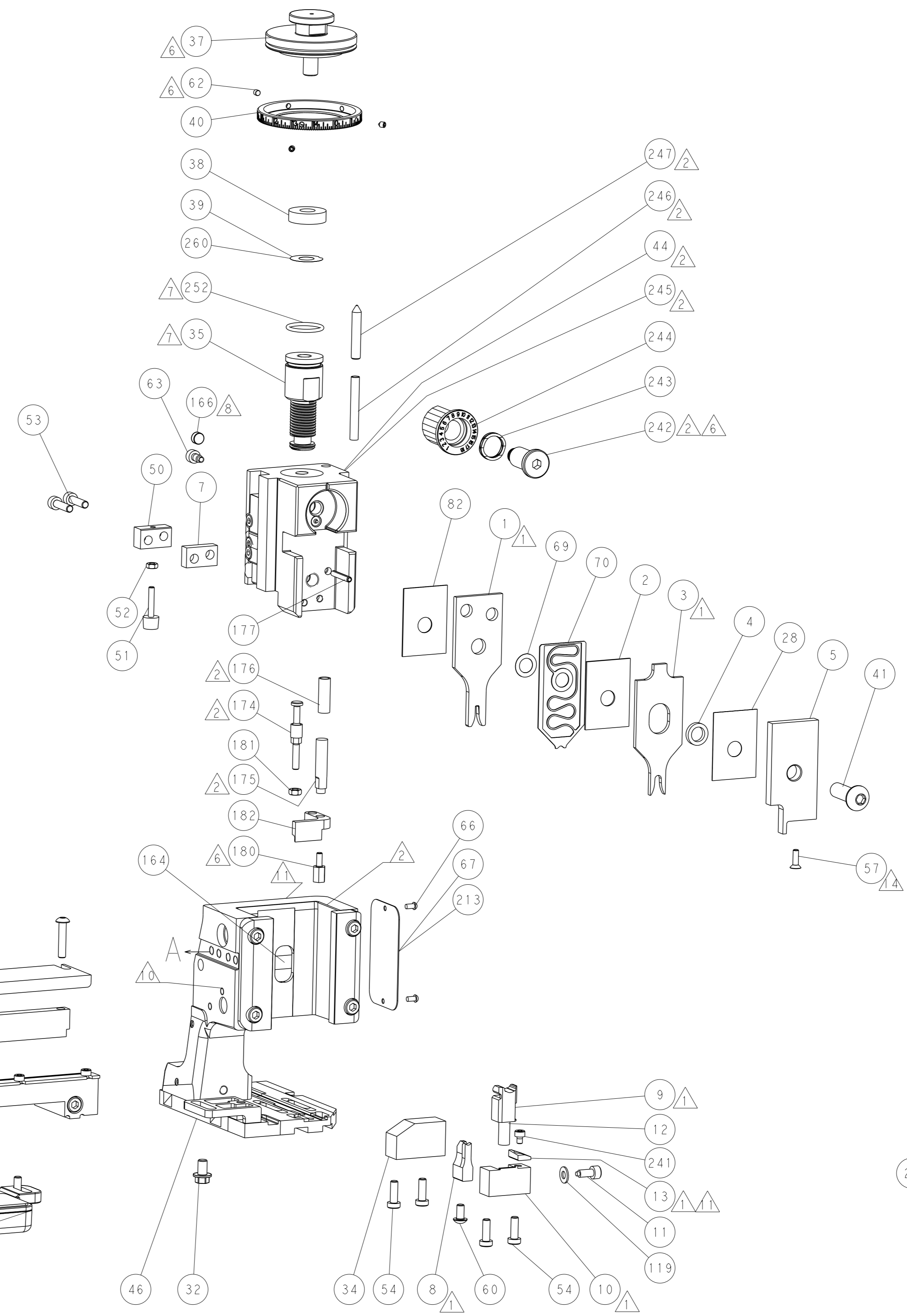
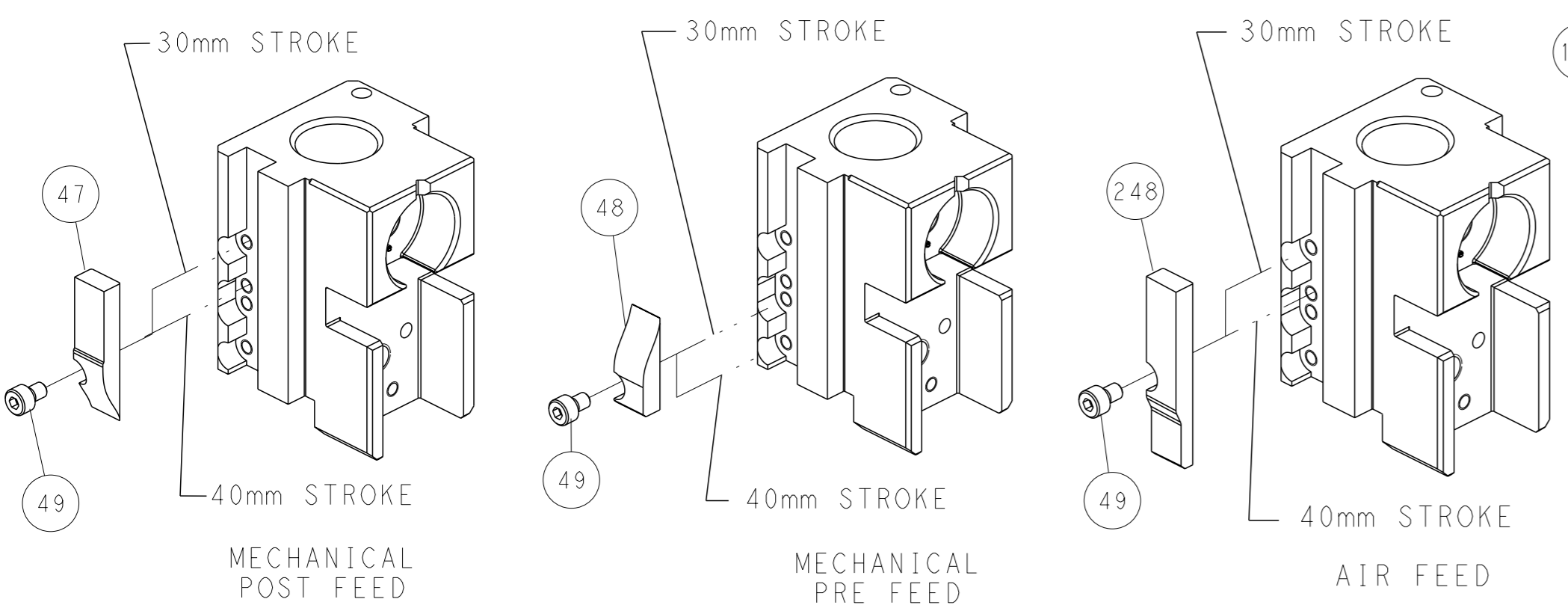

ATLANTIC VERSION
 Shown on sheets 1 of 4 & 2 of 4
 (Pacific version shown on sheets 3 of 4 & 4 of 4)

<small>THIS DRAWING IS UNPUBLISHED. RELEASED FOR PUBLICATION BY TYCO ELECTRONICS CORPORATION. ALL RIGHTS RESERVED.</small>		OWN: H. HUANG CHK: L. ZHANG APVD: J. GUO	DATE: 26 JAN 2014 DATE: 26 JAN 2014 DATE: 26 JAN 2014	NAME: Ocean Side Feed Applicator	TE Connectivity Harrisburg, PA 17105-3608
DIMENSIONS: mm TOLERANCES UNLESS OTHERWISE SPECIFIED: 0 PLC ± 1 PLC ± 2 PLC ± 3 PLC ± 4 PLC ± ANGLES FINISH ±		PRODUCT SPEC APPLICATION SPEC WEIGHT SCALE: 1:2	CAGE CODE: A1100779 DRAWING NO: C=2266201 SHEET 2 OF 4	RESTRICTED TO: - REV: B1	SHEETS 3 & 4 ARE NOT REQUIRED FOR ATLANTIC VERSION

PACIFIC VERSION TERMINATOR INTERFACE ADAPTER	PART NUMBER	REVISION	DESCRIPTION	FEED TYPE	
	2-2266201-1	B	FINE CRIMP HEIGHT ADJUST	MECHANICAL	OBSOLETE
	2-2266201-2	B	FINE CRIMP HEIGHT ADJUST	PNEUMATIC	OBSOLETE
	2-2266201-5	B	FINE CRIMP HEIGHT ADJUST	SERVO LATCH PLATE	OBSOLETE
	2-2266201-7	B	FINE CRIMP HEIGHT ADJUST	NONE	OBSOLETE
	7-2266201-7	A	CRIMP TOOLING KIT	-	

APPLICATOR DATA		
CRIMP	SIZE	TYPE
WIRE	1.93 mm [.076]	F
INSUL	3.94 mm [.155]	O
APPLICATOR INSTRUCTIONS 408-10389		

TERMINAL DATA: KOSTAL TERMINAL		KOSTAL CRIMP SPECIFICATION	
TERMINAL NAME: SLK 2.8 SWS			
WIRE STRIP LENGTH 4.00-4.60 mm [1.57-.181 IN]		INSULATION DIAMETER RANGE Ø1.40-2.10 mm [.055-.083 IN]	
TERMINAL APPLICATION SPECIFICATION DOC00074173 Rev 6			
TERMINALS APPLIED			
TE TERMINAL	KOSTAL TERMINAL	TE SEAL	KOSTAL SEAL
1-957401-1	2 21 40 49206 0	957402-1	1 08 00 44452 2
1-957401-2	2 21 24 49206 0	2113422-1	10030680
2113421-1	2 21 25 49206 0		
2113421-2	1 01 40 49914 0		
2113421-3	1 01 24 49914 0		
2113421-4	1 01 25 49914 0		

WIRE SIZE	CRIMP HEIGHT mm [INCH]	CRIMP HEIGHT REFERENCE SETTING
1.00mm2	1.34+/-0.03 [.053+/- .001]	4.0
0.75mm2	1.32+/-0.03 [.052+/- .001]	4.1
0.50mm2	1.20+/-0.03 [.047+/- .001]	5.4

- RECOMMENDED SPARE PARTS
- GREASE BEARING SURFACES LIGHTLY
- LUBRICATE DAILY PER THE APPLICATOR INSTRUCTION SHEET SUPPLIED WITH THE APPLICATOR.
- APPLICATOR SPECIFIC DATA TO BE ENTERED INTO BLANK MEMORY CHIP AT ASSEMBLY. SEE BELOW FOR PART NUMBER:
MECHANICAL FEED WITH "SMART APPLICATOR" CONVERSION: 8-2266201-4
PNEUMATIC FEED WITH "SMART APPLICATOR" CONVERSION: 8-2266201-5
SERVO FEED WITH "FINE CRIMP HEIGHT ADJUST": 8-2266201-5
- ADJUSTMENT OF THE STRIPPER MAY BE REQUIRED WHEN MOVING THE APPLICATOR BETWEEN BENCH AND LEADMAKER APPLICATIONS.
- APPLY PART NUMBER 1-23419-5 LOCTITE TO THREADS OF ITEMS 62 & 180.
APPLY PART NUMBER 2-23419-6 LOCTITE TO THREADS OF ITEMS 242.
- GREASE THREADS, GROOVE AND O-RING ON ITEMS 139 & 152.
- MAGNET MUST BE ORIENTED CORRECTLY IN ORDER TO PROPERLY ACTUATE THE COUNTER.
- CRIMP HEIGHT REFERENCE SETTING WAS THE SETTING USED WHEN THE APPLICATOR WAS QUALIFIED AT THE FACTORY. ADJUSTMENT MAY BE NECESSARY WHEN RUNNING APPLICATOR IN THE FIELD.
- SPARE FEED CAM STORAGE LOCATION REFER TO INSTRUCTION SHEET FOR ADDITIONAL INFORMATION.
- TO CONVERT THE APPLICATOR TO A NON-CARRIER CUTTING STYLE, REMOVE ITEM 13 AND ATTACH TO THE LOCATION ON BACK SIDE OF THE HOUSING. REFER TO INSTRUCTION SHEET FOR ADDITIONAL INFORMATION.
- THIS APPLICATOR APPLIES TERMINAL WITH A SEAL.
- APPLY TORQ-SEAL IN ALLEN SOCKET TO FILL HOLE AFTER FLAT HD HAS BEEN ADJUSTED TO CORRECT HEIGHT AT QUALIFICATION. APPLY #1-23419-5 LOC-TITE TO THREADS.
- THIS APPLICATOR IS SPECIFIC FOR USE IN A STRIPPER SEAL TERMINATING UNIT.
- TERMINAL LUBRICANT IS RECOMMENDED.

***WARNING**
ON INSTALLATION, SET WIRE DISC, ITEM 40 TO LARGEST WIRE SIZE SETTING. USE OF SETTINGS BELOW MINIMUM REQUIRED CRIMP HEIGHT SETTING WILL CAUSE DAMAGE TO CRIMP TOOLING.

-	1	1	1	1	2119782-1	FINE ADJUST HEAD ASM, PACIFIC STYLE	251
-	-	-	1	-	2119640-1	PUSH ROD, AIR FEED	250
-	-	-	1	-	2079988-1	BUSHING, LCH5-12, MISUMI	249
-	1	1	1	1	1-22279-3	SPRING, COMPRESSION	246
-	1	1	1	1	2119082-7	CAM, SNAIL, INSULATION ADJUSTMENT	244
-	1	1	1	1	2079764-1	WASHER, WAVE SPRING, CREST-TO-CREST	243
-	1	1	1	1	2119083-1	RETAINER, INSULATION DIAL	242
-	1	1	1	1	7-18023-7	SCR, SKT HD CAP M3 X 4.0	241
-	-	2	-	-	2168400-6	SHCS, LOW HEAD, RoHS, M5 X 16	240
-77	-27	-25	-22	-21	PART NO	DESCRIPTION	ITEM NO

PACIFIC VERSION
Shown on sheets 3 of 4 & 4 of 4
(Atlantic version shown on sheets 1 of 4 & 2 of 4)

SET UP GAUGE		LOC	DIST	REVISIONS					
2119599-1		A	66	P	LYR	DESCRIPTION	DATE	OWN	APVD
				-	-	SEE SHEET 1	-	-	-

-	-	-	-	1	2119580-1	MECHANICAL FEED ASSEMBLY	239
-	-	-	1	-	2063440-1	AIR FEED MODULE	238
-	-	1	-	-	2119740-2	TAG, IDENTIFICATION	213
-	-	1	-	-	1901094-3	SPACER, FEEDER	198
-	1	1	1	1	4-1722335-3	STRIPPER, SIDE FEED	182
-	1	1	1	1	1-5018030-0	NUT, HEX, REG, RoHS, M3.5	181
-	1	1	1	1	1-1752354-8	STANDOFF, HOLD-DOWN	180
-	1	1	1	1	993111-1	PIN, SLOTTED SPRING 3.0 X 20.0	177
-	1	1	1	1	5-22280-0	SPRING, COMPRESSION	176
-	1	1	1	1	1901680-2	GUIDE PIN, HOLDDOWN	175
-	1	1	1	1	1752353-3	GUIDE PIN, HOLDDOWN	174
-	-	-	2	-	21045-3	RING, RETAIN, EXTERN, 3/16 CRESCENT	172
-	1	1	1	1	994969-1	MAGNET, RARE EARTH HIGH ENERGY	166
-	REF	REF	REF	REF	994970-2	COUNTER, MAGNETIC	164
-	-	-	1	-	240638-1	SPRING, FEED FINGER	163
-	1	1	1	1	8-21084-1	O-RING, .801 ID, .070 DIA. MAT.	152
-	-	-	1	-	2119641-2	FEED CAM, AIR FEED	151
-	1	1	1	1	2119798-2	DETENT PIN	145
-	1	1	1	1	2079383-8	SCR, BHSC, RoHS (M4 X 16)	144
-	4	4	4	4	2168400-5	SHCS, LOW HEAD, RoHS, M4 X 20	143
-	-	-	-	1	2119653-2	FEED CAM, POST FEED	142
-	1	1	1	1	2-2119656-2	APPLICATOR BASIC ASSEMBLY, SF	141
-	1	1	1	1	2119650-1	RAM, ASIAN STYLE, SIDE FEED	140
-	1	1	1	1	2119092-2	BOLT, ADJUSTMENT	139
-	-	-	1	-	3-23627-7	PIN, RETAIN, GRVD, 3/16 X .854	137
-	-	-	1	-	2119799-1	HOLDER, FEED FINGER, AF	136
-	-	REF	-	-	SEE NOTE 4	MEMORY CHIP, PROGRAMMED	135
-	-	1	-	-	1633743-1	SERVO FEED LATCH ASM	133
-	1	1	1	1	1-18028-2	WASHER, FLAT, REG M4	119
-	-	REF	-	-	2119944-1	FEED FINGER ASSEMBLY, SF	117
-	1	1	1	1	2119955-1	ASSY, LUBRICATOR, SIDE FEED	113
-	1	1	1	1	455888-5	SPACER, CRIMPER	82
-	1	1	1	1	2119956-1	DOCUMENTATION PACKAGE	71
-	1	1	1	1	2119791-9	DEPRESSOR, WIRE	70
-	1	1	1	1	2119943-1	WASHER, SPACER	69
-	1	-	1	1	2119740-1	TAG, IDENTIFICATION	67
-	2	2	2	2	2168078-1	SCREW, DRIVE, RH, RoHS, 2 x .188	66
-	1	1	1	1	2119793-1	LIMITER, ADJUSTMENT BOLT	63
-	3	3	3	3	992763-5	SCR, SET, SOC, CONE PNT, M3 X 4.0	62
-	-	-	1	1	5-18022-5	SCR, HEX HD CAP, M4 X 6.0	59
-	1	1	1	1	985575-3	SCR, FLT SKT HD CAP M3 X 10.0	57
-	-	-	1	1	1338685-1	PAWL, FEED	56
-	2	2	2	2	2168083-8	SCR, SKT HD CAP, RoHS, M4 X 16	53
-	1	1	1	1	5018030-1	NUT, HEX, REG, RoHS, M3	52
-	1	1	1	1	811242-5	BUMPER, HOLD DOWN	51
-	1	1	1	1	690753-2	SPACER, TONKER	50
-	-	-	1	2	18023-9	SCR, SKT HD CAP M4 X 6.0	49
-	-	-	-	1	2119652-1	FEED CAM, PRE FEED	48
-	1	1	1	1	2079383-7	SCR, BHSC, RoHS (M8 X 25)	41
-	1	1	1	1	2119645-1	DISC, NUMBERED FA WIRE ADJUSTMENT	40
-	1	1	1	1	2119957-1	APPLICATOR SHIM PACK	39
-	1	1	1	1	2119644-1	RAM WASHER, PRECISION	38
-	1	1	1	1	1752356-3	SUPPORT, TERMINAL	34
-	2	2	2	2	2079383-5	SCR, BHSC, RoHS (M4 X 20)	33
-	1	1	1	1	2161328-1	HEX HEAD, FLANGED, M5 X 8mm LONG	32
-	1	1	1	1	1-1320908-2	SPACER, STRIP GUIDE	30
-	1	1	1	1	2119959-4	ASSEMBLY, STRIP GUIDE	29
-	1	1	1	1	455888-3	SPACER, CRIMPER	28
-	1	1	1	1	240792-1	DRAG, TERMINAL	25
-	1	1	1	1	1320928-2	STRIP GUIDE	24
-	1	1	1	1	2119806-1	INSERT, SHEAR	13
-	1	1	1	1	3-22280-3	SPRING, COMPRESSION	12
-	1	1	1	1	1-356885-4	STOP, SHEAR	11
-	1	1	1	1	2119805-1	SHEAR HOLDER, FRONT	10
-	1	1	1	1	318707-1	FLOATING SHEAR, FRONT	9
-	1	1	1	1	7-1633927-4	ANVIL, COMBINATION	8
-	1	1	1	1	1-240641-4	SPACER	7
-	-	-	-	-	-	-	6
-	1	1	1	1	2119781-1	DEPRESSOR, SHEAR	5
-	1	1	1	1	238011-4	BLOCK, CRIMPER SPACER	4
-	1	1	1	1	2-2119784-9	CRIMPER, INSULATION O PREMIUM	3
-	1	1	1	1	455888-8	SPACER, CRIMPER	2
-	1	1	1	1	5-1490019-4	CRIMPER, WIRE PREMIUM	1
-77	-27	-25	-22	-21	PART NO	DESCRIPTION	ITEM NO

DIMENSIONS:		TOLERANCES UNLESS OTHERWISE SPECIFIED:		NAME	
mm	0 PLC ±	1 PLC ±	2 PLC ±	3 PLC ±	4 PLC ±
	ANGLES FINISH	-			
MATERIAL		WEIGHT		SCALE	1:2
Customer Accessible Production Drawing		SCALE		SHEET	3 of 4



LOC	DIST	REVISIONS			
A	66	REV	DATE	OWN	APVD
		1	SEE SHEET 1		

FEED TYPE MECHANICAL

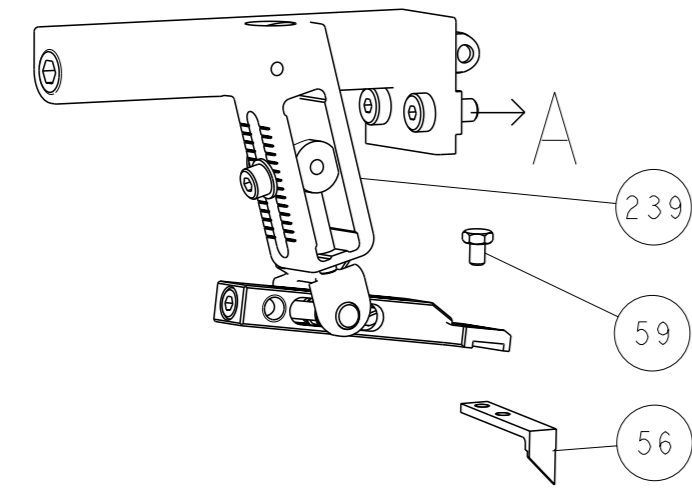

PNEUMATIC

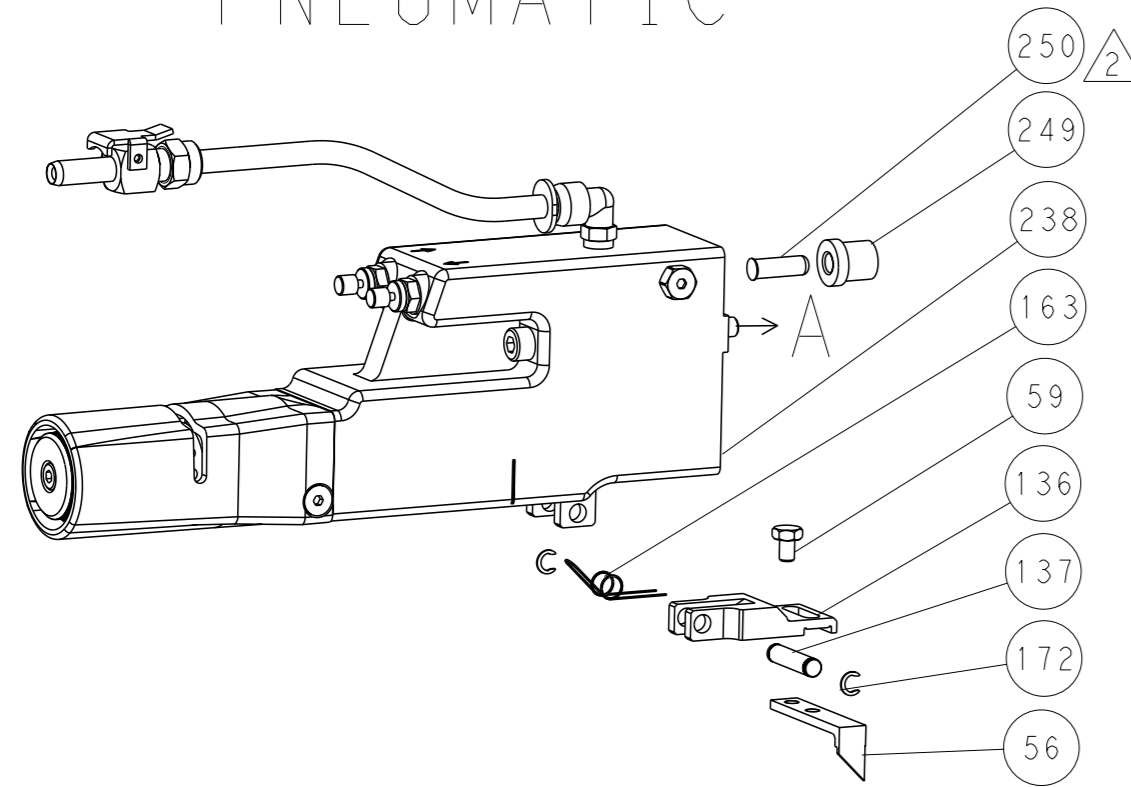

SERVO LATCH PLATE

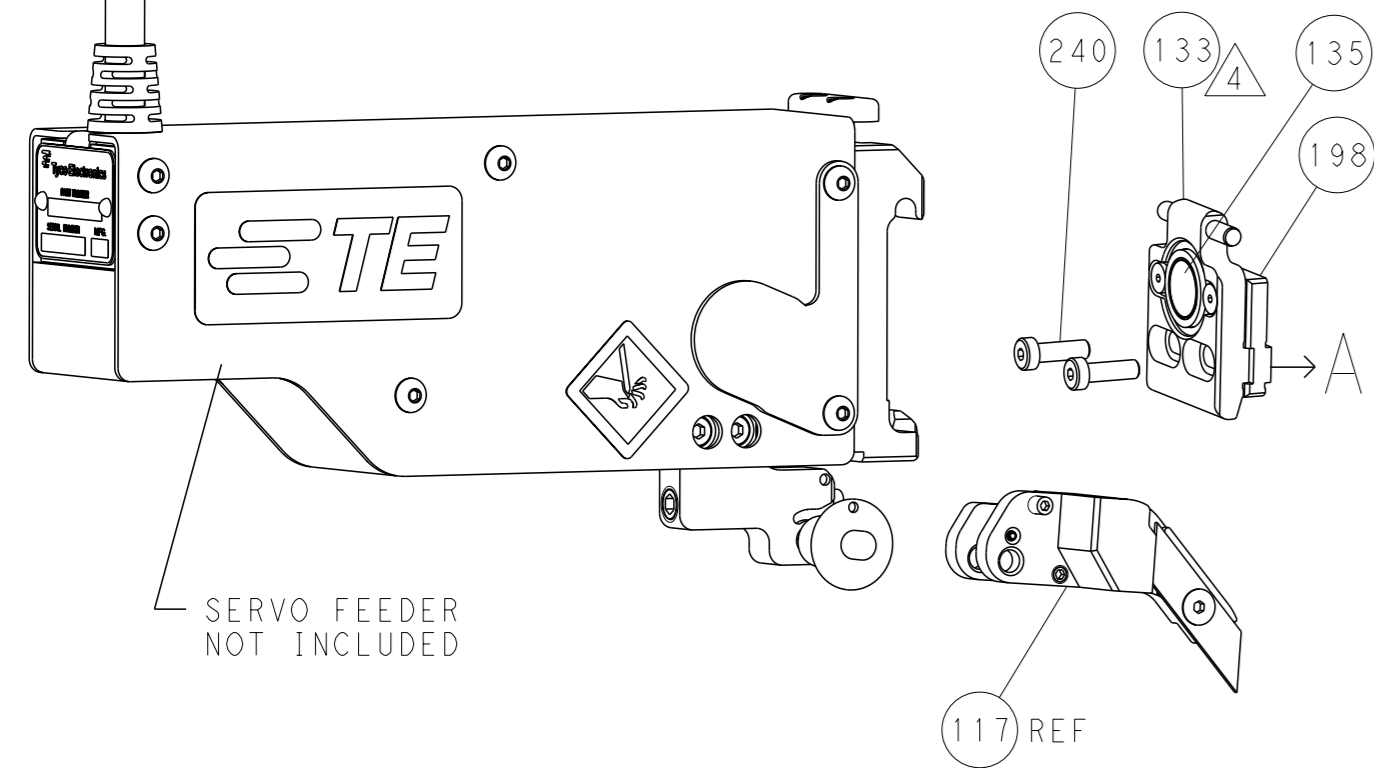

CAM POSITIONS

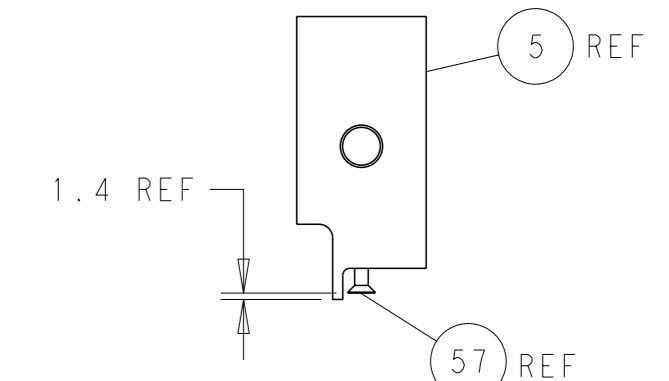
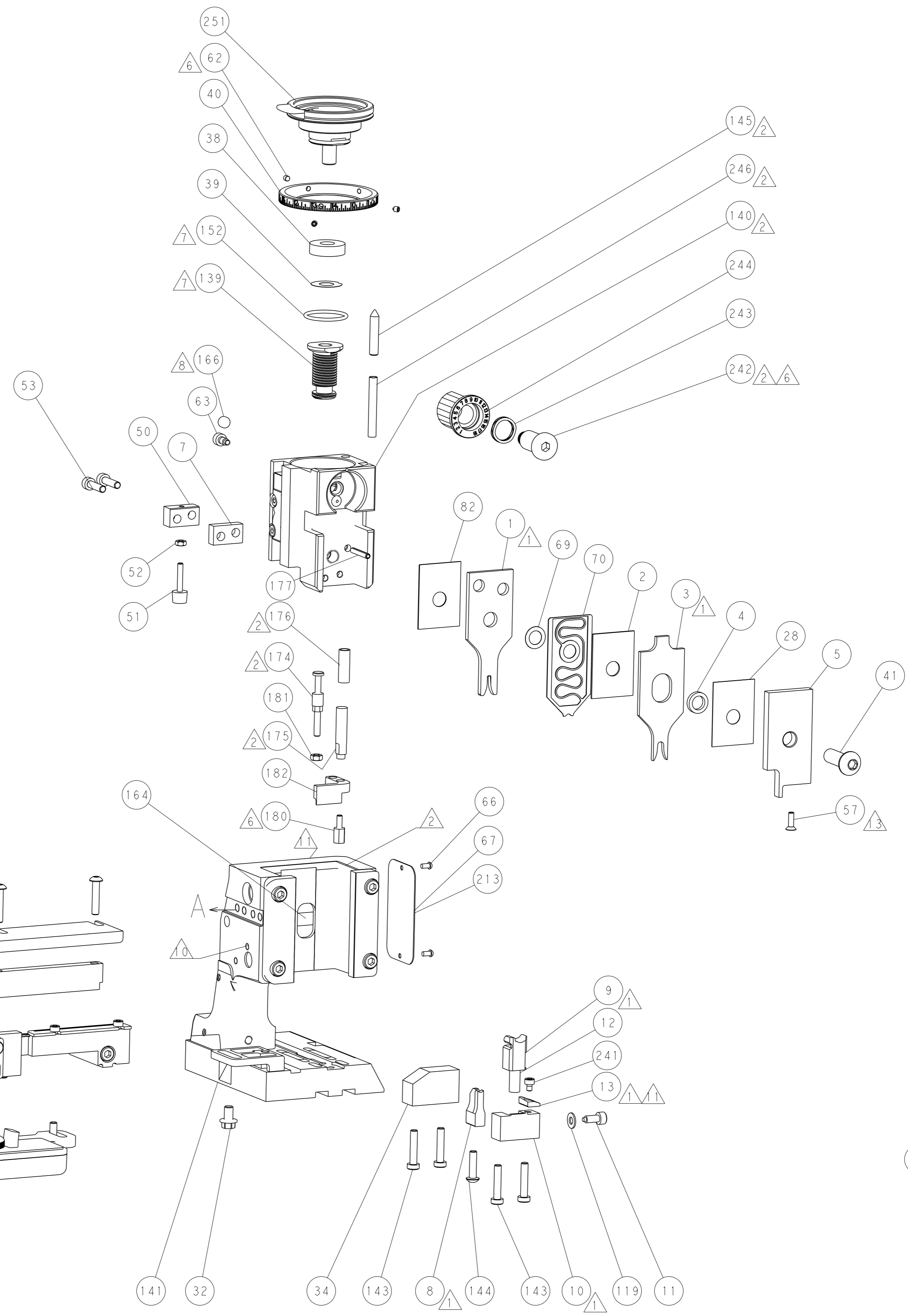
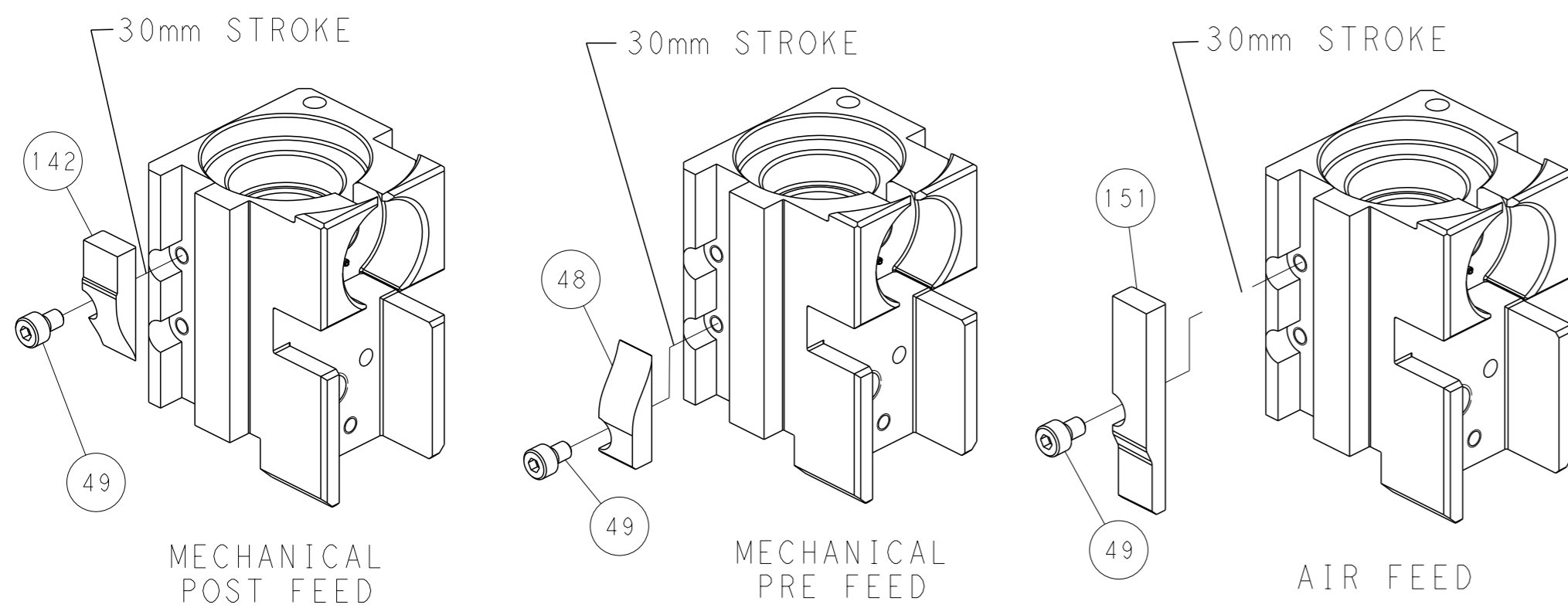

SHEAR DEPRESSOR DETAIL

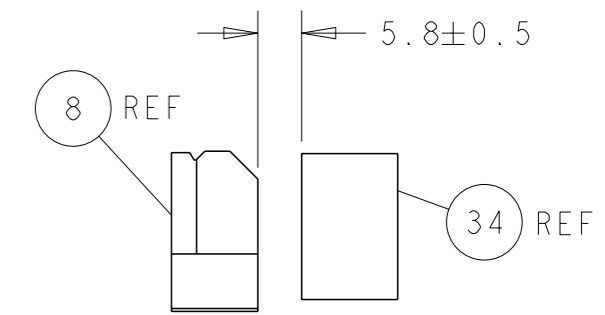

TERMINAL SUPPORT LOCATION

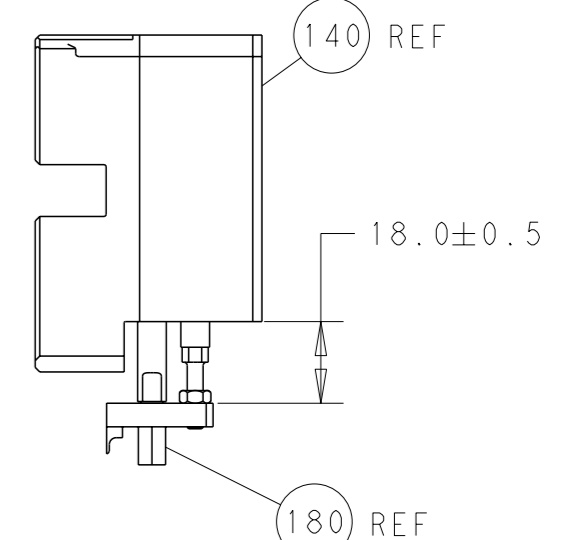

HOLDDOWN SET-UP

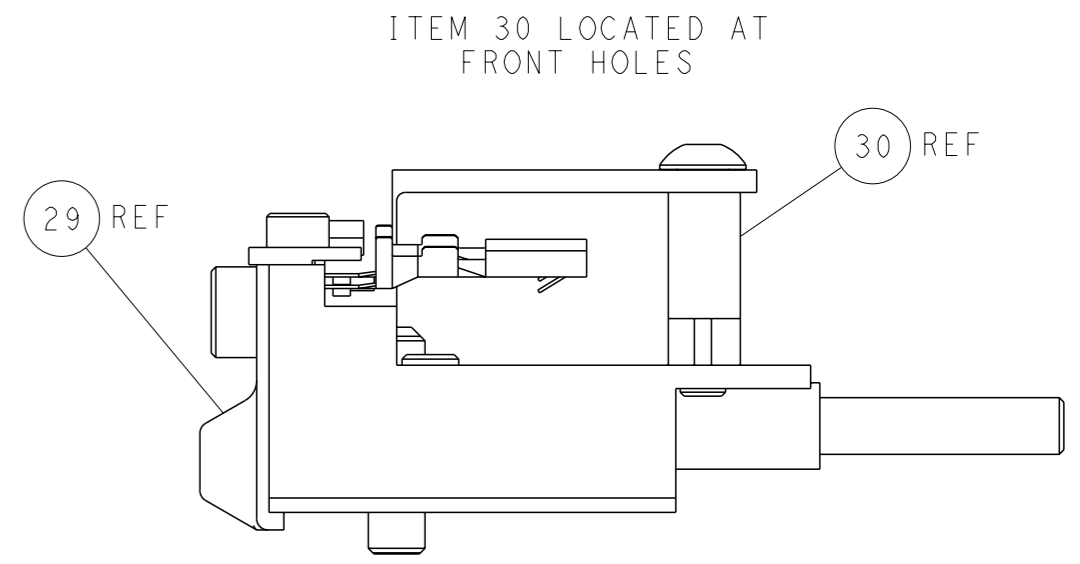

FEED TRACK POSITION GUIDE BY INSULATION BARREL

PACIFIC VERSION
 Shown on sheets 3 of 4 & 4 of 4
 (Atlantic version shown on sheets 1 of 4 & 2 of 4)

<small>THIS DRAWING IS A CONTROLLED DOCUMENT FOR TYCO ELECTRONICS CORPORATION. IT IS SUBJECT TO CHANGE AND THE CONTROLLER'S ENGINEERING DEPARTMENT SHOULD BE CONTACTED FOR THE LATEST REVISION.</small>		DWN: H. HUANG 26 JAN 2014 CHK: L. ZHANG 26 JAN 2014 APVD: J. GUO 26 JAN 2014	NAME: Ocean Side Feed Applicator SIZE: A1 SCALE: 1:2
DIMENSIONS: mm TOLERANCES UNLESS OTHERWISE SPECIFIED: 0 PLC ± 1 PLC ± 2 PLC ± 3 PLC ± 4 PLC ± ANGLES FINISH ±	TOLERANCES UNLESS OTHERWISE SPECIFIED: 0 PLC ± 1 PLC ± 2 PLC ± 3 PLC ± 4 PLC ± ANGLES FINISH ±	PRODUCT SPEC APPLICATION SPEC WEIGHT Customer Accessible Production Drawing	TE Connectivity Harrisburg, PA 17105-3608 CAGE CODE DRAWING NO: 00779 DRAWING NO: 2266201 SHEET 4 OF 4 REV B1