

LOC AD	DIST 25	REVISIONS				
P	LTR	DESCRIPTION	DATE	DWN	APVD	
	0	DRAWN	-	-	-	

1. WIRE BARREL WILL ACCEPT 8 AWG WIRE.
2. MATES WITH PART NUMBER 148430-1.
3. RECOMMENDED CRIMPING TOOL: DANIELS TOOL #M300-BT, POSITIONER PART NUMBER SP689, SETTING #7, STRIP LENGTH 8.13 [.320].

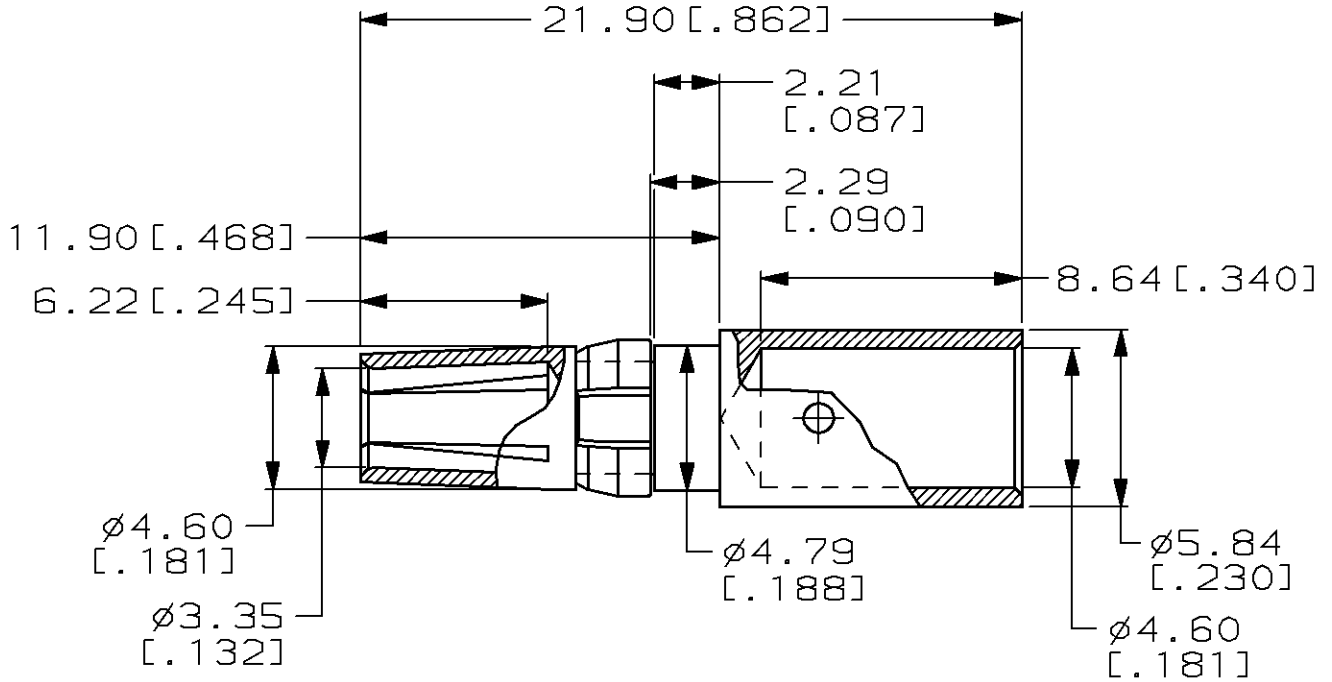

RELEASED FOR PUBLICATION

THIS DRAWING IS UNPUBLISHED.

ALL RIGHTS RESERVED. BY AMP INCORPORATED. COPYRIGHT 19

0.00076 [.000030] GOLD	CONTACT; BERYLLIUM COPPER RETAINING RING; BERYLLIUM COPPER	148432-1
FINISH	MATERIAL	PART NUMBER

DIMENSIONS: mm	DWN L. BRINER 9/14/98	MATERIAL -	FINISH -		
	CHK R. PATTERSON 9/14/98	AMP Incorporated Harrisburg, PA 17105-3608			
TOLERANCES UNLESS OTHERWISE SPECIFIED:	APVD R. PATTERSON 9/14/98			NAME POWER CONTACT, FEMALE CRIMP, AWG 8, (40 AMP)	
0 PLC ±-	PRODUCT SPEC	SIZE	CAGE CODE	DRAWING NO	RESTRICTED TO
1 PLC ±-	-	A4	00779	C- 148432	-
2 PLC ±0.13 [.005]	APPLICATION SPEC	CUSTOMER DRAWING		SCALE 4:1	SHEET 1 OF 1
3 PLC ±-	-	WEIGHT -		REV 0	
4 PLC ±-	-	AMP 1469-35 REV 11JUN97			
ANGLES ±-	-				

