

REVISIONS					
REV	ECO	DESCRIPTION	DATE	BY	APPR
A1	-	FIRST RELEASE	Jul.31,18	White	Tommy
A2	-	UPDATED DRAWING	Dec.11,18	White	Tommy

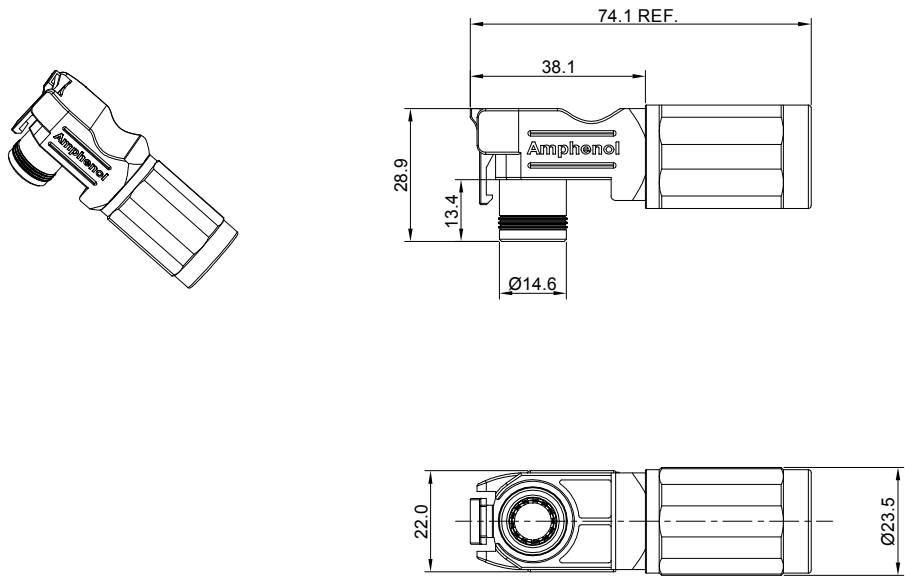

NOTES: UNLESS OTHERWISE SPECIFIED

- MATERIAL:
 - HOUSING: THERMOPLASTIC UL94 V0
 - SEAL: SILICONE RUBBER
 - NUT: THERMOPLASTIC UL94 V0
 - CONTACT: COPPER ALLOY,SILVER PLATED
- SPECIFICATIONS:
 - CURRENT RATING: 50 mm² @180 AMPS
35 mm² @130 AMPS
 - OPERATING VOLTAGE: 1000V AC/DC
 - OPERATING TEMPERATURE: -55°C TO +125°C
 - CONTACT RESISTANCE: 0.3 mΩ
 - DEGREE OF PROTECTION: IP67 (MATED CONDITION)
 - MATING CYCLE DURABILITY: 50 CYCLES
 - RoHS COMPLIANT
- ALL DIMENSIONS ARE FOR REFERENCE USE ONLY.





ITEM	P/N	CABLE OD RANGE	WIRE RANGE	NOTE
1	ATHP061RS08NN-50	14.2~15.2 mm	50 mm ²	BLACK
2	ATHP061RS08NN-35	10.7~11.7 mm	35 mm ²	BLACK
3	ATHP061RS08NN-50-ORG	14.2~15.2 mm	50 mm ²	ORANGE
4	ATHP061RS08NN-35-ORG	10.7~11.7 mm	35 mm ²	ORANGE

QUANTITY	PART NUMBER	DESCRIPTION	ITEM
MATERIALS LIST			
UNLESS OTHERWISE SPECIFIED 1) All dimensions are in metric(mm). 2) Tolerances are as follows: 1 PL DEC ±0.30 Fractions ±1/64 2 PL DEC ±0.15 3 PL DEC ±0.08 3) Note reference =		SIGNATURES DATE DRAWN: White Dec.11,18 CHECKED: Tod Dec.11,18 APPROVAL: Tommy Dec.11,18	
MATERIAL SPECIFICATIONS: PROCESS SPECIFICATIONS: NEXT ASSY:		<div style="text-align: center;"> Sine Systems - www.amphenol-sine.com 44724 Morley Drive Clinton Township, MI 48036 ATHP,8MM, RIGHTANGLE PLUG </div>	
THIS DRAWING IS SUPPLIED FOR INFORMATION ONLY. DESIGN FEATURES, SPECIFICATIONS AND PERFORMANCE DATA SHOWN HEREON ARE THE PROPERTY OF THE AMPHENOL CORPORATION. NO RIGHTS OF REPRODUCTION ARE IMPLIED. ALL DIMENSIONS ARE SUBJECT TO NORMAL MANUFACTURING VARIATIONS.		SCALE: NONE	
SIZE B C-		REVISION A2	
DWG NO: ATHP061RS08NN-xx-x		SHEET 1 OF 1	

TITLE: ATHP,8MM,RIGHTANGLE PLUG DWG NO.: ATHP061RS08NN-xx-x REV: A2 SH: 1 OF: 1

MagnaMate™ ATHP QL - Contact Options

Power Contacts - Machined Contacts, Sockets & Pins					
Part Number	Description	Size	AWG	Type	Amps
SC000500-835	Male Contact - Pin, Copper Alloy, Nickel-Plated	8mm	35mm ²	Machined	130A
SC000500-850	Male Contact - Pin, Copper Alloy, Nickel-Plated	8mm	50mm ²	Machined	180A
SC000501-835	Female Contact - Socket, Copper Alloy, Nickel-Plated	8mm	35mm ²	Machined	130A
SC000501-850	Female Contact - Socket, Copper Alloy, Nickel-Plated	8mm	50mm ²	Machined	180A
SC000511	Male Contact - Flat Hole Tail, Copper Alloy, Nickel	8mm		Machined	180A

Tooling - Machined Contacts		
Part	Part Number	Description
	WA23	Heavy Duty Pneumatic Crimp Tool -Uses Universal Positioner Part No. WA23-101DA and Crimp Locator MFX-3961
	WA23-8	Die Assembly, 50mm -for WA23 Heavy Duty Pneumatic Crimp Tool
	WA23-184DA	Die Assembly, 35mm -for WA23 Heavy Duty Pneumatic Crimp Tool
	WA23-10	Contact Locator, Size 50mm
	96-978-22	Crimper and Dies -for Size 10mm ² -185mm ² Wires

Amphenol Sine Systems
 44724 Morley Drive
 Clinton Township, MI 48036 USA
www.amphenol-sine.com
 04/2022