

28F0121-0SR

STEWART PART NUMBERING SYSTEM					
MATERIAL TYPE	PRODUCT CODE	PART SIZE CODE	SELECTED DIMENSION CODE	ADDITIONAL DESCRIPTION	PACKAGING CODE
28	F	0121	- 0	S	R

Ambient Operating Temperature Range :-55°C to +125°C

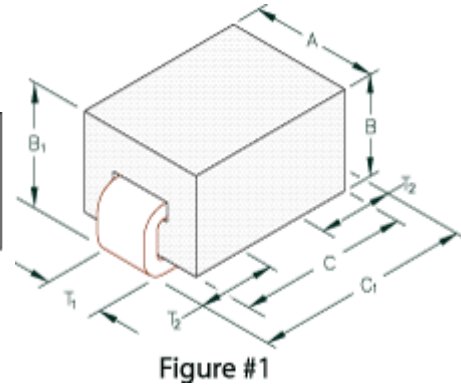

STEWART	
PRODUCT SERIES CODE	Ambient Oper
DM	

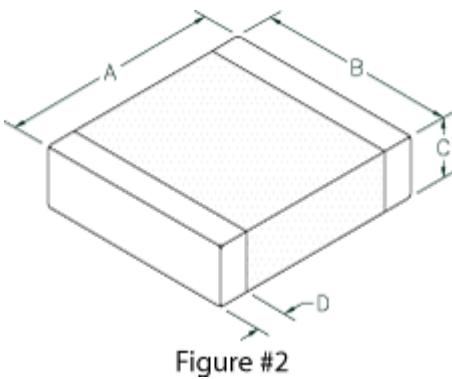

 Contact Steward for Lead Free Parts!

Drawing Figure

Figure Number
1

Electrical Characteristics

NET Z (Ω) @ 25 MHz	NET Z (Ω) @ 100 MHz	NET Z (Ω) @ 300 MHz	DCR Max (Ω)	Rated Current mA (continuous)
30	48	52	0.00075	10000

Physical Dimensions

A mm	B mm	B1 mm	C mm	C1 mm	D mm	A in	B in	B1 in	C in	C1 in	D in
3.05	2.54	3.05	4.06	5.08	-	0.120	0.100	0.120	0.160	0.200	-

Wire Dimensions

T1 mm	T2 mm	T1 in	T2 in
1.27	1.52	0.050	0.060

