



AK4118A

High Feature 192kHz 24bit Digital Audio I/F Transceiver

GENERAL DESCRIPTION

The AK4118A is a digital audio transceiver supporting 192kHz, 24bits. The channel status decoder supports both consumer and professional modes. The AK4118A can automatically detect a Non-PCM bit stream. When combined with the multi channel codec (AK4626A or AK4628A), the two chips provide a system solution for AC-3 applications. The dedicated pins or a serial μ P I/F can control the mode setting. The small package, 48pin LQFP saves the system space.

*AC-3 is a trademark of Dolby Laboratories.

FEATURES

- AES3, IEC60958, S/PDIF, EIAJ CP1201 Compatible
- Low jitter Analog PLL
- PLL Lock Range: 8kHz ~ 192kHz
- Clock Source: PLL or X'tal
- 8-channel Receiver input
- 2-channel Transmission output (Through output or DIT)
- Auxiliary digital input
- De-emphasis for 32kHz, 44.1kHz, 48kHz and 96kHz
- Detection Functions
 - Non-PCM Bit Stream Detection
 - DTS-CD Bit Stream Detection
 - Sampling Frequency Detection
(32kHz, 44.1kHz, 48kHz, 88.2kHz, 96kHz, 176.4kHz, 192kHz)
 - Unlock & Parity Error Detection
 - Validity Flag Detection
 - DAT Start ID Detection
- Up to 24bit Audio Data Format
- Audio I/F: Master or Slave Mode
- 42-bit Channel Status Buffer
- Burst Preamble bit Pc and Pd Buffer for Non-PCM bit stream
- Q-subcode Buffer for CD bit stream
- Serial μ P I/F (I²C, SPI)
- Two Master Clock Outputs: 64fs/128fs/256fs/512fs
- Operating Voltage: 2.7 to 3.6V with 5V tolerance
- 8GPIO Port
- RX Data Input Detection
- Small Package: 48pin LQFP
- Ta: -10 to 70°C

■ Block Diagram

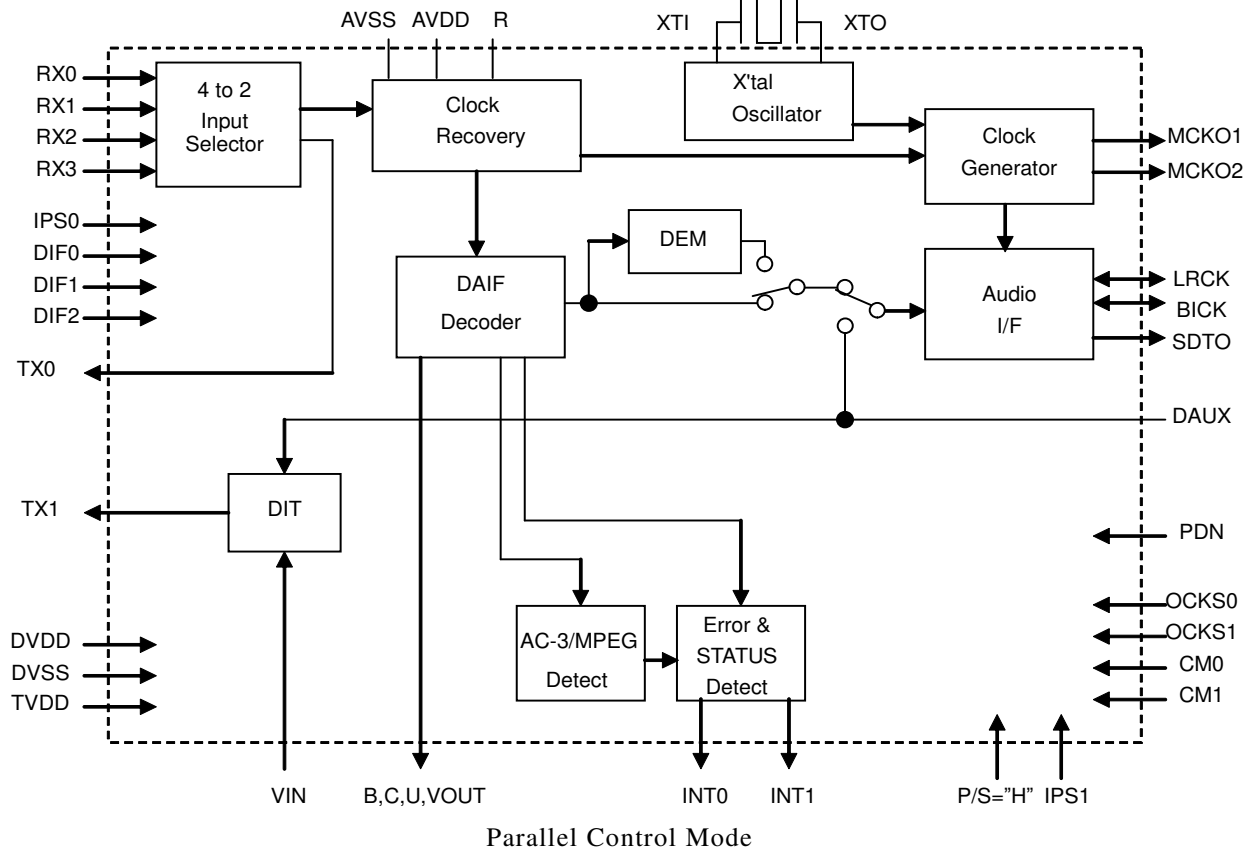
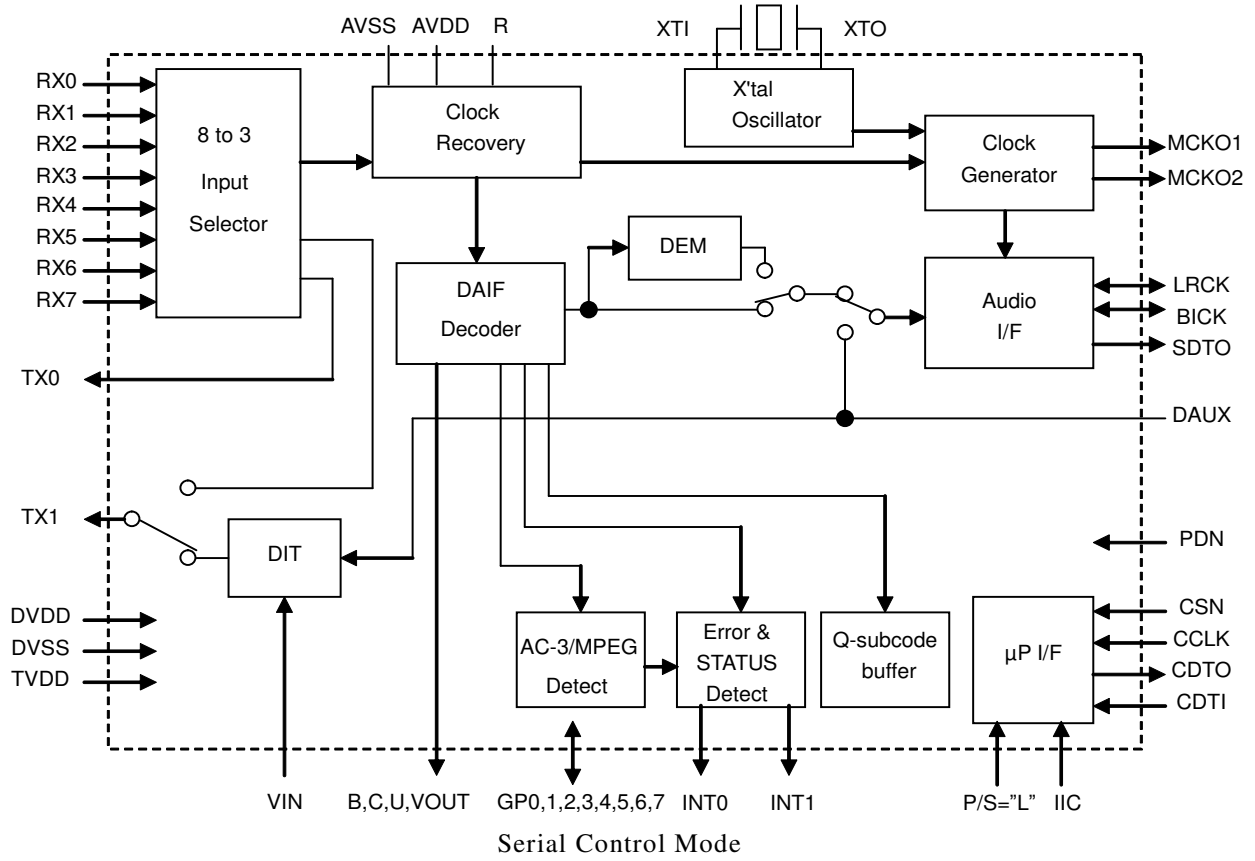

■ Ordering Guide

AK4118AEQ -10 ~ +70 °C 48pin LQFP (0.5mm pitch)
 AKD4118A Evaluation Board for AK4118A

■ Pin Layout

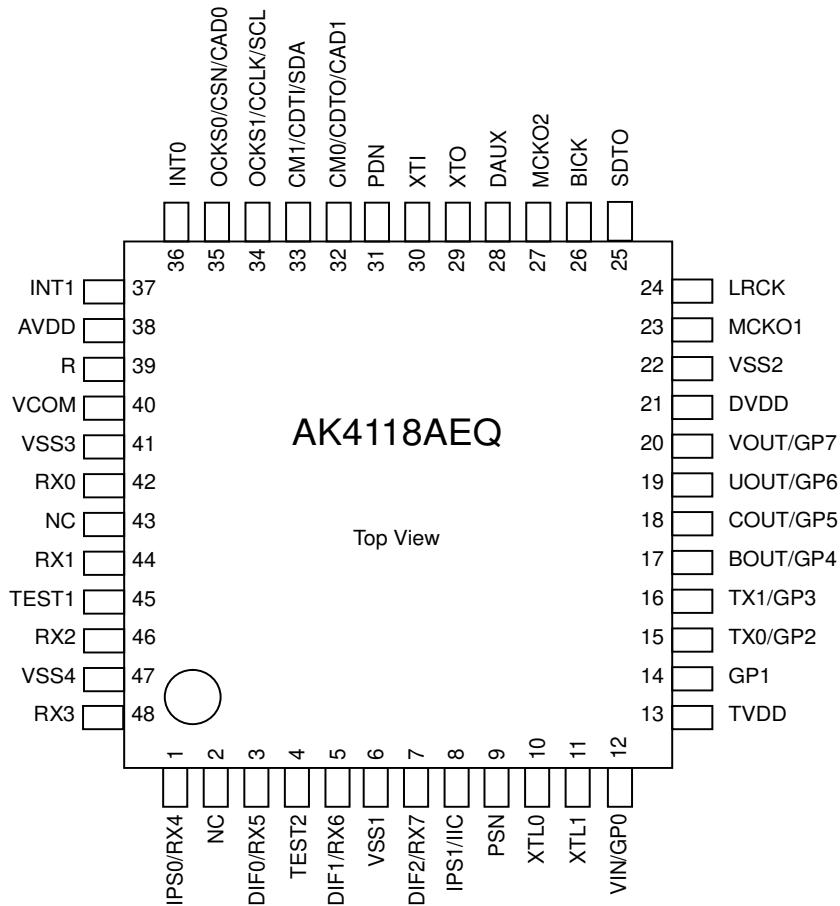

■ Compatibility with AK4118

1. Function and Characteristics

Function	AK4118A	AK4118
Master Clock	The MCKO2 pin outputs “L” when CM1-0 bit = “00” or “10” and UNLOCK bit = “0”.	The MCKO1 and MCKO2 pins output “256fs, 128fs, 64fs” clock according to OCKS1-0 bits setting, regardless of the clock source.
S/PDIF Receiver	Time deviation Jitter typ; 100ps RMS Cycle-to-Cycle Jitter typ; 50ps RMS	No descriptions about Jitter.

2. Register

Addr	Bit	AK4118A	AK4118
28H	D6	1	0

PIN/FUNCTION

No.	Pin Name	I/O	Function
1	IPS0	I	Input Channel Select 0 Pin in Parallel Mode
	RX4	I	Receiver Channel 4 Pin in Serial Mode (Internal biased pin)
2	NC	I	No Connect No internal bonding. This pin should be connected to VSS3.
3	DIF0	I	Audio Data Interface Format 0 Pin in Parallel Mode
	RX5	I	Receiver Channel 5 Pin in Serial Mode (Internal biased pin)
4	TEST2	I	TEST 2 pin This pin should be connect to VSS3.
5	DIF1	I	Audio Data Interface Format 1 Pin in Parallel Mode
	RX6	I	Receiver Channel 6 Pin in Serial Mode (Internal biased pin)
6	VSS1	I	Ground Pin
7	DIF2	I	Audio Data Interface Format 2 Pin in Parallel Mode
	RX7	I	Receiver Channel 7 Pin in Serial Mode (Internal biased pin)
8	IPS1	I	Input Channel Select 1 Pin in Parallel Mode
	IIC	I	IIC Select Pin in Serial Mode. “L”: 4-wire Serial, “H”: IIC
9	PSN	I	Parallel/Serial Select Pin “L”: Serial Mode, “H”: Parallel Mode
10	XTL0	I	X'tal Frequency Select 0 Pin
11	XTL1	I	X'tal Frequency Select 1 Pin
12	VIN	I	V-bit Input Pin for Transmitter Output
	GP0	I/O	GPIO0 pin in Serial Mode
13	TVDD	I	Input Buffer Power Supply Pin, DVDD ~5.5V
14	GP1	I/O	GPIO1 pin1 in Serial Mode
15	TX0	O	Transmit Channel (Through Data) Output 0 Pin
	GP2	I/O	GPIO2 pin in Serial Mode
16	TX1	O	When TX bit = “0”, Transmit Channel (Through Data) Output 1 Pin. When TX bit = “1”, Transmit Channel (DAUX Data) Output Pin (Default). (TX bit= “1”: Default)
	GP3	I/O	GPIO3 pin in Serial Mode
17	BOUT	O	Block-Start Output Pin for Receiver Input “H” during first 40 flames.
	GP4	I/O	GPIO4 pin in Serial Mode
18	COUT	O	C-bit Output Pin for Receiver Input
	GP5	I/O	GPIO5 pin in Serial Mode
19	UOUT	O	U-bit Output Pin for Receiver Input
	GP6	I/O	GPIO6 pin in Serial Mode
20	VOUT	O	V-bit Output Pin for Receiver Input
	GP7	I/O	GPIO7 pin in Serial Mode
21	DVDD	I	Digital Power Supply Pin, 2.7V ~ 3.6V
22	VSS2	I	Ground Pin
23	MCKO1	O	Master Clock Output 1 Pin
24	LRCK	I/O	Channel Clock Pin

PIN/FUNCTION (Continued)

No.	Pin Name	I/O	Function
25	SDTO	O	Audio Serial Data Output Pin
26	BICK	I/O	Audio Serial Data Clock Pin
27	MCKO2	O	Master Clock Output 2 Pin
28	DAUX	I	Auxiliary Audio Data Input Pin
29	XTO	O	X'tal Output Pin
30	XTI	I	X'tal Input Pin
31	PDN	I	Power-Down Mode Pin When "L", the AK4118A is powered-down, and all output pins go to "L" and registers are initialized.
32	CM0	I	Master Clock Operation Mode 1 Pin in Parallel Mode
	CDTO	O	Control Data Input Pin in Serial Mode, IIC= "L".
	CAD1	I	Control Data Pin in Serial Mode, IIC= "H".
33	CM1	I	Master Clock Operation Mode 1 Pin in Parallel Mode
	CDTI	I	Control Data Input Pin in Serial Mode, IIC= "L".
	SDA	I/O	Control Data Pin in Serial Mode, IIC= "H".
34	OCKS1	I	Output Clock Select 1 Pin in Parallel Mode
	CCLK	I	Control Data Clock Pin in Serial Mode, IIC= "L"
	SCL	I	Control Data Clock Pin in Serial Mode, IIC= "H"
35	OCKS0	I	Output Clock Select 0 Pin in Parallel Mode
	CSN	I	Chip Select Pin in Serial Mode, IIC="L".
	CAD0	I	Chip Address 0 Pin in Serial Mode, IIC= "H".
36	INT0	O	Interrupt 0 Pin
37	INT1	O	Interrupt 1 Pin
38	AVDD	I	Analog Power Supply Pin, 2.7V ~ 3.6V
39	R	-	External Resistor Pin 10kΩ +/-1% resistor should be connected to VSS3 externally.
40	VCOM	-	Common Voltage Output Pin 0.47μF capacitor should be connected to VSS3 externally.
41	VSS3	I	Ground Pin
42	RX0	I	Receiver Channel 0 Pin (Internal biased pin) This channel is default in serial mode.
43	NC	I	No Connect No internal bonding. This pin should be connected to VSS3.
44	RX1	I	Receiver Channel 1 Pin (Internal biased pin)
45	TEST1	I	TEST 1 pin. This pin should be connected to VSS3.
46	RX2	I	Receiver Channel 2 Pin (Internal biased pin)
47	VSS4	I	Ground Pin
48	RX3	I	Receiver Channel 3 Pin (Internal biased pin)

Note 1. All input pins except internal biased pins (RX0-7 pins) should not be left floating.

ABSOLUTE MAXIMUM RATINGS

(VSS1-4=0V; [Note 2](#), [Note 3](#))

Parameter		Symbol	min	max	Units
Power Supplies:	Analog	AVDD	-0.3	4.6	V
	Digital	DVDD	-0.3	4.6	V
	Input Buffer	TVDD	-0.3	6.0	V
Input Current (Any pins except supplies)		IIN	-	±10	mA
Input Voltage (Except XTI pin)		VIN	-0.3	TVDD+0.3	V
Input Voltage (XTI pin)		VINX	-0.3	DVDD+0.3	V
Ambient Temperature (Power applied)		Ta	-10	70	°C
Storage Temperature		Tstg	-65	150	°C

Note 2. All voltages with respect to ground.

Note 3. VSS1-4 must be connected to the same ground.

WARNING: Operation at or beyond these limits may result in permanent damage to the device.

Normal operation is not guaranteed at these extremes.

RECOMMENDED OPERATING CONDITIONS

(VSS1-4=0V; [Note 2](#))

Parameter		Symbol	min	typ	max	Units
Power Supplies:	Analog	AVDD	2.7	3.3	3.6	V
	Digital	DVDD	2.7	3.3	AVDD	V
	Input Buffer	TVDD	DVDD	5.0	5.5	V

Note 2. All voltages with respect to ground. There is no level shifter.

S/PDIF RECEIVER CHARACTERISTICS
--

(Ta=25°C; AVDD=DVDD=2.7~3.6V; TVDD=2.7~5.5V)

Parameter	Symbol	min	typ	max	Units
Input Resistance	Zin		10		kΩ
Input Voltage	VTH	200			mVpp
Input Hysteresis	VHY	-	50		mV
Input Sample Frequency	fs	8	-	192	kHz
Time deviation Jitter (Note 4)		-	100	-	ps RMS
Cycle - to - Cycle Jitter (Note 4)		-	50	-	ps RMS

Note 4. AVDD=DVDD=3.3V, TVDD=5.0V, fs=48kHz

DC CHARACTERISTICS

(Ta=25°C; AVDD=DVDD=2.7~3.6V; TVDD=2.7~5.5V; unless otherwise specified)

Parameter	Symbol	min	typ	max	Units
Power Supply Current					
Normal operation: PDN = "H" (Note 5)			32	53	mA
Power down: PDN = "L" (Note 6)			10	100	μA
High-Level Input Voltage	VIH	70%DVDD	-	TVDD	V
Low-Level Input Voltage	VIL	VSS2-0.3	-	30%DVDD	V
High-Level Output Voltage (Iout=-400μA)	VOH	DVDD-0.4	-	-	V
Low-Level Output Voltage					
(Except SDA pin: Iout=400μA)	VOL	-	-	0.4	V
(SDA pin: Iout= 3mA)	VOL	-	-	0.4	V
Input Leakage Current	Iin	-	-	± 10	μA

Note 5. AVDD=DVDD=3.3V, TVDD=5.0V, CL=20pF, fs=192kHz, X'tal=24.576MHz, Clock Operation Mode 2,

OCSK1=1, OCSK0=1. AVDD=7mA (typ), DVDD=25mA (typ), TVDD=10μA (typ).

DVDD=36mA (typ) when the circuit of [Figure 23](#) is attached to both TX0 and TX1 pins.

Note 6. RX inputs are open and all digital input pins are held DVDD or VSS2.

SWITCHING CHARACTERISTICS

(Ta=25°C; DVDD=AVDD2.7~3.6V, TVDD=2.7~5.5V; C_L=20pF)

Parameter		Symbol	min	typ	max	Units
Master Clock Timing						
Crystal Resonator	Frequency	fXTAL	11.2896		24.576	MHz
External Clock	Frequency (Note 7)	fECLK	8.192		24.576	MHz
	Duty	dECLK	40	50	60	%
MCKO1 Output	Frequency	fMCK1	4.096		24.576	MHz
	Duty	dMCK1	40	50	60	%
MCKO2 Output	Frequency	fMCK2	2.048		24.576	MHz
	Duty	dMCK2	40	50	60	%
PLL Clock Recover Frequency (RX0-7)		Fpll	8	-	192	kHz
LRCK Frequency		fs	8		192	kHz
Duty Cycle		dLCK	45		55	%
Audio Interface Timing						
Slave Mode						
BICK Period		tBCK	80			ns
BICK Pulse Width Low		tBCKL	30			ns
Pulse Width High		tBCKH	30			ns
LRCK Edge to BICK “↑”	(Note 8)	tLRB	20			ns
BICK “↑” to LRCK Edge	(Note 8)	tBLR	20			ns
LRCK to SDTO (MSB)		tLRM			30	ns
BICK “↓” to SDTO		tBSD			30	ns
DAUX Hold Time		tDXH	20			ns
DAUX Setup Time		tDXS	20			ns
Master Mode						
BICK Frequency		fBCK		64fs		Hz
BICK Duty		dBCK		50		%
BICK “↓” to LRCK		tMBLR	-20		20	ns
BICK “↓” to SDTO		tBSD	-15		15	ns
DAUX Hold Time		tDXH	20			ns
DAUX Setup Time		tDXS	20			ns
Control Interface Timing (4-wire serial mode)						
CCLK Period		tCCK	200			ns
CCLK Pulse Width Low		tCCKL	80			ns
Pulse Width High		tCCKH	80			ns
CDTI Setup Time		tCDS	50			ns
CDTI Hold Time		tCDH	50			ns
CSN “H” Time		tCSW	150			ns
CSN “↓” to CCLK “↑”		tCSS	50			ns
CCLK “↑” to CSN “↑”		tCSH	50			ns
CDTO Delay		tDCD			45	ns
CSN “↑” to CDTO Hi-Z		tCCZ			70	ns

Note 7. When fECLK=8.192MHz, sampling frequency detect function (page16) is disable.

Note 8. BICK rising edge must not occur at the same time as LRCK edge.

SWITCHING CHARACTERISTICS (Continued)
--

(Ta=25°C; DVDD=AVDD2.7~3.6V, TVDD=2.7~5.5V; C_L=20pF)

Parameter	Symbol	min	typ	max	Units
Control Interface Timing (I²C Bus mode):					
SCL Clock Frequency	fSCL	-		400	kHz
Bus Free Time Between Transmissions	tBUF	1.3		-	μs
Start Condition Hold Time (prior to first clock pulse)	tHD:STA	0.6		-	μs
Clock Low Time	tLOW	1.3		-	μs
Clock High Time	tHIGH	0.6		-	μs
Setup Time for Repeated Start Condition	tSU:STA	0.6		-	μs
SDA Hold Time from SCL Falling (Note 9)	tHD:DAT	0		-	μs
SDA Setup Time from SCL Rising	tSU:DAT	100		-	ns
Rise Time of Both SDA and SCL Lines	tR	-		300	ns
Fall Time of Both SDA and SCL Lines	tF	-		300	ns
Setup Time for Stop Condition	tSU:STO	0.6		-	μs
Capacitive load on bus	Cb	-		400	pF
Pulse Width of Spike Noise Suppressed by Input Filter	tSP	0		50	ns
Reset Timing					
PDN Pulse Width	tPW	150			ns

Note 9. Data must be held for sufficient time to bridge the 300 ns transition time of SCL.

Note 10. I²C-bus is a trademark of NXP B.V.

■ Timing Diagram

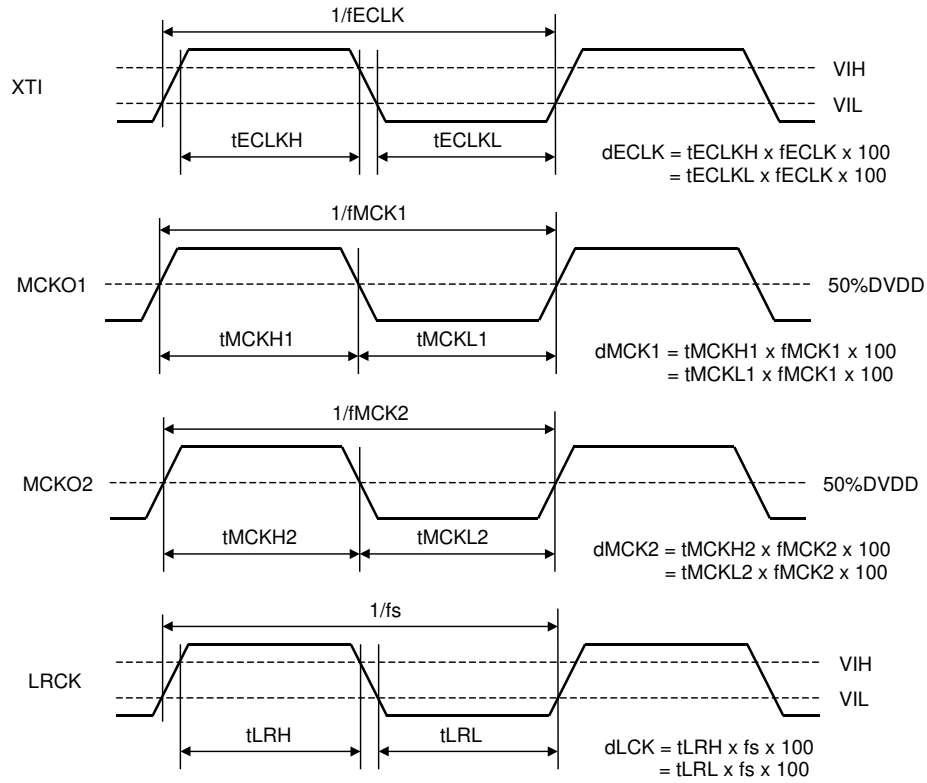

Figure 1. Clock Timing

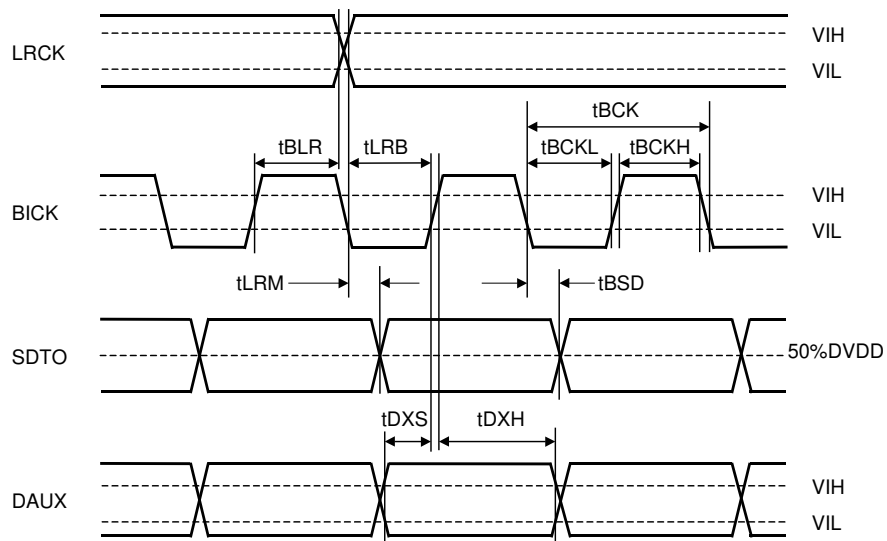

Figure 2. Serial Interface Timing (Slave Mode)

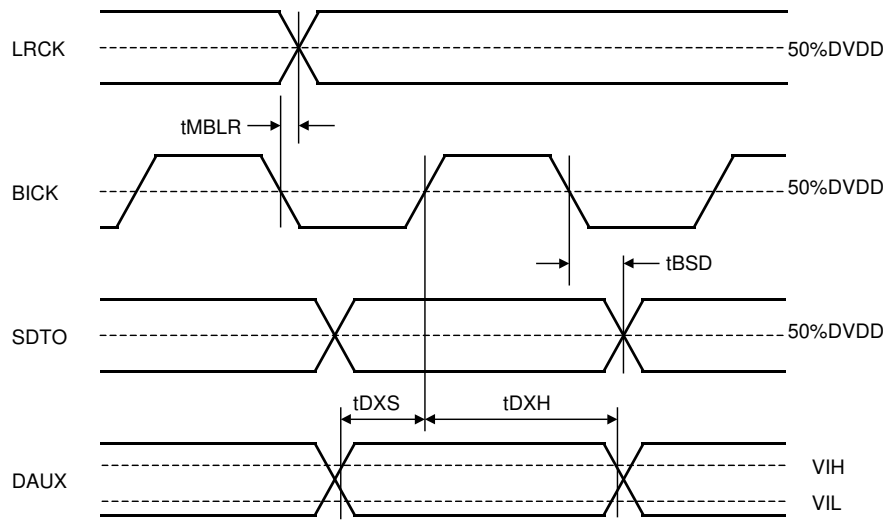

Figure 3. Serial Interface Timing (Master Mode)

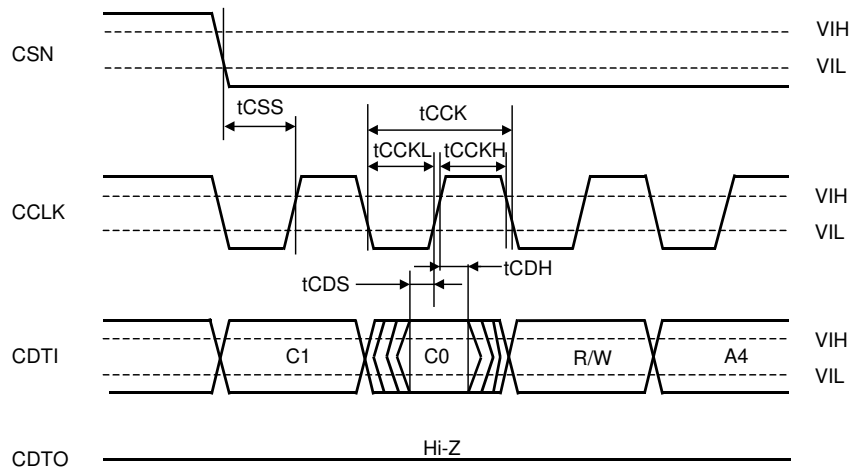

Figure 4. WRITE/READ Command Input Timing in 4-wire serial mode

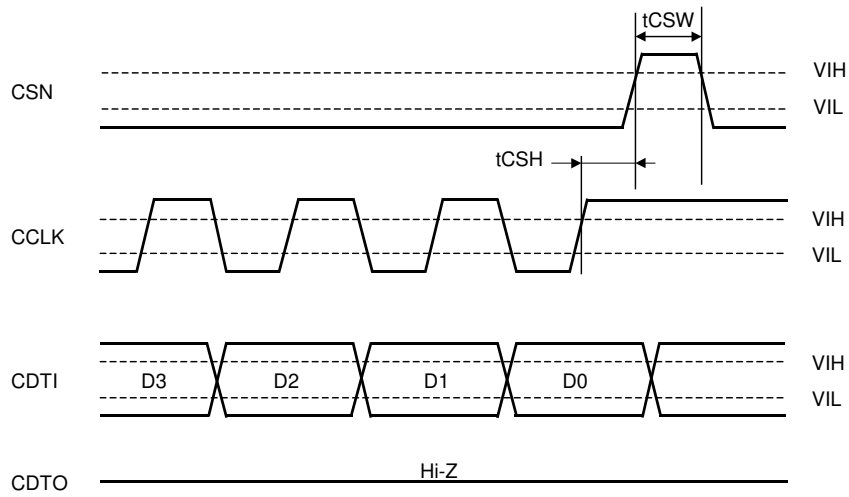

Figure 5. WRITE Data Input Timing in 4-wire serial mode

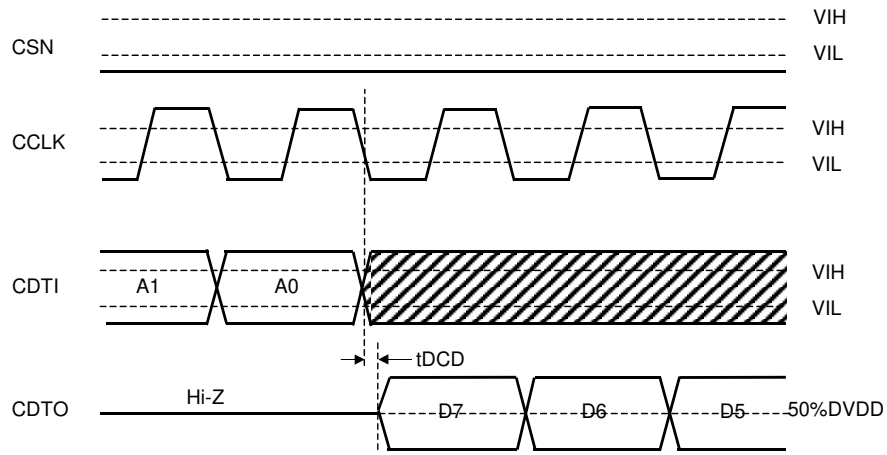

Figure 6. READ Data Output Timing 1 in 4-wire serial mode

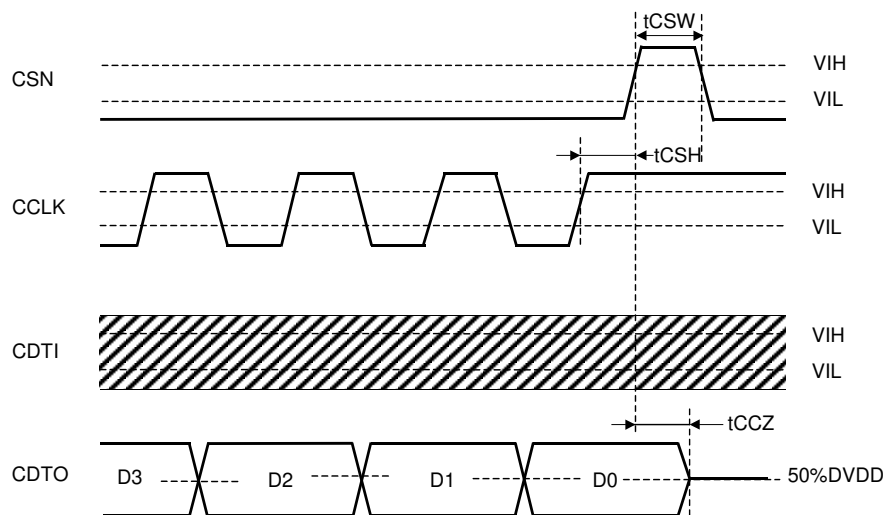

Figure 7. READ Data Input Timing 2 in 4-wire serial mode

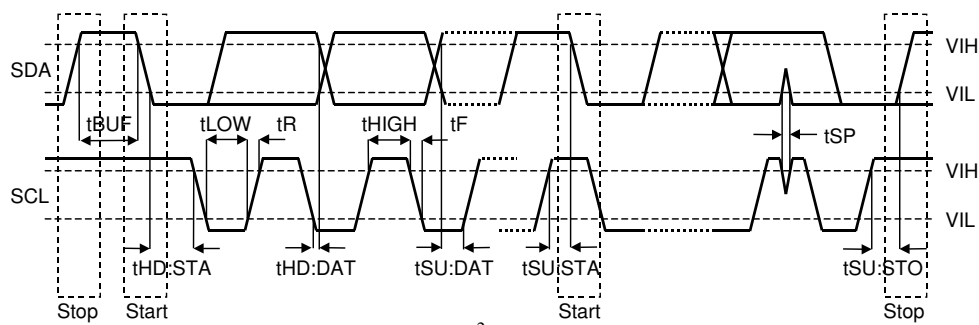

Figure 8. I²C Bus mode Timing

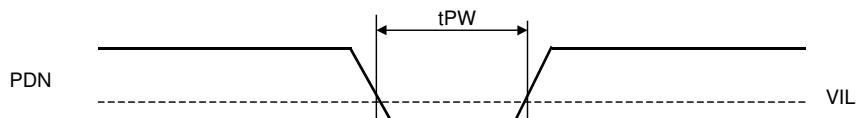

Figure 9. Power Down & Reset Timing

OPERATION OVERVIEW

■ Non-PCM (AC-3, MPEG, etc.) and DTS-CD Bitstream Detection

The AK4118A has a Non-PCM stream auto-detection function. When the 32bit mode Non-PCM preamble based on Dolby "AC-3 Data Stream in IEC60958 Interface" is detected, the AUTO bit goes "1". The 96bit sync code consists of 0x0000, 0x0000, 0x0000, 0x0000, 0xF872 and 0x4E1F. Detection of this pattern will set the AUTO bit "1". Once the AUTO is set "1", it will remain "1" until 4096 frames pass through the chip without additional sync pattern being detected. When those preambles are detected, the burst preambles Pc and Pd that follow those sync codes are stored to registers. The AK4118A also has the DTS-CD bitstream auto-detection function. When AK4118A detects DTS-CD bitstreams, DTSCD bit goes to "1". When the next sync code does not come within 4096 frames, DTSCD bit goes to "0" until when AK4118A detects the stream again. The AK4118A detects 14bit Sync Word and 16bit Sync Word of DTS-CD bitstream. In Serial control mode this detect function can be ON/OFF by DTS14 bit and DTS16 bit.

■ 192kHz Clock Recovery

The integrated low jitter PLL has a wide lock range from 8kHz to 192kHz and the lock time is dependent on the sampling frequency and FAST bit setting (Table 1). FAST bit is useful at lower sampling frequency and is fixed to "1" in parallel control mode. In serial control mode, the AK4118A has a sampling frequency detection function (8kHz, 11.025kHz, 16kHz, 22.05kHz, 24kHz, 32kHz, 44.1kHz, 48kHz, 64kHz, 88.2kHz, 96kHz, 176.4kHz, 192kHz) that uses either a clock comparison against the X'tal oscillator or the channel status information from the setting of XTL1-0 bits. In parallel control mode, the sampling frequency is detected by using the reference frequency, 24.576MHz. When the sampling frequency is more than 64kHz, the FS96 pin goes to "H". When the sampling frequency is less than 54kHz, the FS96 pin goes to "L". The PLL loses lock when the received sync interval is incorrect.

FAST bit	PLL Lock Time	
0	$\leq (15 \text{ ms} + 384/\text{fs})$	(default)
1	$\leq (15 \text{ ms} + 1/\text{fs})$	

Table 1. PLL Lock Time (fs: Sampling Frequency)

■ Master Clock

The AK4118A has two clock outputs, MCKO1 and MCKO2. The MCKO2 pin output mode is selected by XMCK bit.

1) XMCK bit = "0"

The AK4118A has two clock outputs, MCKO1 and MCKO2. These clocks are derived from either the recovered clock or from the X'tal oscillator. The frequencies of the master clock outputs (MCKO1 and MCKO2) are set by OCKS0 and OCKS1 as shown in Table 2. The 512fs clock will not output when 96kHz and 192kHz. The 256fs clock will not output when 192kHz. The MCKO2 pin outputs "L" when PLL is the clock source.

No.	OCKS1	OCKS0	MCKO1	MCKO2	X'tal	fs (max)	
0	0	0	256fs	"L"	256fs	96 kHz	(default)
1	0	1	256fs	"L"	256fs	96 kHz	
2	1	0	512fs	"L"	512fs	48 kHz	
3	1	1	128fs	"L"	128fs	192 kHz	

When CM1-0 bits = "00" or "10" and UNLOCK bit = "0"

Table 2. Master Clock Frequency Select (Stereo mode)

When X'tal signal is the clock source, the clock can be output from the MCKO1 and MCKO2 pins. (Table 3)

No.	OCKS1	OCKS0	MCKO1	MCKO2	X'tal	fs (max)	(default)
0	0	0	256fs	256fs	256fs	96 kHz	
1	0	1	256fs	128fs	256fs	96 kHz	
2	1	0	512fs	256fs	512fs	48 kHz	
3	1	1	128fs	64fs	128fs	192 kHz	

When CM1-0 bits = "01", "11" or "10" and UNLOCK bit= "1"

Table 3. Master Clock Frequency Select (Stereo mode)

2) XMCK bit = "1"

The MCKO2 pin outputs the input clock of the XTI pin regardless of OCKS1-0 bit settings. DIV bit can set the output frequency. The MCKO1 pin outputs the clock according to the CM1-0 and OCKS1-0 bit settings.

XMCK bit	DIV bit	MCKO2 Clock Source	MCKO2 Frequency
1	0	X'tal	x 1
1	1	X'tal	x 1/2

Table 4. MCKO2 pin Output Frequency Setting

■ Clock Operation Mode

The CM0/CM1 pins (or bits) select the clock source and the data source of SDTO. In Mode 2, the clock source is switched from PLL to X'tal when PLL goes unlock state. In Mode3, the clock source is fixed to X'tal, but PLL is also operating and the recovered data such as C bits can be monitored. For Mode2 and Mode3, it is recommended that the frequency of X'tal is different from the recovered frequency from PLL.

Mode	CM1	CM0	UNLOCK	PLL	X'tal	Clock source	MCKO1	MCKO2	SDTO	(default)
0	0	0	-	ON	ON(Note)	PLL	PLL	"L"	RX	
1	0	1	-	OFF	ON	X'tal	X'tal	X'tal	DAUX	
2	1	0	0	ON	ON	PLL	PLL	"L"	RX	
			1	ON	ON	X'tal	X'tal	X'tal	DAUX	
3	1	1	-	ON	ON	X'tal	X'tal	X'tal	DAUX	

ON: Oscillation (Power-up), OFF: STOP (Power-Down)

Note: When the X'tal is not used as clock comparison for fs detection (i.e. XTL1/0 pins= "H"), the X'tal is off.

When the clock source is PLL in Mode 0 and Mode 2, the MCKO2 pin is fixed to "L".

Table 5. Clock Operation Mode select

■ Clock Source

The clock for the XTI pin can be generated by the following methods:

1) X'tal

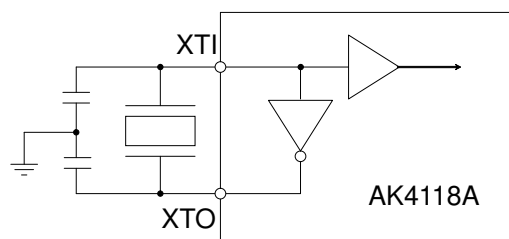

Figure 10. X'tal Mode

Note: External capacitance depends on the crystal oscillator (Max. 30pF)

2) External clock

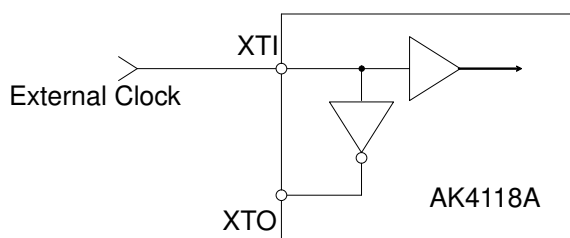

Figure 11. External clock mode

Note: Input clock must not exceed DVDD.

3) Fixed to the Clock Operation Mode 0

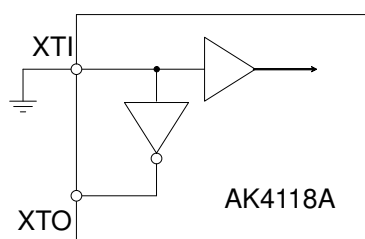

Figure 12. OFF Mode

■ Sampling Frequency and Pre-emphasis Detection

The AK4118A has two methods for detecting the sampling frequency as follows.

1. Clock comparison between recovered clock and X'tal oscillator
2. Sampling frequency information on channel status

Those could be selected by XTL1/0 pins. And the detected frequency is reported on FS3-0 and PEM bits.

XTL1	XTL0	X'tal Frequency
L	L	11.2896MHz
L	H	12.288MHz
H	L	24.576MHz
H	H	(Use channel status)

(default)

Table 6. Reference X'tal frequency

Register output				fs	XTL1-0 bit ≠ "11"	XTL1-0 bit = "11"		
						Consumer mode (Note 12)	Professional mode (Note 13)	
FS3	FS2	FS1	FS0			Byte3 Bit3,2,1,0	Byte0 Bit7,6	Byte4 Bit6,5,4,3
0	0	0	0	44.1kHz	44.1kHz ± 3%	0 0 0 0	0 1	0 0 0 0
0	0	0	1	Reserved	-	0 0 0 1	(Others)	
0	0	1	0	48kHz	48kHz ± 3%	0 0 1 0	1 0	0 0 0 0
0	0	1	1	32kHz	32kHz ± 3%	0 0 1 1	1 1	0 0 0 0
0	1	0	0	22.05kHz	22.05kHz ± 3%	0 1 0 0	0 0	1 0 0 1
0	1	0	1	11.025kHz	11.025kHz ± 3%	/	/	/
0	1	1	0	24kHz	24kHz ± 3%	0 1 1 0	0 0	0 0 0 1
0	1	1	1	16kHz	16kHz ± 3%	/	/	/
1	0	0	0	88.2kHz	88.2kHz ± 3%	1 0 0 0	0 0	1 0 1 0
1	0	0	1	8kHz	8kHz ± 3%	/	/	/
1	0	1	0	96kHz	96kHz ± 3%	1 0 1 0	0 0	0 0 1 0
1	0	1	1	64kHz	64kHz ± 3%	/	/	/
1	1	0	0	176.4kHz	176.4kHz ± 3%	1 1 0 0	0 0	1 0 1 1
1	1	1	0	192kHz	192kHz ± 3%	1 1 1 0	0 0	0 0 1 1

Note 11. At least ±3% frequency range is identified as the values in the Table 7. FS3-0 bits indicate nearer frequency for the intermediate frequency of two values. When the frequency is over the range of 32kHz to 192kHz, FS3-0 bits may indicate "0001".

Note 12. When consumer mode, Byte3 Bit3-0 are copied to FS3-0.

Note 13. In professional mode, FS3-0 bits are always "0001" except for the frequencies listed in the table.

Table 7. Sampling Frequency Information

The pre-emphasis information is detected and reported on PEM bit. This information is extracted from channel 1 at default. It can be switched to channel 2 by CS12 bit in control register.

PEM	Pre-emphasis	Byte 0, Bits 3-5
0	OFF	≠ 0X100
1	ON	0X100

Table 8. PEM in Consumer Mode

PEM	Pre-emphasis	Byte 0, Bits 2-4
0	OFF	≠ 110
1	ON	110

Table 9. PEM in Professional Mode

■ De-emphasis Filter Control

The AK4118A has a digital de-emphasis filter ($t_c=50/15\mu s$) which corresponds to four sampling frequencies (32kHz, 44.1kHz, 48kHz and 96kHz) by IIR filter. When DEAU bit="1", the de-emphasis filter is enabled automatically by sampling frequency and pre-emphasis information in the channel status. The AK4118A is in this mode as default. Therefore, in Parallel Mode, the AK4118A is always placed in this mode and the status bits in channel 1 control the de-emphasis filter. In Serial Mode, DEM0/1 and DFS bits can control the de-emphasis filter when DEAU bit is "0". The internal de-emphasis filter is bypassed and the recovered data is output without any change if either pre-emphasis or de-emphasis Mode is OFF.

PEM	FS3	FS2	FS1	FS0	Mode
1	0	0	0	0	44.1kHz
1	0	0	1	0	48kHz
1	0	0	1	1	32kHz
1	1	0	1	0	96kHz
1	(Others)				OFF
0	x	x	x	x	OFF

Table 10. De-emphasis Auto Control at DEAU = "1" (default)

PEM	DFS	DEM1	DEM0	Mode
1	0	0	0	44.1kHz
1	0	0	1	OFF
1	0	1	0	48kHz
1	0	1	1	32kHz
1	1	0	0	OFF
1	1	0	1	OFF
1	1	1	0	96kHz
1	1	1	1	OFF
0	x	x	x	OFF

(default)

Table 11. De-emphasis Manual Control at DEAU = "0"

■ System Reset and Power-Down

The AK4118A has a power-down mode for all circuits by the PDN pin, and can be partially powerd-down by PWN bit. The RSTN bit initializes the register and resets the internal timing. In Parallel Mode, only the control by the PDN pin is enabled. The AK4118A should be reset once by bringing the PDN pin = "L" upon power-up.

PDN Pin:

All analog and digital circuit are placed in the power-down and reset mode by bringing the PDN pin="L". All the registers are initialized, and clocks are stopped. Reading/Writing to the register are disabled.

RSTN Bit (Address 00H; D0):

All the registers except PWN and RSTN are initialized by bringing RSTN bit = "0". The internal timings are also initialized. Writing to the register is not available except PWN and RSTN bits. Reading to the register is disabled.

PWN Bit (Address 00H; D1):

The clock recovery part is initialized by bringing PWN bit = "0". In this case, clocks are stopped. The registers are not initialized and the mode settings are kept. Writing and Reading to the registers are enabled.

■ Biphase Input and Through Output

Eight receiver inputs (RX0-7) are available in Serial Control Mode. Each input includes amplifier corresponding to unbalance mode and can accept the signal of 200mV or more. IPS2-0 selects the receiver channel. When BCUV bit = “1”, the Block start signal, C bit and U bit can output from each pins. RXDE7-0 bits indicate the input signal status at the RX pin. When the signal is input to the RX pin, RXDE bit = “1”.

IPS2	IPS1	IPS0	INPUT Data
0	0	0	RX0 (default)
0	0	1	RX1
0	1	0	RX2
0	1	1	RX3
1	0	0	RX4
1	0	1	RX5
1	1	0	RX6
1	1	1	RX7

Table 12. Recovery Data Select

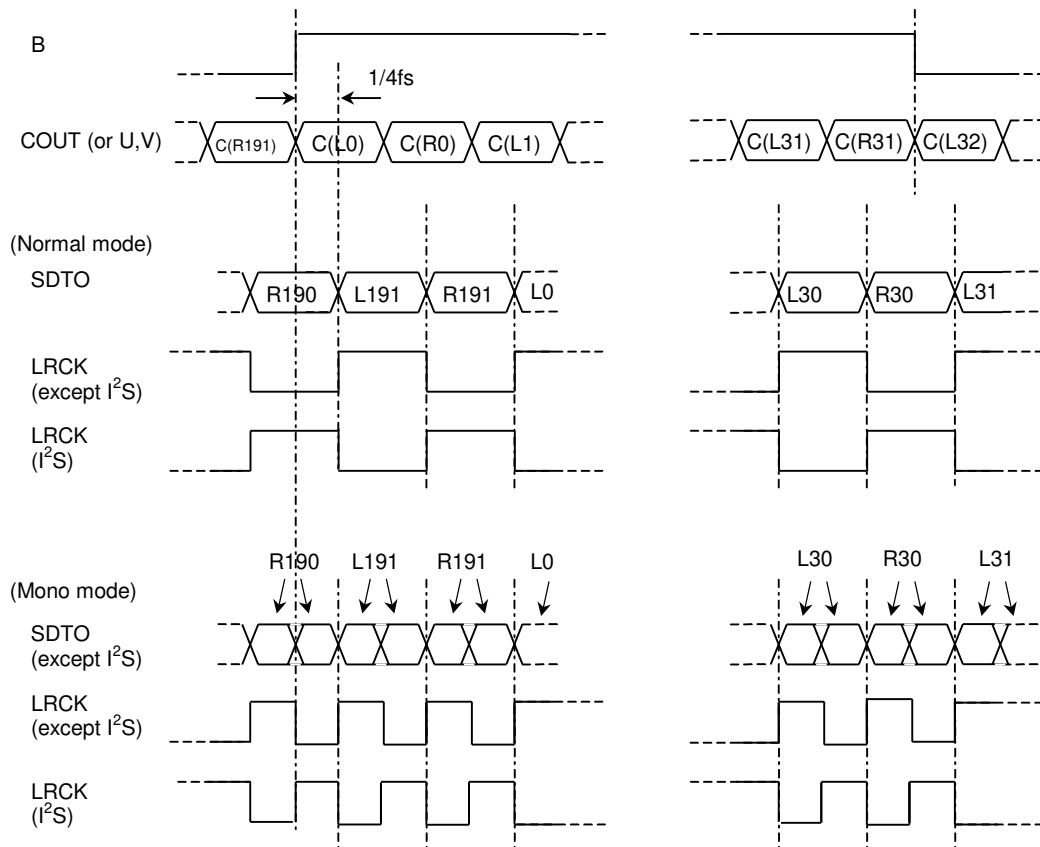

Figure 13. B, C, U, V output timings

■ Biphase Output

The AK4118A outputs the data either through output (from DIR) or transmitted output (DIT; the data from DAUX is transformed to IEC60958 format.) from TX1/0 pins. It is selected by DIT bit. The source of the data through output from the TX0 pin is selected among RX0-8 by OPS00, 01 and 02 bits, and selected by OPS10, 11 and 12 bits for the TX1 pin respectively. When the AK4118A outputs DAUX data, V bit is controlled by the VIN pin and first 5 bytes of C bit can be controlled by CT39-CT0 bits in control registers (Figure 14). When bit0=“0”(consumer mode), bit20-23(Audio channel) can not be controlled directly but can be controlled by CT20 bit. When the CT20 bit is “1”, the AK4118A outputs “1000” at C20-23 for sub frame 1(left channel) and output “0100” at C20-23 for sub frame 2 (right channel) automatically. When CT20 bit is “0”, the AK4118A outputs “0000”. U bits are controlled by UDIT bit as follows; When UDIT bit is “0”, U bits are always “0”. When UDIT bit is “1”, the recovered U bits are used for DIT(DIR-DIT loop mode of U bit). This mode is only available when PLL is locked in the master mode.

OPS02	OPS01	OPS00	Output Data
0	0	0	RX0
0	0	1	RX1
0	1	0	RX2
0	1	1	RX3
1	0	0	RX4
1	0	1	RX5
1	1	0	RX6
1	1	1	RX7

(default)

Table 13. Output Data Select for TX0

DIT	OPS12	OPS11	OPS10	Output Data
0	0	0	0	RX0
0	0	0	1	RX1
0	0	1	0	RX2
0	0	1	1	RX3
0	1	0	0	RX4
0	1	0	1	RX5
0	1	1	0	RX6
0	1	1	1	RX7
1	x	x	x	DAUX

(default)

(x: Don't care)

Table 14. Output Data Select for TX1

(Normal mode)

(Mono mode)

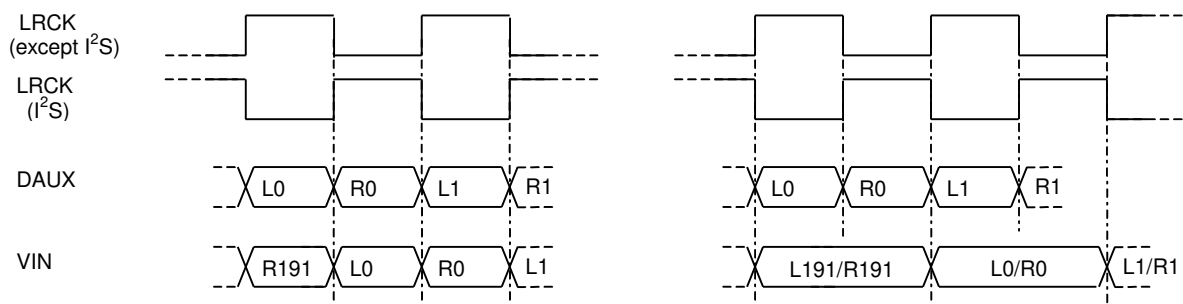

Figure 14. DAUX and VIN input timings

■ Double Sampling Frequency Mode

When MONO bit = “1”, the AK4118A outputs data in double speed according to “Single channel double sampling frequency mode” of AES3. For example, when 192kHz mono data is transmitted or received, L/R channels of 96kHz biphase data are used. In this case, one frame is 96kHz and LRCK frequency is 192kHz.

1) RX

When MONO bit = “1”, the AK4118A outputs mono data from SDTO as follows.

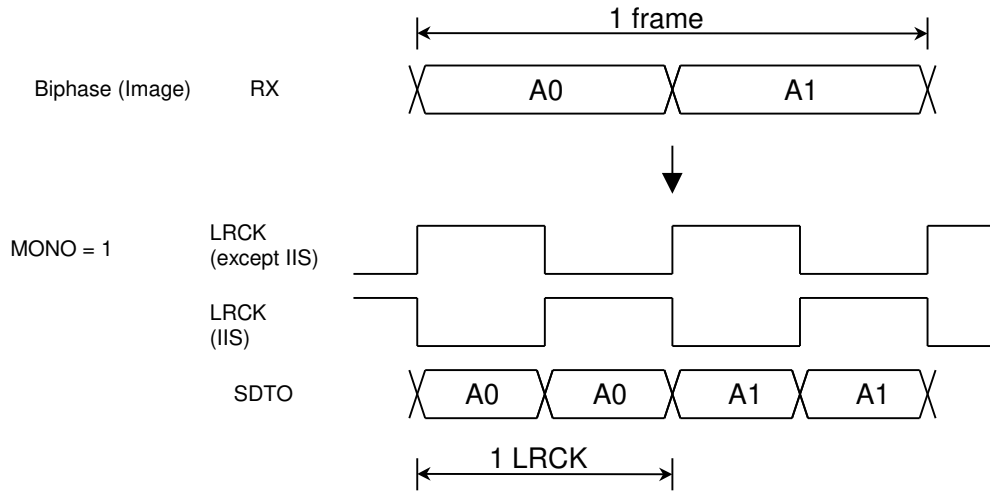

Figure 15. MONO Mode (RX)

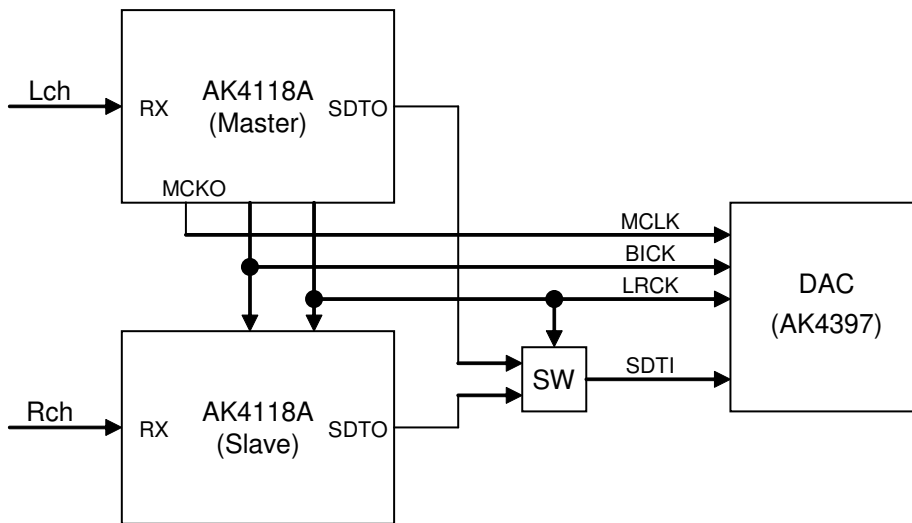

Figure 16. MONO mode Connection Example (RX)

2) TX

When MONO bit = "1" and TLR bit = "0", the AK4118A outputs Lch data through TX1 as biphasic signal. When MONO bit = "1" and TLR bit = "1", then Rch data is output.

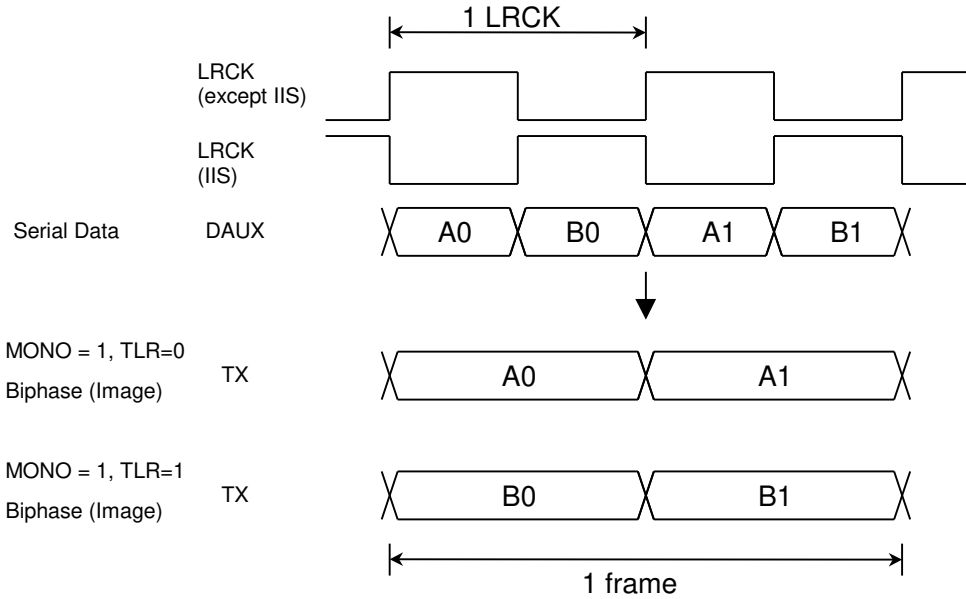

Figure 17. MONO Mode (TX)

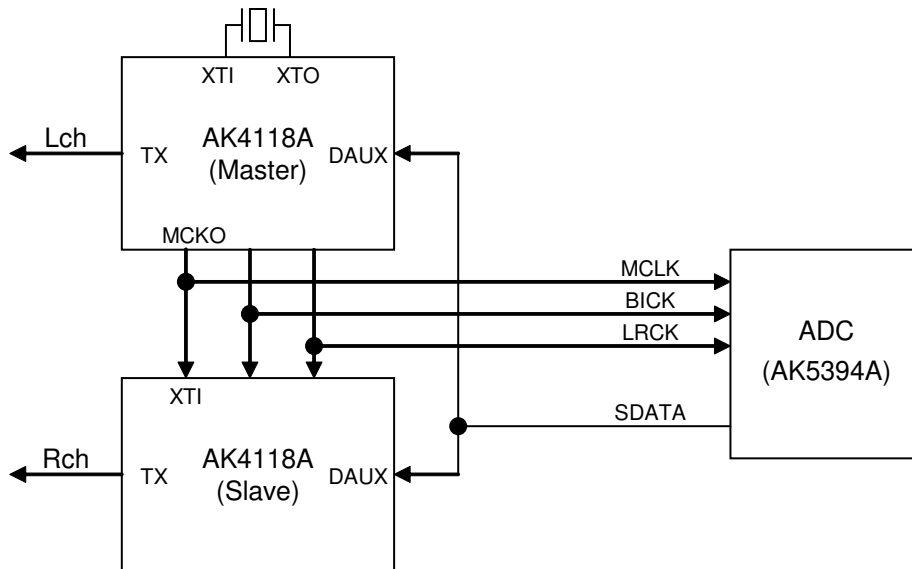
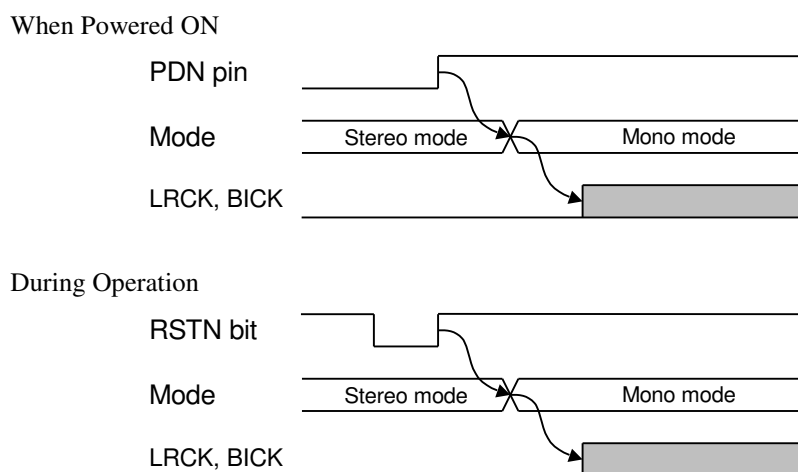

Figure 18. MONO Mode Connection Example (TX)

Note: In case of the connection example (Figure 18) or when more than one AK4118A's are used, LRCK and BICK should be input after reset so that the phase of TX outputs is aligned. The AK4118A's should be set by following sequence (Figure 19).



- (1) Reset all the AK4118A's by the PDN pin = "L" → "H" or RSTN bit = "0" → "1".
- (2) Set all the AK4118A's to MONO mode while they are still in slave mode.
- (3) Set one of the AK4118A to master mode so that LRCK is input to all other AK4118A's at the same time, or Input LRCK externally to all the AK4118A's at the same time.

Figure 19. MONO Mode Setup Sequence (TX)

■ Biphase Signal Input/Output Circuit

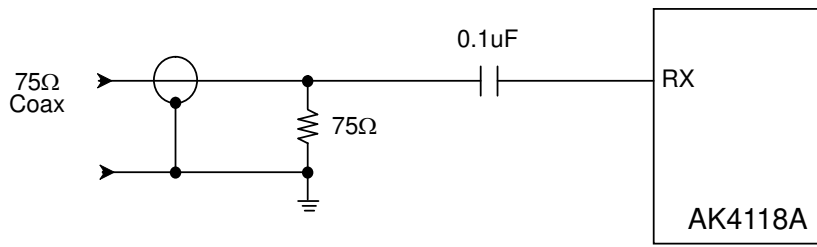

Figure 20. Consumer Input Circuit (Coaxial Input)

Note: In case of coaxial input, if a coupling level to this input from the next RX input line pattern exceeds 50mV, there is a possibility to occur an incorrect operation is occurred. In this case, it is possible to lower the coupling level by adding this decoupling capacitor.

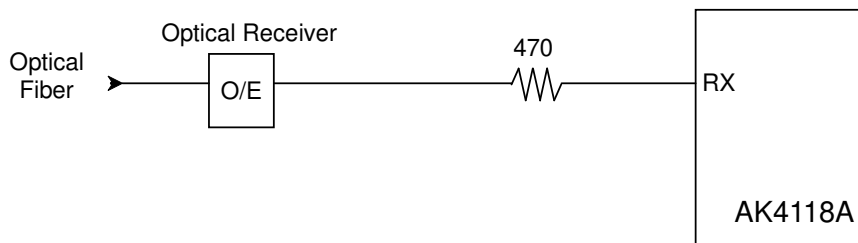

Figure 21. Consumer Input Circuit (Optical Input)

For coaxial input, as the input level of RX line is small in Serial Mode, cross-talking among RX input lines have to be avoided. For example, inserting the shield pattern among them is effective. In Parallel Mode, four channel inputs (RX0/1/2/3) are available and RX4-7 change to other pins for audio format control. Those pins must be fixed to “H” or “L”.

The AK4118A includes the TX output buffer. The output level meets 0.5V+/-20% using the external resistors. The T1 in the Figure 22 is a transformer of 1:1.

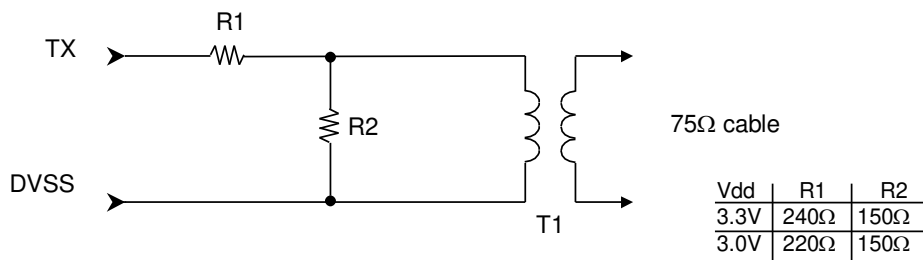
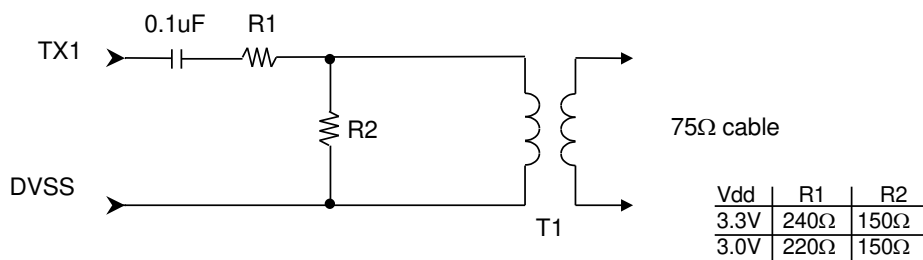

Figure 22. TX External Resistor Network

Note: When the AK4118A is in the power-down mode (PDN pin= “L”), power supply current can be suppressed by using AC couple capacitor as following figure since the TX1 pin output becomes uncertain at power-down mode.



■ Q-subcode Buffers

The AK4118A has Q-subcode buffer for CD application. The AK4118A takes Q-subcode into registers in following conditions.

1. The sync word (S0,S1) is constructed at least 16 “0”s.
2. The start bit is “1”.
3. Those 7bits Q-W follows to the start bit.
4. The distance between two start bits are 8-16 bits.

The QINT bit in the control register goes “1” when the new Q-subcode differs from old one, and goes “0” when QINT bit is read.

	1	2	3	4	5	6	7	8	*
S0	0	0	0	0	0	0	0	0	0...
S1	0	0	0	0	0	0	0	0	0...
S2	1	Q2	R2	S2	T2	U2	V2	W2	0...
S3	1	Q3	R3	S3	T3	U3	V3	W3	0...
:	:	:	:	:	:	:	:	:	:
S97	1	Q97	R97	S97	T97	U97	V97	W97	0...
S0	0	0	0	0	0	0	0	0	0...
S1	0	0	0	0	0	0	0	0	0...
S2	1	Q2	R2	S2	T2	U2	V2	W2	0...
S3	1	Q3	R3	S3	T3	U3	V3	W3	0...
:	:	:	:	:	:	:	:	:	:

↑ (*) number of "0" : min=0; max=8.
Q

Figure 23. Configuration of U- bit (CD)

Q2	Q3	Q4	Q5	Q6	Q7	Q8	Q9	Q10	Q11	Q12	Q13	Q14	Q15	Q16	Q17	Q18	Q19	Q20	Q21	Q22	Q23	Q24	Q25
CTRL				ADRS				TRACK NUMBER								INDEX							
Q26	Q27	Q28	Q29	Q30	Q31	Q32	Q33	Q34	Q35	Q36	Q37	Q38	Q39	Q40	Q41	Q42	Q43	Q44	Q45	Q46	Q47	Q48	Q49
MINUTE						SECOND								FRAME									
Q50	Q51	Q52	Q53	Q54	Q55	Q56	Q57	Q58	Q59	Q60	Q61	Q62	Q63	Q64	Q65	Q66	Q67	Q68	Q69	Q70	Q71	Q72	Q73
ZERO						ABSOLUTE MINUTE								ABSOLUTE SECOND									
Q74	Q75	Q76	Q77	Q78	Q79	Q80	Q81	Q82	Q83	Q84	Q85	Q86	Q87	Q88	Q89	Q90	Q91	Q92	Q93	Q94	Q95	Q96	Q97
ABSOLUTE FRAME								CRC $G(x)=x^{16}+x^{12}+x^5+1$															

Figure 24. Q-subcode

Addr	Register Name	D7	D6	D5	D4	D3	D2	D1	D0
16H	Q-subcode Address / Control	Q9	Q8	Q3	Q2
17H	Q-subcode Track	Q17	Q16	Q11	Q10
18H	Q-subcode Index
19H	Q-subcode Minute
1AH	Q-subcode Second
1BH	Q-subcode Frame
1CH	Q-subcode Zero
1DH	Q-subcode ABS Minute
1EH	Q-subcode ABS Second
1FH	Q-subcode ABS Frame	Q81	Q80	Q75	Q74

Figure 25. Q-subcode register

■ Error Handling

The following nine events cause the INT0 and INT1 pins to show the status of the interrupt condition. When the PLL is OFF (Clock Operation Mode 1), INT0 and INT1 pins go to “L”.

1. UNLCK : PLL unlock state detect
“1” when the PLL loses lock. The AK4118A loses lock when the distance between two preamble is not correct or when those preambles are not correct.
2. PAR : Parity error or bi-phase coding error detection
“1” when parity error or bi-phase coding error is detected, updated every sub-frame cycle.
3. AUTO : Non-Linear PCM or DTS-CD Bit Stream detection
The OR function of NPCM and DTSCD bits is available at the AUTO bit.
4. V : Validity flag detection
“1” when validity flag is detected. Updated every sub-frame cycle.
5. AUDION : Non-audio detection
“1” when the “AUDION” bit in recovered channel status indicates “1”. Updated every block cycle.
6. STC : Sampling frequency or pre-emphasis information change detection
When either FS3-0 bit or PEM bit is changed, it maintains “1” during 1 sub-frame.
7. QINT : U-bit Sync flag
“1” when the Q-subcode differs from the old one. Updated every sync code cycle for Q-subcode.
8. CINT : Channel status sync flag
“1” when received C bit differs from the old one. Updated every block cycle.
9. DAT : DAT Start ID detect
“1” when the category code indicates “DAT” and “DAT Start ID” is detected. When DCNT bit is “1”, it does not indicate “1” even if “DAT Start ID” is detected again within “3841 x LRCK”.
When “DAT Start ID” is detected again after “3840 x LRCK” passed, it indicates “1”. When DCNT bit is “0”, it indicates “1” every “DAT Start ID” detection.

1. Parallel control mode

In parallel control mode, the INT0 pin outputs the ORed signal between UNLCK and PAR. The INT1 pin outputs the ORed signal between AUTO and AUDION. Once the INT0 pin goes to “H”, it maintains “H” for 1024/fs cycles after the all error events are removed. Table 15 shows the state of each output pins when the INT0/1 pin is “H”.

Event				Pin			
UNLCK	PAR	AUTO	AUDION	INT0	INT1	SDTO	V
1	x	x	x	H	Note 14	L	L
0	1	x	x			Previous Data	Output
0	0	x	x	L		Output	Output
x	x	1	x	Note 15	H	Note 16	Note 17
x	x	x	1				
x	x	0	0		L		

Note 14. The INT1 pin outputs “L” or “H” in accordance with the ORed signal between AUTO and AUDION.

Note 15. The INT0 pin outputs “L” or “H” in accordance with the ORed signal between UNLCK and PAR.

Note 16. The SDTO pin outputs “L”, “Previous Data” or “Normal Data” in accordance with the ORed signal between UNLCK and PAR.

Note 17. The VIN pin outputs “L” or “Normal operation” in accordance with the ORed signal between PAR and UNCLK.

Table 15. Error Handling in parallel control mode (x: Don't care)

2. Serial control mode

In serial control mode, the INT1 and INT0 pins output an ORed signal based on the above nine interrupt events. When masked, the interrupt event does not affect the operation of the INT1-0 pins (the masks do not affect the registers in 07H and DAT bit). Once the INT0 pin goes to “H”, it remains “H” for 1024/fs (this value can be changed with the EFH1-0 bits) after all events not masked by mask bits are cleared. The INT1 pin immediately goes to “L” when those events are cleared.

UNLCK, PAR, AUTO, AUDION and V bits in Address=07H indicate the interrupt status events above in real time. Once QINT, CINT and DAT bits goes to “1”, it stays “1” until the register is read.

When the AK4118A loses lock, the channel status bit, user bit, Pc and Pd are initialized. In this initial state, The INT0 pin outputs the ORed signal between UNLCK and PAR bits. The INT1 pin outputs the ORed signal between AUTO and AUDION bits.

Event			Pin		
UNLCK	PAR	Others	SDTO	V	TX
1	x	x	L	L	Output
0	1	x	Previous Data	Output	Output
x	x	x	Output	Output	Output

Table 16. Error Handling in serial control mode (x: Don't care)

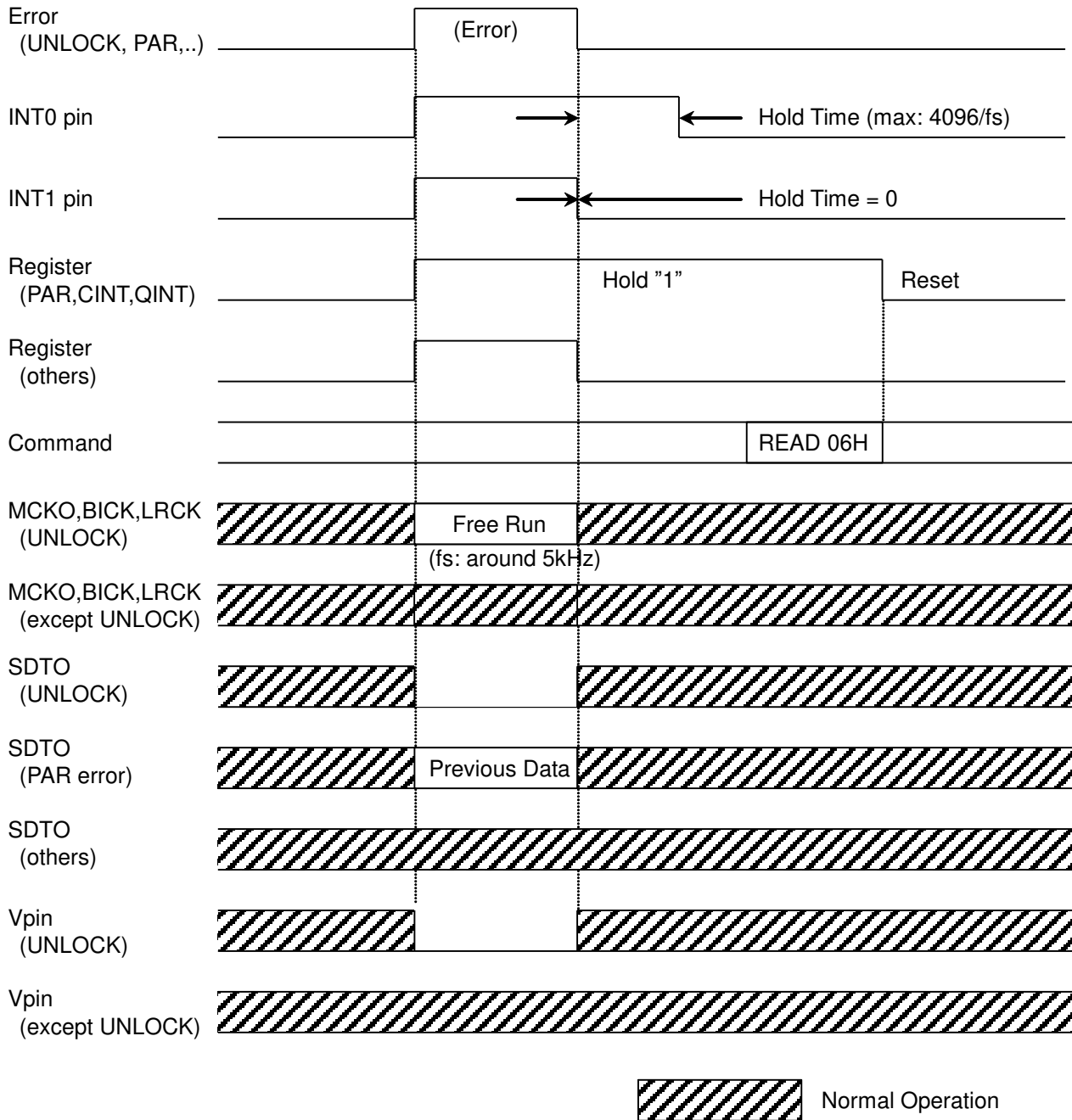

Figure 26. INT0/1 pin Timing

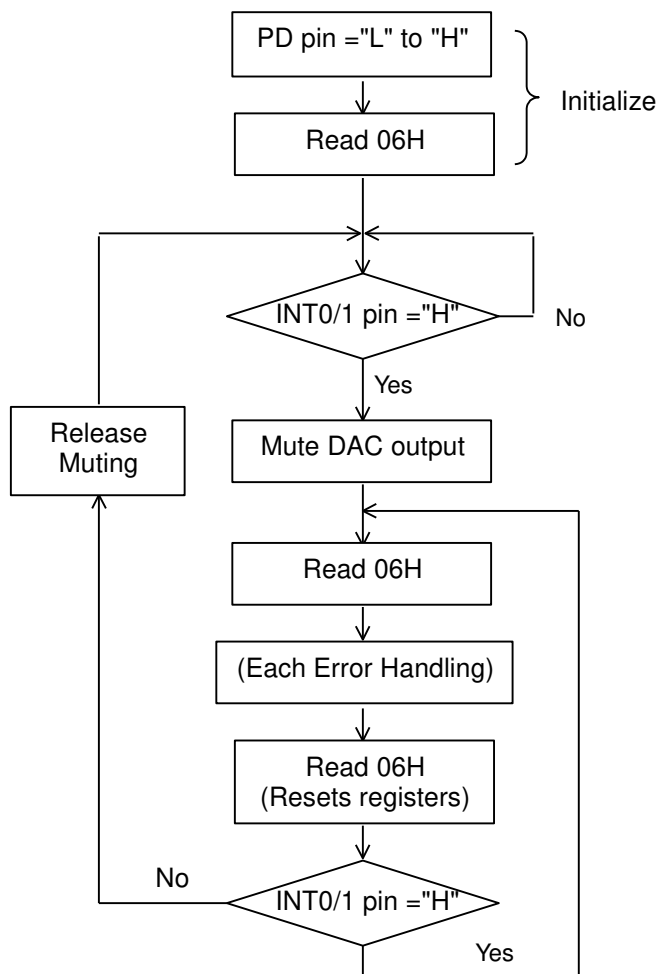

Figure 27. Error Handling Sequence Example 1

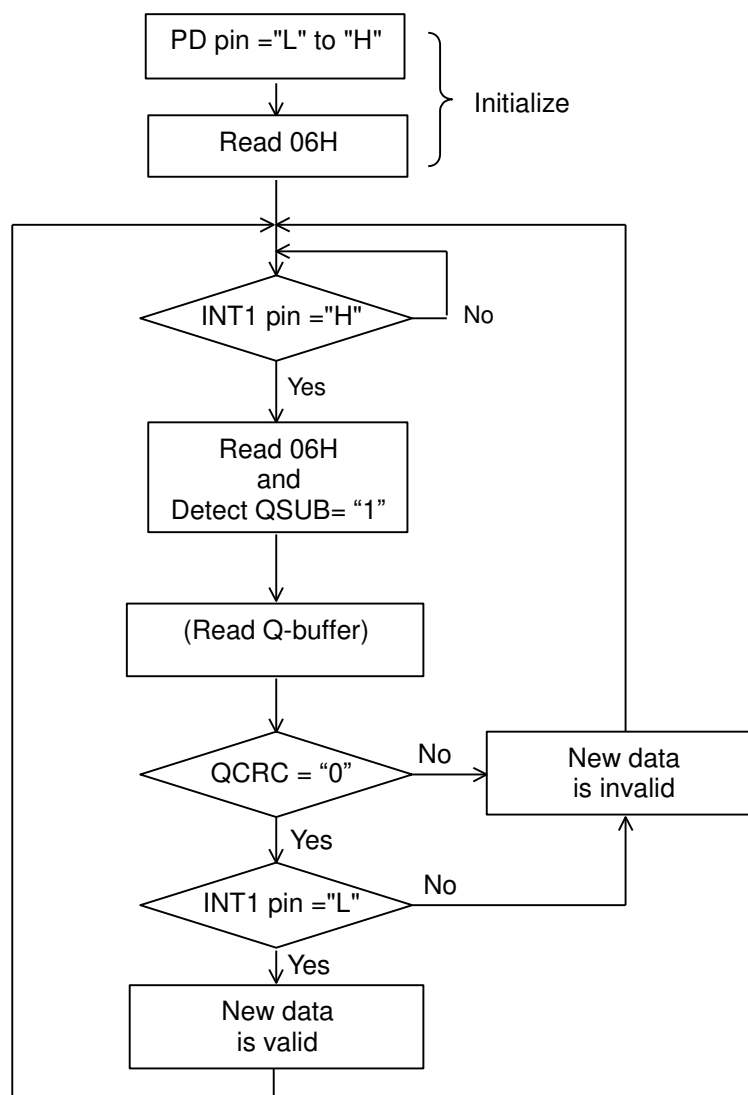

Figure 28. Error Handling Sequence Example (for Q/CINT)

■ Audio Serial Interface Format

The DIF0, DIF1 and DIF2 pins can select eight serial data formats as shown in Table 17. In all formats the serial data is MSB-first, 2's complement format. The SDTO is clocked out on the falling edge of BICK and the DAUX is latched on the rising edge of BICK. BICK outputs 64fs clock in Mode 0-5. Mode 6-7 are Slave Modes, and BICK is available up to 128fs at fs=48kHz. In the format equal or less than 20bit (Mode0-2), LSBs in sub-frame are truncated. In Mode 3-7, the last 4LSBs are auxiliary data (Figure 29).

When the Parity Error occurs in a sub-frame, the AK4118A continues to output the last normal sub-frame data from SDTO repeatedly until the error is removed. When the Unlock Error occurs, the AK4118A outputs "0" data from the SDTO pin. In case of using the DAUX pin, the data is transformed and output from SDTO. The DAUX pin is used in Clock Operation Mode 1/3 and unlock state of Mode 2.

The input data format to DAUX should be left justified except in Mode5 and Mode7 (Table 17). In Mode5 or Mode7, both the input data format of DAUX and output data format of SDTO are I²S. Mode6 and Mode7 are Slave Mode that is corresponding to the Master Mode of Mode4 and Mode5. In salve Mode, LRCK and BICK should be fed with synchronizing to MCKO1/2.

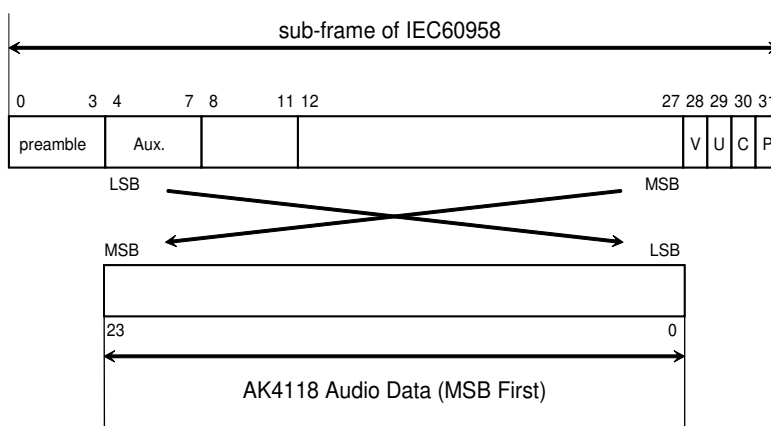

Figure 29. Bit Configuration

Mode	DIF2	DIF1	DIF0	DAUX	SDTO	LRCK		BICK	
							I/O		I/O
0	0	0	0	24bit, Left justified	16bit, Right justified	H/L	O	64fs	O
1	0	0	1	24bit, Left justified	18bit, Right justified	H/L	O	64fs	O
2	0	1	0	24bit, Left justified	20bit, Right justified	H/L	O	64fs	O
3	0	1	1	24bit, Left justified	24bit, Right justified	H/L	O	64fs	O
4	1	0	0	24bit, Left justified	24bit, Left justified	H/L	O	64fs	O
5	1	0	1	24bit, I ² S	24bit, I ² S	L/H	O	64fs	O
6	1	1	0	24bit, Left justified	24bit, Left justified	H/L	I	64-128fs	I
7	1	1	1	24bit, I ² S	24bit, I ² S	L/H	I	64-128fs	I

(default)

Table 17. Audio Data Format

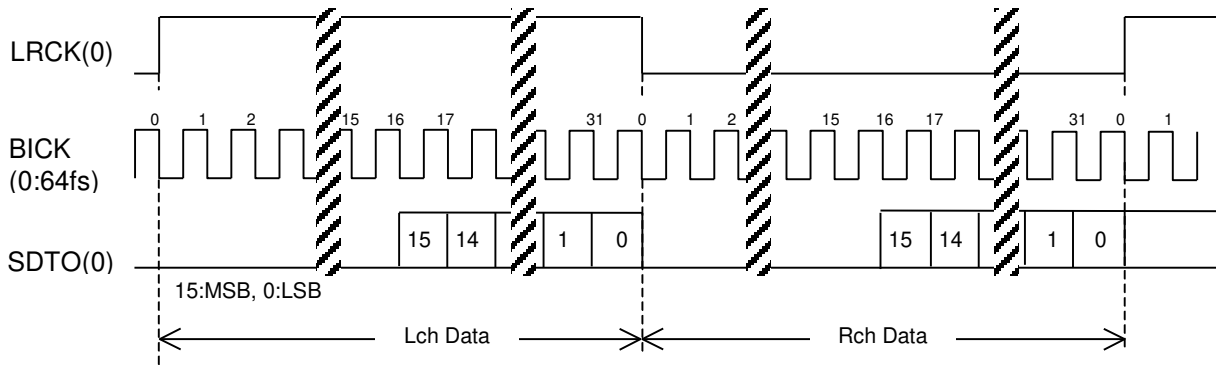

Figure 30. Mode 0 Timing

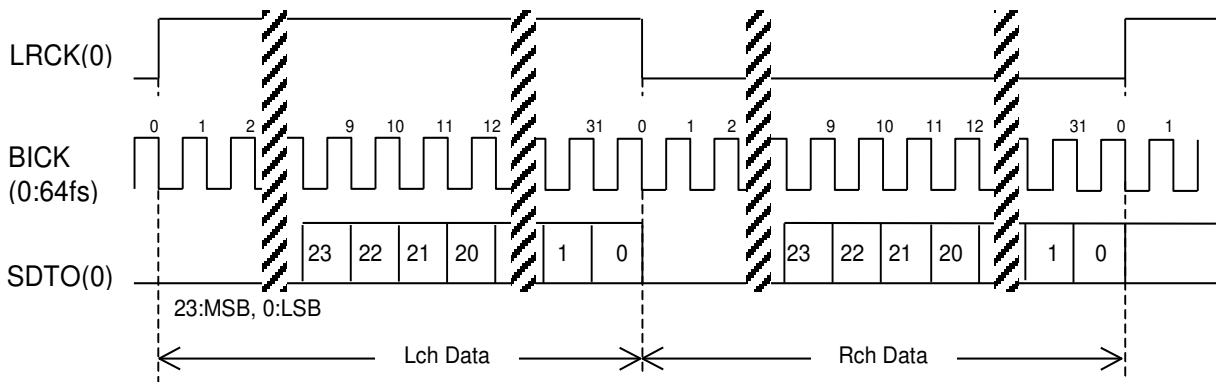

Figure 31. Mode 3 Timing

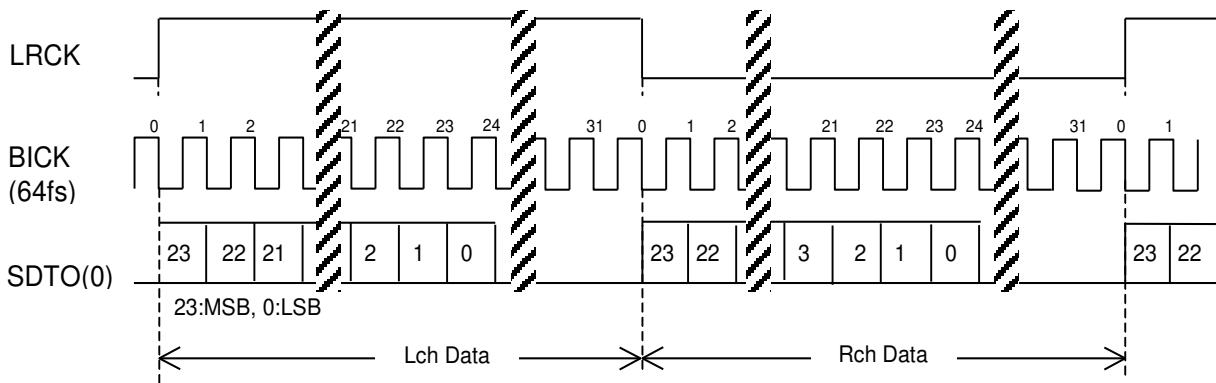

Figure 32. Mode 4/6 Timing

Mode4: LRCK, BICK (Output)
Mode6: LRCK, BICK (Input)

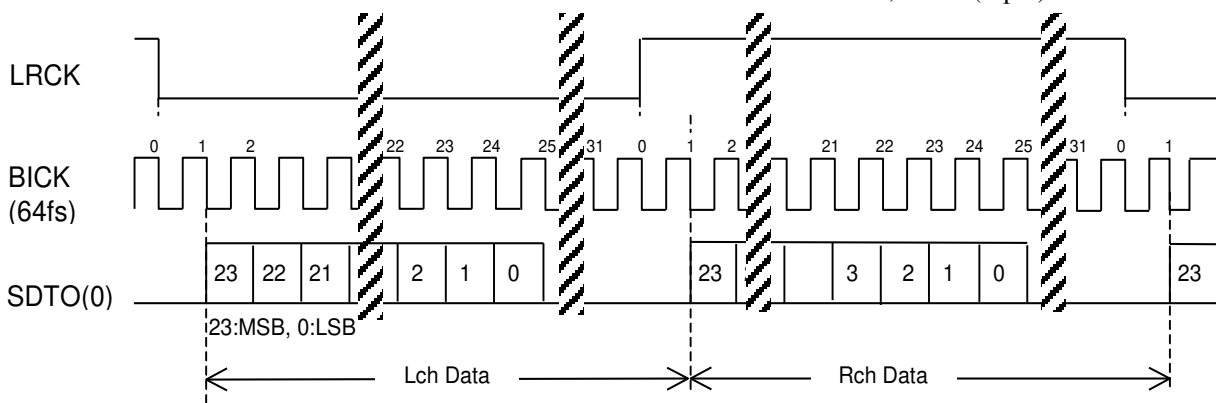

Figure 33. Mode 5/7 Timing

Mode5: LRCK, BICK (Output)
Mode7: LRCK, BICK (Input)

■ GPIO Controller

The AK4118A has 8 input/output port pins. Set GP0~GP7 pins by GPDR register for data direction, GPSCR register for the pin level setting and GPLR register for pin level reading. Table 18 ~ Table 21 show the pin state at setting or internal node state of GPIO registers, BCU bit, TX1E/TX0E bit and VIN E bit.

VIN GP0

Register Setting				Register Read	Internal Node	Pin State	VIN GP0 pin
VINE	GPE	GPDR	GPSCR	GPLR	VIN I		
1	x	x	x	L	VIN	I	VIN
0	x	0	x	GPI	L	I	GPI
0	x	1	Valid	GPSCR	L	O	GPSCR

Table 18. VINGP0 pin and Internal Statement (x: Don't care)

GP1

Register Setting			Register Read	Pin State	GP1 pin
GPE	GPDR	GPSCR	GPLR		
x	0	x	GPI	I	GPI
x	1	x	GPSCR	O	GPSCR

Table 19. GP1 pin and Internal Statement (x: Don't care)

TX0/1 GP2/3

Register Setting				Register Read	Pin State	TX GP pin
TX E	GPE	GPDR	GPSCR	GPLR		
1	x	x	x	L	O	RX
0	0	x	x	L	O	L
0	1	0	x	GPI	I	GPI
0	1	1	Valid	GPSCR	O	GPSCR

Table 20. TX0/1 GP2/3 pin and Internal Statement (x: Don't care)

B/C/U/VOUT GP4/5/6/7

Register Setting				Register Read	Pin State	BCUV GP pin
BCU	GPE	GPDR	GPSCR	GPLR		
1	x	x	x	L	O	BCUV OUT
0	0	x	x	Data Hold	O	L
0	1	0	x	GPI	I	GPI
0	1	1	Valid	GPSCR	O	GPSCR

Table 21. B/C/U/VOUT GP4/5/6/7 pin and Internal Statement (x: Don't care)

■ Serial Control Interface

(1). 4-wire serial control mode (IIC pin= "L")

The internal registers may be either written or read by the 4-wire μ P interface pins: CSN, CCLK, CDTI & CDTO. The data on this interface consists of Chip address (1bit, C1 is fixed to "0"), Read/Write (1bit), Register address (MSB first, 5bits) and Control data (MSB first, 8bits). Address and data is clocked in on the rising edge of CCLK and data is clocked out on the falling edge. For write operations, data is latched after the 16th rising edge of CCLK, after a high-to-low transition of CSN. For read operations, the CDTO output goes high impedance after a low-to-high transition of CSN. The maximum speed of CCLK is 5MHz. The PDN pin= "L" resets the registers to their default values. When the state of PSN pin is changed, the AK4118A should be reset by the PDN pin= "L".

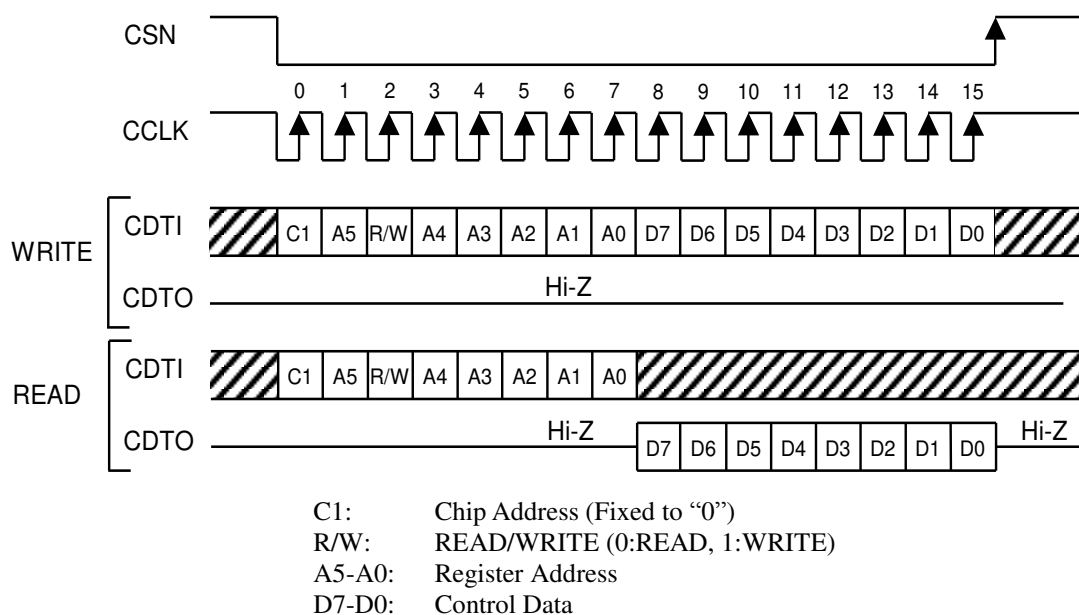

Figure 34. 4-wire Serial Control I/F Timing

(2). I²C bus control mode (IIC pin= "H")

The AK4118A supports High speed mode I²C-bus (max: 400kHz).

(2)-1. Data transfer

In order to access any IC devices on the I²C BUS, input a start condition first, followed by a single Slave address that includes the Device Address. IC devices on the BUS compare this Slave address with their own addresses and the IC device that has identical address with the Slave-address generates an acknowledgement. An IC device with the identical address executes either a read or write operation. After the command execution, input Stop condition.

(2)-1-1. Data Change

Change the data on the SDA line while SCL line is "L". SDA line condition must be stable and fixed while the clock is "H". Change the Data line condition between "H" and "L" only when the clock signal on the SCL line is "L". Change the SDA line condition while SCL line is "H" only when the start condition or stop condition is input.

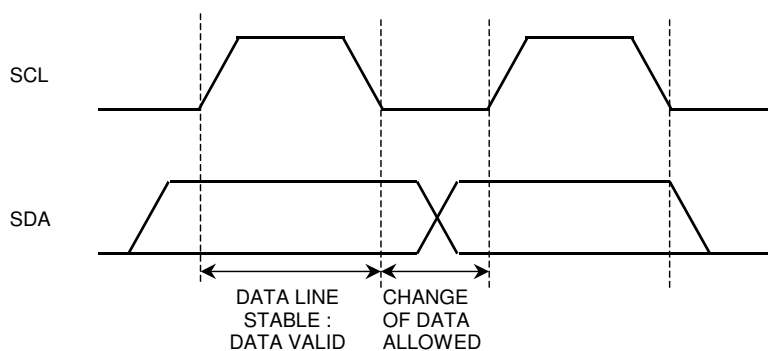

Figure 35. Data Transfer

(2)-1-2. START and STOP condition

Start condition is generated by the transition of "H" to "L" on the SDA line while the SCL line is "H". All instructions are initiated by Start condition. Stop condition is generated by the transition of "L" to "H" on SDA line while SCL line is "H". All instructions end by Stop condition.

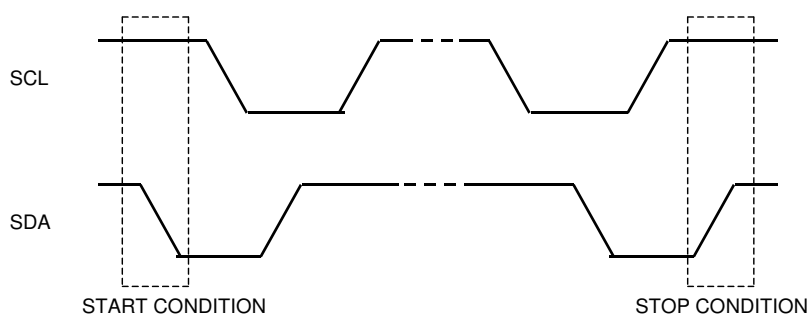

Figure 36. START and STOP condition

(2)-1-3. Acknowledge

An external device that is sending data to the AK4118A releases the SDA line (“H”) after receiving one-byte of data. An external device that receives data from the AK4118A then sets the SDA line to “L” at the next clock. This operation is called “acknowledgement”, and it enables verification that the data transfer has been properly executed. The AK4118A generates an acknowledgement upon receipt of Start condition and Slave address. For a write instruction, an acknowledgement is generated whenever receipt of each byte is completed. For a read instruction, succeeded by generation of an acknowledgement, the AK4118A releases the SDA line after outputting data at the designated address, and it monitors the SDA line condition. When the Master side generates an acknowledgement without sending a Stop condition, the AK4118A outputs data at the next address location. When no acknowledgement is generated, the AK4118A ends data output (not acknowledged).

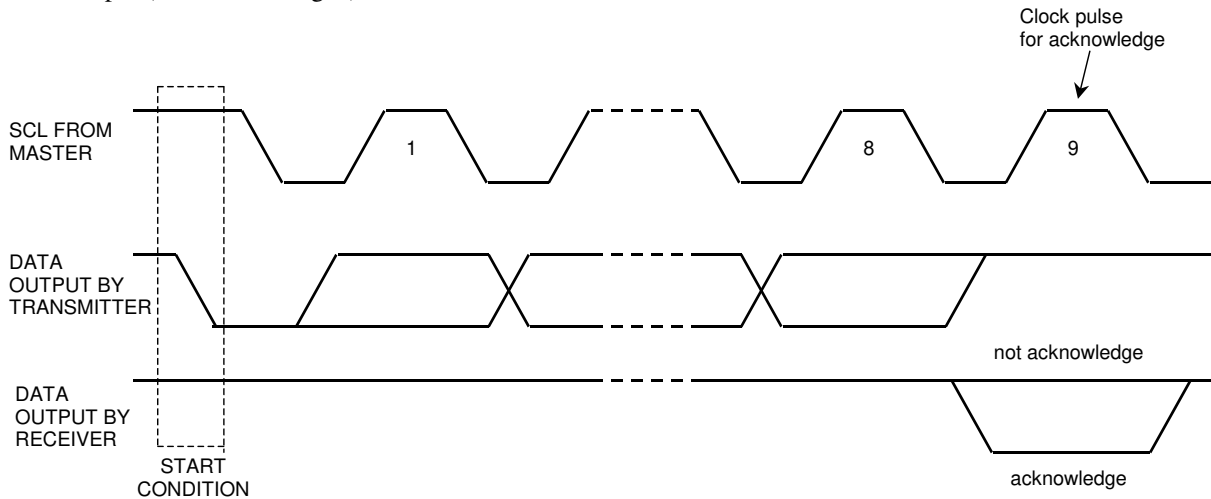
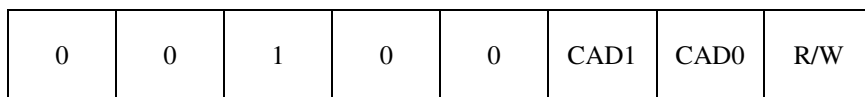

Figure 37. Acknowledge on the I²C-bus

(2)-1-4. The First Byte

The First Byte which includes the Slave-address is input after the Start condition is set, and a target IC device that will be accessed on the bus is selected by the Slave-address. The Slave-address is configured with the upper 7-bits. Data of the upper 5-bits is “00100”. The next 2 bits are address bits that select the desired IC which are set by the CAD1 and CAD0 pins. When the Slave-address is inputted, an external device that has the identical device address generates an acknowledgement and instructions are then executed. The 8th bit of the First Byte (lowest bit) is allocated as the R/W Bit. When the R/W Bit is “1”, the read instruction is executed, and when it is “0”, the write instruction is executed.



(Those CAD1/0 should match with CAD1/0 pins.)

Figure 38. The First Byte

(2)-2. WRITE Operations

Set R/W bit = "0" for the WRITE operation of the AK4118A.

After receipt the start condition and the first byte, the AK4118A generates an acknowledge, and awaits the second byte (register address). The second byte consists of the address for control registers of the AK4118A. The format is MSB first, and those most significant 3-bits are "Don't care".

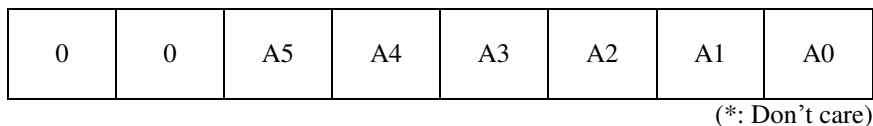

Figure 39. The Second Byte

After receipt the second byte, the AK4118A generates an acknowledge, and awaits the third byte. Those data after the second byte contain control data. The format is MSB first, 8bits.

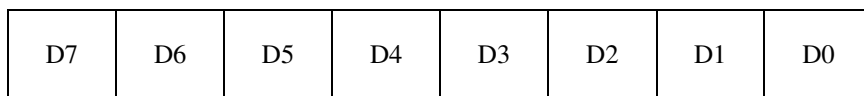

Figure 40. Byte structure after the second byte

The AK4118A is capable of more than one byte write operation in one sequence.

After receipt of the third byte, the AK4118A generates an acknowledge, and awaits the next data again. The master can transmit more than one words instead of terminating the write cycle after the first data word is transferred. After the receipt of each data, the internal 5bits address counter is incremented by one, and the next data is taken into next address automatically. If the address exceed 1FH prior to generating the stop condition, the address counter will "roll over" to 00H and the previous data will be overwritten.

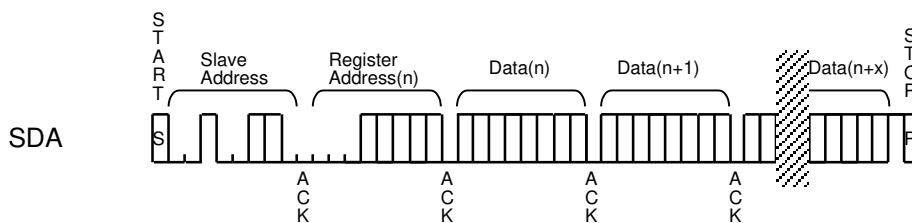

Figure 41. WRITE Operation

(2)-3. READ Operations

Set R/W bit = "1" for the READ operation of the AK4118A.

After transmission of a data, the master can read next address's data by generating the acknowledge instead of terminating the write cycle after the receipt the first data word. After the receipt of each data, the internal 5bits address counter is incremented by one, and the next data is taken into next address automatically. If the address exceed 1FH prior to generating the stop condition, the address counter will "roll over" to 00H and the previous data will be overwritten.

The AK4118A supports two basic read operations: CURRENT ADDRESS READ and RANDOM READ.

(2)-3-1. CURRENT ADDRESS READ

The AK4118A contains an internal address counter that maintains the address of the last word accessed, incremented by one. Therefore, if the last access (either a read or write) was to address "n", the next CURRENT READ operation would access data from the address "n+1".

After receipt of the slave address with R/W bit set to "1", the AK4118A generates an acknowledge, transmits 1byte data which address is set by the internal address counter and increments the internal address counter by 1. If the master does not generate an acknowledge but generate the stop condition, the AK4118A discontinues transmission.

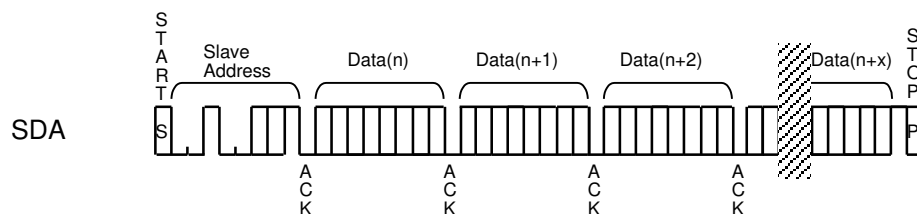

Figure 42. CURRENT ADDRESS READ

(2)-3-2. RANDOM READ

Random read operation allows the master to access any memory location at random. Prior to issuing the slave address with the R/W bit set to "1", the master must first perform a "dummy" write operation.

The master issues start condition, slave address(R/W="0") and then the register address to read. After the register address's acknowledge, the master immediately reissues start condition and the slave address with the R/W bit set to "1". Then the AK4118A generates an acknowledge, 1byte data and increments the internal address counter by 1. If the master does not generate an acknowledge but generate the stop condition, the AK4118A discontinues transmission.

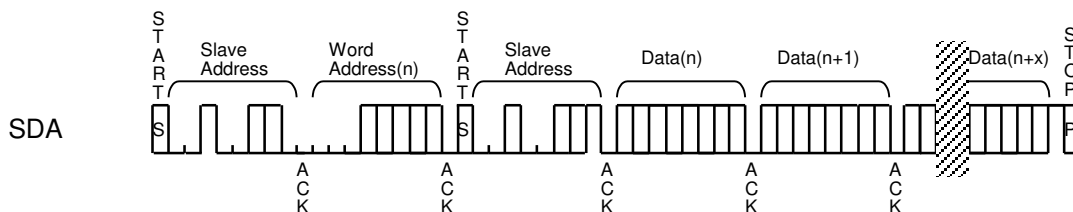

Figure 43. RANDOM READ

■ Register Map

Addr	Register Name	D7	D6	D5	D4	D3	D2	D1	D0
00H	CLK & Power Down Control	CS12	BCU	CM1	CM0	OCKS1	OCKS0	PWN	RSTN
01H	Format & De-em Control	MONO	DIF2	DIF1	DIF0	DEAU	DEM1	DEM0	DFS
02H	Input/ Output Control 0	TX1E	OPS12	OPS11	OPS10	TX0E	OPS02	OPS01	OPS00
03H	Input/ Output Control 1	EFH1	EFH0	UDIT	TLR	DIT	IPS2	IPS1	IPS0
04H	INT0 MASK	MQIT0	MAUT0	MCIT0	MULK0	MDTS0	MPE0	MAUD0	MPAR0
05H	INT1 MASK	MQIT1	MAUT1	MCIT1	MULK1	MDTS1	MPE1	MAUD1	MPAR1
06H	Receiver status 0	QINT	AUTO	CINT	UNLCK	DTSCD	PEM	AUDION	PAR
07H	Receiver status 1	FS3	FS2	FS1	FS0	0	V	QCRC	CCRC
08H	RX Channel Status Byte 0	CR7	CR6	CR5	CR4	CR3	CR2	CR1	CR0
09H	RX Channel Status Byte 1	CR15	CR14	CR13	CR12	CR11	CR10	CR9	CR8
0AH	RX Channel Status Byte 2	CR23	CR22	CR21	CR20	CR19	CR18	CR17	CR16
0BH	RX Channel Status Byte 3	CR31	CR30	CR29	CR28	CR27	CR26	CR25	CR24
0CH	RX Channel Status Byte 4	CR39	CR38	CR37	CR36	CR35	CR34	CR33	CR32
0DH	TX Channel Status Byte 0	CT7	CT6	CT5	CT4	CT3	CT2	CT1	CT0
0EH	TX Channel Status Byte 1	CT15	CT14	CT13	CT12	CT11	CT10	CT9	CT8
0FH	TX Channel Status Byte 2	CT23	CT22	CT21	CT20	CT19	CT18	CT17	CT16
10H	TX Channel Status Byte 3	CT31	CT30	CT29	CT28	CT27	CT26	CT25	CT24
11H	TX Channel Status Byte 4	CT39	CT38	CT37	CT36	CT35	CT34	CT33	CT32
12H	Burst Preamble Pc Byte 0	PC7	PC6	PC5	PC4	PC3	PC2	PC1	PC0
13H	Burst Preamble Pc Byte 1	PC15	PC14	PC13	PC12	PC11	PC10	PC9	PC8
14H	Burst Preamble Pd Byte 0	PD7	PD6	PD5	PD4	PD3	PD2	PD1	PD0
15H	Burst Preamble Pd Byte 1	PD15	PD14	PD13	PD12	PD11	PD10	PD9	PD8
16H	Q-subcode Address / Control	Q9	Q8	Q7	Q6	Q5	Q4	Q3	Q2
17H	Q-subcode Track	Q17	Q16	Q15	Q14	Q13	Q12	Q11	Q10
18H	Q-subcode Index	Q25	Q24	Q23	Q22	Q21	Q20	Q19	Q18
19H	Q-subcode Minute	Q33	Q32	Q31	Q30	Q29	Q28	Q27	Q26
1AH	Q-subcode Second	Q41	Q40	Q39	Q38	Q37	Q36	Q35	Q34
1BH	Q-subcode Frame	Q49	Q48	Q47	Q46	Q45	Q44	Q43	Q42
1CH	Q-subcode Zero	Q57	Q56	Q55	Q54	Q53	Q52	Q51	Q50
1DH	Q-subcode ABS Minute	Q65	Q64	Q63	Q62	Q61	Q60	Q59	Q58
1EH	Q-subcode ABS Second	Q73	Q72	Q71	Q70	Q69	Q68	Q67	Q66
1FH	Q-subcode ABS Frame	Q81	Q80	Q79	Q78	Q77	Q76	Q75	Q74

Addr	Register Name	D7	D6	D5	D4	D3	D2	D1	D0
20H	GPE	GPE	RXDETE	VINE	FAST	EXCKMD	DCNT	DTS16	DTS14
21H	GPDR	IO7	IO6	IO5	IO4	IO3	IO2	IO1	IO0
22H	GPSCR	CS7	SC6	CS5	SC4	SC3	SC2	SC1	CS0
23H	GPLR	GPL7	GPL 6	GPL 5	GPL 4	GPL 3	GPL 2	GPL 1	GPL 0
24H	DAT Mask & DTS Detect	XMCK	DIV	MED1	MDR0	MSTC1	MSTC0	MDAT1	MDAT0
25H	RX Detect	RXDE7	RXDE6	RXDE5	RXDE4	RXDE3	RXDE2	RXDE1	RXDE0
26H	STC & DAT Detect	0	0	0	0	0	0	STC	DAT
27H	RX Channel Status Byte 5	0	0	0	0	0	0	CR41	CR40
28H	TX Channel Status Byte 5	0	1	0	0	0	0	CT41	CT40

Note: When the PDN pin goes “L”, the registers are initialized to their default values.

When RSTN bit goes “0”, the internal timing is reset and the registers are initialized to their default values.

All data can be written to the register even if PWN bit is “0”.

■ Register Definitions

Reset & Initialize

Addr	Register Name	D7	D6	D5	D4	D3	D2	D1	D0
00H	CLK & Power Down Control	CS12	BCU	CM1	CM0	OCKS1	OCKS0	PWN	RSTN
	R/W	R/W	R/W	R/W	R/W	R/W	R/W	R/W	R/W
	Default	0	1	0	0	0	0	1	1

RSTN: Timing Reset & Register Initialize

0: Reset & Initialize

1: Normal Operation

PWN: Power Down

0: Power Down

1: Normal Operation

OCKS1-0: Master Clock Frequency Select

CM1-0: Master Clock Operation Mode Select

BCU: Block start & C/U Output Mode

When BCU=1, the three Output Pins(BOUT, COUT, UOUT) become to be enabled.

The block signal goes high at the start of frame 0 and remains high until the end of frame 31.

CS12: Channel Status Select

0: Channel 1

1: Channel 2

Selects which channel status is used to derive C-bit buffers, AUDION, PEM, FS3, FS2, FS1, FS0, Pc and Pd. The de-emphasis filter is controlled by channel 1 in the Parallel Mode.

Format & De-emphasis Control

Addr	Register Name	D7	D6	D5	D4	D3	D2	D1	D0
01H	Format & De-em Control	MONO	DIF2	DIF1	DIF0	DEAU	DEM1	DEM0	DFS
	R/W	R/W	R/W	R/W	R/W	R/W	R/W	R/W	R/W
	Default	0	1	1	0	1	0	1	0

DFS: 96kHz De-emphasis Control

DEM1-0: 32, 44.1, 48kHz De-emphasis Control ([Table 11](#))

DEAU: De-emphasis Auto Detect Enable

0: Disable

1: Enable

DIF2-0: Audio Data Format Control ([Table 17](#))

MONO: Double sampling frequency mode enable

0: Stereo mode

1: Mono mode

Input/Output Control

Addr	Register Name	D7	D6	D5	D4	D3	D2	D1	D0
02H	Input/ Output Control 0	TX1E	OPS12	OPS11	OPS10	TX0E	OPS02	OPS01	OPS00
	R/W	R/W	R/W	R/W	R/W	R/W	R/W	R/W	R/W
	Default	1	0	0	0	1	0	0	0

OPS02-00: Output Through Data Select for TX0 pin

OPS12-10: Output Through Data Select for TX1 pin

TX0E: TX0 Output Enable

0: Disable. TX0 outputs "L".

1: Enable

TX1E: TX1 Output Enable

0: Disable. TX1 outputs "L".

1: Enable

Addr	Register Name	D7	D6	D5	D4	D3	D2	D1	D0
03H	Input/ Output Control 1	EFH1	EFH0	UDIT	TLR	DIT	IPS2	IPS1	IPS0
	R/W	R/W	R/W	R/W	R/W	R/W	R/W	R/W	R/W
	Default	0	1	0	0	1	0	0	0

IPS2-0: Input Recovery Data Select

DIT: Through data/Transmit data select for TX1 pin

0: Through data (RX data).

1: Transmit data (DAUX data).

TLR: Double sampling frequency mode channel select for DIT(stereo)

0: L channel

1: R channel

UDIT: U bit control for DIT

0: U bit is fixed to "0"

1: Recovered U bit is used for DIT (loop mode for U bit)

EFH1-0: Interrupt 0 Pin Hold Count Select

00: 512 LRCK

01: 1024 LRCK

10: 2048 LRCK

11: 4096 LRCK

Mask Control for INT0

Addr	Register Name	D7	D6	D5	D4	D3	D2	D1	D0
04H	INT0 MASK	MQI0	MAT0	MCI0	MUL0	MDTS0	MPE0	MAN0	MPR0
	R/W	R/W	R/W	R/W	R/W	R/W	R/W	R/W	R/W
	Default	1	1	1	0	1	1	1	0

MPR0: Mask Enable for PAR bit
 MAN0: Mask Enable for AUDN bit
 MPE0: Mask Enable for PEM bit
 MDTS0: Mask Enable for DTSCD bit
 MUL0: Mask Enable for UNLOCK bit
 MCI0: Mask Enable for CINT bit
 MAT0: Mask Enable for AUTO bit
 MQI0: Mask Enable for QINT bit

0: Mask disable
 1: Mask enable

Mask Control for INT1

Addr	Register Name	D7	D6	D5	D4	D3	D2	D1	D0
05H	INT1 MASK	MQI1	MAT1	MCI1	MUL1	MDTS1	MPE1	MAN1	MPR1
	R/W	R/W	R/W	R/W	R/W	R/W	R/W	R/W	R/W
	Default	1	0	1	1	0	1	0	1

MPR1: Mask Enable for PAR bit
 MAN1: Mask Enable for AUDN bit
 MPE1: Mask Enable for PEM bit
 MDTS1: Mask Enable for DTSCD bit
 MUL1: Mask Enable for UNLOCK0 bit
 MCI1: Mask Enable for CINT bit
 MAT1: Mask Enable for AUTO bit
 MQI1: Mask Enable for QINT bit

0: Mask disable
 1: Mask enable

Receiver Status 0

Addr	Register Name	D7	D6	D5	D4	D3	D2	D1	D0
06H	Receiver status 0	QINT	AUTO	CINT	UNLCK	DTSCD	PEM	AUDION	PAR
	R/W	RD	RD	RD	RD	RD	RD	RD	RD
	Default	0	0	0	0	0	0	0	0

PAR: Parity Error or Biphas Error Status

0: No Error

1: Error

It is "1" if Parity Error or Biphas Error is detected in the sub-frame.

AUDION: Audio Bit Output

0: Audio

1: Non Audio

This bit is made by encoding channel status bits.

PEM: Pre-emphasis Detect.

0: OFF

1: ON

This bit is made by encoding channel status bits.

DTSCD: DTS-CD Auto Detect

0: No detect

1: Detect

UNLCK: PLL Lock Status

0: Locked

1: Unlocked

CINT: Channel Status Buffer Interrupt

0: No change

1: Changed

AUTO: Non-PCM Auto Detect

0: No detect

1: Detect

QINT: Q-subcode Buffer Interrupt

0: No change

1: Changed

QINT, CINT and PAR bits are initialized when 06H is read.

Receiver Status 1

Addr	Register Name	D7	D6	D5	D4	D3	D2	D1	D0
07H	Receiver status 1	FS3	FS2	FS1	FS0	0	V	QCRC	CCRC
	R/W	RD	RD	RD	RD	RD	RD	RD	RD
	Default	0	0	0	1	0	0	0	0

CCRC: Cyclic Redundancy Check for Channel Status

0: No Error

1: Error

QCRC: Cyclic Redundancy Check for Q-subcode

0: No Error

1: Error

V: Validity of channel status

0: Valid

1: Invalid

FS3-0: Sampling Frequency detection ([Table 7](#))

Receiver Channel Status

Addr	Register Name	D7	D6	D5	D4	D3	D2	D1	D0
08H	RX Channel Status Byte 0	CR7	CR6	CR5	CR4	CR3	CR2	CR1	CR0
09H	RX Channel Status Byte 1	CR15	CR14	CR13	CR12	CR11	CR10	CR9	CR8
0AH	RX Channel Status Byte 2	CR23	CR22	CR21	CR20	CR19	CR18	CR17	CR16
0BH	RX Channel Status Byte 3	CR31	CR30	CR29	CR28	CR27	CR26	CR25	CR24
0CH	RX Channel Status Byte 4	CR39	CR38	CR37	CR36	CR35	CR34	CR33	CR32
27H	RX Channel Status Byte 5	0	0	0	0	0	0	CR41	CR40
R/W		RD							
Default		Not initialized							

CR41-0: Receiver Channel Status Byte 5-0

Transmitter Channel Status

Addr	Register Name	D7	D6	D5	D4	D3	D2	D1	D0
0DH	TX Channel Status Byte 0	CT7	CT6	CT5	CT4	CT3	CT2	CT1	CT0
0EH	TX Channel Status Byte 1	CT15	CT14	CT13	CT12	CT11	CT10	CT9	CT8
0FH	TX Channel Status Byte 2	CT23	CT22	CT21	CT20	CT19	CT18	CT17	CT16
10H	TX Channel Status Byte 3	CT31	CT30	CT29	CT28	CT27	CT26	CT25	CT24
11H	TX Channel Status Byte 4	CT39	CT38	CT37	CT36	CT35	CT34	CT33	CT32
28H	TX Channel Status Byte 5	0	1	0	0	0	0	CT41	CT40
R/W		R/W							
Default		0							

CT41-0: Transmitter Channel Status Byte 5-0

Burst Preamble Pc/Pd in non-PCM encoded Audio Bitstreams

Addr	Register Name	D7	D6	D5	D4	D3	D2	D1	D0
12H	Burst Preamble Pc Byte 0	PC7	PC6	PC5	PC4	PC3	PC2	PC1	PC0
13H	Burst Preamble Pc Byte 1	PC15	PC14	PC13	PC12	PC11	PC10	PC9	PC8
14H	Burst Preamble Pd Byte 0	PD7	PD6	PD5	PD4	PD3	PD2	PD1	PD0
15H	Burst Preamble Pd Byte 1	PD15	PD14	PD13	PD12	PD11	PD10	PD9	PD8
R/W		RD							
Default		Not initialized							

PC15-0: Burst Preamble Pc Byte 0 and 1

PD15-0: Burst Preamble Pd Byte 0 and 1

Q-subcode Buffer

Addr	Register Name	D7	D6	D5	D4	D3	D2	D1	D0
16H	Q-subcode Address / Control	Q9	Q8	Q7	Q6	Q5	Q4	Q3	Q2
17H	Q-subcode Track	Q17	Q16	Q15	Q14	Q13	Q12	Q11	Q10
18H	Q-subcode Index	Q25	Q24	Q23	Q22	Q21	Q20	Q19	Q18
19H	Q-subcode Minute	Q33	Q32	Q31	Q30	Q29	Q28	Q27	Q26
1AH	Q-subcode Second	Q41	Q40	Q39	Q38	Q37	Q36	Q35	Q34
1BH	Q-subcode Frame	Q49	Q48	Q47	Q46	Q45	Q44	Q43	Q42
1CH	Q-subcode Zero	Q57	Q56	Q55	Q54	Q53	Q52	Q51	Q50
1DH	Q-subcode ABS Minute	Q65	Q64	Q63	Q62	Q61	Q60	Q59	Q58
1EH	Q-subcode ABS Second	Q73	Q72	Q71	Q70	Q69	Q68	Q67	Q66
1FH	Q-subcode ABS Frame	Q81	Q80	Q79	Q78	Q77	Q76	Q75	Q74
R/W		RD							
Default		Not initialized							

GPIO Control

Addr	Register Name	D7	D6	D5	D4	D3	D2	D1	D0
20H	GPE	GPE	RXDETE	VINE	FAST	EXCKMD	DCNT	DTS16	DTS14
R/W		R/W	R/W	R/W	R/W	R/W	R/W	R/W	R/W
Default		0	1	1	1	0	1	1	1

DTS14: DTS-CD 14bit Sync Word Detect

0: Disable

1: Enable (default)

DTS16: DTS-CD 16bit Sync Word Detect

0: Disable

1: Enable (default)

DCNT: Start ID Counter

0: Disable

1: Enable (default)

EXCKMD: X'tal Oscillator Setting

0: Power Up (default)

1: Power Down

FAST: PLL Lock Time Select ([Table 1](#))

0: $\leq (15\text{ms} + 384/\text{fs})$ (default)

1: $\leq (15\text{ms} + 1/\text{fs})$

VINE: VIN Input Enable

0: Disable

1: Enable (default)

RXDETE: RX Input Detect Enable

0: Disable

1: Enable (default)

GPE: GPIO mode Enable

0: GPIO mode Disable (default)

1: GPIO mode Enable

GPIO mode for GP2-7 pins is enabled when GPE bit= "1" and BCU bit= TX1E bit= TX0E bit= "0". The GP0 pin is in GPIO mode regardless of the state of GPE bit when VINE bit= "0". The GP1 pin is always in GPIO mode.

Addr	Register Name	D7	D6	D5	D4	D3	D2	D1	D0
21H	GPDR	IO7	IO6	IO5	IO4	IO3	IO2	IO1	IO0
	R/W	R/W	R/W	R/W	R/W	R/W	R/W	R/W	R/W
	Default	0	0	0	0	0	0	0	0

IO7-0: GPIO pin Input/Output Setting

0: Input (default)

1: Output

Addr	Register Name	D7	D6	D5	D4	D3	D2	D1	D0
22H	GPSCR	SC7	SC6	SC5	SC4	SC3	SC2	SC1	SC0
	R/W	R/W	R/W	R/W	R/W	R/W	R/W	R/W	R/W
	Default	0	0	0	0	0	0	0	0

SC7-0: GPIO pin Output Level Setting

0: "L" (default)

1: "H"

This is effective only when the pin setting is in output mode (21H: GPDR= "1"). Actual pin level can be read by GPLR register.

Addr	Register Name	D7	D6	D5	D4	D3	D2	D1	D0
23H	GPLR	GPL7	GPL6	GPL5	GPL4	GPL3	GPL2	GPL1	GPL0
	R/W	RD	RD	RD	RD	RD	RD	RD	RD
	Default	0	0	0	0	0	0	0	0

GPD7-0: GPIO pin Input Level Read

GPL7-0 bits are read only register that can read the input signal level of corresponding GPIO pins (GP7-0 pins). GPIO mode is enabled GP2-7 pins can read the input signal level when GPE bit = "1" and BCU bit = TX1E bit = TX0E bit = "0". When VINE bit = "0", GPIO mode of the GP1 pin is enabled and GPL0 bit can read the input signal level. GPL1 bit can always read the input signal level of the GP1 pin. GPL2-7 bits and GPL0 bit are always "0" when GPIO mode is disable.

DAT Mask & DTS Detect

Addr	Register Name	D7	D6	D5	D4	D3	D2	D1	D0
24H	DAT Mask & DTS Detect	XMCK	DIV	MRDT1	MRDT0	MSTC1	MSTC0	MDAT1	MDAT0
	R/W	R/W	R/W	R/W	R/W	R/W	R/W	R/W	R/W
	Default	0	0	1	1	1	1	1	1

MDAT0: Mask enable for DAT bit

0: Mask disable

1: Mask enable (default)

When the Mask is enabled “1”, DAT state is not reflected on to the INT0 pin.

MDAT1: Mask enable for DAT bit

0: Mask disable

1: Mask enable (default)

When the Mask is enabled “1”, DAT state is not reflected on to the INT1 pin.

MSTC0: Mask enable for STC bit

0: Disable

1: Enable (default)

When the Mask is enabled “1”, STC state is not reflected on to the INT0 pin.

MSTC1: Mask enable for STC bit

0: Disable

1: Enable (default)

When the Mask is enabled “1”, STC state is not reflected on to the INT1 pin.

MRDT0: Mask enable for RX Detect

0: Disable

1: Enable (default)

When the Mask is enabled “1”, RX input detection result is not reflected on to the INT0 pin.

MRDT1: Mask enable for RX Detect

0: Disable

1: Enable (default)

When the Mask is enabled “1”, RX input detection result is not reflected on to the INT1 pin.

DIV: MCKO2 Frequency Dividing Ratio in X'tal mode ([Table 4](#))

0: x1 (default)

1: x 1/2

XMCK: MCKO2 Output Setting ([Table 4](#))

0: Setting by CM1-0 bits and OCKS1-0 bits (default)

1: Fixed in X'tal mode

RX Detect

Addr	Register Name	D7	D6	D5	D4	D3	D2	D1	D0
25H	RX Detect	RXDE7	RXDE6	RXDE5	RXDE4	RXDE3	RXDE2	RXDE1	RXDE0
	R/W	RD	RD	RD	RD	RD	RD	RD	RD
	Default	0	0	0	0	0	0	0	0

RXDE7-0: The RX pin Input Detect

0: No Detect

1: Detect

When the RXDETE bit is set to “0”, the input detection function is disabled and the register is fixed to “0”. When the unused RX pin is open, the AK4118A may not be able to detect the input signal correctly. The unused RX pin should be connected to the GND.

STC & DAT Detect

Addr	Register Name	D7	D6	D5	D4	D3	D2	D1	D0
26H	STC & DAT Detect	0	0	0	0	0	0	STC	DAT
	R/W	RD	RD	RD	RD	RD	RD	RD	RD
	Default	0	0	0	0	0	0	0	0

DAT: DAT Start ID Detect

0: No detect

1: Detect

DAT bit is initialized when Addr= 26H is READ.

STC: Change Detection of Sampling Frequency and pre-emphasis information

0: No detect

1: Detect

When FS3-0 bits or PEM bit is changed, STC bit goes to “1”. STC bit is initialized when Addr=26H is READ.

■ Burst Preambles in non-PCM Bitstreams

Figure 44. Data structure in IEC60958

Preamble word	Length of field	Contents	Value
Pa	16 bits	sync word 1	0xF872
Pb	16 bits	sync word 2	0x4E1F
Pc	16 bits	Burst info	see Table 23
Pd	16 bits	Length code	numbers of bits

Table 22. Burst preamble words

Bits of Pc	Value	Contents	Repetition time of burst in IEC60958 frames
0-4	0	data type NULL data	≤4096
	1	Dolby AC-3 data	1536
	2	reserved	
	3	PAUSE	
	4	MPEG-1 Layer1 data	384
	5	MPEG-1 Layer2 or 3 data or MPEG-2 without extension	1152
	6	MPEG-2 data with extension	1152
	7	MPEG-2 AAC ADTS	1024
	8	MPEG-2, Layer1 Low sample rate	384
	9	MPEG-2, Layer2 or 3 Low sample rate	1152
	10	reserved	
	11	DTS type I	512
	12	DTS type II	1024
	13	DTS type III	2048
	14	ATRAC	512
	15	ATRAC2/3	1024
16-31	reserved		
5, 6	0	reserved, shall be set to "0"	
7	0	error-flag indicating a valid burst_payload	
	1	error-flag indicating that the burst_payload may contain errors	
8-12		data type dependent info	
13-15	0	bit stream number, shall be set to "0"	

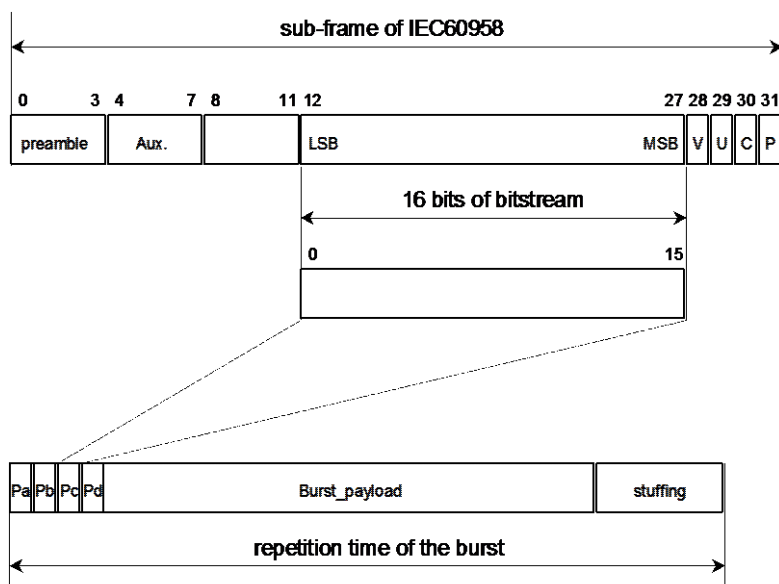
Table 23. Fields of burst info Pc

■ Non-PCM Bitstream Timing

1) When Non-PCM preamble data is not coming within 4096 frames,

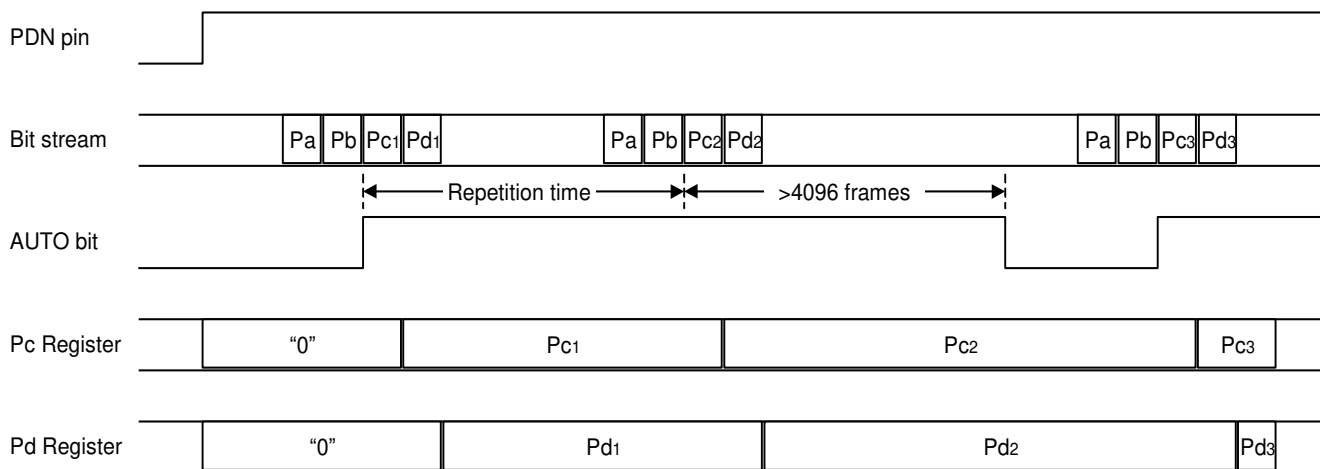

Figure 45. Timing Example 1

2) When Non-PCM bitstream stops (when MULK0 bit = "0"),

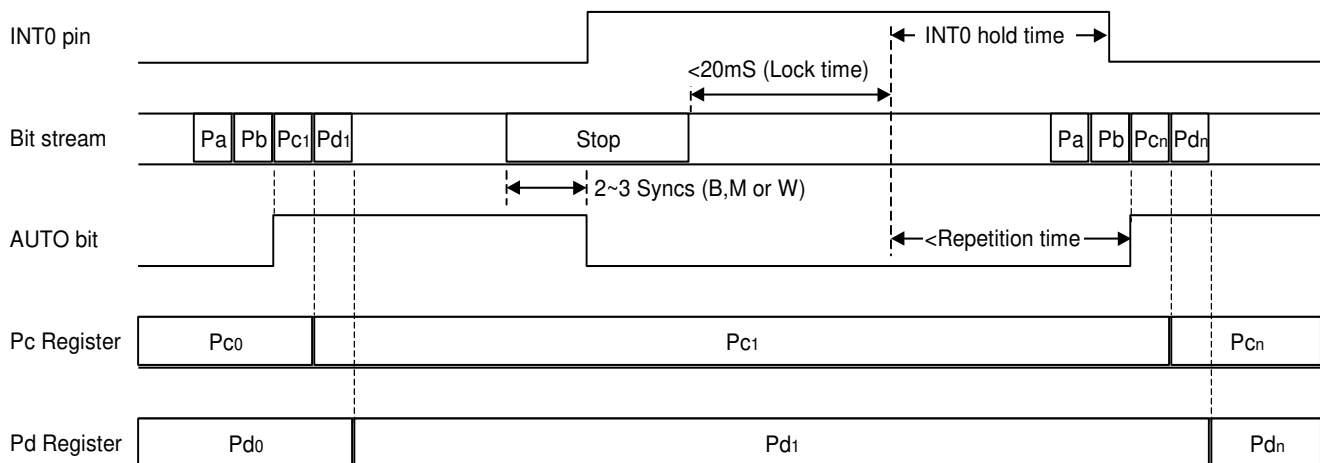

Figure 46. Timing Example 2

SYSTEM DESIGN

Figure 47 shows the example of system connection diagram for Serial Mode.

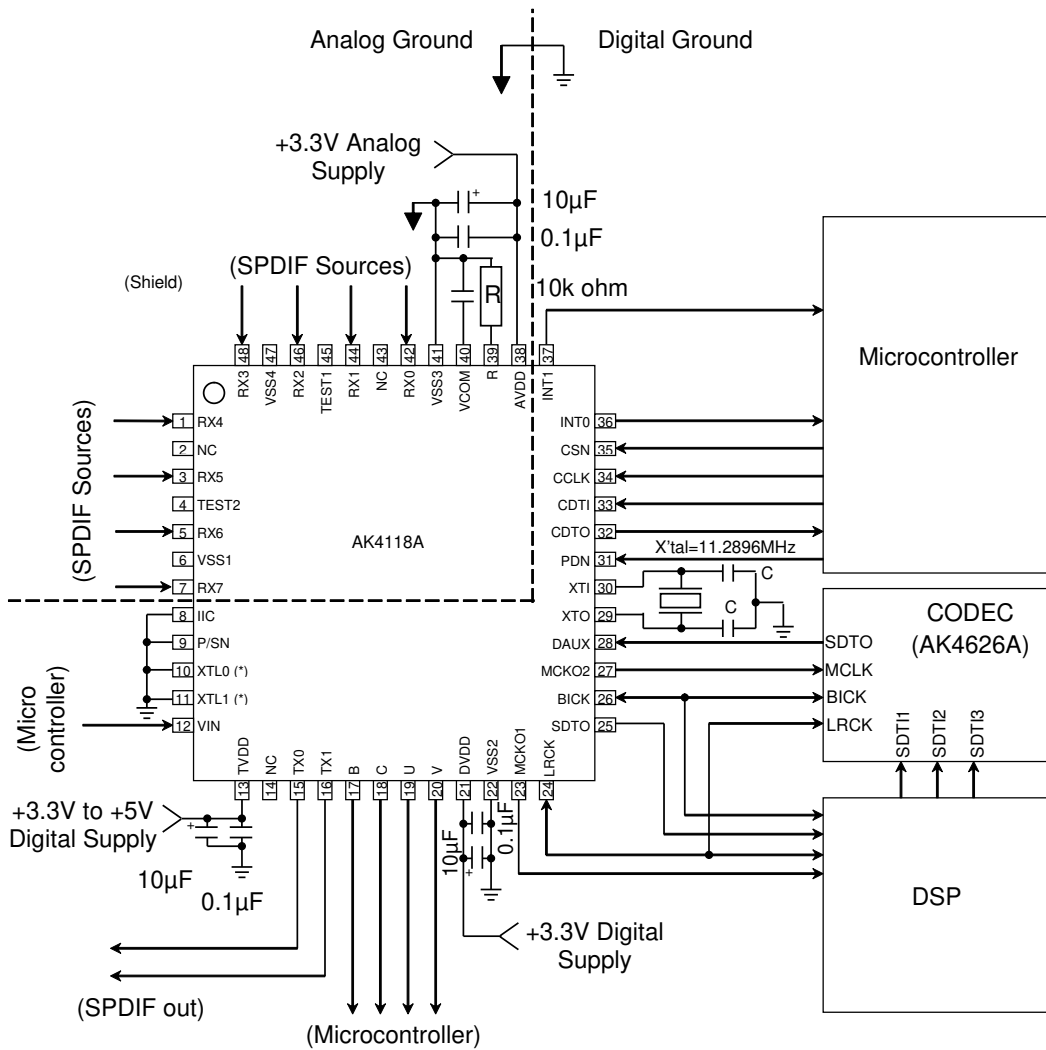

Figure 47. Typical Connection Diagram (Serial Mode)

Notes

- For XTLO and XTL1 settings, refer to the [Table 5](#).
- “C” value is dependent on the crystal.
- VSS1-4 must be connected the same ground plane.
- Digital signals, especially clocks, should be kept away from the R pin in order to avoid an effect to the clock jitter performance.

PACKAGE

48pin LQFP(Unit:mm)

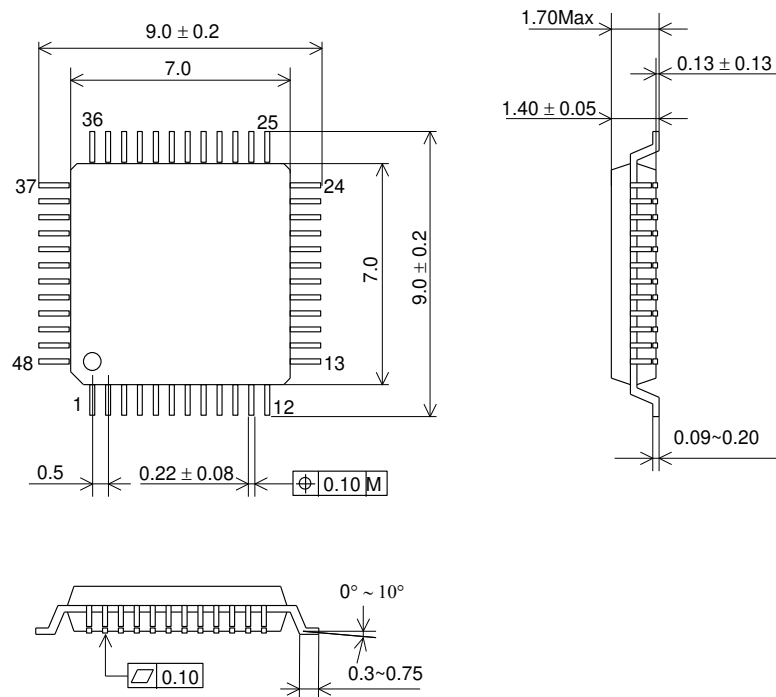

Material & Lead finish

Package molding compound: Epoxy, Halogen (bromine and chlorine) free
 Lead frame material: Cu
 Lead frame surface treatment: Solder (Pb free) plate

MARKING

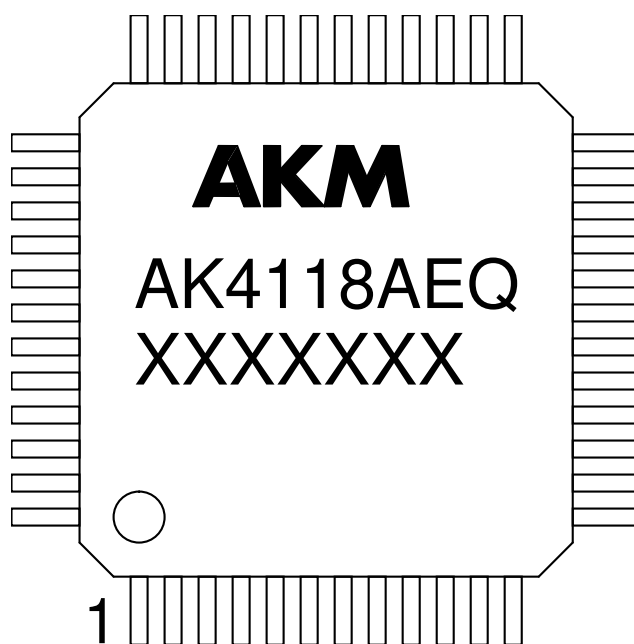

XXXXXXXX: Date code identifier

REVISION HISTORY

Date (Y/M/D)	Revision	Reason	Page	Contents
09/10/06	00	First Edition		
09/10/21	01	Error Correction	39	■ Register Map Addr 11H, D6~D1: CT39 → CT38 ~ 33
			45	Transmitter Channel Status Addr 28H, D0: CT42 → CT40
09/12/24	02	Description Addition	4	“■ Compatibility with AK4118” was added.
			16	A description about Table 3 was added.
13/09/19	03	Error Correction	34	■ GPIO Controller Table 37~40 → Table 18 ~ Table 21

IMPORTANT NOTICE

0. Asahi Kasei Microdevices Corporation (“AKM”) reserves the right to make changes to the information contained in this document without notice. When you consider any use or application of AKM product stipulated in this document (“Product”), please make inquiries the sales office of AKM or authorized distributors as to current status of the Products.
1. All information included in this document are provided only to illustrate the operation and application examples of AKM Products. AKM neither makes warranties or representations with respect to the accuracy or completeness of the information contained in this document nor grants any license to any intellectual property rights or any other rights of AKM or any third party with respect to the information in this document. You are fully responsible for use of such information contained in this document in your product design or applications. **AKM ASSUMES NO LIABILITY FOR ANY LOSSES INCURRED BY YOU OR THIRD PARTIES ARISING FROM THE USE OF SUCH INFORMATION IN YOUR PRODUCT DESIGN OR APPLICATIONS.**
2. The Product is neither intended nor warranted for use in equipment or systems that require extraordinarily high levels of quality and/or reliability and/or a malfunction or failure of which may cause loss of human life, bodily injury, serious property damage or serious public impact, including but not limited to, equipment used in nuclear facilities, equipment used in the aerospace industry, medical equipment, equipment used for automobiles, trains, ships and other transportation, traffic signaling equipment, equipment used to control combustions or explosions, safety devices, elevators and escalators, devices related to electric power, and equipment used in finance-related fields. Do not use Product for the above use unless specifically agreed by AKM in writing.
3. Though AKM works continually to improve the Product’s quality and reliability, you are responsible for complying with safety standards and for providing adequate designs and safeguards for your hardware, software and systems which minimize risk and avoid situations in which a malfunction or failure of the Product could cause loss of human life, bodily injury or damage to property, including data loss or corruption.
4. Do not use or otherwise make available the Product or related technology or any information contained in this document for any military purposes, including without limitation, for the design, development, use, stockpiling or manufacturing of nuclear, chemical, or biological weapons or missile technology products (mass destruction weapons). When exporting the Products or related technology or any information contained in this document, you should comply with the applicable export control laws and regulations and follow the procedures required by such laws and regulations. The Products and related technology may not be used for or incorporated into any products or systems whose manufacture, use, or sale is prohibited under any applicable domestic or foreign laws or regulations.
5. Please contact AKM sales representative for details as to environmental matters such as the RoHS compatibility of the Product. Please use the Product in compliance with all applicable laws and regulations that regulate the inclusion or use of controlled substances, including without limitation, the EU RoHS Directive. AKM assumes no liability for damages or losses occurring as a result of noncompliance with applicable laws and regulations.
6. Resale of the Product with provisions different from the statement and/or technical features set forth in this document shall immediately void any warranty granted by AKM for the Product and shall not create or extend in any manner whatsoever, any liability of AKM.
7. This document may not be reproduced or duplicated, in any form, in whole or in part, without prior written consent of AKM.