

DESCRIPTION

The TBMA is a test board for the MagAlpha magnetic position sensor family. The TBMA allows users to run and test MagAlpha sensors quickly. TBMA boards come in two different formats: round (RD) and long (LT). In the RD format, the sensor is mounted in an end-of-shaft configuration. In the LT format, the sensor is mounted on the edge of the board and can be used in both side-shaft and end-of-shaft configurations.

TBMA test boards are compatible with the MACOM evaluation kit, offering seamless connection and operation of MagAlpha sensors, and allowing users to evaluate MagAlpha functionalities and performances with their own set-up.

The TBMA test board only includes the assembled board with the sensor and decoupling capacitors. It does not include connectors.

FEATURES

- Round Board Format for End-of-Shaft Mounting
- Long Board Format for Side Shaft and End-of-Shaft Mounting
- Compatible with the MagAlpha Communication Interface Kit (EVKT-MACOM)

APPLICATIONS

- Servo Drives
- Robotics
- Automotive
- BLDC Motor Commutation
- Encoders

All MPS parts are lead-free, halogen-free, and adhere to the RoHS directive. For MPS green status, please visit the MPS website under Quality Assurance. "MPS", the MPS logo, and "Simple, Easy Solutions" are registered trademarks of Monolithic Power Systems, Inc. or its subsidiaries.

OVERVIEW

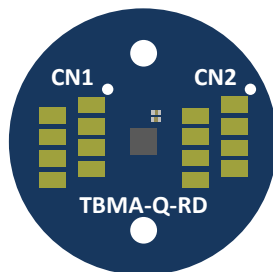

Round (RD) Format



Long (LT) Format

Figure 1: TBMA Test Boards

Board Types

Different board types are available, and each has a different schematic and layout design (see Table 1 on page 3). The board type to use is determined by the selected sensor part number.

Each board type is also available in two different formats: a round test board (RD), or a long test board (LT). The board part number specifies which format is used:

- TBMAXXX-Q-**RD**-XXX = Round test board
- TBMAXXX-Q-**LT**-XXX = Long test board

Both RD and LT board formats can be used for end-of-shaft configurations where the sensor is positioned at the end of the motor or knob shaft. For side-shaft configurations where the sensor is positioned perpendicularly to the motor or knob shaft, only the RD board format can be used.

Table 1: Board Type

Board Type	Board Part Number	MPS Chip Part Number
Board type 1	TBMA100-Q-RD	MA100
	TBMA100-Q-LT	
	TBMA300-Q-RD	MA300
	TBMA300-Q-LT	
	TBMA700-Q-RD	MA700
	TBMA700-Q-LT	
	TBMA750-Q-RD	MA750
	TBMA750-Q-LT	
Board type 2	TBMA102-Q-RD	MA102
	TBMA102-Q-LT	
	TBMA302-Q-RD	MA302
	TBMA302-Q-LT	
	TBMA310-Q-RD	MA310
	TBMA310-Q-LT	
	TBMA702-Q-RD	MA702
	TBMA702-Q-LT	
	TBMA710-Q-RD	MA710
	TBMA710-Q-LT	
	TBMA730-Q-RD	MA730
	TBMA730-Q-LT	
	TBMA800-Q-RD	MA800
	TBMA800-Q-LT	
	TBMA820-Q-RD	MA820
	TBMA820-Q-LT	
	TBMA850-Q-RD	MA850
	TBMA850-Q-LT	
	TBMA704-Q-RD	MA704
	TBMA704-Q-LT	
	TBMA330-Q-RD	MA330
	TBMA330-Q-LT	
	TBMA732-Q-RD	MA732
	TBMA732-Q-LT	
	TBMAQ430-Q-RD	MAQ430
	TBMAQ430-Q-LT	
	TBMAQ470-Q-RD	MAQ470
	TBMAQ470-Q-LT	
	TBMAQ473-Q-RD	MAQ473
	TBMAQ473-Q-LT	

Board type 3	TBMA780-Q-RD	MA780
	TBMA780-Q-LT	
Board type 4	TBMA782-Q-RD	MA782
	TBMA782-Q-LT	
Board type 5	TBMA734-Q-RD	MA734
	TBMA734-Q-LT	

TBMA Contents

Figure 2 **Error! Reference source not found.** shows the TBMA test board contents, with each element described in the list below.

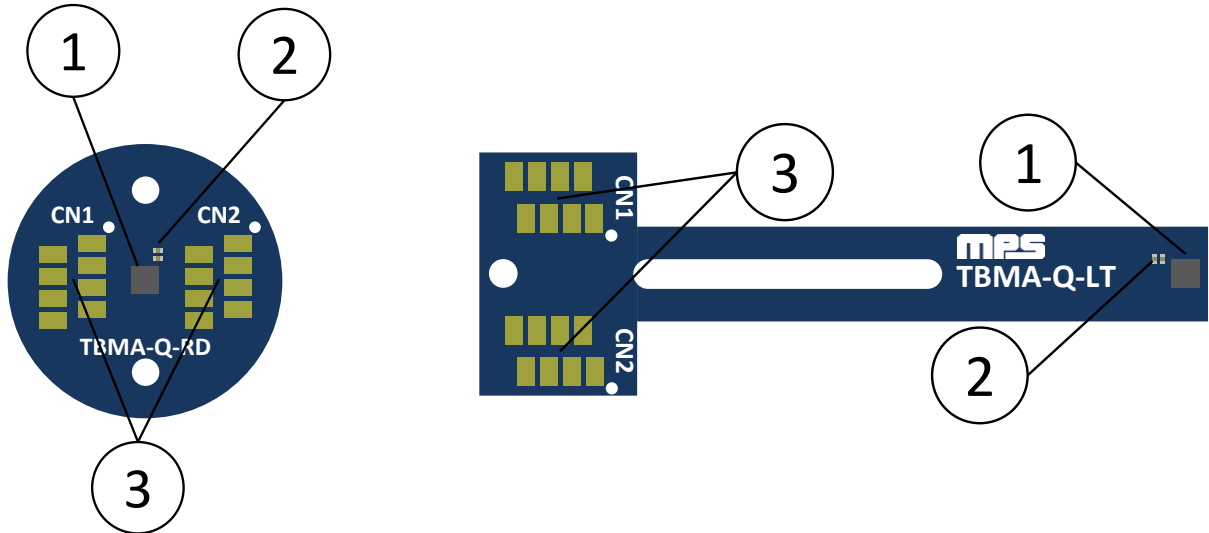

Figure 2: TBMA Contents

1. One TBMA board with MagAlpha mounted (RD or LT).
2. Decoupling capacitors.
3. Connector footprints (connectors not included).

BOARD TYPE 1

RD Format Overview

Figure 3 shows an overview of the Type 1 round (RD) board.

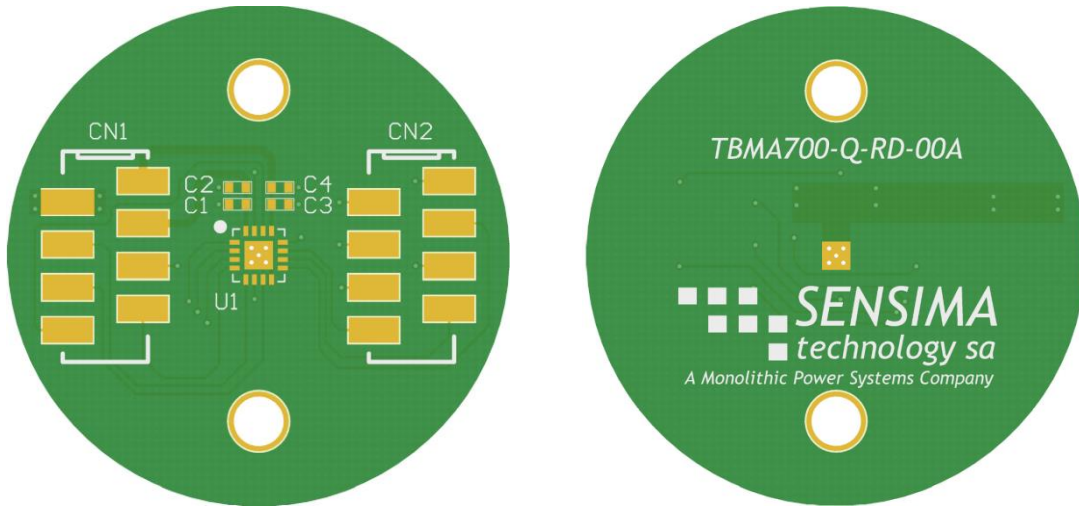

Figure 3: RD Type 1 Board Overview

LT Format Overview

Figure 4 shows an overview of the Type 1 long (LT) board.

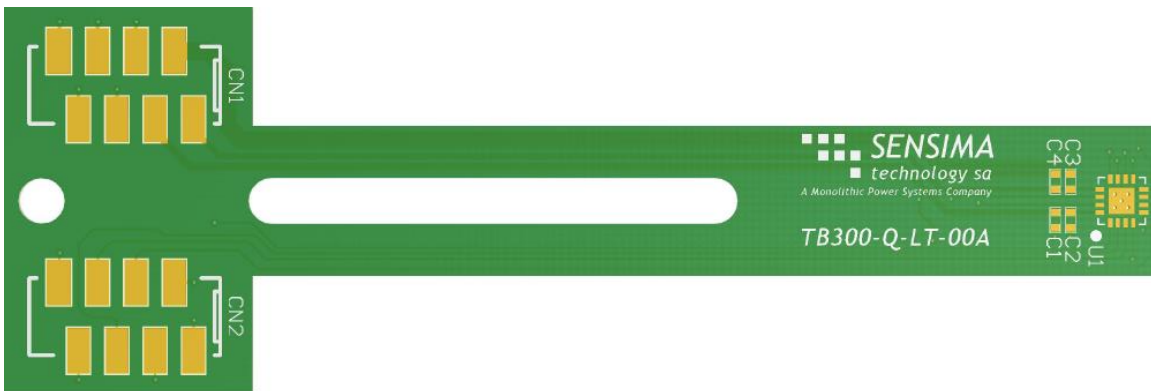

Figure 4: LT Type 1 Board Overview

Schematic

Figure 5 shows a schematic for the Type 1 boards.

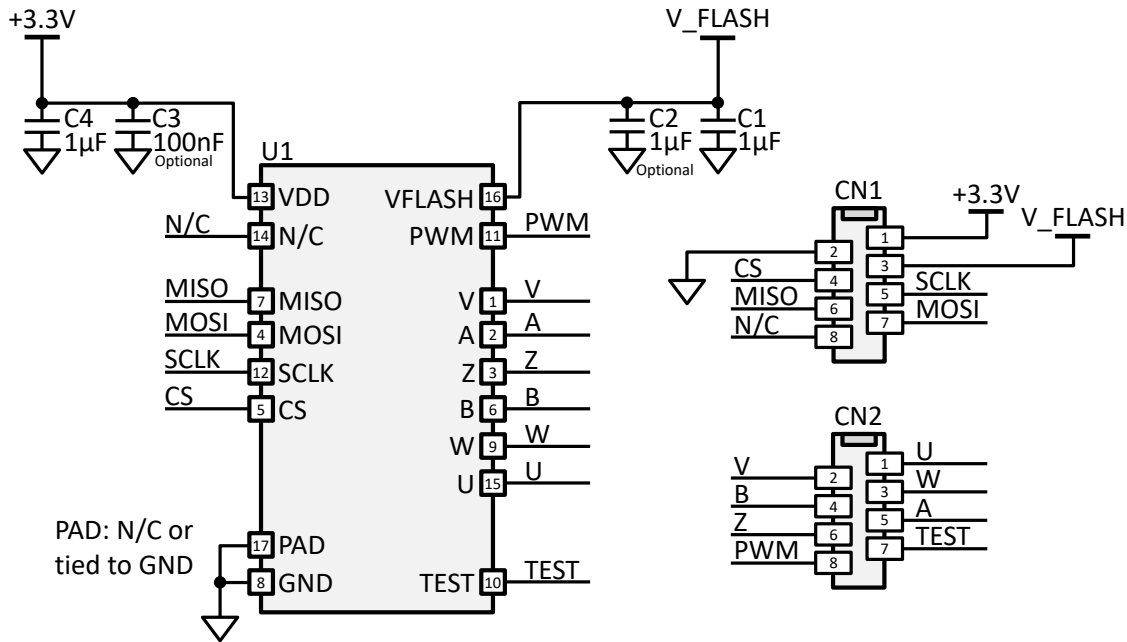

Figure 5: RD/LT Type 1 Schematic

Bill of Materials

Table 2 shows the Type 1 board bill of materials (BOM).

Table 2: Type 1 Board Bill of Materials

Quantity	Designator	Description	Value	Manufacturer	Manufacturer PN
2	C1, C4	Ceramic capacitor, 10V, X6S, 0402	1µF	Murata	GRM155C81A105KA12D
1	C2 (optional)	Ceramic capacitor, 10V, X6S, 0402	1µF	Murata	GRM155C81A105KA12D
1	C3 (optional)	Ceramic capacitor, 16V, X7R, 0402	100nF	Murata	GRM155R71C104KA88J
1	U1	MagAlpha magnetic position sensor	MAxxx	MPS	N/A
2	CN1, CN2 (not populated)	8-position receptacle connector, 0.100" (2.54mm), surface-mount tin		Würth or TE Connectivity	690367280876 or 7-2178711-8

Assembly View

Figure 6 shows the top-side assembly view of the Type 1 round board. Figure 7 shows the top-side assembly view of the Type 1 long board.

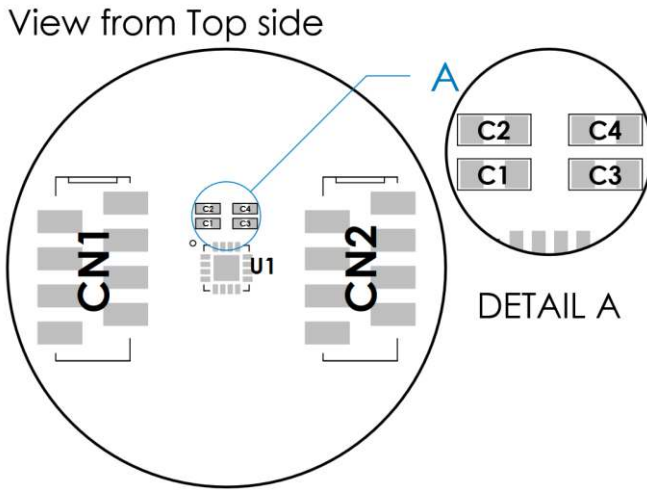

Figure 6: RD Type 1 Assembly View

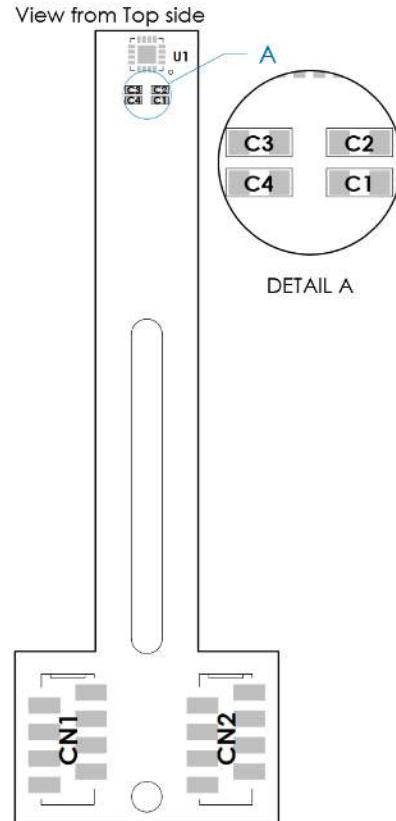

Figure 7: LT Type 1 Assembly View

Mechanical Drawing

Figure 8 shows the top-side mechanical drawing of the Type 1 round board. Figure 9 shows the top-side mechanical drawing of the Type 1 long board.

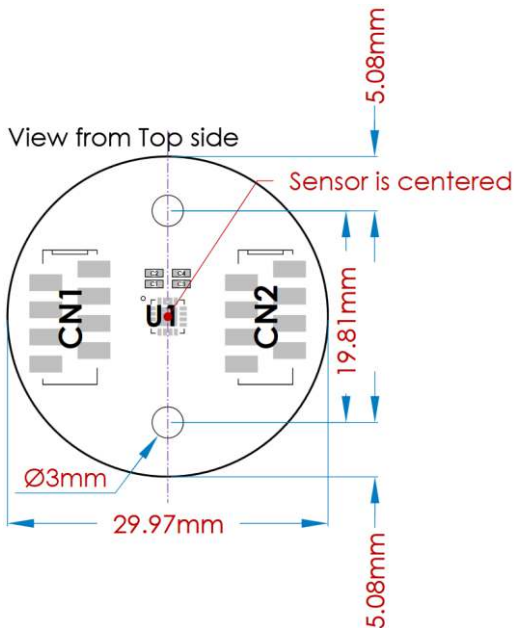
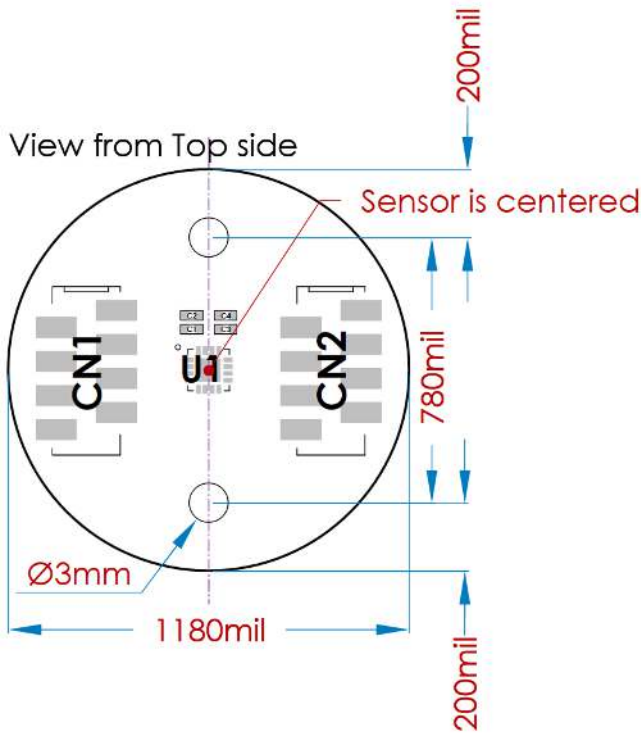

Figure 8: RD Type 1 Mechanical Drawing

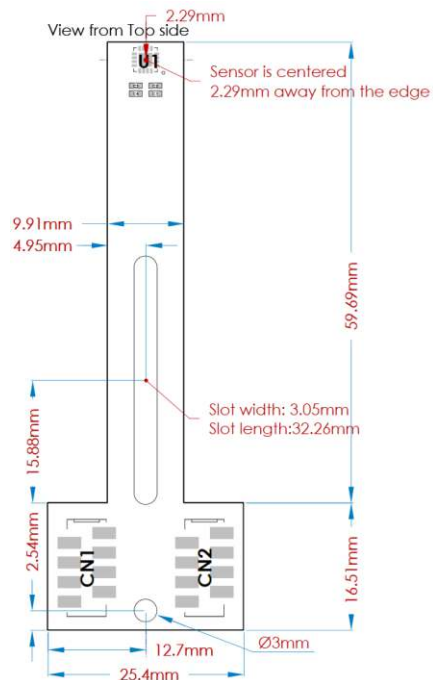
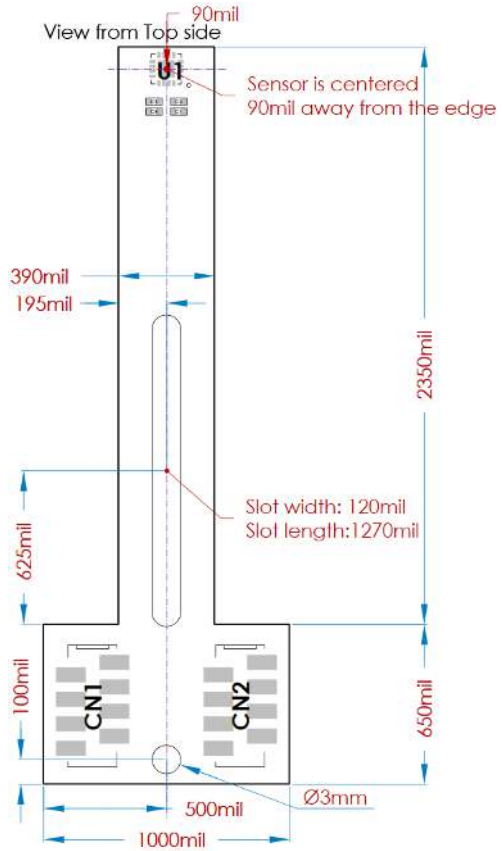

Figure 9: LT Type 1 Mechanical Drawing, mil = 0.001" = 0.0254mm

Connector Pinout

Figure 10 shows the Type 1 round board connector pinout. Figure 11 shows the Type 1 long board connector pinout.

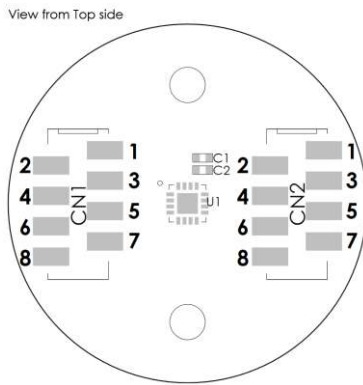

Figure 10: RD Type 1 Connector Pinout

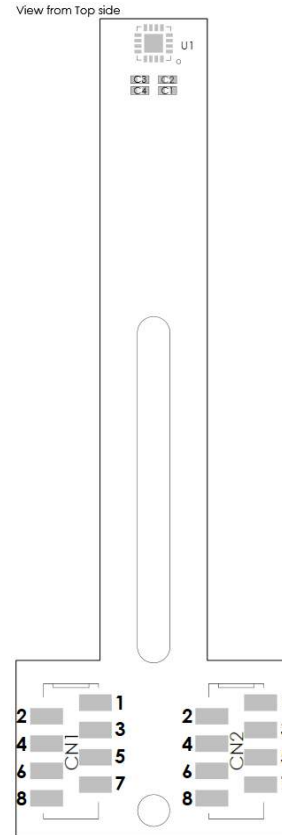

Figure 11: LT Type 1 Connector Pinout

Table 3 shows the Type 1 pin registers.

Table 3: Type 1 Board Connector Pin Registers

Pin	Name	Description
CN1.1	VDD	3.3V supply.
CN1.2	GND	Ground.
CN1.3	VFLASH	Flash power supply (3.9V only powered during flashing).
CN1.4	CS	Chip select (serial).
CN1.5	SCLK	Clock (serial).
CN1.6	MISO	Master in slave out (serial).
CN1.7	MOSI	Master out slave in (serial).
CN1.8	-	Leave unconnected.
CN2.1	U ⁽¹⁾	U output (optional motor commutation).
CN2.2	V ⁽¹⁾	V output (optional motor commutation).
CN2.3	W ⁽¹⁾	W output (optional motor commutation).
CN2.4	A ⁽¹⁾	A output (optional incremental encoder).
CN2.5	B ⁽¹⁾	B output (optional incremental encoder).
CN2.6	Z ⁽¹⁾	Z output (optional incremental encoder).
CN2.7	TEST	Test pin.
CN2.8	PWM ⁽¹⁾	Pulse-width modulation output (optional).

Note:

- 1) Availability of this option depends of the MagAlpha part number. Please refer directly to the part datasheet.

BOARD TYPE 2

RD Format Overview

Figure 12 shows an overview of the Type 2 round (RD) board.

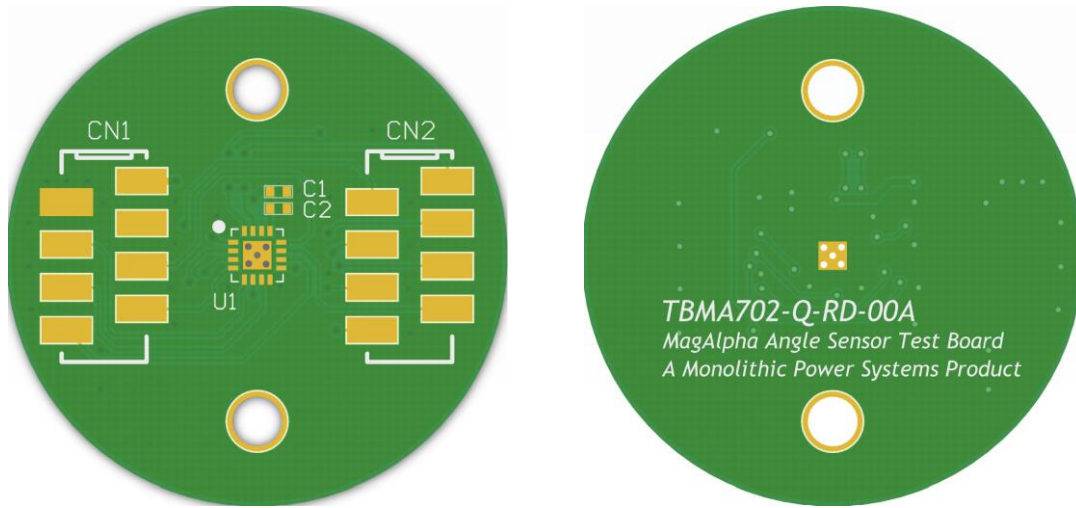

Figure 12: RD Type 2 Board Overview

LT Format Overview

Figure 13 shows an overview of the Type 2 long (LT) board.



Figure 13: LT Type 2 Board Overview

Schematic

Figure 14 shows a schematic for the Type 2 boards.

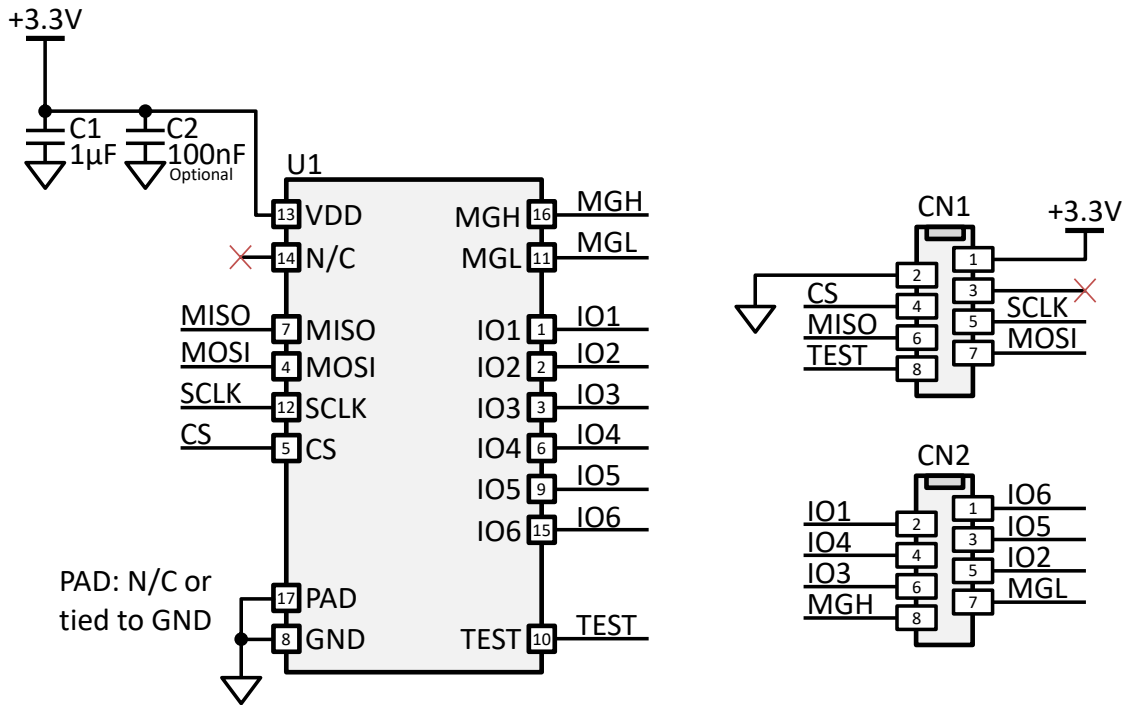

Figure 14: RD/LT Type 2 Schematic

Bill of Materials

Table 4 shows the Type 2 board bill of materials (BOM).

Table 4: Type 2 Board Bill of Materials

Quantity	Designator	Description	Value	Manufacturer	Manufacturer P/N
1	C1	Ceramic capacitor, 10V, X6S, 0402	1µF	Murata	GRM155C81A105KA12D
1	C2 (not populated)	Ceramic capacitor, 16V, X7R, 0402	100nF	Murata	GRM155R71C104KA88J
1	U1	MagAlpha magnetic position sensor	MAxxx	MPS	N/A
2	CN1, CN2 (not populated)	8-position receptacle connector, 0.100" (2.54mm), surface-mount tin		Würth or TE Connectivity	690367280876 or 7-2178711-8

Assembly View

Figure 15 shows the top-side assembly view of the Type 2 round board. Figure 16 shows the top-side assembly view of the Type 2 long board.

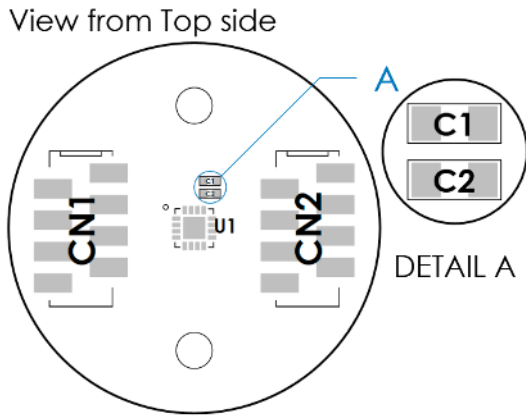

Figure 15: RD Type 2 Assembly View

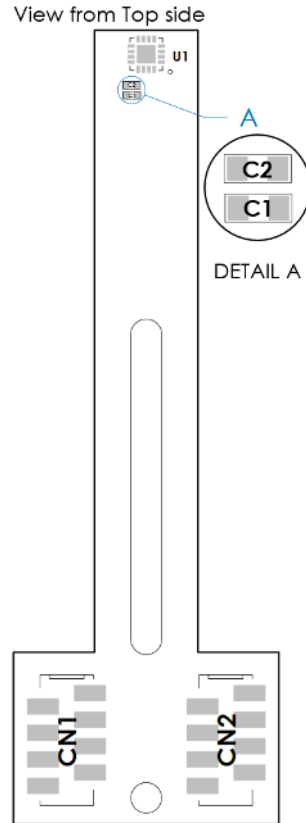

Figure 16: LT Type 2 Assembly View

Mechanical Drawing

Figure 17 shows the top-side mechanical drawing of the Type 2 round board. Figure 18 shows the top-side mechanical drawing of the Type 2 long board.

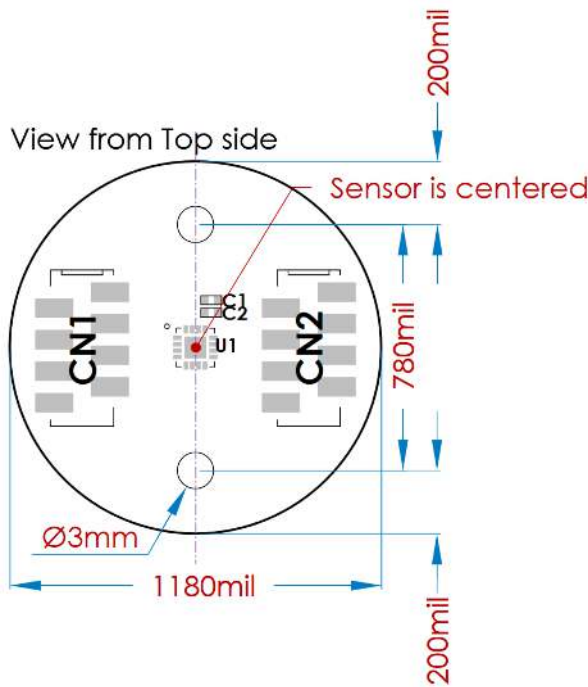

Figure 17: RD Type 2 Mechanical Drawing

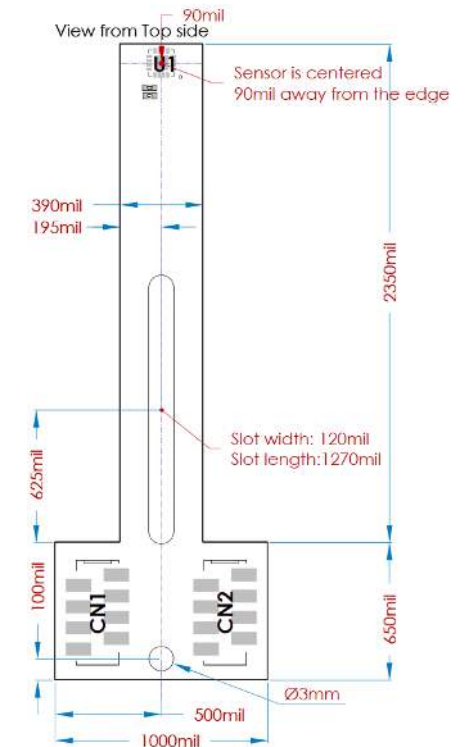
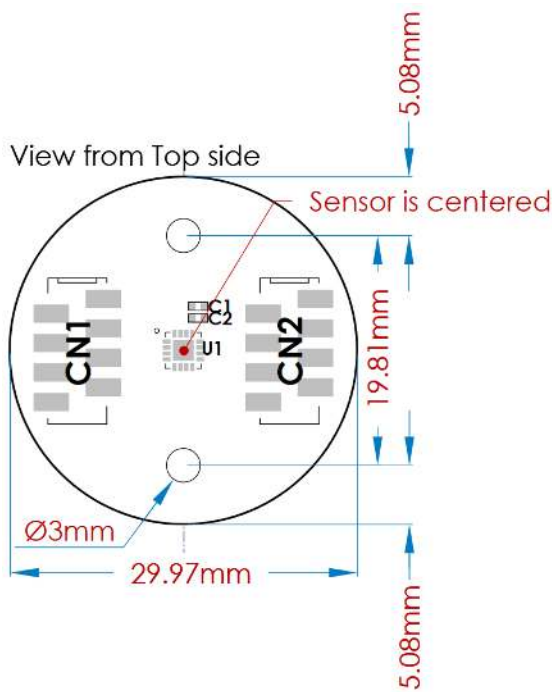
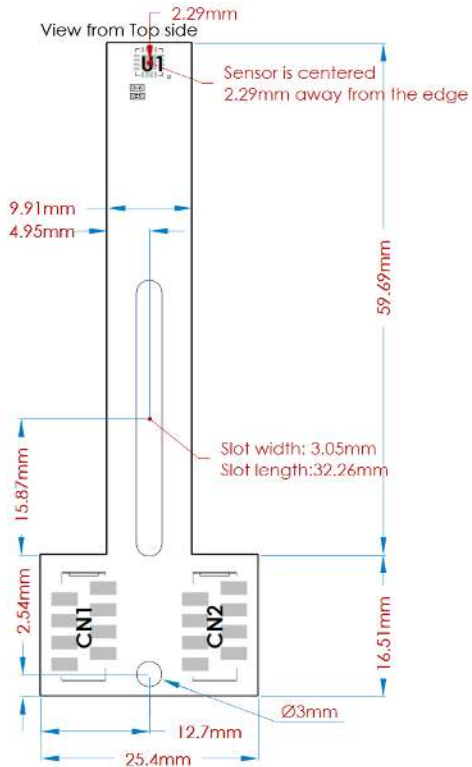

Figure 18: LT Type 2 Mechanical Drawing, mil = 0.001" = 0.0254mm



Connector Pinout

Figure 19 shows the Type 2 round board connector pinout. Figure 20 shows the Type 2 long board connector pinout.

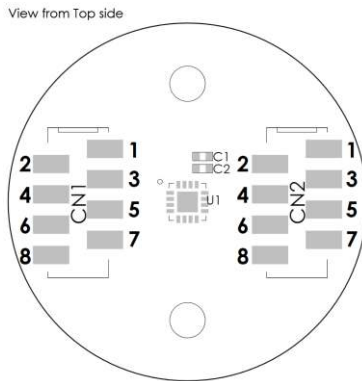

Figure 19: RD Type 2 Connector Pinout

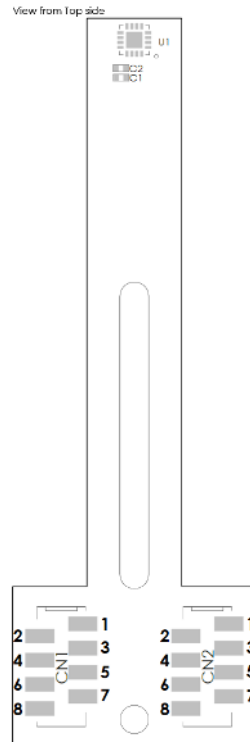

Figure 20: LT Type 2 Connector Pinout

Table 5 shows the Type 2 pin registers.

Table 5: Type 2 Board Connector Pin Registers

Pin	Name	Description
CN1.1	VDD	3.3V supply.
CN1.2	GND	Ground.
CN1.3	-	-
CN1.4	CS	Chip select (serial).
CN1.5	SCLK	Clock (serial).
CN1.6	MISO	Master in slave out (serial).
CN1.7	MOSI	Master out slave in (serial).
CN1.8	TEST	Test pin.
CN2.1	IO6 ⁽²⁾	Pin 15 (IO).
CN2.2	IO1 ⁽²⁾	Pin 1 (IO).
CN2.3	IO5 ⁽²⁾	Pin 9 (IO).
CN2.4	IO4 ⁽²⁾	Pin 6 (IO).
CN2.5	IO2 ⁽²⁾	Pin 2 (IO).
CN2.6	IO3 ⁽²⁾	Pin 3 (IO).
CN2.7	MGL ⁽³⁾	Magnetic level low (optional).
CN2.8	MGH ⁽³⁾	Magnetic level high (optional).

Notes:

- 2) Refer to the MagAlpha part datasheet to know which features are available on these pins.
- 3) Availability of this option depends of the MagAlpha part number. Please refer directly to the part datasheet.

BOARD TYPE 3

RD Format Overview

Figure 21 shows an overview of the Type 3 round (RD) board.

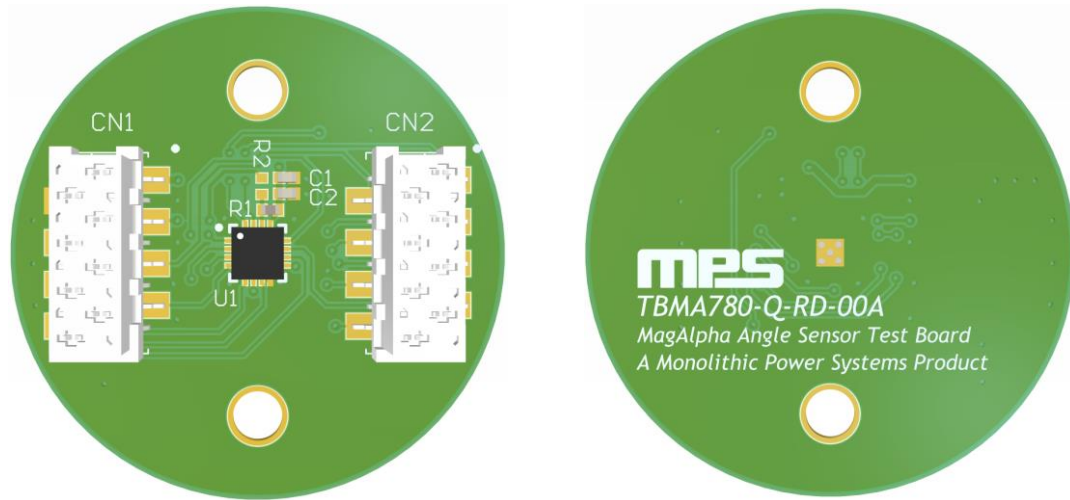

Figure 21: RD Type 3 Board Overview

LT Format Overview

Figure 22 shows an overview of the Type 3 long (LT) board.

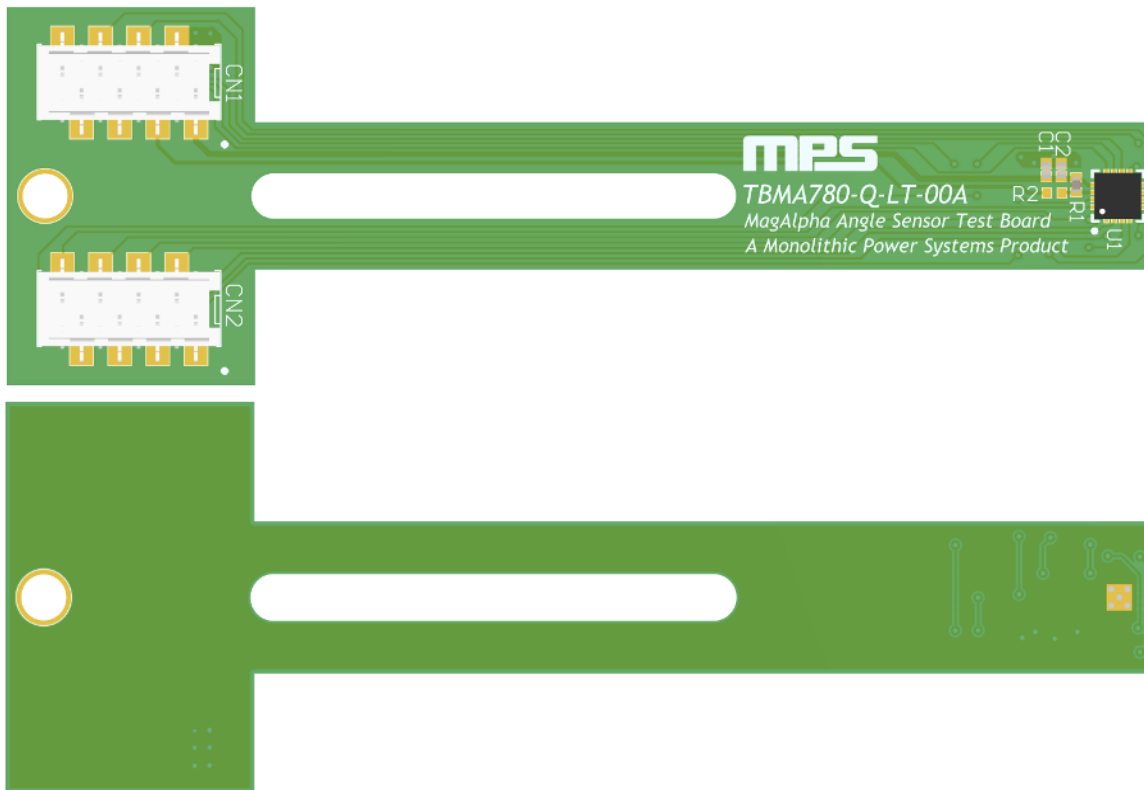

Figure 22: LT Type 3 Board Overview

Schematic

Figure 23 shows a schematic for the Type 3 boards.

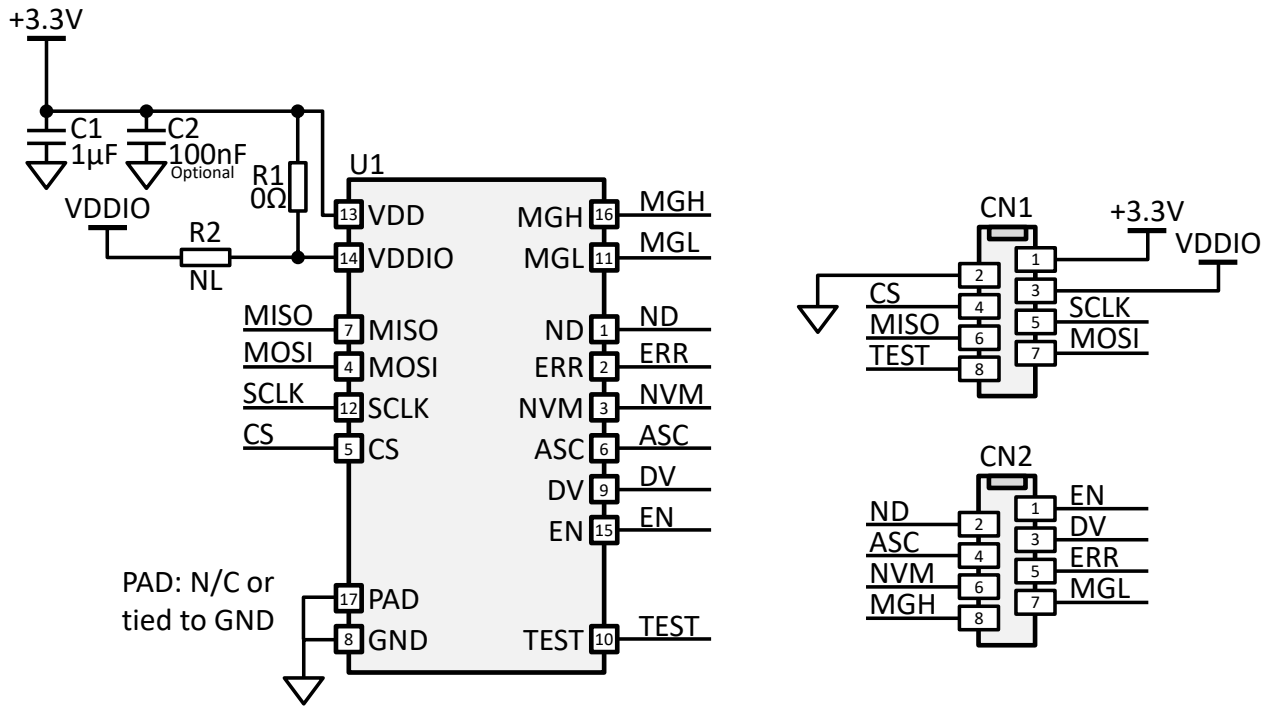

Figure 23: RD/LT Type 3 Schematic

Bill of Materials

Table 6 shows the Type 3 board bill of materials (BOM).

Table 6: Type 3 Board Bill of Materials

Quantity	Designator	Description	Value	Manufacturer	Manufacturer PN
1	C1	Ceramic capacitor, 10V, X6S, 0402	1μF	Murata	GRM155C81A105KA12D
1	C2 (not populated)	Ceramic capacitor, 16V, X7R, 0402	100nF	Murata	GRM155R71C104KA88J
1	R1 (populated), R2 (not populated)	0Ω resistor, 0402	0Ω	Panasonic	ERJ-2GE0R00X
1	U1	MagAlpha magnetic position sensor	MA780	MPS	MA780GQ
2	CN1, CN2 (not populated)	8-position receptacle connector, 0.100" (2.54mm), surface-mount tin		Würth or TE Connectivity	690367280876 or 7-2178711-8

Assembly View

Figure 24 shows the top-side assembly view of the Type 3 round board. Figure 25 shows the top-side assembly view of the Type 3 long board.

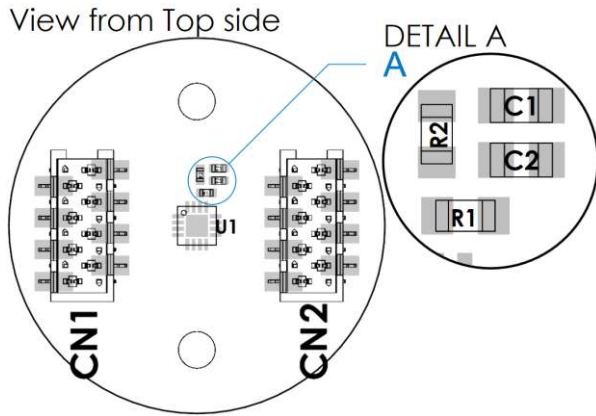

Figure 24: RD Type 3 Assembly View

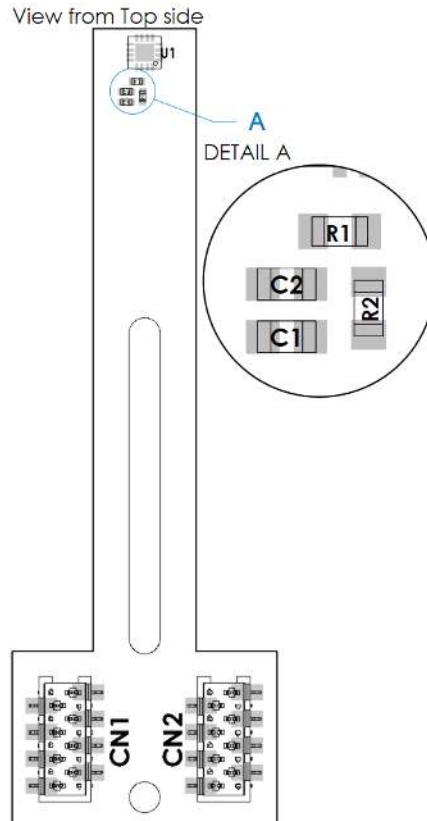

Figure 25: LT Type 3 Assembly View

Mechanical Drawing

Figure 26 shows the top-side mechanical drawing of the Type 3 round board. Figure 27 shows the top-side mechanical drawing of the Type 3 long board.

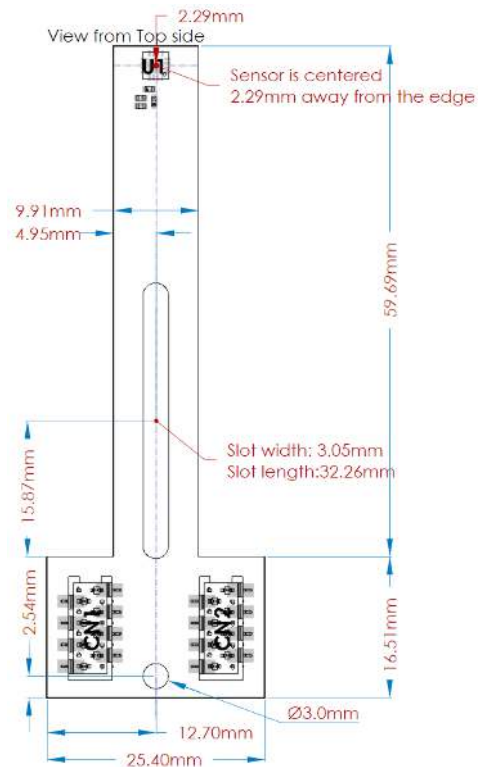
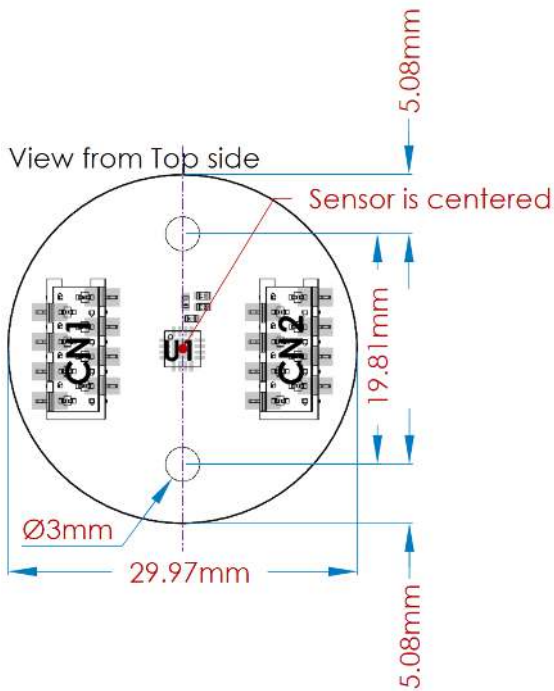
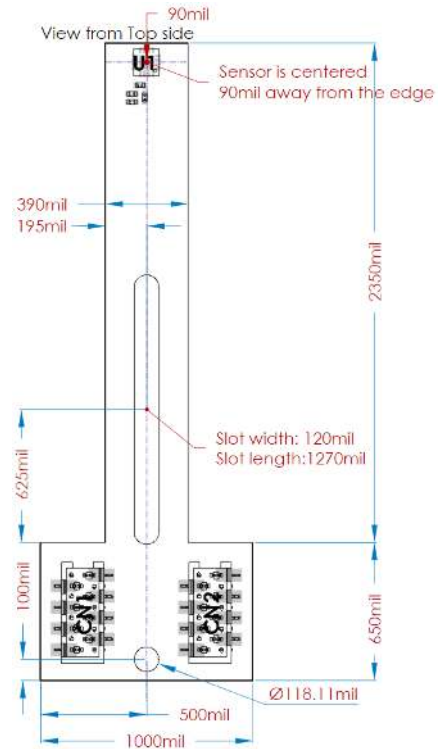
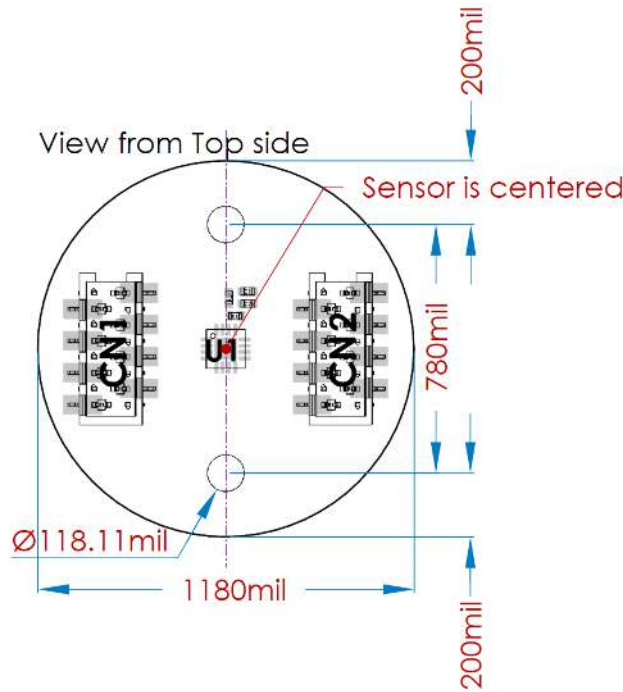

Figure 26: RD Type 3 Mechanical Drawing

Figure 27: LT Type 3 Mechanical Drawing, mil = 0.001" = 0.0254mm

Connector Pinout

Figure 28 shows the Type 3 round board connector pinout. Figure 29 shows the Type 3 long board connector pinout.

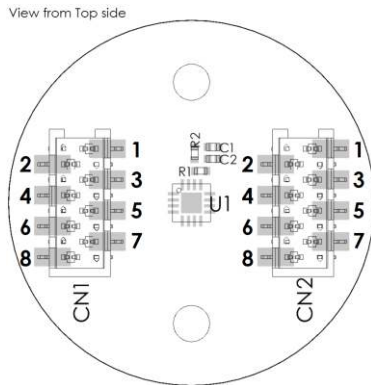

Figure 28: RD Type 3 Connector Pinout

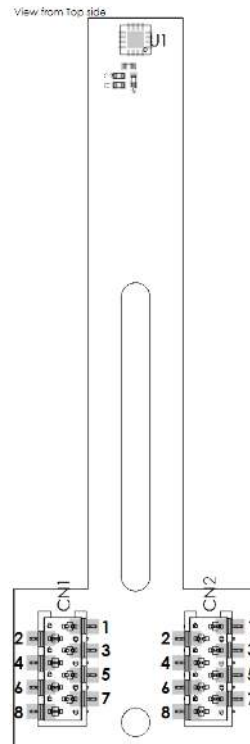

Figure 29: LT Type 3 Connector Pinout

Table 7 shows the Type 3 pin registers.

Table 7: Type 3 Board Connector Pin Registers

Pin	Name	Description
CN1.1	VDD	3.3V supply.
CN1.2	GND	Ground.
CN1.3	VDDIO	1.8V to 3.3V supply for IOs.
CN1.4	CS	Chip select (serial).
CN1.5	SCLK	Clock (serial).
CN1.6	MISO	Master in slave out (serial).
CN1.7	MOSI	Master out slave in (serial).
CN1.8	TEST	Test pin.
CN2.1	EN	Enable (input). Switches the sensor to active mode.
CN2.2	ND	New data (output).
CN2.3	DV	Data valid (output).
CN2.4	ASC	Auto-power cycling mode (input).
CN2.5	ERR	Error flag (output).
CN2.6	NVM	Non-volatile memory (output).
CN2.7	MGL ⁽⁴⁾	Magnetic level low (optional).
CN2.8	MGH ⁽⁴⁾	Magnetic level high (optional).

Note:

4) Availability of this option depends of the MagAlpha part number. Please refer directly to the part datasheet.

BOARD TYPE 4

RD Format Overview

Figure 30 shows an overview of the Type 4 round (RD) board.

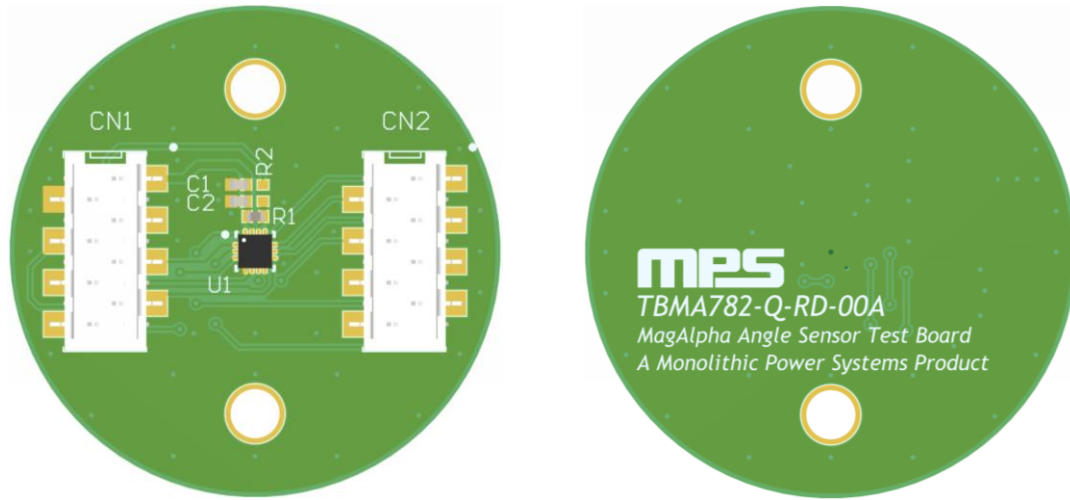

Figure 30: RD Type 4 Board Overview

LT Format Overview

Figure 31 shows an overview of the Type 4 long (LT) board.

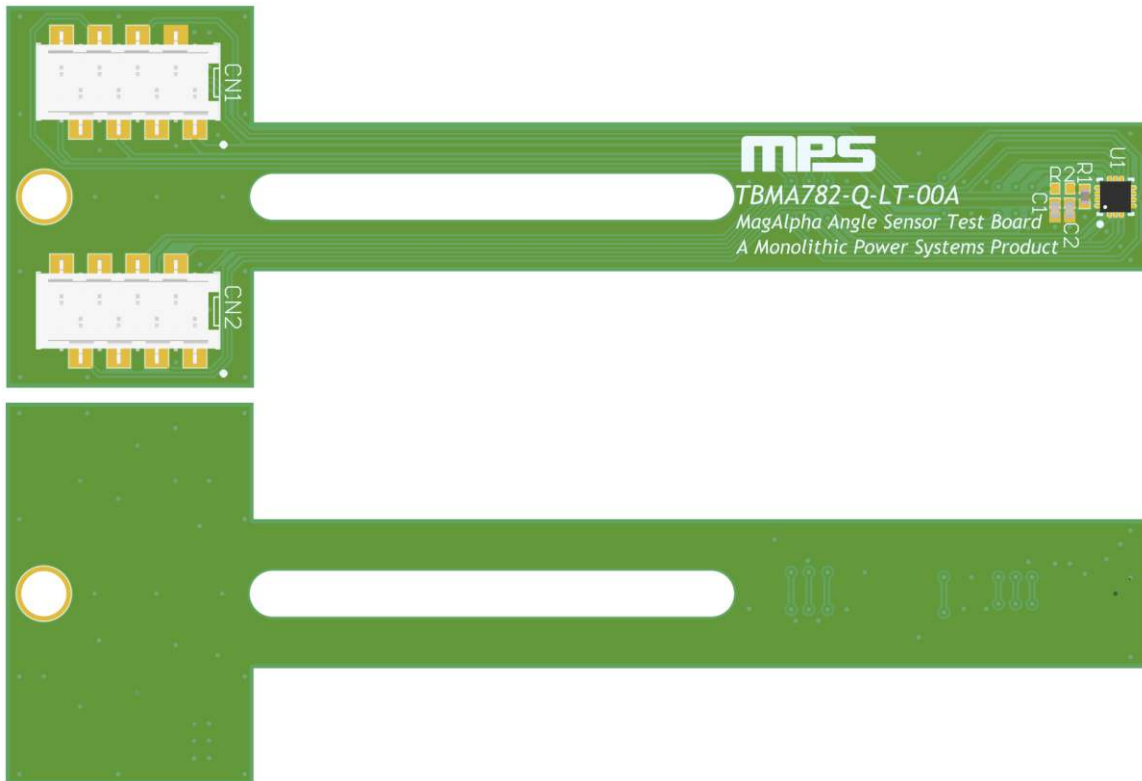

Figure 31: LT Type 4 Board Overview

Schematic

Figure 32 shows a schematic for the Type 4 boards.

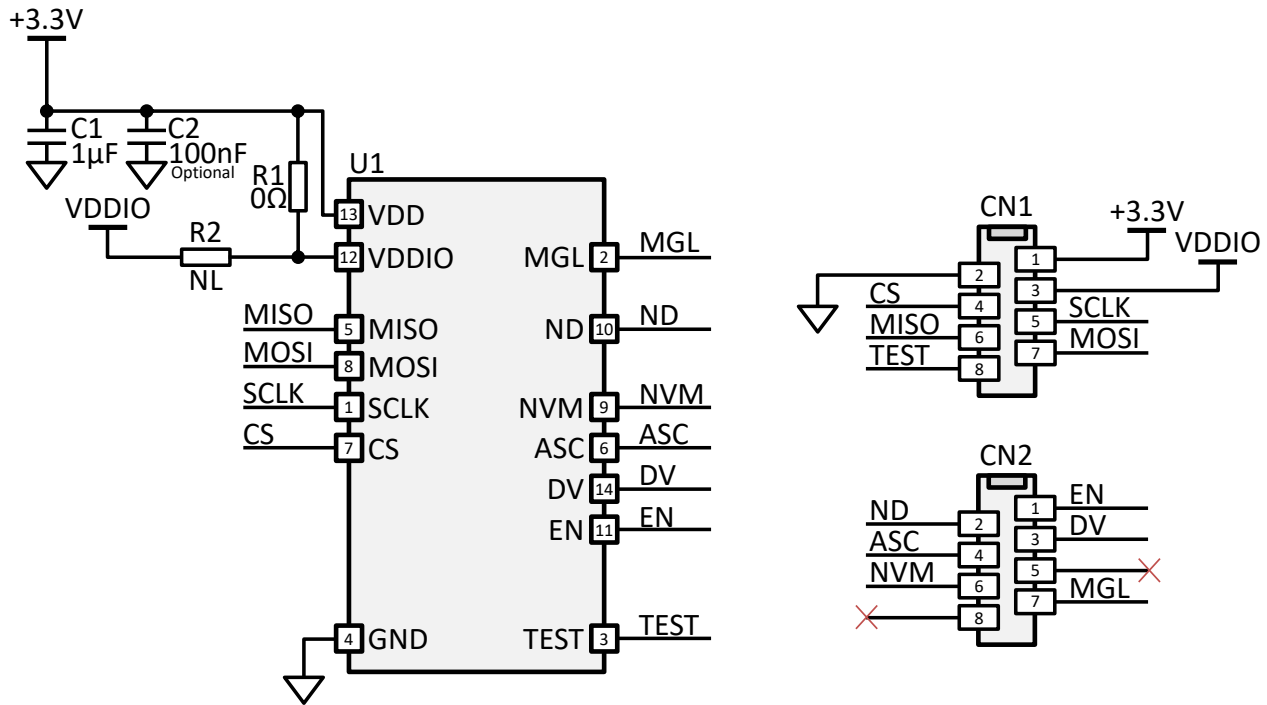

Figure 32: RD/LT Type 4 Schematic

Bill of Materials

Table 8 shows the Type 4 board bill of materials (BOM).

Table 8: Type 4 Board Bill of Materials

Quantity	Designator	Description	Value	Manufacturer	Manufacturer PN
1	C1	Ceramic capacitor, 10V, X6S, 0402	1µF	Murata	GRM155C81A105KA12D
1	C2 (not populated)	Ceramic capacitor, 16V, X7R, 0402	100nF	Murata	GRM155R71C104KA88J
1	R1 (populated), R2 (not populated)	0Ω resistor, 0402	0Ω	Panasonic	ERJ-2GE0R00X
1	U1	MagAlpha magnetic position sensor	MA782	MPS	MA782GGU
2	CN1, CN2 (not populated)	8-position receptacle connector, 0.100" (2.54mm), surface-mount tin		Würth or TE Connectivity	690367280876 or 7-2178711-8

Assembly View

Figure 33 shows the top-side assembly view of the Type 4 round board. Figure 34 shows the top-side assembly view of the Type 4 long board.

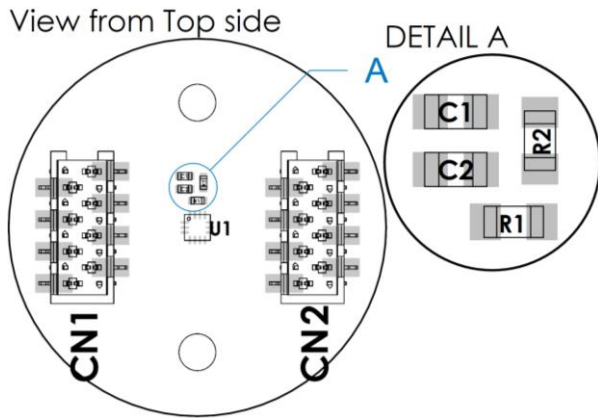

Figure 33: RD Type 4 Assembly View

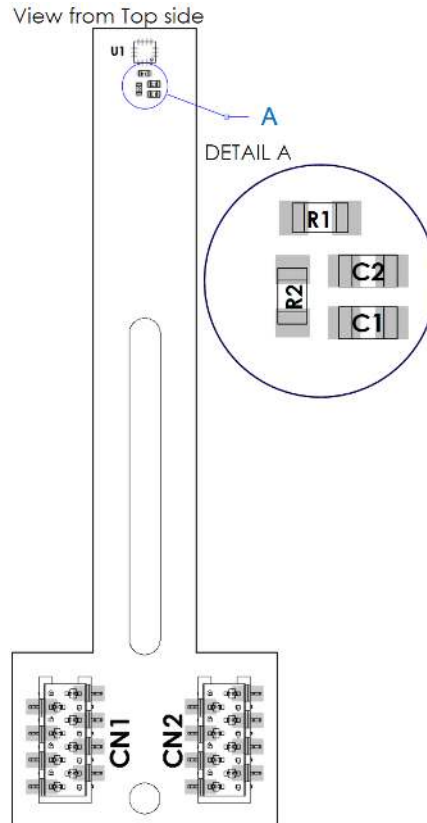

Figure 34: LT Type 4 Assembly View

Mechanical Drawing

Figure 35 shows the top-side mechanical drawing of the Type 4 round board. Figure 36 shows the top-side mechanical drawing of the Type 4 long board.

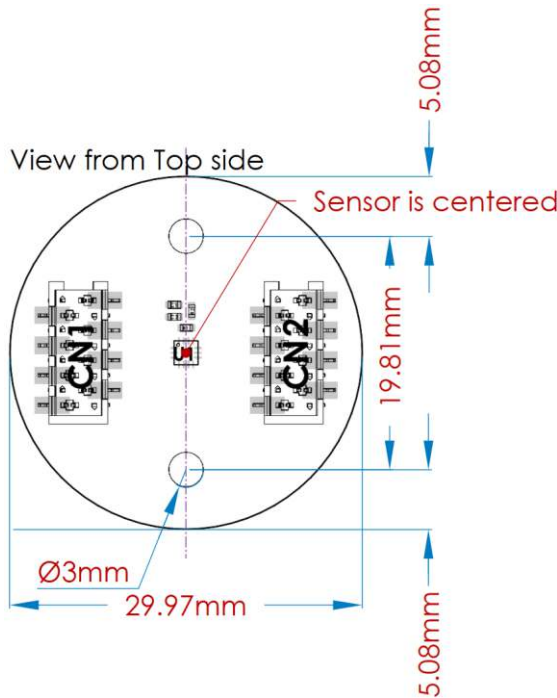
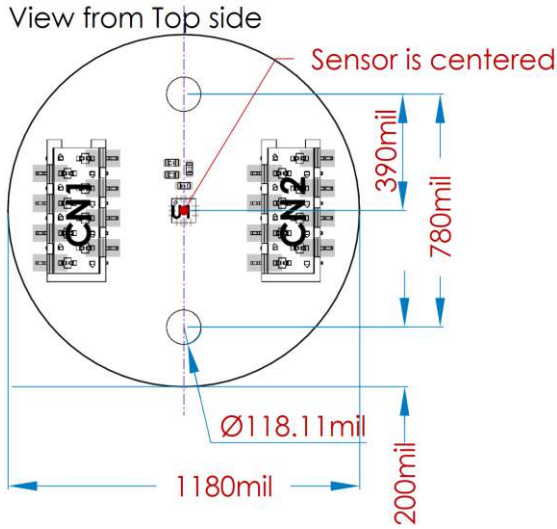

Figure 35: RD Type 4 Mechanical Drawing

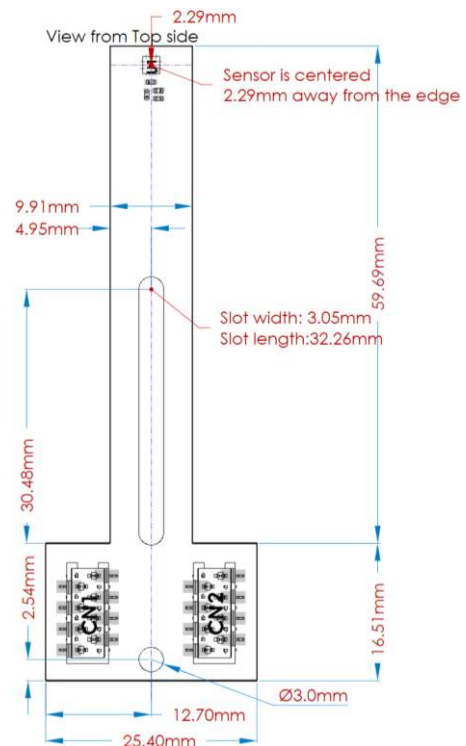
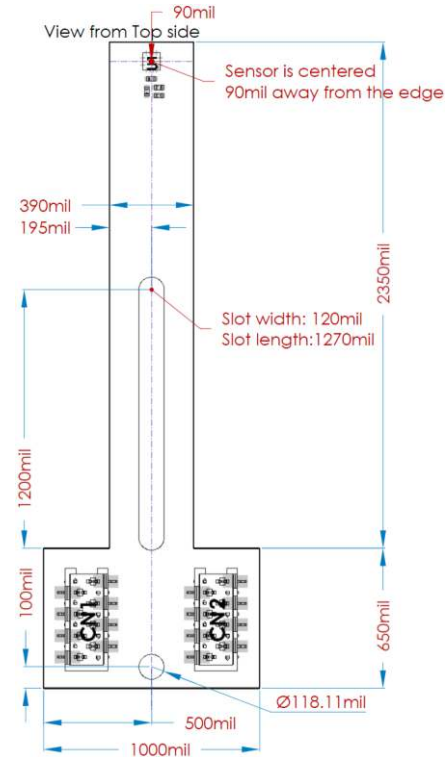

Figure 36: LT Type 4 Mechanical Drawing, mil = 0.001" = 0.0254mm

Connector Pinout

Figure 37 shows the Type 4 round board connector pinout. Figure 38 shows the Type 4 long board connector pinout.

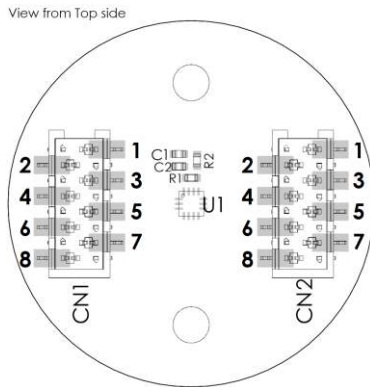

Figure 37: RD Type 4 Connector Pinout

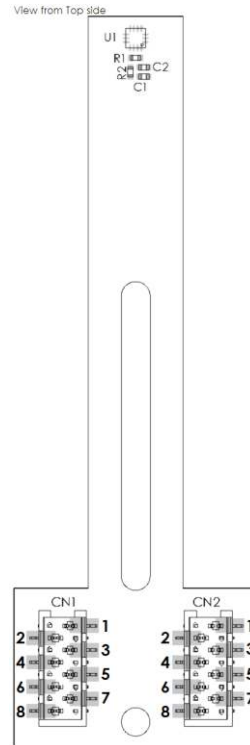

Figure 38: LT Type 4 Connector Pinout

Table 9 shows the Type 4 board pin registers.

Table 9: Type 4 Board Connector Pin Registers

Pin	Name	Description
CN1.1	VDD	3.3V supply.
CN1.2	GND	Ground.
CN1.3	VDDIO	1.8V to 3.3V supply for IOs.
CN1.4	CS	Chip select (serial).
CN1.5	SCLK	Clock (serial).
CN1.6	MISO	Master in slave out (serial).
CN1.7	MOSI	Master out slave in (serial).
CN1.8	TEST	Test pin.
CN2.1	EN	Enable (input). Switches the sensor to active mode.
CN2.2	ND	New data (output).
CN2.3	DV	Data valid (output).
CN2.4	ASC	Auto-power cycling mode (input).
CN2.5	-	-
CN2.6	NVM	Non-volatile memory (output).
CN2.7	MGL ⁽⁵⁾	Magnetic level low (optional).
CN2.8	-	-

Note:

5) Availability of this option depends of the MagAlpha part number. Refer directly to the related part's datasheet.

BOARD TYPE 5

RD Format Overview

Figure 39 shows an overview of the Type 5 round board.

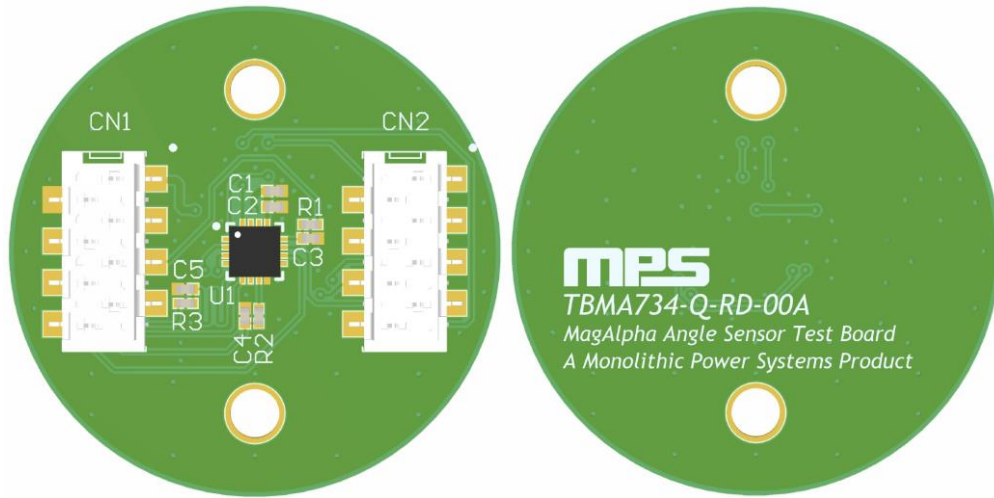

Figure 39: RD Type 5 Board Overview

LT Format Overview

Figure 40 shows an overview of the Type 5 long board.

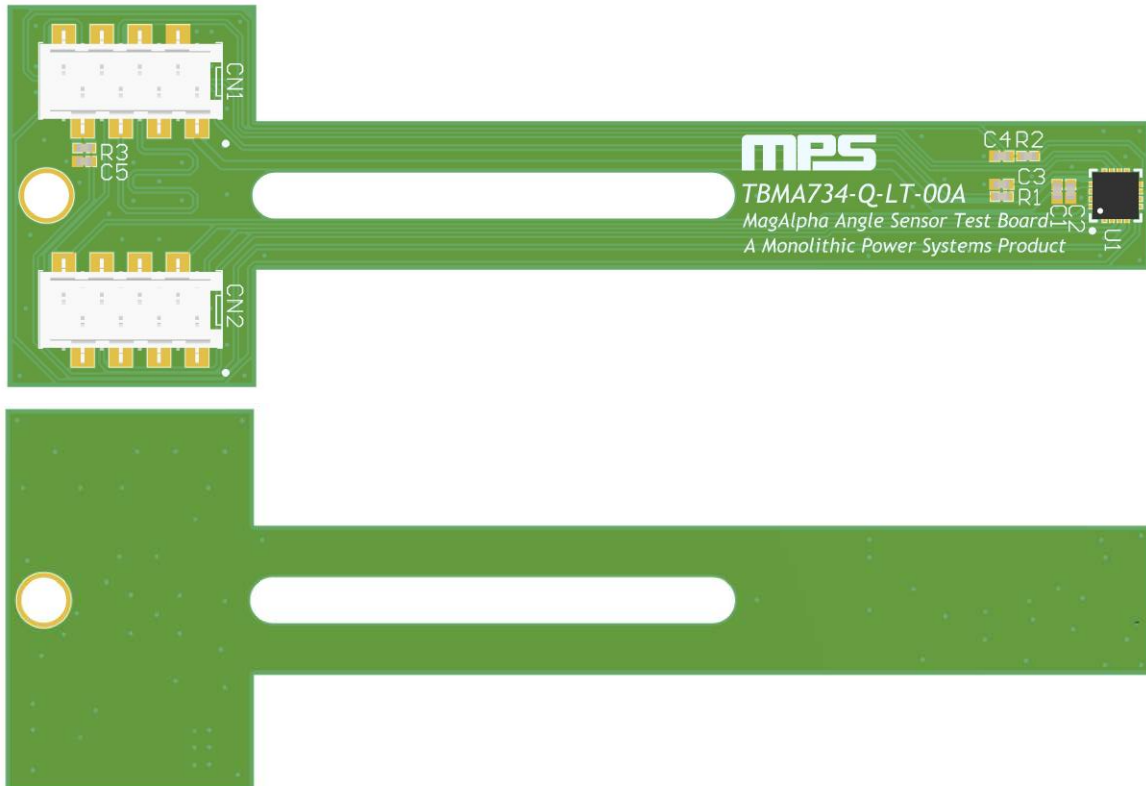

Figure 40: LT Type 5 Board Overview

Schematic

Figure 41 shows a schematic for the Type 5 boards.

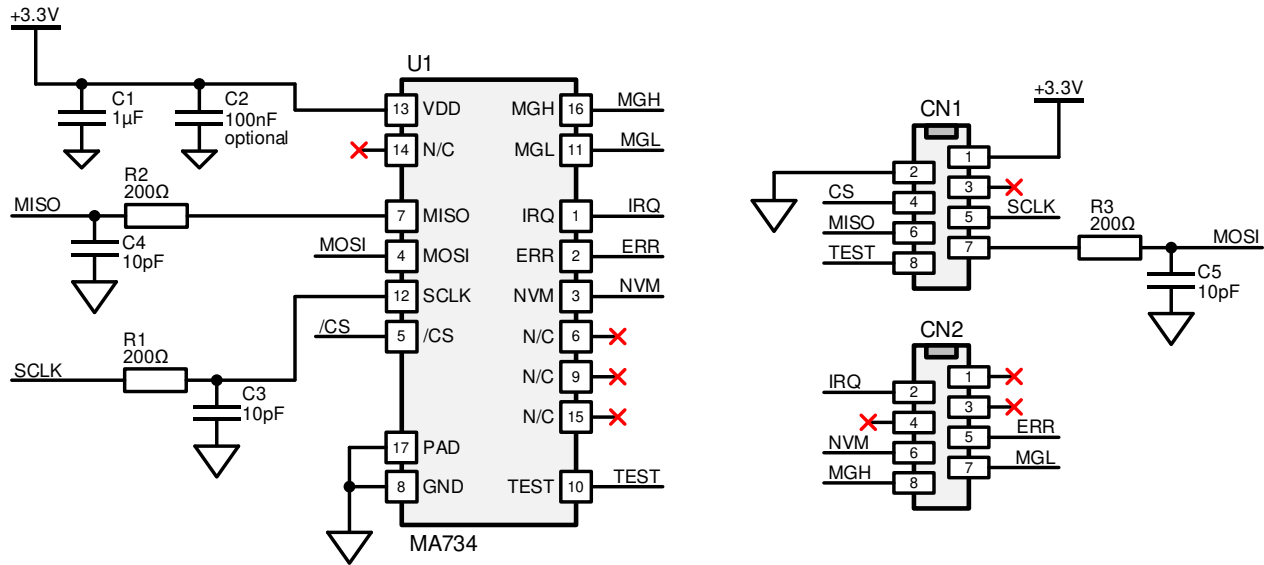

Figure 41: RD/LT Type 5 Schematic

Bill of Materials

Table 10 shows the Type 5 board bill of materials (BOM).

Table 10: Type 5 Board Bill of Materials

Quantity	Designator	Description	Value	Manufacturer	Manufacturer PN
1	C1	Ceramic capacitor, 10V, X6S, 0402	1µF	Murata	GRM155C81A105KA12D
1	C2 (optional)	Ceramic capacitor, 16V, X7R, 0402	100nF	Murata	GRM155R71C104KA88J
3	R1, R2, R3	200Ω resistor, 0402	200Ω	Yageo	RC0402FR-07200RL
3	C3, C4, C5	Ceramic capacitor, 50V, C0G, 0402	10pF	Yageo	CC0402JRNPO9BN100
1	U1	MagAlpha magnetic position sensor	MA734	MPS	MA734
2	CN1, CN2	8-position receptacle connector, 0.100" (2.54mm), surface-mount tin		Würth or TE Connectivity	690367280876 or 7-2178711-8

Assembly View

Figure 42 shows the top-side assembly view of the Type 5 round board. Figure 43 shows the top-side assembly view of the Type 5 long board.

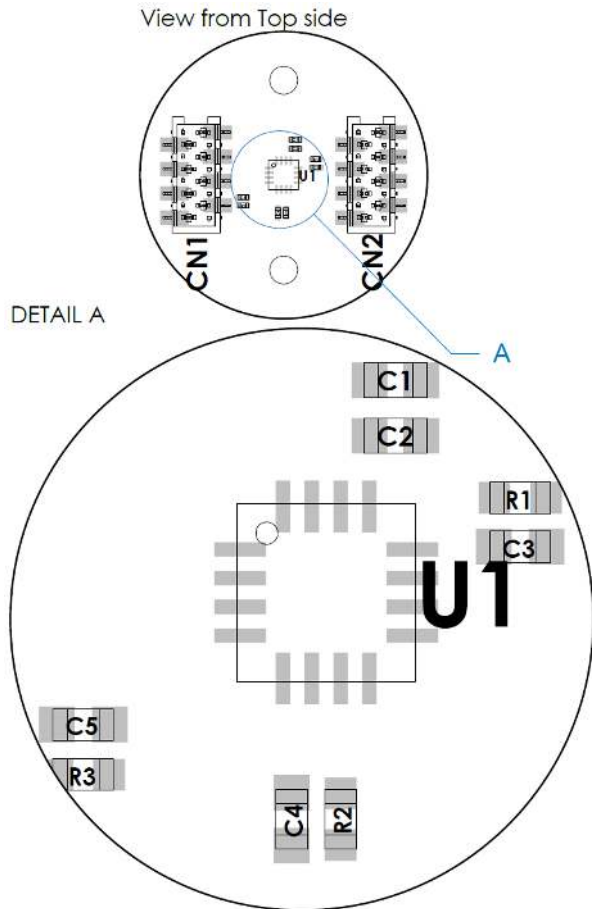

Figure 42: RD Type 5 Assembly View

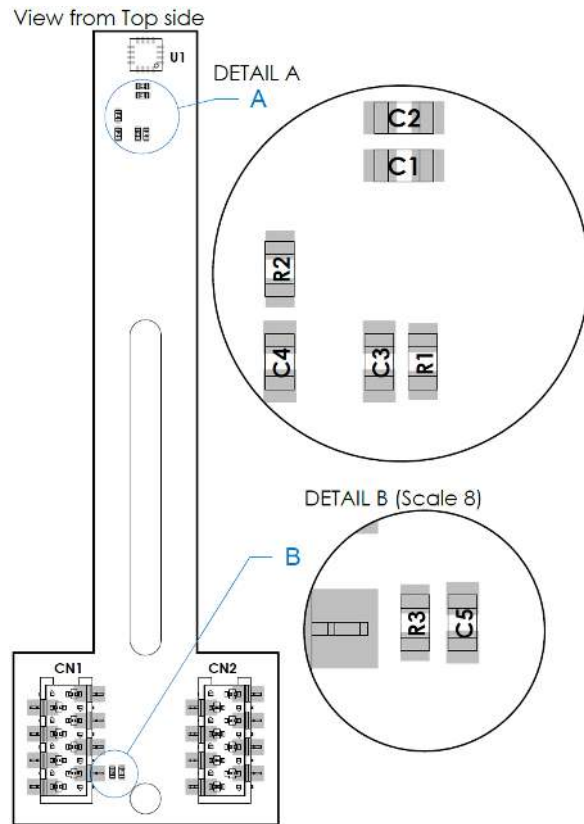

Figure 43: LT Type 5 Assembly View

Mechanical Drawing

Figure 44 shows the top-side mechanical drawing of the Type 5 round board. Figure 45 shows the top-side mechanical drawing of the Type 5 long board.

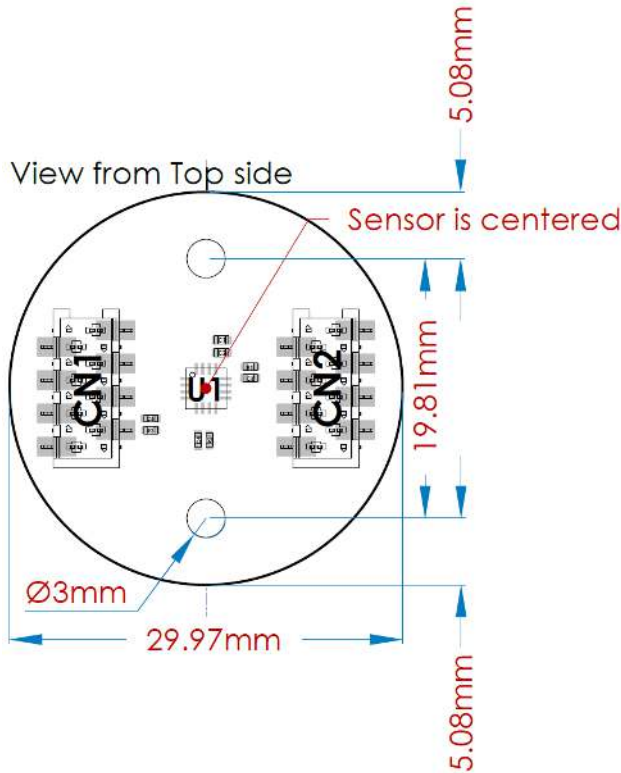
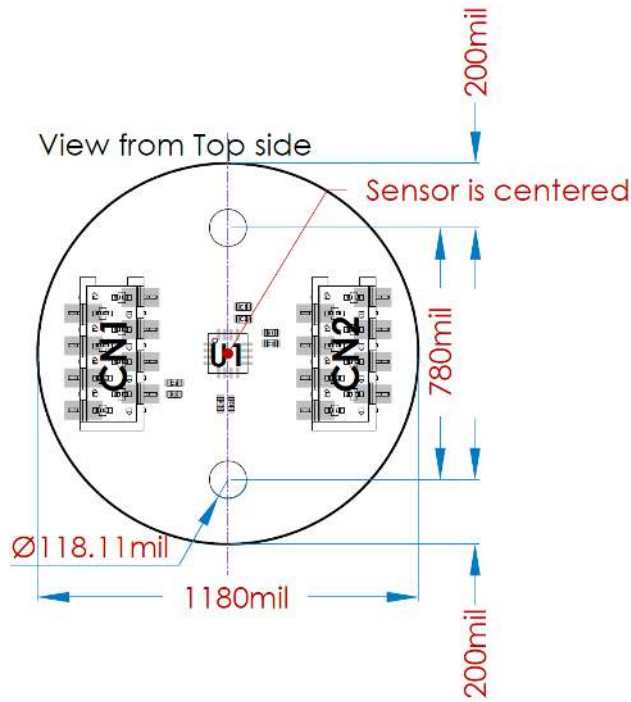

Figure 44: RD Type 5 Mechanical Drawing

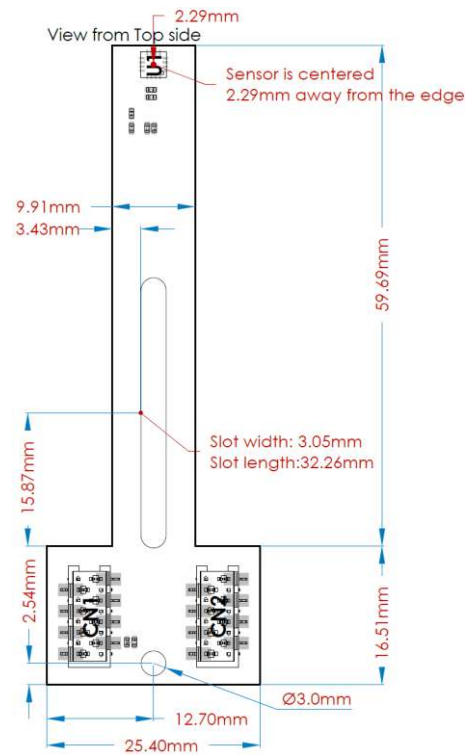
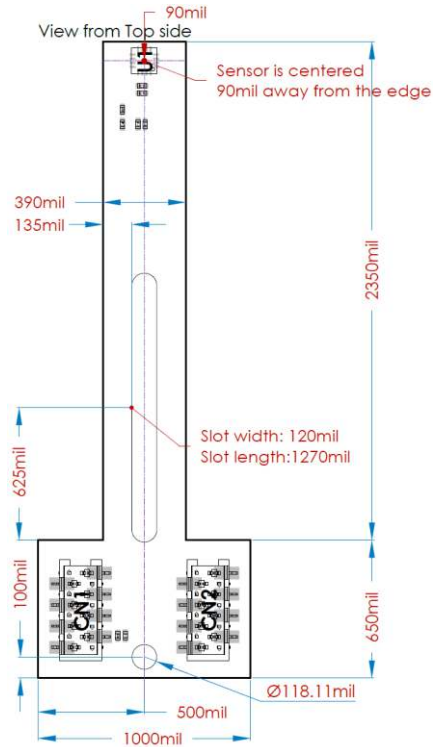

Figure 45: LT Type 5 Mechanical Drawing, mil = 0.001" = 0.0254mm

Connector Pinout

Figure 46 shows the Type 5 round board connector pinout. Figure 47 shows the Type 5 long board connector pinout.

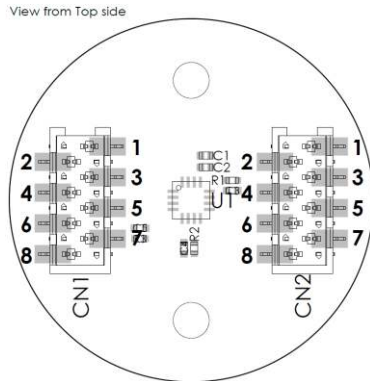

Figure 46: RD Type 5 Connector Pinout

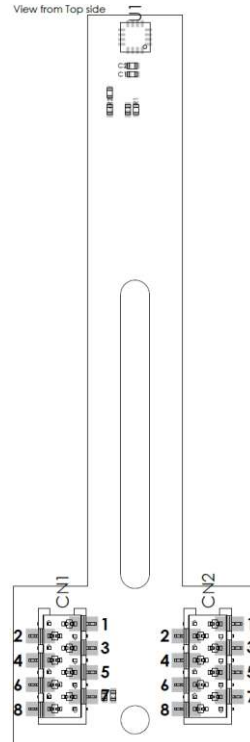

Figure 47: LT Type 5 Connector Pinout

Table 11 shows the Type 5 pin registers.

Table 11: Type 5 Board Connector Pin Registers

Pin	Name	Description
CN1.1	VDD	3.3V supply.
CN1.2	GND	Ground.
CN1.3	NC	Not connected.
CN1.4	CS	Chip select (serial).
CN1.5	SCLK	Clock (serial).
CN1.6	MISO	Master in, slave out (serial).
CN1.7	MOSI	Master out, slave in (serial).
CN1.8	TEST	Test pin.
CN2.1	NC	Not connected.
CN2.2	IRQ	Interrupt on angle change (output).
CN2.3	NC	Not connected.
CN2.4	NC	Not connected.
CN2.5	ERR	Error flag (output).
CN2.6	NVM	Non-volatile memory (output).
CN2.7	MGL	Magnetic level low (optional).
CN2.8	MGH	Magnetic level high (optional).

MAGNET SUPPLIERS

A selection of magnets are available with the MPS MAG10 magnet product family. This family offers three different magnet geometries: cylinder, ring, and half-cylinder. Figure 48 shows the available magnet geometries. The MPS MAG10 magnet product family can be purchased directly from MPS.

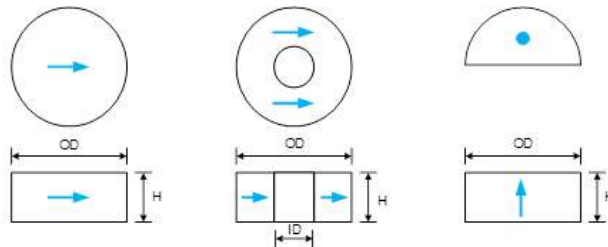

Figure 48: MPS MAG10 Magnet Geometries

Visit our website learn more about our magnet portfolio:

<https://www.monolithicpower.com/en/products/sensors/position-sensors/position-sensor-magnets.html>

If the magnet required for your application is not listed on our website, consider the following non-exhaustive list of possible magnet suppliers (see Table 12). The magnetization direction must be chosen wisely given that most sold magnets are often axially magnetized, which is not a magnetization direction typically required in magnetic angle-sensing applications. Angle-sensing applications typically use diametrically magnetized magnets.

Table 12: Magnet Suppliers

Company	Website	Address	Comments
Bomatec AG	www.bomatec.com	Hofstrasse 1, 8181 Höri, Switzerland	An MPS partner for many projects.
Maurer Magnetics AG	www.maurermagnetic.ch	Industriestrasse 8 8627 Grüningen, Switzerland	Maurer offers a selection of diametrically magnetized magnets in stock.
Arnold Technologies AG	www.arnoldmagnetics.com	Hübelacherstrasse 15 5242 Birr-Lupfig, Switzerland	
Dexter Magnetic Technologies	www.dextermag.com	1050 Morse Avenue, Elk Grove Village, IL 60007-5110 USA	
JPMF	www.jpmp.com.cn	8 LongWan Road, Jiangmen City, GuangDong Province, China	Magnet overmolding.
IMA	www.imamagnets.com	Avda. Cataluña 5, 08291 Ripollet, Barcelona, Spain	Magnet overmolding, magnetic tapes.

Revision History

Revision #	Revision Date	Description	Pages Updated
0.2	3/15/2017	Initial Release	-
1.0	9/17/2020	Added TBMAQ family into list of board types; expanded Magnet Suppliers section and modified list of magnet suppliers; grammar and formatting updates	All
1.1	9/22/2021	Added Type 5 Board (MA734)	4, 25–29

Notice: The information in this document is subject to change without notice. Please contact MPS for current specifications. Users should warrant and guarantee that third-party Intellectual Property rights are not infringed upon when integrating MPS products into any application. MPS will not assume any legal responsibility for any said applications.