

# FD6M045N06

## 60V/60A Synchronous Rectifier Module

### General Features

- Very High Rectification Efficiency at Output 12V
- Integrated Solution for Saving Board Space
- RoHS Compliant



### General Description

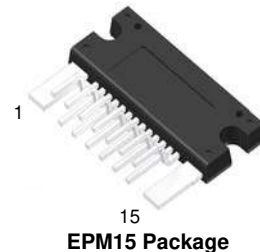
The FD6M045N06 is one product in the Power-SPM™ family that Fairchild has newly developed and designed to be most suitable for more compact and more efficient synchronous rectification applications such as internet server power supplies and telecom system power supplies. For higher efficiency, it includes built-in very low  $R_{DS(ON)}$  MOSFETs. This Power-SPM device can be used in the secondary side of the PWM transformer of forward/bridge converter to provide high current rectification at output voltages ranging from 12 Volts down to 5 Volts. With this product, it is possible to design the secondary side of power supply systems with reduced parasitic elements resulting in minimized voltage spike and EMI noise.

### MOSFET Features

- $V_{DSS} = 60V$
- $Q_{G(TOTAL)} = 66nC(Typ.)$ ,  $V_{GS} = 10V$
- $R_{DS(ON)} = 3.6m\Omega(Typ.)$ ,  $V_{GS} = 10V$ ,  $I_D = 40A$
- Low Miller Charge
- Low  $Q_{rr}$  Body Diode
- UIS Capability (Single Pulse and Repetitive Pulse)
- Fully Isolated Package

### Applications

- High Current Isolated Converter
- Distributed Power Architectures
- Synchronous Rectification
- DC/DC Converter
- Battery Supplied Application
- ORing MOSFET



### Block Diagram

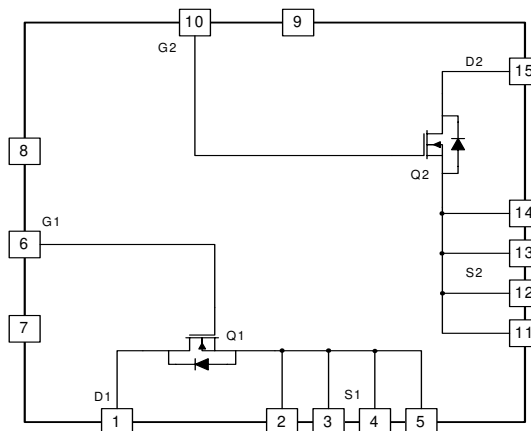


Figure 1. FD6M045N06 Module Block Diagram

## Pin Configuration and Pin Description

Top View

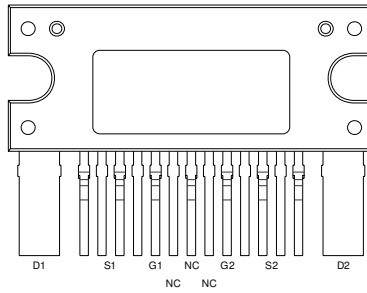


Figure 2. Pinmap of FD6M045N06

Pin Number	Pin Name	Pin Description
1	D1	Drain of Q1, MOSFET
2 ~ 5	S1	Source of Q1, MOSFET
6	G1	Gate of Q1, MOSFET
7	NC	No Connection
8	NC	No Connection
9	NC	No Connection
10	G2	Gate of Q2, MOSFET
11 ~ 14	S2	Source of Q2, MOSFET
15	D2	Drain of Q2, MOSFET

### Absolute Maximum Ratings $T_C = 25^\circ\text{C}$ , Unless Otherwise Specified

Symbol	Parameter	Rating	Unit
$V_{DS}$	Drain to Source Voltage (Note1)	60	V
$V_{GS}$	Gate to Source Voltage	$\pm 20$	V
$I_D$	Drain Current, Continuous ( $V_{GS} = 10\text{V}$ ) (Note1)	60	A
$E_{AS}$	Single Pulse Avalanche Energy (Note1,2)	794	mJ
$T_J, T_{STG}$	Operating and Storage Temperature Range	-40 ~ 150	$^\circ\text{C}$

### Thermal Resistance

Symbol	Parameter	Min.	Typ.	Max.	Unit
$R_{\theta JC}$	Junction to Case Thermal Resistance (Note1)	-	-	3.9	$^\circ\text{C}/\text{W}$

**Note:**

- Each MOSFET Switch
- Starting  $T_J = 25^\circ\text{C}$ ,  $V_D = 40\text{V}$ ,  $L = 0.25\text{mH}$ ,  $I_{AS} = 46\text{A}$

**Electrical Characteristics**  $T_C = 25^\circ\text{C}$ , Unless Otherwise Specified

Symbol	Parameter	Test Conditions	Min.	Typ.	Max.	Units
--------	-----------	-----------------	------	------	------	-------

**Synchronous Rectifier Switch Part** (Each Switch)

$BV_{DSS}$	Drain to Source Breakdown Voltage	$I_D = 250\mu\text{A}$ , $V_{GS} = 0\text{V}$	60	-	-	V
$I_{DSS}$	Zero Gate Voltage Drain Current	$V_{GS} = 0\text{V}$ , $V_{DS} = 48\text{V}$	-	-	1	$\mu\text{A}$
$I_{GSS}$	Gate to Source Leakage Current	$V_{GS} = \pm 20\text{V}$	-	-	$\pm 100$	nA
$V_{GS(TH)}$	Gate Threshold Voltage	$V_D = 20\text{V}$ , $I_{DS} = 250\mu\text{A}$	2.0	-	4.0	V
$R_{DS(ON)}$	Drain to Source On Resistance	$I_D = 40\text{A}$ , $V_{GS} = 10\text{V}$	-	3.55	4.5	m $\Omega$
			$T_J = 150^\circ\text{C}$	-	6.7	

**Dynamic Characteristics**

$C_{ISS}$	Input Capacitance	$V_{DS} = 25\text{V}$ , $V_{GS} = 0\text{V}$ $f = 1\text{MHz}$	-	3890	-	pF
$C_{OSS}$	Output Capacitance		-	755	-	pF
$C_{RSS}$	Reverse Transfer Capacitance		-	270	-	pF
$Q_{g(TOT)}$	Total Gate Charge at 10V	$V_{GS} = 0\text{V}$ to 10V	-	66	87	nC
$Q_{g(TH)}$	Threshold Gate Charge	$V_{GS} = 0\text{V}$ to 2V	-	7	10	nC
$Q_{gs}$	Gate to Source Gate Charge	$V_{DD} = 40\text{V}$ $I_D = 40\text{A}$ $I_g = 1.0\text{mA}$	-	18	-	nC
$Q_{gs2}$	Gate Charge Threshold to Plateau		-	11	-	nC
$Q_{gd}$	Gate to Drain "Miller" Charge		-	20	-	nC

**Switching Characteristics ( $V_{GS} = 10\text{V}$ )**

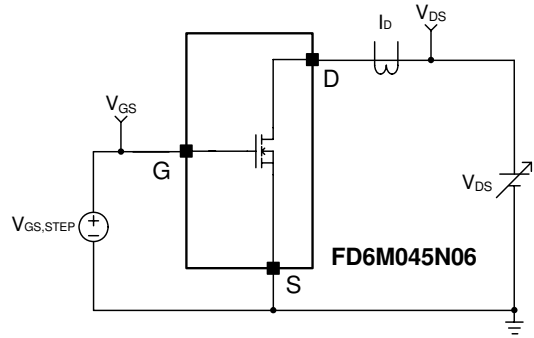
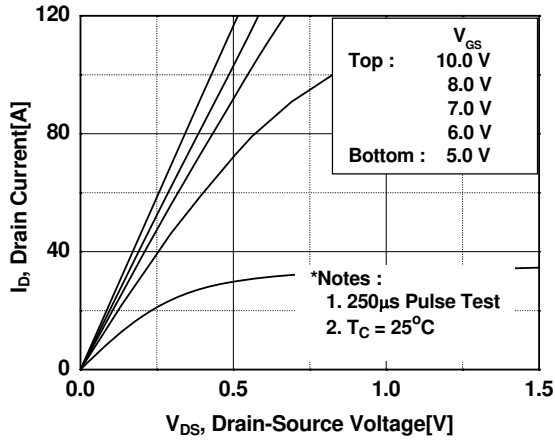
$t_{ON}$	Turn-On Time	$I_D = 40\text{A}$ $V_{GS} = 10\text{V}$ , $V_{DD} = 40\text{V}$ , $R_G = 5\Omega$	-	-	60	ns
$t_{d(on)}$	Turn-On Delay Time		-	18	-	ns
$t_r$	Rise Time		-	19	-	ns
$t_{d(off)}$	Turn-Off Delay Time		-	35	-	ns
$t_f$	Fall Time		-	23	-	ns
$t_{OFF}$	Turn-Off Time		-	-	100	ns

**Drain-Source Diode Characteristics**

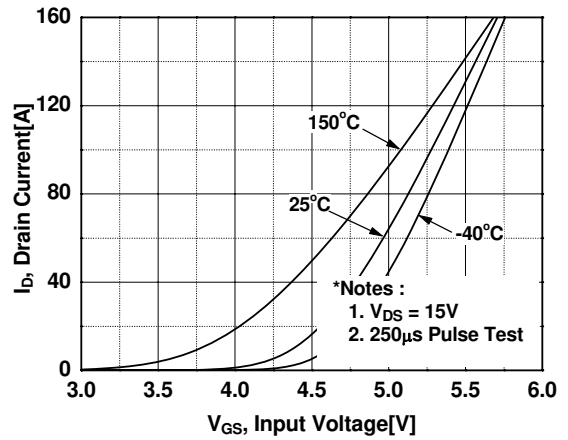
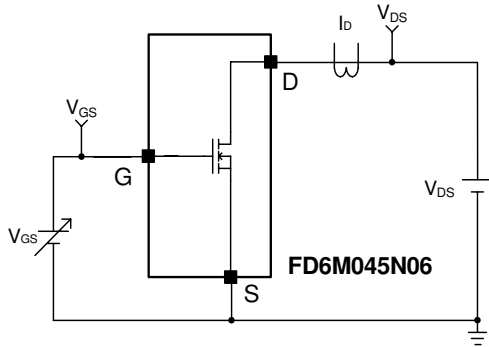
$V_{SD}$	Source to Drain Diode Voltage	$I_{SD} = 80\text{A}$ , $V_{GS} = 0\text{V}$	-	-	1.25	V
		$I_{SD} = 40\text{A}$ , $V_{GS} = 0\text{V}$	-	-	1.0	
$t_{rr}$	Reverse Recovery Time	$I_{SD} = 40\text{A}$ , $dI_{SD}/dt = 100\text{A}/\mu\text{s}$	-	33	-	ns
$Q_{rr}$	Reverse Recovery Charge	$I_{SD} = 40\text{A}$ , $dI_{SD}/dt = 100\text{A}/\mu\text{s}$	-	34	-	nC

**Typical Performance Characteristics** Each Switch, Unless Otherwise Specified

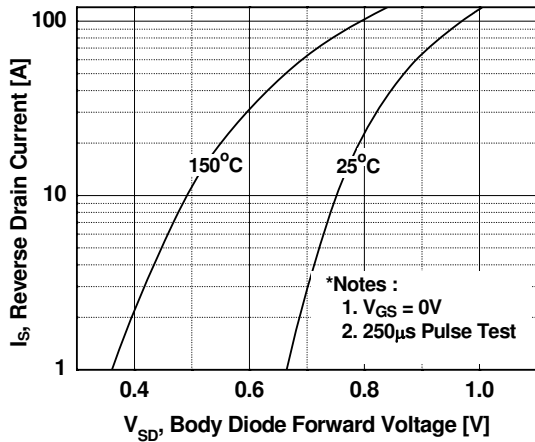
**Figure 3. On-Region Characteristics**



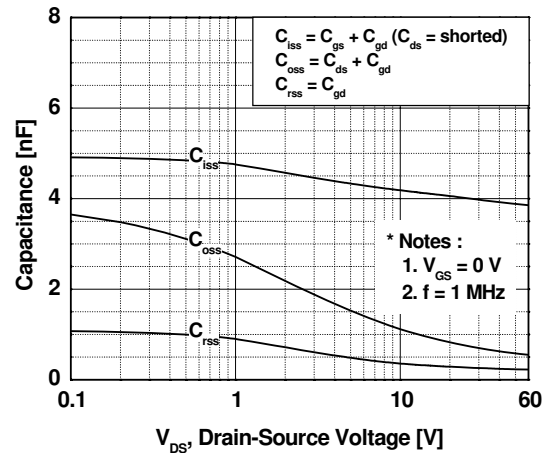
**Figure 4. Transfer Characteristics**



**Figure 5. Body Diode Forward Voltage Variation vs. Source Current and Temperature**



**Figure 6. Output Capacitance Characteristics**



Typical Performance Characteristics (Continued)

Figure 7. Breakdown Voltage Variation vs. Temperature

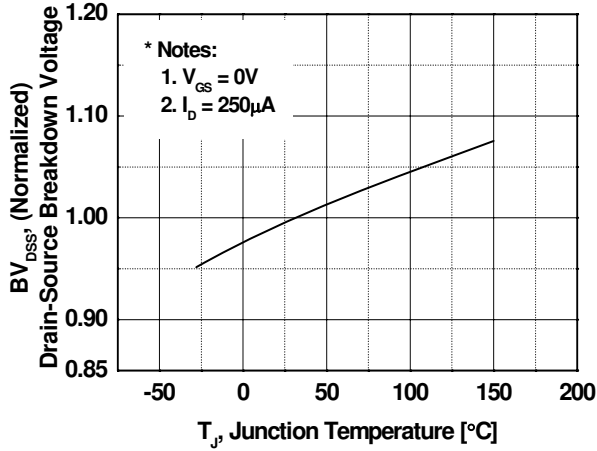


Figure 8. On-Resistance Variation vs. Temperature

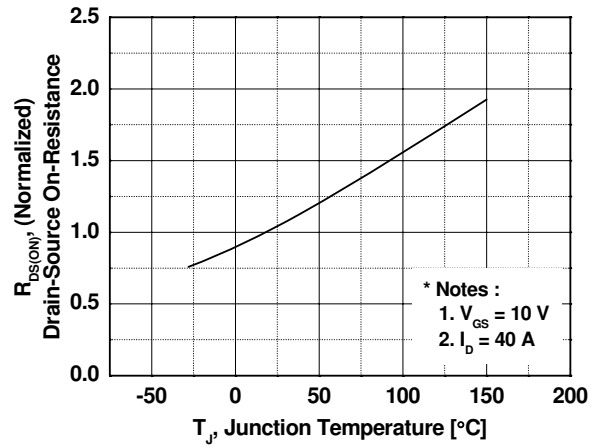


Figure 9. Transient Thermal Response Curve

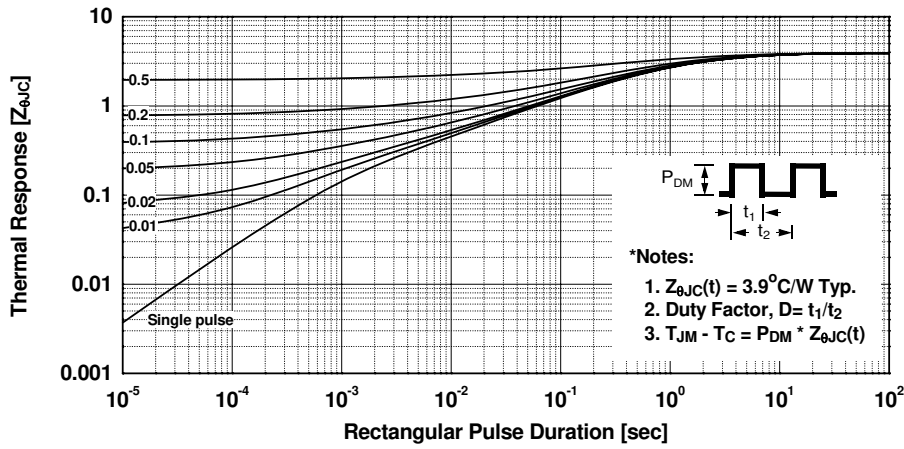


Figure 10. Maximum Safe Operating Area

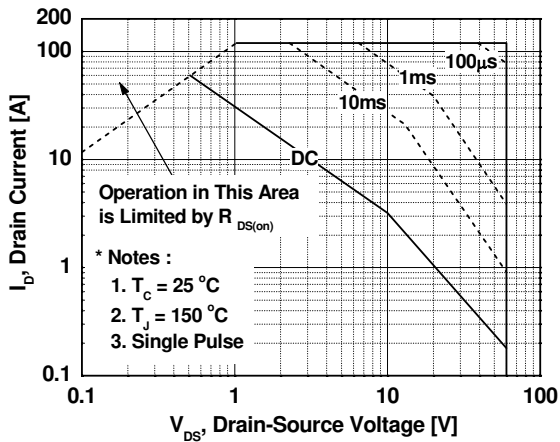
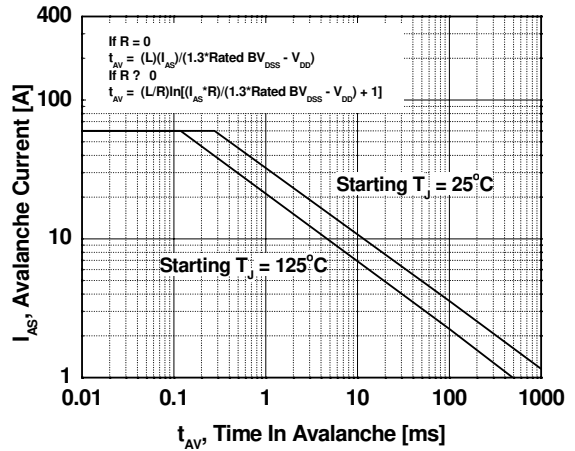
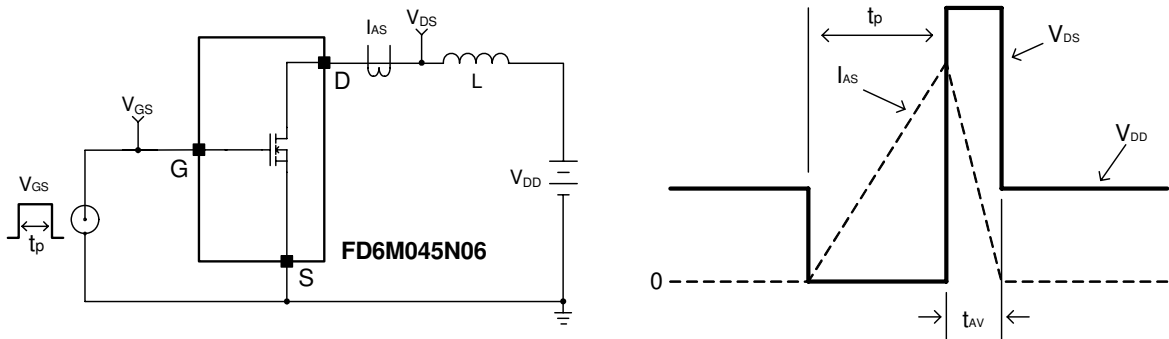


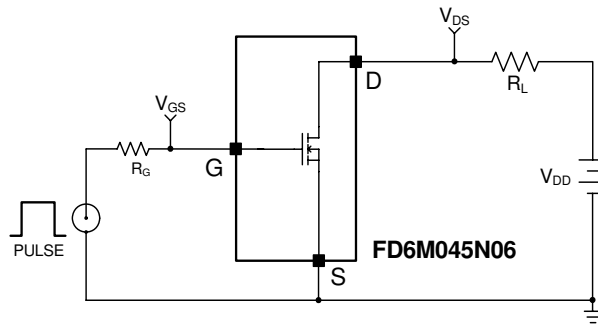
Figure 11. Unclamped Inductive Switching Capability



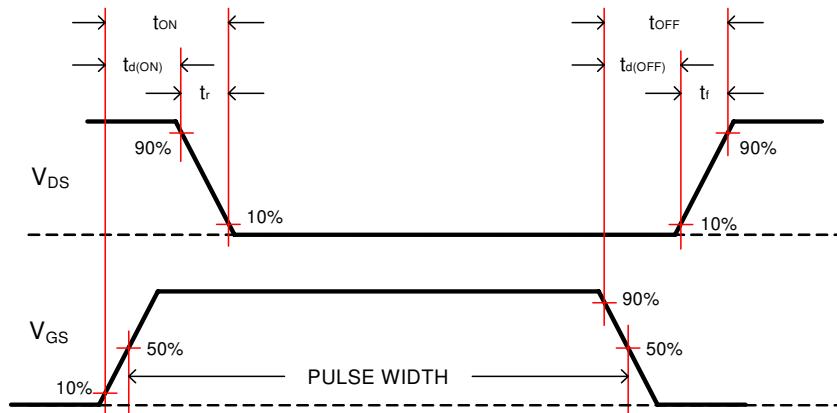
### AC Test Circuits and Waveforms



**Figure 12. Unclamped Inductive Switching Test Circuit and Waveforms**

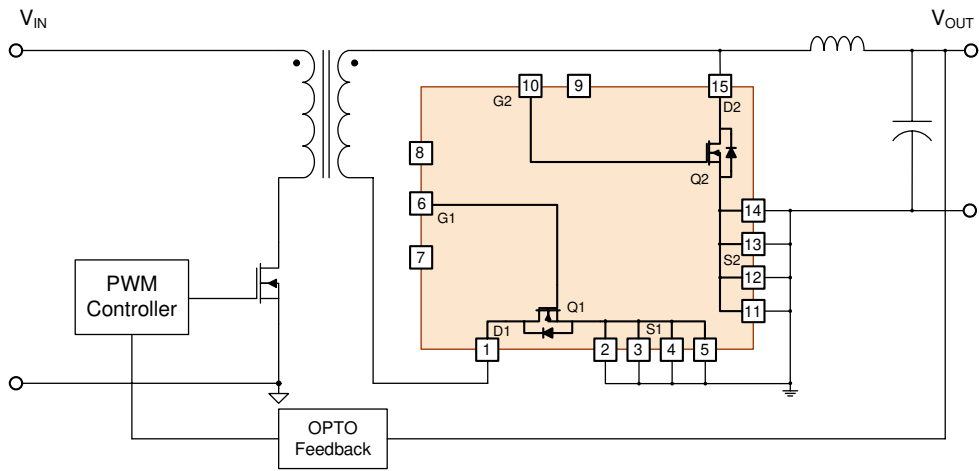


**Figure 13. Switching Test Circuit**

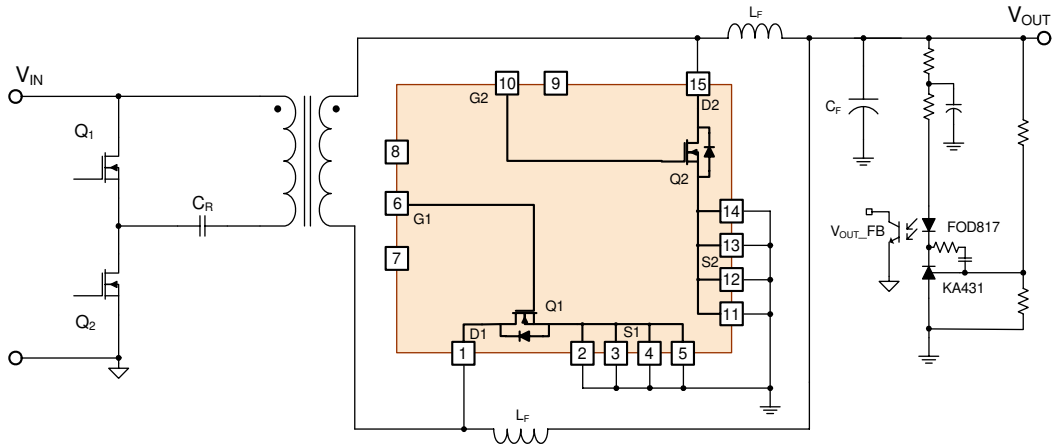


**Figure 14. Switching Test Waveforms**

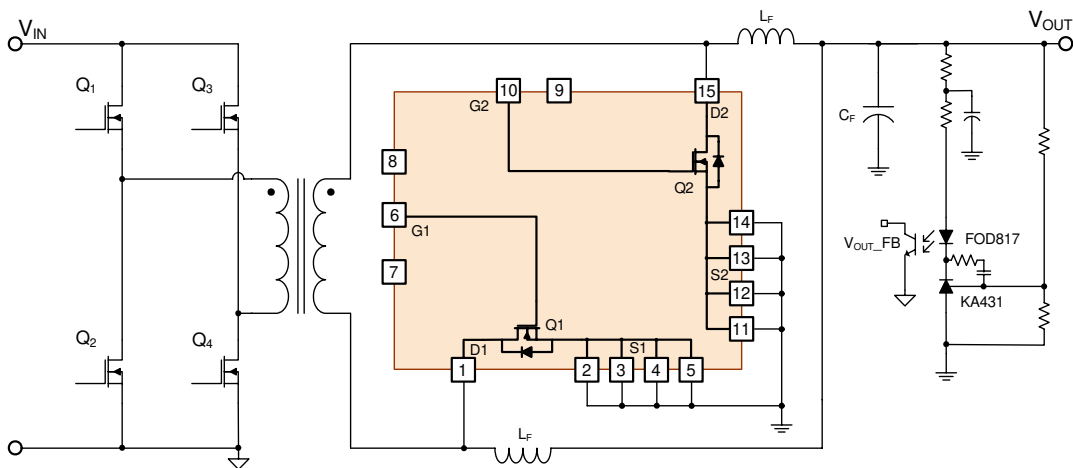
**Application circuits**



**Figure 3. Application Circuit of Forward Converter with FD6M045N06**



**Figure 4. Application Circuit of Asymmetrical HB Converter with FD6M045N06**



**Figure 5. Application Circuit of Full Bridge Converter with FD6M045N06**

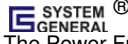










**TRADEMARKS**

The following includes registered and unregistered trademarks and service marks, owned by Fairchild Semiconductor and/or its global subsidiaries, and is not intended to be an exhaustive list of all such trademarks.

- |   |   |                            |   |
|---|---|----------------------------|---|
| ACEx®   | FPS™  | PDP-SPM™                   | SupreMOS™   |
| Build it Now™   | FRFET®  | Power220®                  | SyncFET™  |
| CorePLUS™   | Global Power Resource <sup>SM</sup>   | POWEREDGE®                 |  SYSTEM GENERAL®     |
| CROSSVOLT™  | Green FPS™  | Power-SPM™                 | The Power Franchise®  |
| CTL™  | Green FPS™ e-Series™  | PowerTrench®               |  the power franchise |
| Current Transfer Logic™   | GTO™  | Programmable Active Droop™ | TinyBoost™  |
| EcoSPARK®   | <i>i-Lo</i> ™   | QFET®                      | TinyBuck™   |
| EZSWITCH™ *   | IntelliMAX™   | QST™                       | TinyLogic®  |
|  ™ | ISOPLANAR™  | QT Optoelectronics™        | TINYOPTO™   |
|  ™ | MegaBuck™   | Quiet Series™              | TinyPower™  |
| Fairchild®  | MICROCOUPLER™   | RapidConfigure™            | TinyPWM™  |
| Fairchild Semiconductor®  | MicroFET™   | SMART START™               | TinyWire™   |
| FACT Quiet Series™  | MicroPak™   | SPM®                       | μSerDes™  |
| FACT®   | MillerDrive™  | STEALTH™                   | UHC®  |
| FAST®   | Motion-SPM™   | SuperFET™                  | Ultra FRFET™  |
| FastvCore™  | OPTOLOGIC®  | SuperSOT™-3                | UniFET™   |
| FlashWriter® *  | OPTOPLANAR®  | SuperSOT™-6                | VCX™  |
|   |   | SuperSOT™-8                |   |

\* EZSWITCH™ and FlashWriter® are trademarks of System General Corporation, used under license by Fairchild Semiconductor.

**DISCLAIMER**

FAIRCHILD SEMICONDUCTOR RESERVES THE RIGHT TO MAKE CHANGES WITHOUT NOTICE TO ANY PRODUCTS HEREIN TO IMPROVE RELIABILITY, FUNCTION, OR DESIGN. FAIRCHILD DOES NOT ASSUME ANY LIABILITY ARISING OUT OF THE APPLICATION OR USE OF ANY PRODUCT OR CIRCUIT DESCRIBED HEREIN; NEITHER DOES IT CONVEY ANY LICENSE UNDER ITS PATENT RIGHTS, NOR THE RIGHTS OF OTHERS. THESE SPECIFICATIONS DO NOT EXPAND THE TERMS OF FAIRCHILD'S WORLDWIDE TERMS AND CONDITIONS, SPECIFICALLY THE WARRANTY THEREIN, WHICH COVERS THESE PRODUCTS.

**LIFE SUPPORT POLICY**

FAIRCHILD'S PRODUCTS ARE NOT AUTHORIZED FOR USE AS CRITICAL COMPONENTS IN LIFE SUPPORT DEVICES OR SYSTEMS WITHOUT THE EXPRESS WRITTEN APPROVAL OF FAIRCHILD SEMICONDUCTOR CORPORATION.

As used herein:

- Life support devices or systems are devices or systems which, (a) are intended for surgical implant into the body or (b) support or sustain life, and (c) whose failure to perform when properly used in accordance with instructions for use provided in the labeling, can be reasonably expected to result in a significant injury to the user.
- A critical component in any component of a life support, device or system whose failure to perform can be reasonably expected to cause the failure of the life support device or system, or to affect its safety or effectiveness.

**PRODUCT STATUS DEFINITIONS**

**Definition of Terms**

Datasheet Identification	Product Status	Definition
Advance Information	Formative or In Design	This datasheet contains the design specifications for product development. Specifications may change in any manner without notice.
Preliminary	First Production	This datasheet contains preliminary data; supplementary data will be published at a later date. Fairchild Semiconductor reserves the right to make changes at any time without notice to improve design.
No Identification Needed	Full Production	This datasheet contains final specifications. Fairchild Semiconductor reserves the right to make changes at any time without notice to improve design.
Obsolete	Not In Production	This datasheet contains specifications on a product that has been discontinued by Fairchild Semiconductor. The datasheet is printed for reference information only.

Rev. I33