

SIL Series

Hi-Voltage Reed Relay

Features

- Insulation coil to contact up to 4KVDC.
- High Dielectric Strength up to 4KVDC or Higher.
- Internal magnetic shield on all relays.



Order Code

SIL- 1A**XX** D **X**
 a b c d

a : Contact Form : 1=1FormA
 b : Nominal Coil Voltage : 05=5VDC, 12=12VDC, 24=24VDC
 c : Nil=NO Diode, D=Diode
 d : Nil:standard, H:High Voltage, U: Ultra High Voltage

Coil Data-Standard Type1 Form A (at 20°C)

Nominal Voltage DC \pm 10% [V]	Coil Resistance \pm 10% [ohm]	Nominal Coil power [mW]	Must Release Voltage MIN. [V] at 20°C	Must Operate Voltage MAX. [V] at 20°C
05	220	114	0.5	3.75
12	500	288	1.2	9.0
24	2000	288	2.4	16.8

Contact Rating

Relay Model	SIL-1A XX	SIL-1A XX H	SIL-1A XX U
Contact Rating	100 W	100 W	100 W
Switching Voltage	300VAC / 350VDC	1000 VDC	1000 VDC
Max. Switching Current	1.0 A	1.0 A	1.0 A
Max. Carry Current	2.5 A	2.5 A	2.5 A





Specification

Relay Model		SIL-1AXX	SIL-1AXXH	SIL-1AXXU
Contact Resistance		150mΩ	150mΩ	150mΩ
Dynamic Contact Resistance		200mΩ	200mΩ	200mΩ
Breakdown Voltage	Contacts to Coil	4KVDC	4KVDC	4KVDC
	Open Contacts	3KVDC	3KVDC	4KVDC
Insulation Resistance	Open Contacts	1*10 ¹⁰ Ω	1*10 ¹³ Ω	1*10 ¹³ Ω
	Contacts to Coil	1*10 ¹⁰ Ω	1*10 ¹² Ω	1*10 ¹² Ω
Capacitance (typ.) Open contacts		0.5 pF	0.2 pF	0.2 pF
Operate Time		0.6 ms	1.0 ms	1.0 ms
Release Time		0.25 ms	0.25 ms	0.25 ms
Vibration		20G 10-2000Hz	20G 10-2000Hz	20G 10-2000Hz
Shock		30G	50G	50G
Operating Temperature		-40°C ~ +85°C	-40°C ~ +85°C	-40°C ~ +85°C
Storage Temperature		-40°C ~ +95°C	-40°C ~ +95°C	-40°C ~ +95°C
Life Expectancy		1KVDC, 1mA, 1*10 ⁶	5V, 10mA, 5*10 ⁸	5V, 10mA, 5*10 ⁸

Dimensions (Unit : mm)

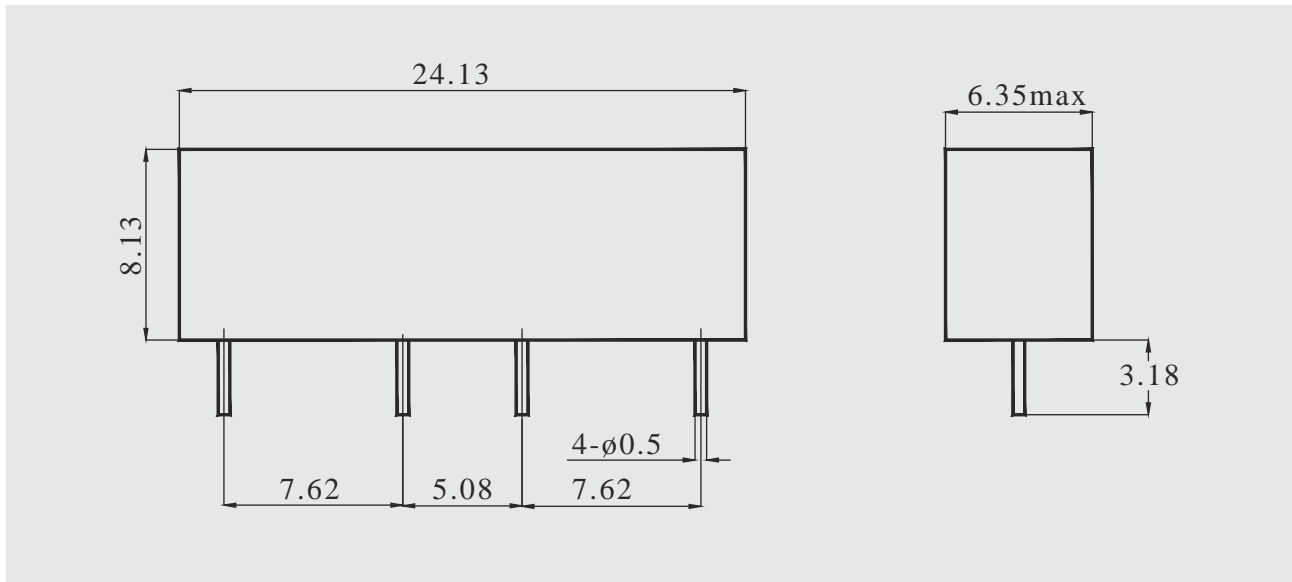

Wiring Diagrams (Top View)

