



LITE-ON TECHNOLOGY CORPORATION

Property of Lite-On Only

FEATURES

- * TTL INTERFACE COMPATIBLE
- * HIGH SPEED OPTIC SIGNAL TRANSMISSION
- * BUILT-IN LED DRIVER
- * LOW POWER CONSUMPTION

* V_{DD}	V_{in}	LED	V_{DD}	V_{in}	LED
2.7V ~ 5.25V	HIGH	ON	FLOATING	HIGH	OFF
2.7V ~ 5.25V	LOW	OFF	FLOATING	LOW	OFF
2.7V ~ 5.25V	FLOATING	OFF			

- * WATER CLEAR EPOXY COMPOUND PACKAGED.

PACKAGE DIMENSIONS

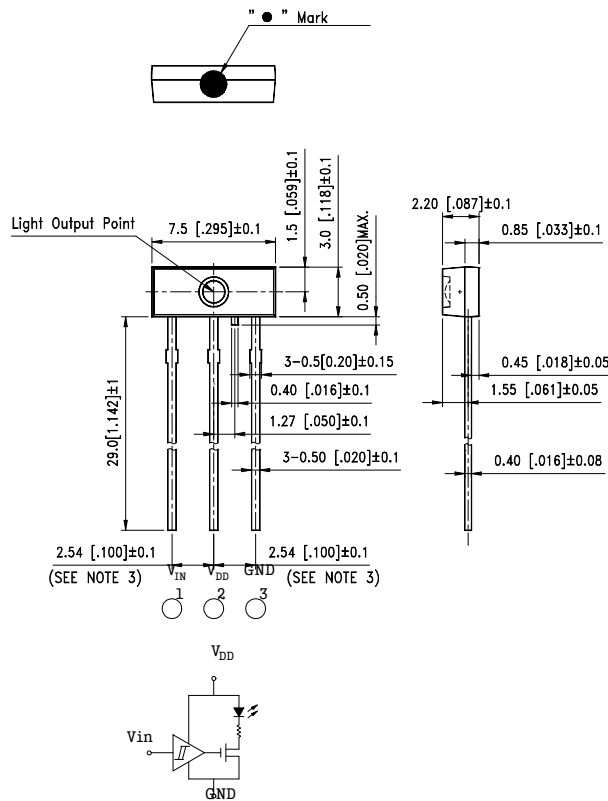

NOTES:

1. All dimensions are in millimeters (inches).
2. Tolerance is $\pm 0.1\text{mm}$ (.004") unless otherwise noted.
3. Lead spacing is measured where the leads emerge from the package.
4. Mark color: Black.



LITE-ON TECHNOLOGY CORPORATION

Property of Lite-On Only

ABSOLUTE MAXIMUM RATINGS AT TA=25°C

PARAMETER	MAXIMUM RATING	UNIT
Supply Voltage (V _{DD})	-0.5 ~ +7	V
Input Voltage (V _{IN})	-0.5 ~ V _{DD} +0.5	V
Power Dissipation (P)	120	mW
Operating Temperature Range	-25 °C to + 70 °C	
Storage Temperature Range	-40 °C to + 70 °C	
Lead Soldering Temperature [1.6mm(.063") From Body]	260°C ≤ 5 Seconds	

ELECTRICAL OPTICAL CHARACTERISTICS AT TA=25°C

PARAMETER	SYMBOL	MIN.	TYP.	MAX.	UNIT	TEST CONDITION
Transmission Speed	T _s	—	—	16	Mbps	NRZ signal
Operating Voltage	V _{DD}	2.75	—	5.25	V	
Peak Emission Wavelength	λ _{Peak}	630	650	690	nm	
Fiber coupling light output	P _c	-21	-17	-15	dBm	*1
Dissipation current	I _{DD}	—	5	11	mA	*2
High level input voltage	V _{IH}	2	—	—	V	
Low level input voltage	V _{IL}	—	—	0.8	V	
“Low→High”propagation delay time	t _{PLH}	—	—	100	ns	*3
“High→Low”propagation delay time	t _{PHL}	—	—	100	ns	
Pulse width distortion	Δt _w	-20	—	20	ns	
Jitter	Δt _j	—	—	10	ns	

***1 Measuring method of optical output coupling power**

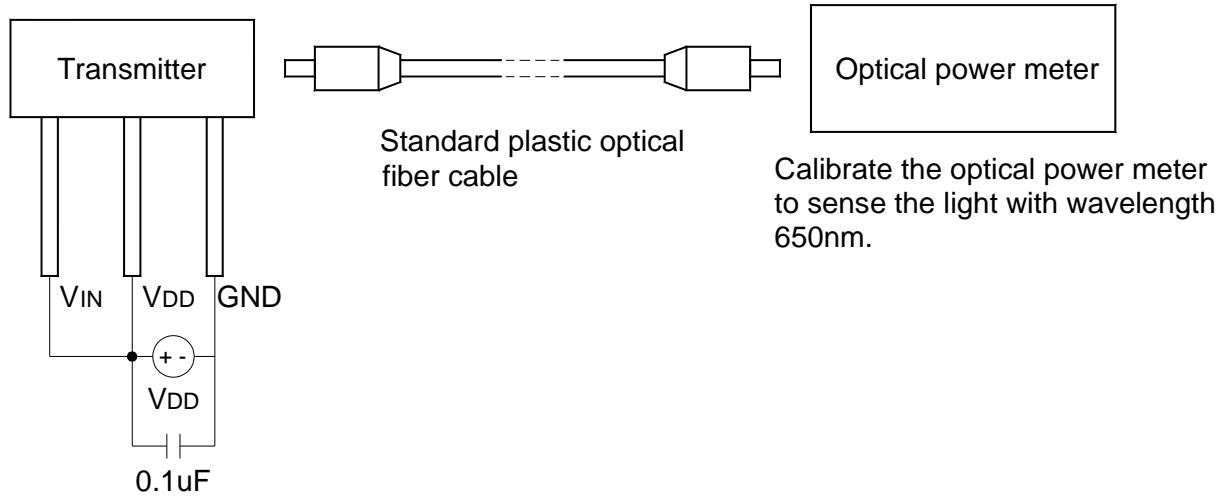

***2 Power dissipation measuring method**

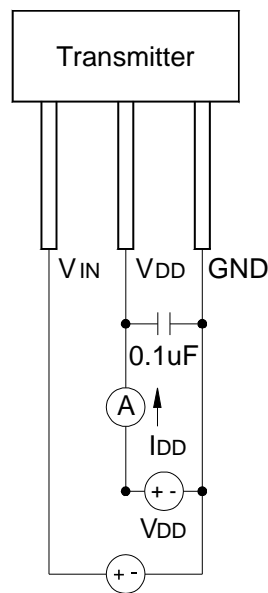

***3 Measuring pulse response**

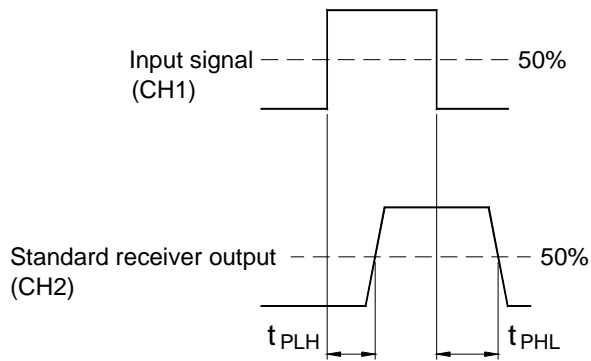
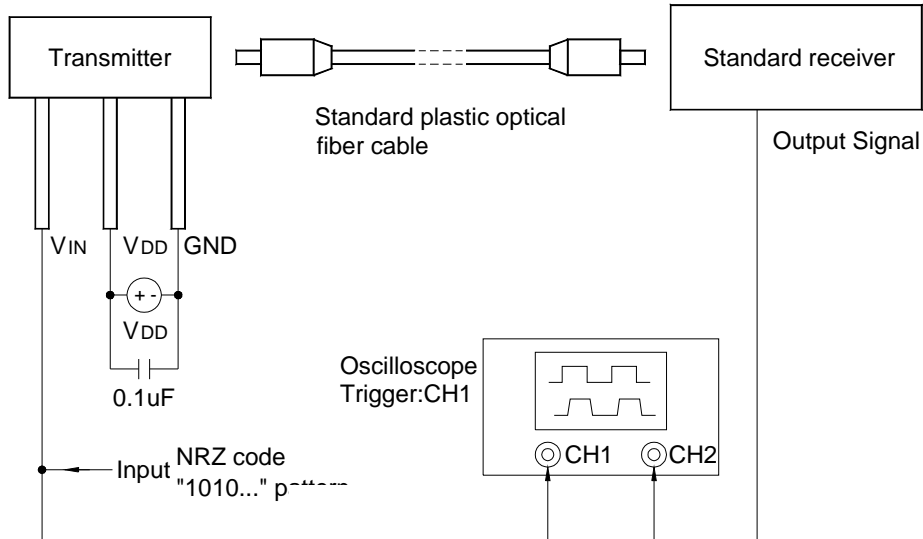

Pulse width distortion $\Delta tw = t_{PHL} - t_{PLH}$

Note

- (1) NRZ code: 16MHz
- (2) The impedance of the probe for the oscilloscope must be more than 1MΩ and less than 10pf.