

# OSRAM LZ1-00UBN0

## Datasheet

Published by **ams-OSRAM AG**

Tobelbader Strasse 30, 8141 Premstaetten, Austria

Phone +43 3136 500-0

[ams-osram.com](http://ams-osram.com)

© All rights reserved



## LED ENGIN LuxiGen

# LZ1-00UBN0

Industry most robust high power ceramic package with glass lens for high performance over life.



### Applications

- Electronic Equipment
- Equipment Illumination (e.g. Curing, Endoscope)
- Gaming, Amusement, Gambling
- Horticulture Lighting
- Industrial Automation (Machine Controls, Light Barriers, Vision Controls)
- Photo Therapy
- Smoke/Dust/Particle Sensing
- Stage Lighting (LED & Laser)

### Features

- Package: Ceramic package with integrated glass lens
- Chip technology: UX:3
- Typ. Radiation: 60°
- Color:  $\lambda_{\text{peak}} = 395 \text{ nm}$  (• violet)

## Ordering Information

Type	Total radiant flux <sup>1)</sup> $I_F = 700 \text{ mA}$ $\Phi_E$	Ordering Code
LZ1-00UBN0-00U4	1100 ... 2000 mW	Q65113A4143
LZ1-00UBN0-00U5	1100 ... 2000 mW	Q65113A4142
LZ1-00UBN0-00U8	1100 ... 2000 mW	Q65113A4141

## Maximum Ratings

Parameter	Symbol	Values
Operating Temperature	$T_{op}$	min. -30 °C max. 100 °C
Storage Temperature	$T_{stg}$	min. -40 °C max. 125 °C
Junction Temperature <sup>2)</sup>	$T_j$	max. 115 °C
Forward Current <sup>2)</sup>	$I_F$	max. 700 mA
Forward Current pulsed $t \leq 10 \text{ ms}$ ; $D \leq 0.1$ ; $T_c = 25 \text{ °C}$	$I_{F \text{ pulse}}$	max. 700 mA
ESD withstand voltage acc. ANSI/ESDA/JEDEC JS-001 (HBM, Class 0)	$V_{ESD}$	ESD sensitive device
Reverse voltage <sup>3)</sup>	$V_R$	Not designed for reverse operation

## Characteristics

$I_F = 700 \text{ mA}$ ;  $T_C = 25 \text{ °C}$

Parameter	Symbol		Values
Total radiant flux <sup>4)</sup>	$\Phi_E$	typ.	1450 mW
Peak Wavelength <sup>5)</sup> $I_F = 700 \text{ mA}$	$\lambda_{\text{peak}}$	min. typ. max.	385 nm 395 nm 410 nm
Viewing angle at 50% $I_v$	$2\varphi$	typ.	70 °
Forward Voltage <sup>6)4)</sup> $I_F = 700 \text{ mA}$	$V_F$	min. typ. max.	3.20 V 3.70 V 4.20 V
Reverse current <sup>3)</sup>	$I_R$		Not designed for reverse operation
Electrical thermal resistance junction/case	$R_{\text{thJC elec.}}$	typ.	2.0 K / W

## Brightness Groups

Group	Total radiant flux <sup>1)</sup> $I_F = 700 \text{ mA}$ min. $\Phi_E$	Total radiant flux <sup>1)</sup> $I_F = 700 \text{ mA}$ max. $\Phi_E$
M1	1100 mW	1375 mW
N1	1375 mW	1760 mW
P1	1760 mW	2000 mW

## Wavelength Groups

Group	Peak Wavelength <sup>5)</sup> $I_F = 700 \text{ mA}$ min. $\lambda_{\text{peak}}$	Peak Wavelength <sup>5)</sup> $I_F = 700 \text{ mA}$ max. $\lambda_{\text{peak}}$
U4	385 nm	390 nm
U5	390 nm	395 nm
U8	405 nm	410 nm

## Group Name on Label

### Example: M1-U4

Brightness	Wavelength
M1	U4

### Relative Spectral Emission <sup>4)</sup>

$I_{rel} = f(\lambda)$ ;  $I_F = 700 \text{ mA}$ ;  $T_C = 25 \text{ }^\circ\text{C}$

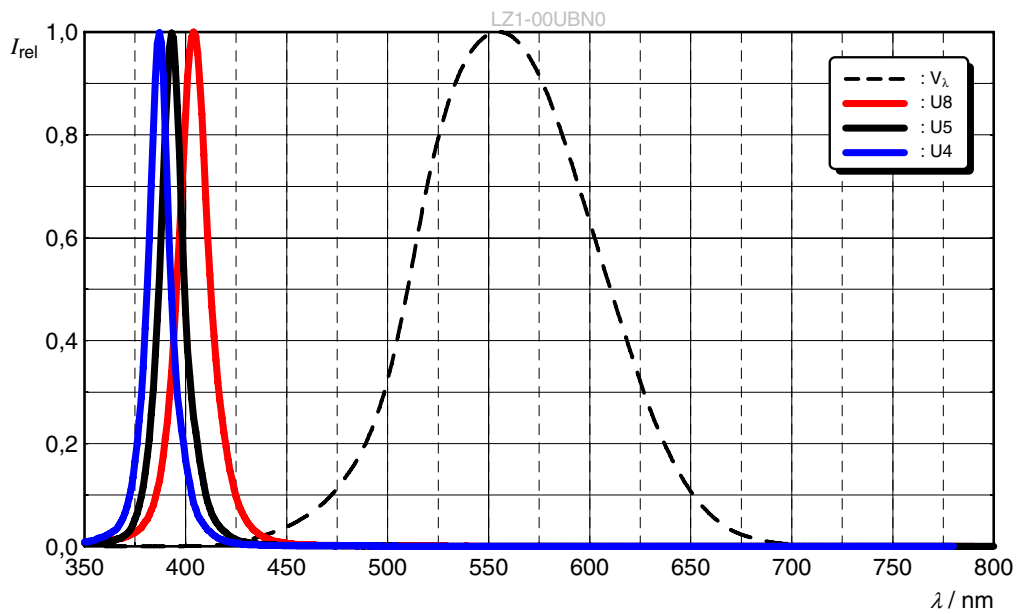

### Radiation Characteristics <sup>4)</sup>

$I_{rel} = f(\phi)$ ;  $T_C = 25 \text{ }^\circ\text{C}$

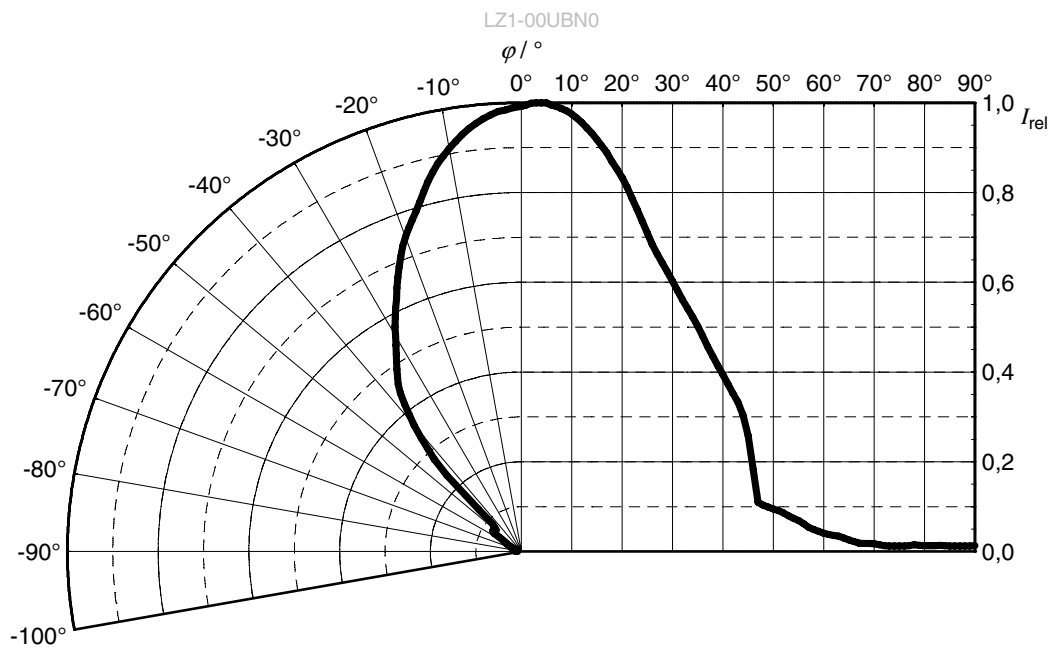

### Forward current <sup>4)</sup>

$$I_F = f(V_F); T_C = 25\text{ °C}$$

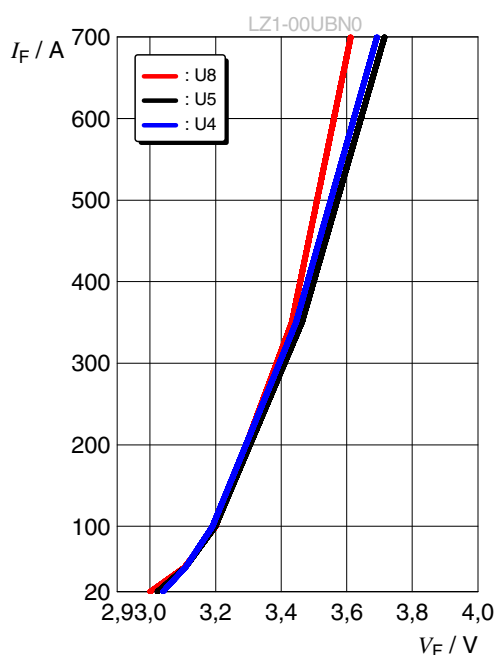

### Relative Radiant Power <sup>4), 7)</sup>

$$\Phi_E / \Phi_E(700\text{ mA}) = f(I_F); T_C = 25\text{ °C}$$

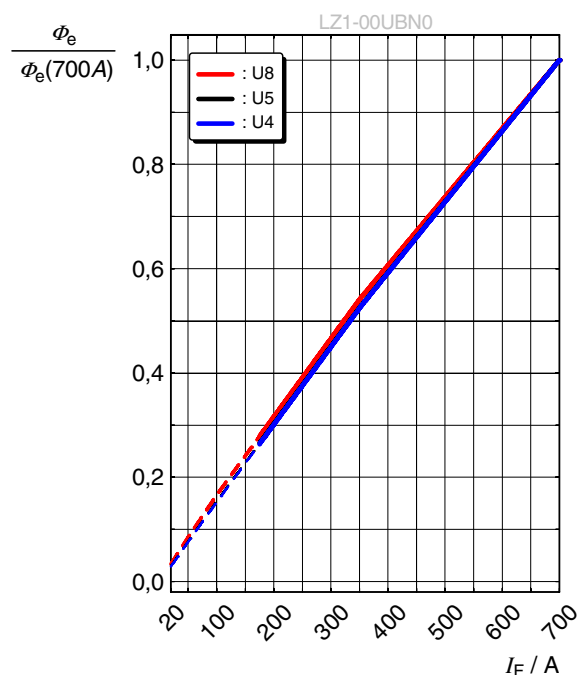

### Peak Wavelength <sup>4)</sup>

$$\Delta\lambda_{\text{peak}} = \lambda_{\text{peak}} - \lambda_{\text{peak}}(25\text{ °C}) = f(T_j); I_F = 700\text{ mA}$$

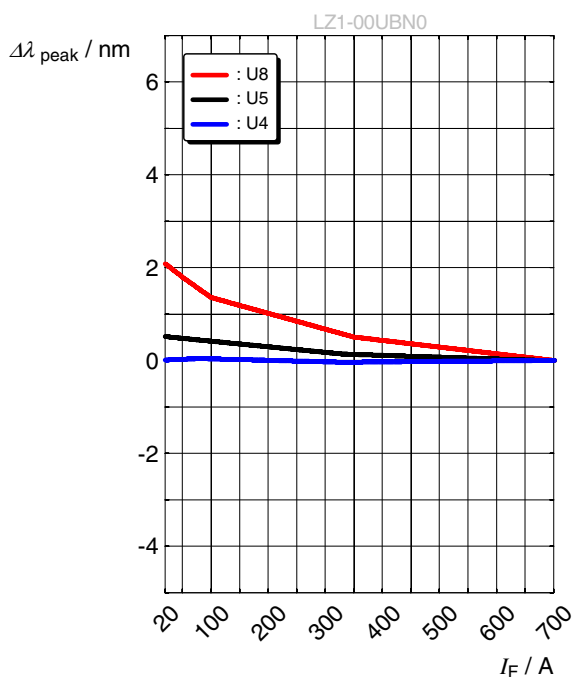



### Forward Voltage <sup>4)</sup>

$$\Delta V_F = V_F - V_F(25\text{ °C}) = f(T_j); I_F = 700\text{ mA}$$

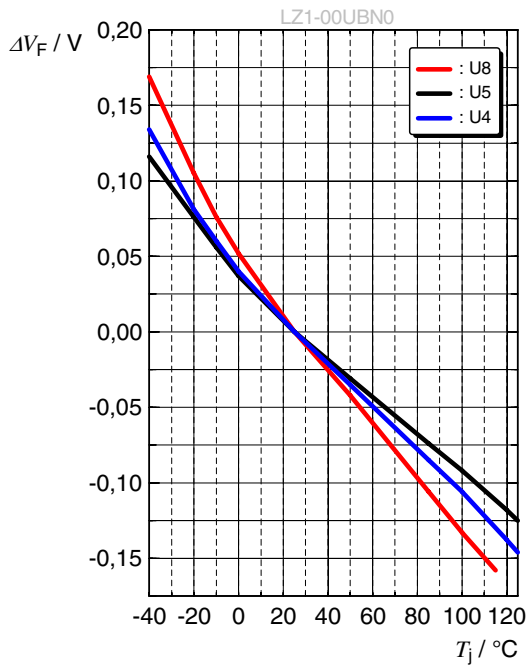

### Relative Radiant Power <sup>4)</sup>

$$\Phi_E / \Phi_E(25\text{ °C}) = f(T_j); I_F = 700\text{ mA}$$

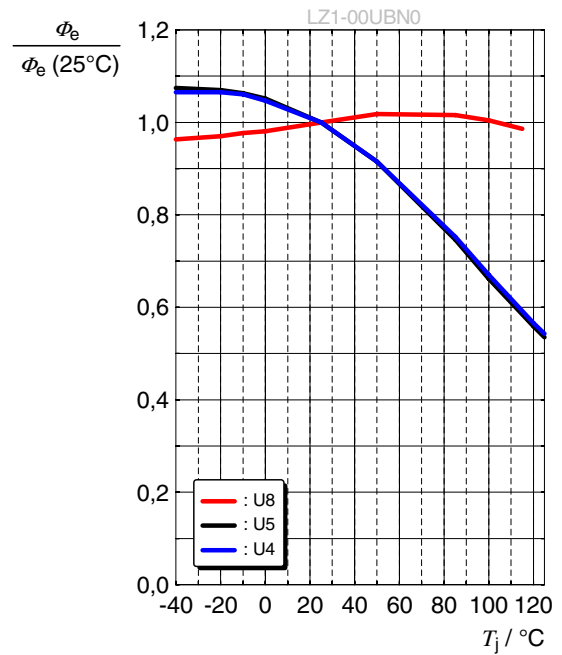

### Peak Wavelength <sup>4)</sup>

$$\Delta \lambda_{\text{peak}} = \lambda_{\text{peak}} - \lambda_{\text{peak}}(25\text{ °C}) = f(T_j); I_F = 700\text{ mA}$$

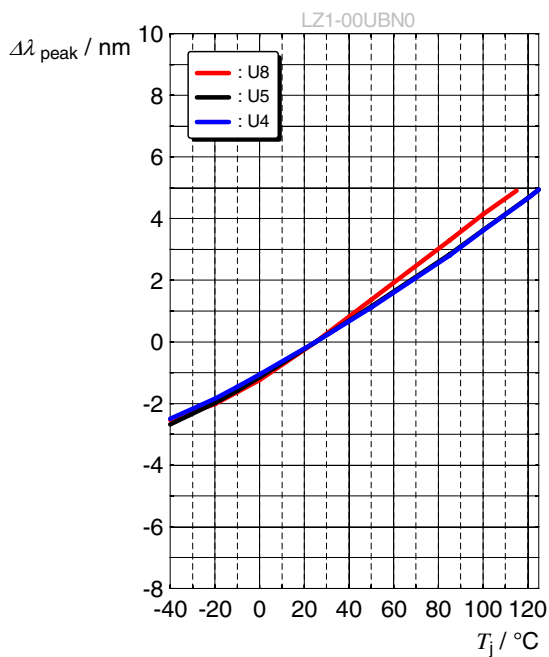

### Max. Permissible Forward Current

$$I_F = f(T)$$

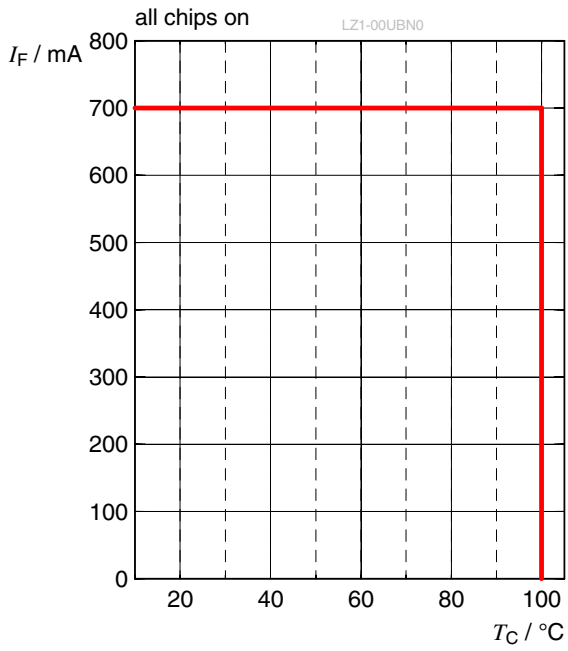

Dimensional Drawing <sup>8)</sup>

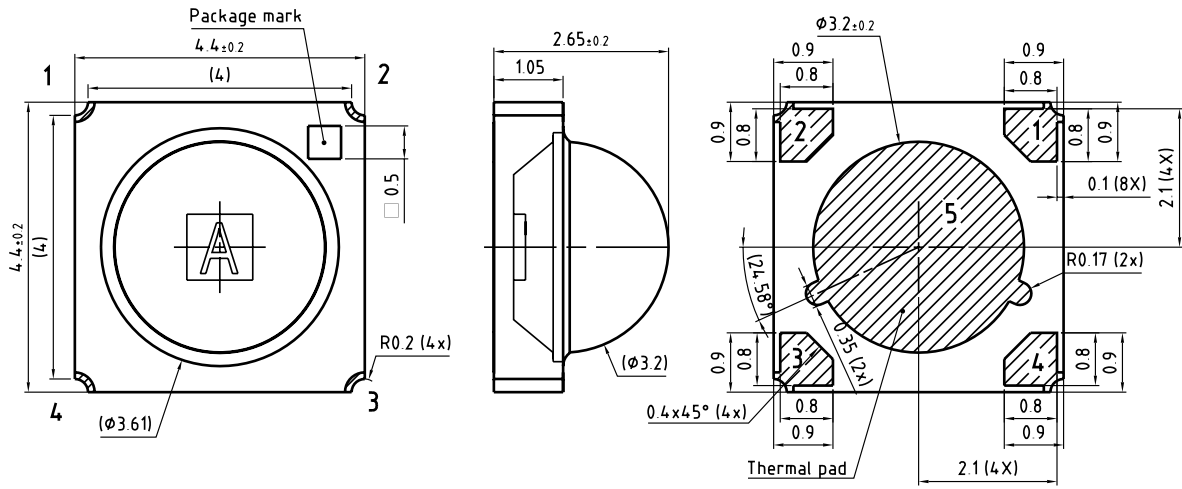

General tolerance  $\pm 0.1$

Pad finish silver 

C67062-A0371-A1-01

Further Information:

Approximate Weight: 93.9 mg

### Electrical Internal Circuit

Pin Out	
Pad	Function
1	Cathode
2	Anode
3	Anode
4	Cathode
5	Thermal

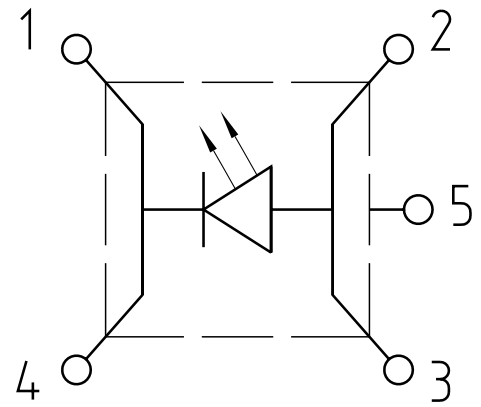

Recommended Solder Pad <sup>8)</sup>

Non-pedestal MCPCB Design

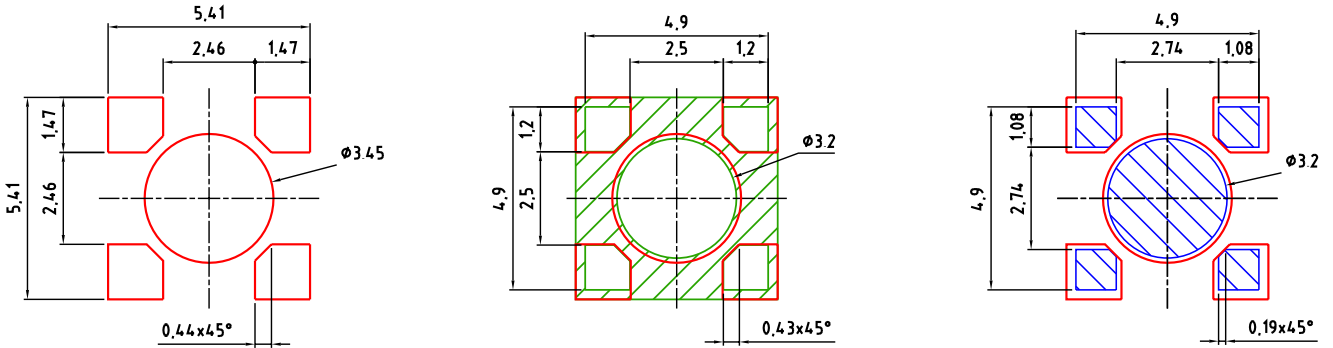

Pedestal MCPCB Design

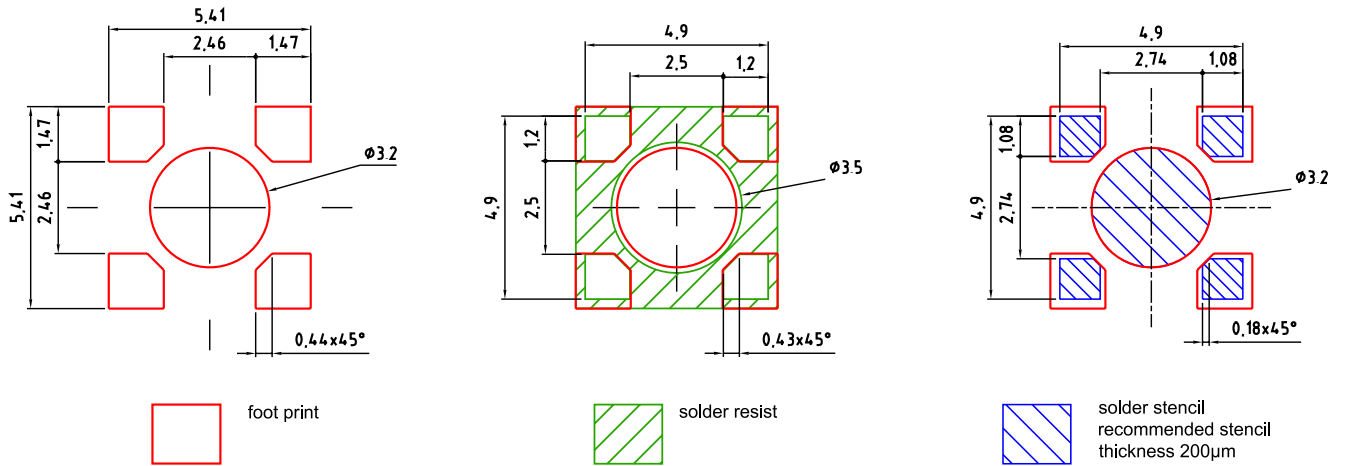

Component Location on Pad

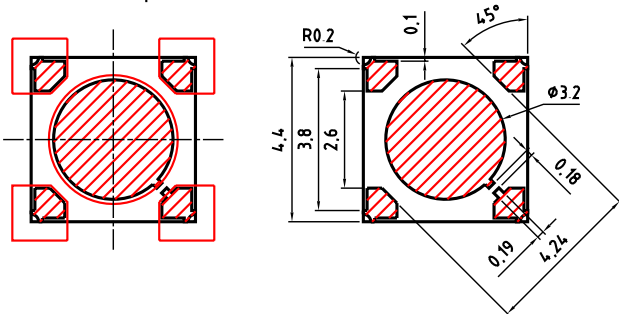

E062.3010.296-01

1. For superior solder joint connectivity results we recommend soldering under standard nitrogen atmosphere.
2. Package not suitable for ultra sonic cleaning.
3. Pedestal MCPCB allows the emitter thermal slug to be soldered directly to the metal core of the MCPCB. Such MCPCB eliminate the high thermal resistance dielectric layer that standard MCPCB technologies use in between the emitter thermal slug and the metal core of the MCPCB, thus lowering the overall system thermal resistance.
4. X-ray sample monitoring for solder voids underneath the emitter thermal slug is recommended. The total area covered by solder voids should be less than 20% of the total emitter thermal slug area. Excessive solder voids will increase the emitter to MCPCB thermal resistance and may lead to higher failure rates due to thermal over stress.

### Reflow Soldering Profile

Product complies to MSL Level 1 acc. to JEDEC J-STD-020E

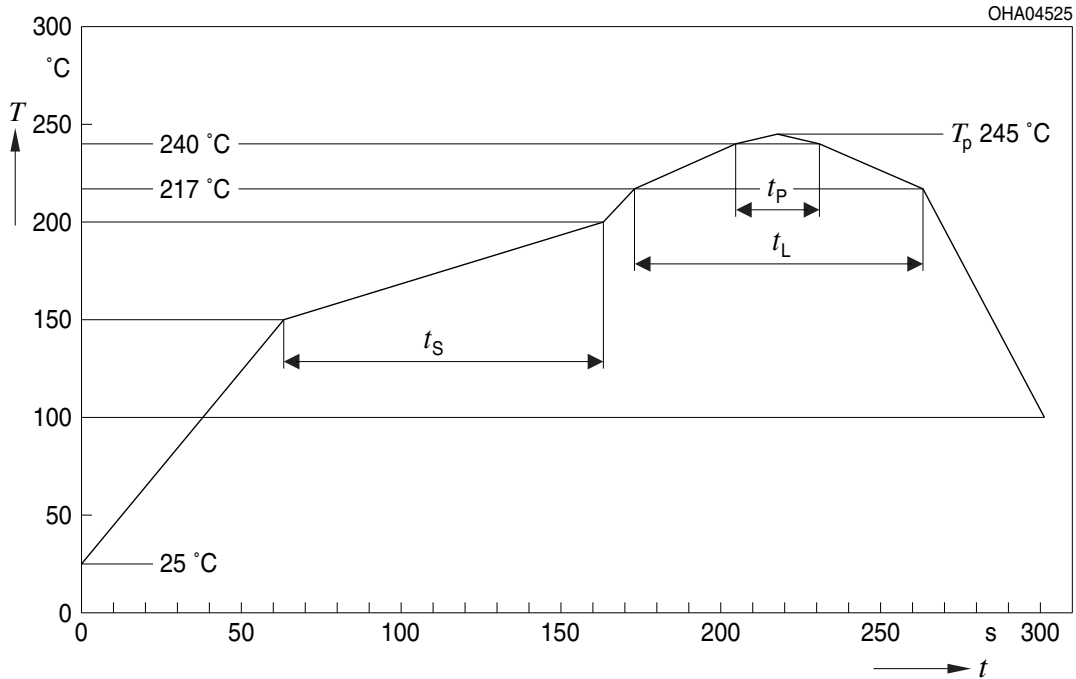

Profile Feature	Symbol	Pb-Free (SnAgCu) Assembly			Unit
		Minimum	Recommendation	Maximum	
Ramp-up rate to preheat <sup>*)</sup> 25 °C to 150 °C			2	3	K/s
Time $t_s$ $T_{Smin}$ to $T_{Smax}$	$t_s$	60	100	120	s
Ramp-up rate to peak <sup>*)</sup> $T_{Smax}$ to $T_p$			2	3	K/s
Liquidus temperature	$T_L$		217		°C
Time above liquidus temperature	$t_L$		80	100	s
Peak temperature	$T_p$		245	250	°C
Time within 5 °C of the specified peak temperature $T_p - 5$ K	$t_p$	10	20	30	s
Ramp-down rate* $T_p$ to 100 °C			3	4	K/s
Time 25 °C to $T_p$				480	s

All temperatures refer to the center of the package, measured on the top of the component  
<sup>\*</sup> slope calculation  $DT/Dt$ :  $Dt$  max. 5 s; fulfillment for the whole T-range

Taping <sup>8)</sup>

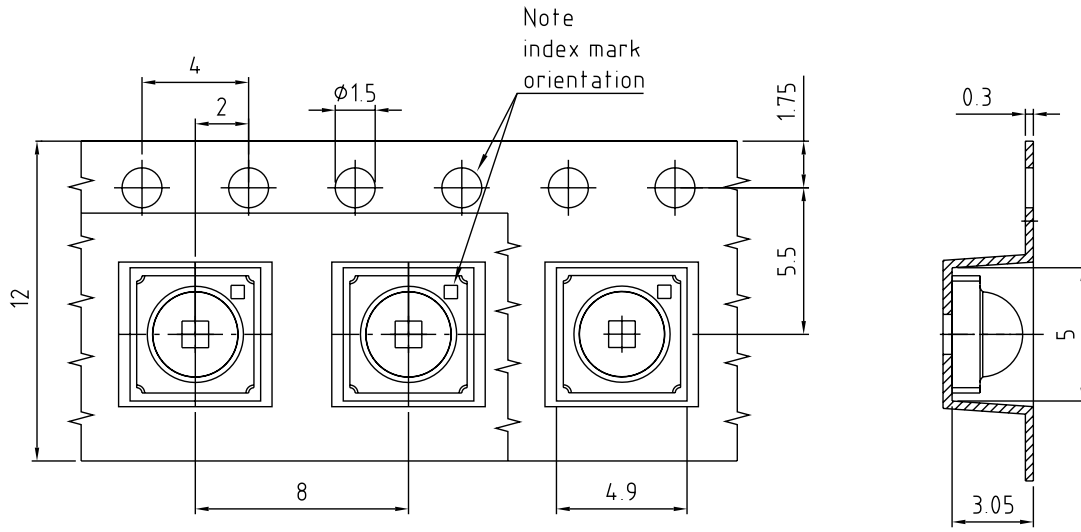

C67062-A0371-B1-01

Tape and Reel <sup>9)</sup>

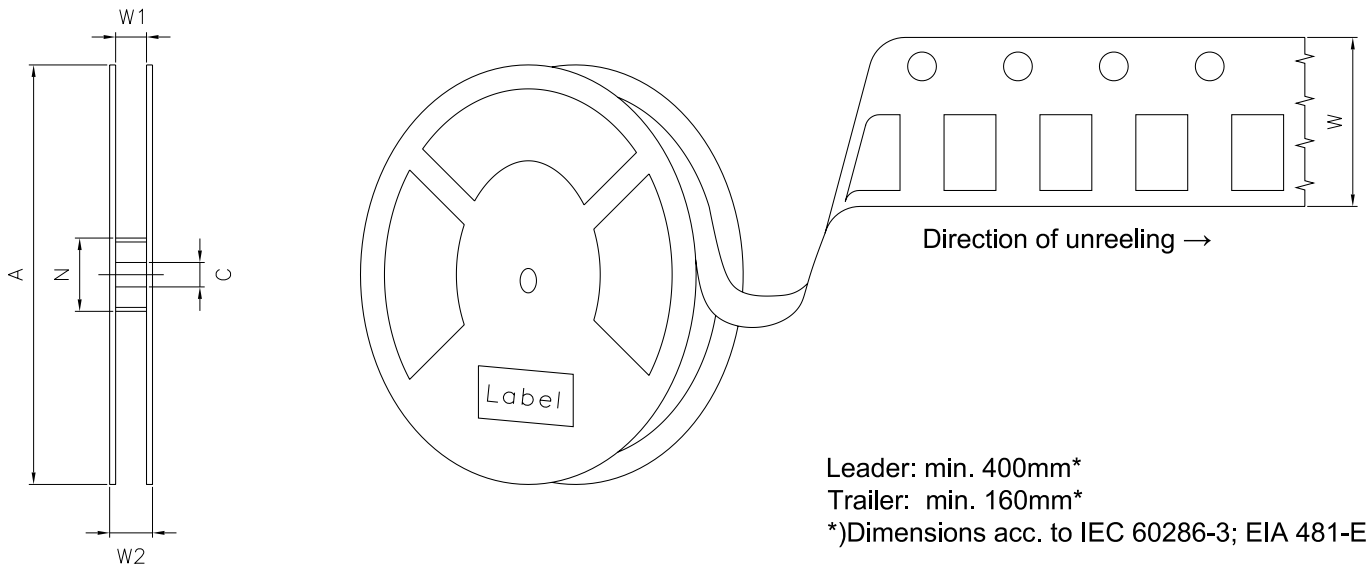

Reel Dimensions

A	W	N <sub>min</sub>	W <sub>1</sub>	W <sub>2max</sub>	Pieces per PU
180 mm	12 + 0.3 / - 0.1 mm	60 mm	12.4 + 2 mm	18.4 mm	500



**Barcode-Product-Label (BPL)**

**OSRAM**  
Opto Semiconductors  
Our Brand   
**LED ENGINE**

(6P) Batch No: 1234567890  
(1T) Lot No: 1234567890  
(X) Prod No: 12345678  
(9D) D/C : 1234  
(Q) Qty: 9999  
CoO: XX

LXX-XXXXX  
XxxXxx  
RoHS Compliant

BIN1: XXX-X-X-XXX  
BIN2: XXX-X-X-XXX  
BIN3: XX-X-X-XXX  
BIN4: XXX-XXX-X-XXX  
BIN5: X-XX-X-XXX  
BIN6: X-XX-X-XXX

ML TEMP ST  
X XXX° X

Pack: RXX  
B\_X123\_12345.1234  
001

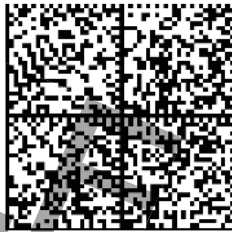

---

## Notes

The evaluation of eye safety occurs according to the standard IEC 62471:2006 (photo biological safety of lamps and lamp systems). Within the risk grouping system of this IEC standard, the device specified in this data sheet fall into the class **high risk (exposure time less than 0.25 s)**. Under real circumstances (for exposure time, conditions of the eye pupils, observation distance), it is assumed that no endangerment to the eye exists from these devices. As a matter of principle, however, it should be mentioned that intense light sources have a high secondary exposure potential due to their blinding effect. When looking at bright light sources (e.g. headlights), temporary reduction in visual acuity and afterimages can occur, leading to irritation, annoyance, visual impairment, and even accidents, depending on the situation.

Subcomponents of this device contain, in addition to other substances, metal filled materials including silver. Metal filled materials can be affected by environments that contain traces of aggressive substances. Therefore, we recommend that customers minimize device exposure to aggressive substances during storage, production, and use. Devices that showed visible discoloration when tested using the described tests above did show no performance deviations within failure limits during the stated test duration. Respective failure limits are described in the IEC60810.

Tapes and reels are shipped in airtight bags in order to reduce the onset of silver tarnish. We recommend bags only be opened when ready to use emitters. Partially used reels or trays should be stored in airtight bags or in storage purged with nitrogen.

Based on very short life cycle times in chip technology this component is subject to frequent adaption to the latest chip technology.

Changes to the content of this datasheet may occur without further notification. JEDEC 46C constitutes the guideline of the change management for the device specified in this document.

For further application related information please visit [www.osram-os.com/appnotes](http://www.osram-os.com/appnotes)

## Disclaimer

### Attention please!

The information describes the type of component and shall not be considered as assured characteristics. Terms of delivery and rights to change design reserved. Due to technical requirements components may contain dangerous substances.

For information on the types in question please contact our Sales Organization.

If printed or downloaded, please find the latest version on our website.

### Packing

Please use the recycling operators known to you. We can also help you – get in touch with your nearest sales office. By agreement we will take packing material back, if it is sorted. You must bear the costs of transport. For packing material that is returned to us unsorted or which we are not obliged to accept, we shall have to invoice you for any costs incurred.

### Product and functional safety devices/applications or medical devices/applications

Our components are not developed, constructed or tested for the application as safety relevant component or for the application in medical devices.

Our products are not qualified at module and system level for such application.

In case buyer – or customer supplied by buyer – considers using our components in product safety devices/ applications or medical devices/applications, buyer and/or customer has to inform our local sales partner immediately and we and buyer and /or customer will analyze and coordinate the customer-specific request between us and buyer and/or customer.

---

## Glossary

- 1) **Brightness:** Brightness groups are tested at a current pulse duration of 10 ms and a tolerance of  $\pm 10\%$ .
- 2) **Operating Conditions:** Operating conditions according DC-derating (Max. Permissible Forward Current)
- 3) **Reverse Operation:** Not designed for reverse operation. Continuous reverse operation can cause migration and damage of the device.
- 4) **Typical Values:** Due to the special conditions of the manufacturing processes of semiconductor devices, the typical data or calculated correlations of technical parameters can only reflect statistical figures. These do not necessarily correspond to the actual parameters of each single product, which could differ from the typical data and calculated correlations or the typical characteristic line. If requested, e.g. because of technical improvements, these typ. data will be changed without any further notice.
- 5) **Peak Wavelength:** Wavelengths are tested at a current pulse duration of 10 ms and a tolerance of  $\pm 2$  nm.
- 6) **Forward Voltage:** Forward voltages are tested at a current pulse duration of 10 ms and a tolerance of  $\pm 0.1$  V.
- 7) **Characteristic curve:** In the range where the line of the graph is broken, you must expect higher differences between single devices within one packing unit.
- 8) **Tolerance of Measure:** Unless otherwise noted in drawing, tolerances are specified with  $\pm 0.1$  and dimensions are specified in mm.
- 9) **Tape and Reel:** All dimensions and tolerances are specified acc. IEC 60286-3 and specified in mm.

---

## Revision History

Version	Date	Change
1.0	2022-06-25	Electro - Optical Characteristics (Diagrams) New Layout Derating (Diagrams) Maximum Ratings

---



EU RoHS and China RoHS compliant product

此产品符合欧盟 RoHS 指令的要求；  
按照中国的相关法规和标准，  
不含有毒有害物质或元素。

**Published by ams-OSRAM AG**

Tobelbader Strasse 30, 8141 Premstaetten, Austria

Phone +43 3136 500-0

[ams-osram.com](http://ams-osram.com)

© All rights reserved

**am** 

**OSRAM**