

NCS36000

Passive Infrared (PIR) Detector Controller

The NCS36000 is a fully integrated mixed-signal CMOS device designed for low-cost passive infrared controlling applications. The device integrates two low-noise amplifiers and a LDO regulator to drive the sensor. The output of the amplifiers goes to a window comparator that uses internal voltage references from the regulator. The digital control circuit processes the output from the window comparator and provides the output to the OUT and LED pin.

Features

- 3.0 – 5.75 V Operation
- –40 to 85°C
- 14 Pin SOIC Package
- Integrated 2-Stage Amplifier
- Internal LDO to Drive Sensor
- Internal Oscillator with External RC
- Single or Dual Pulse Detection
- Direct Drive of LED and OUT
- This is a Pb-Free Device

Typical Applications

- Automatic Lighting (Residential and Commercial)
- Automation of Doors
- Motion Triggered Events (Animal photography)

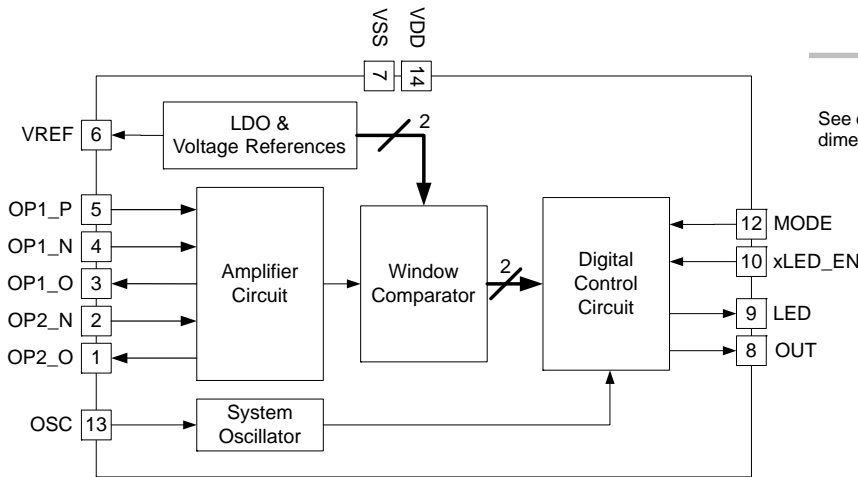

Figure 1. Simplified Block Diagram



ON Semiconductor®

www.onsemi.com

MARKING DIAGRAM

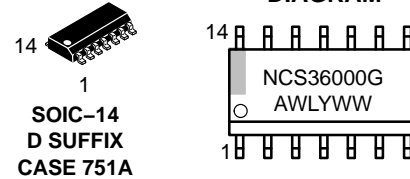

- A = Assembly Location
- WL = Wafer Lot
- Y = Year
- WW = Work Week
- G = Pb-Free Package

PIN CONNECTIONS

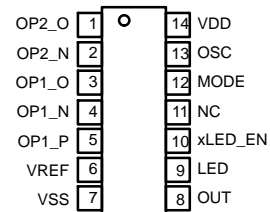

(Top View)

ORDERING INFORMATION

See detailed ordering and shipping information in the package dimensions section on page 7 of this data sheet.

NCS36000

PIN FUNCTION DESCRIPTION

Pin No.	Pin Name	Description
1	OP2_O	Output of second amplifier
2	OP2_N	Inverting input of second amplifier
3	OP1_O	Output of first amplifier
4	OP1_N	Inverting input of first amplifier
5	OP1_P	Non-inverting input of first amplifier
6	VREF	Regulated voltage reference to drive sensor
7	VSS	Analog ground reference.
8	OUT	CMOS output (10 mA Max)
9	LED	CMOS output to drive LED (10mA Max)
10	xLED_EN	Active low LED enable input
11	NC	No Connect
12	MODE	Pin used to select pulse count mode
13	OSC	External oscillator to control clock frequency
14	VDD	Analog power supply

ABSOLUTE MAXIMUM RATINGS

Rating	Symbol	Value	Unit
Input Voltage Range (Note 1)	V_{in}	-0.3 to 6.0	V
Output Voltage Range	V_{out}	-0.3 to 6.0 V or ($V_{in} + 0.3$), whichever is lower	V
Maximum Junction Temperature	$T_{J(max)}$	140	°C
Storage Temperature Range	T_{STG}	-65 to 150	°C
ESD Capability, Human Body Model (Note 2)	ESD _{HBM}	2	kV
ESD Capability, Machine Model (Note 2)	ESD _{MM}	200	V
Lead Temperature Soldering Reflow (SMD Styles Only), Pb-Free Versions (Note 3)	T_{SLD}	260	°C

Stresses exceeding those listed in the Maximum Ratings table may damage the device. If any of these limits are exceeded, device functionality should not be assumed, damage may occur and reliability may be affected.

1. Refer to ELECTRICAL CHARACTERISTICS and APPLICATION INFORMATION for Safe Operating Area.
2. This device series incorporates ESD protection and is tested by the following methods:
ESD Human Body Model tested per AEC-Q100-002 (EIA/JESD22-A114)
ESD Machine Model tested per AEC-Q100-003 (EIA/JESD22-A115)
Latchup Current Maximum Rating: ≤ 150 mA per JEDEC standard: JESD78
3. For information, please refer to our Soldering and Mounting Techniques Reference Manual, SOLDERRM/D

THERMAL CHARACTERISTICS

Rating	Symbol	Value	Unit
Thermal Characteristics, DFN6, 3x3.3 mm (Note 4) Thermal Resistance, Junction-to-Air (Note 5) Thermal Reference, Junction-to-Lead2 (Note 5)	$R_{\theta JA}$ $R_{\psi JL}$	Will be Completed once package and power consumption is finalized	°C/W
Thermal Characteristics, TSOP-5 (Note 4) Thermal Resistance, Junction-to-Air (Note 5)	$R_{\theta JA}$	See note above.	°C/W

4. Refer to ELECTRICAL CHARACTERISTICS and APPLICATION INFORMATION for Safe Operating Area.
5. Values based on copper area of 645 mm² (or 1 in²) of 1 oz copper thickness and FR4 PCB substrate.

NCS36000

OPERATING RANGES (Note 6)

Rating		Symbol	Min	Typ	Max	Unit
Analog Power Supply		V_{DD}	3.0	5.0	5.75	V
Analog Ground Reference		V_{SS}		0.0	0.1	V
Supply Current (Standby, No Loads)		I_{DD}			170 μ	A
Digital Inputs (MODE)		V_{ih}	0.7 * V_{DD}	V_{DD}	$V_{DD} + 0.3$	V
		V_{il}	VSS		$V_{DD} * 0.28$	
Digital Output (OUT, LED)	Push-Pull Output (10 mA Load)	V_{oh}	0.67 * V_{DD}		V_{DD}	V
		V_{ol}	VSS		$V_{DD} * 0.3$	
OP1_P (Sensor Input) (Note 7)		AMP 1 IN	0.1		$V_{DD} - 1.1$	V
Ambient Temperature		T_A	-40		85	$^{\circ}$ C

6. Refer to ELECTRICAL CHARACTERISTICS and APPLICATION INFORMATION for Safe Operating Area.

7. Guaranteed By Design (Non-tested parameter).

ELECTRICAL CHARACTERISTICS $V_{in} = 1$ V, $C_{in} = 100$ nF, $C_{out} = 100$ nF, for typical values $T_A = 25^{\circ}$ C; unless otherwise noted.

Parameter	Test Conditions	Symbol	Min	Typ	Max	Unit
-----------	-----------------	--------	-----	-----	-----	------

LDO Voltage Reference

Output Voltage	$V_{DD} = 3.0$ V to 5.75 V	VREF	2.6	2.7	2.8	V
Supply Current	$V_{DD} = 3.0$ V to 5.75V	IREF		20	50	μ A
Comparator High Trip Level		V_h	2.413	2.5	2.588	V
Comparator Low Trip Level		V_l	1.641	1.7	1.760	V
Reference voltage for non-inverting input of second amplifier		V_m	2.007	2.1	2.174	V

System Oscillator

Oscillator Frequency	$V_{DD} = 5.0$ V $R_3 = 220$ k Ω $C_2 = 100$ nF	OSC		62.5		Hz
----------------------	--	-----	--	------	--	----

Window Comparator

Lower Trip Threshold	See V_l above					
Higher Trip Threshold	See V_h above					

Differential Amplifiers (Amplifier Circuit)

DC Gain	$V_{DD} = 5.0$ V (Note 8)	A_v	80			dB
Common-mode Input Range	$V_{DD} = 5.0$ V (Note 8)	CMIR	0.1		$V_{DD} - 1.1$	V
Power Supply Rejection Ratio	$V_{DD} = 5.0$ V (Note 8)	PSRR		60		dB
Output Drive Current	$V_{DD} = 5.0$ V (Note 8)	I_{out1}			25	μ A

POR

POR Release Voltage		V_{POR}	1.35		2.85	V
---------------------	--	-----------	------	--	------	---

8. Guaranteed By Design (Non-tested parameter).

APPLICATIONS INFORMATION

Oscillator

The oscillator uses an external resistor and capacitor to set the system clock frequency. Multiple clock frequencies can be selected using different combinations of resistors and capacitors. Figure 2 shows a simplifier block diagram for the system oscillator.

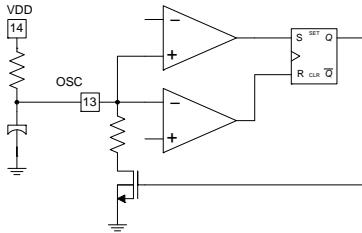

Figure 2. Block Diagram of System Oscillator Circuit

LDO Regulator

The LDO regulator provides the reference voltage for the sensor and all other analog blocks within the system. The nominal voltage reference for the sensor is 2.7 V ±5%. An external capacitor is needed on the VREF pin to guarantee stability of the regulator.

Differential Amplifiers

The two differential amplifiers can be configured as a bandpass filter to condition the PIR sensor signal for the post

digital signal processing. The cutoff frequencies and passband gain are set by the external components. See Figure 5.

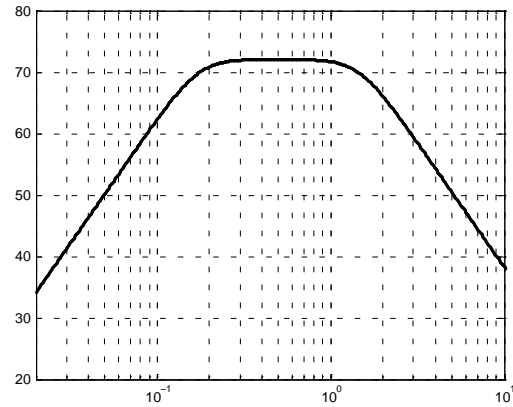

Figure 3. Plot Showing Typical Magnitude Response of Differential Amplifiers When Configured as a Bandpass Filter

Window Comparator

The window comparator compares the voltage from the second differential amplifier to two reference voltages from the LDO regulator. COMP_P triggers if OP2_O is greater than the Vh voltage and COMP_N triggers if OP2_O is lower than the Vl voltage. See Figures 4 and 5.

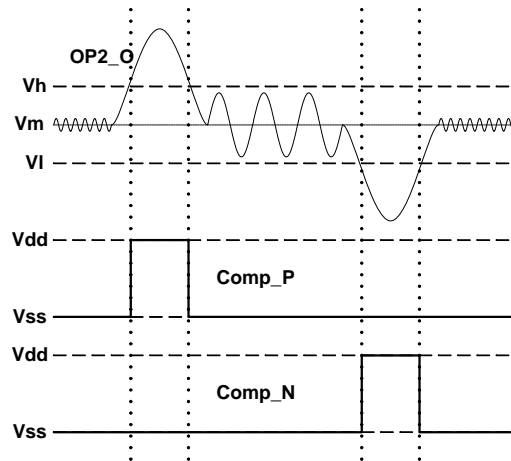

Figure 4. Plot Showing Functionality of Window Comparator for an Analog Input OP2_O

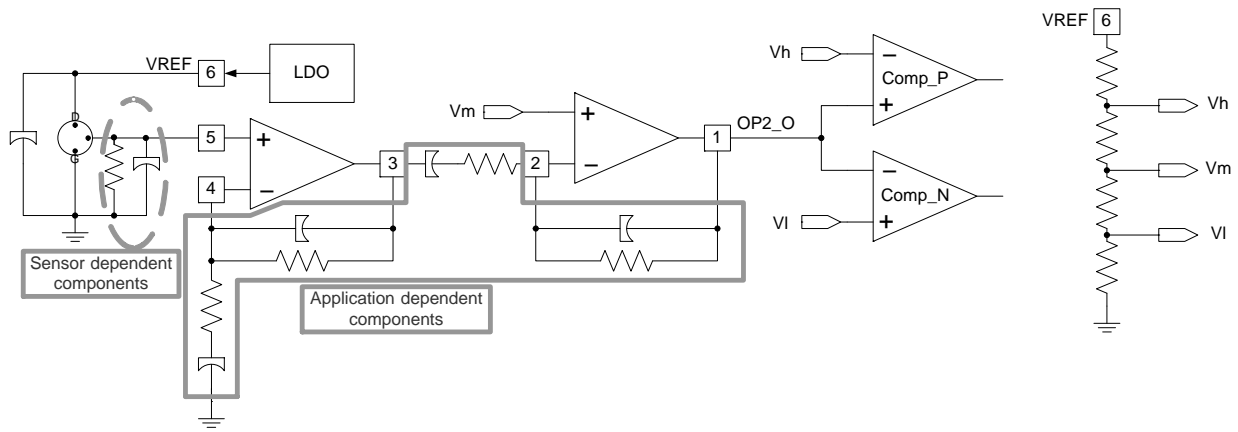

Figure 5. Figure Showing Simplified Block Diagram of Analog Conditioning Stages

Digital Signal Processing Block (all times assume a 62.5 Hz system oscillator frequency)

The digital signaling processing block performs three major functions.

The first function is that the device toggles LED during the start-up sequencing at approximately two hertz regardless of the state of the XLED_EN pin. The startup sequence lasts for thirty seconds. During that time the OUT pin is held low regardless of the state of OP2_O.

The second function of the digital signal processing block is to insure a certain glitch width is seen before OUT is toggled. The digital signal processing block is synchronous with the system oscillator frequency and therefore the deglitch time is related to when the comparators toggle within the oscillator period. A signal width less than two clock period is guaranteed to be deglitched as a zero. A signal width of greater than three clock cycles is guaranteed to be de-glitched. It should be noted that down-sampling can occur if sufficient anti-aliasing is not performed at the input of the circuit (OPI_P) or if noise is injected into the amplifiers, an example would be a noisy power supply.

The third function of the digital signal processing block is to recognize different pulse signatures coming from the window comparator block. The device is equipped with two pulse recognition routines. Single pulse mode (MODE tied to VSS) will trigger the OUT pin if either comparator toggles and the deglitch time is of the appropriate length. (See Figure 6). Dual pulse mode (MODE tied to V_{DD}) requires two pulses with each pulse coming from the opposite comparator to occur within a timeout window of five seconds or 312 clock cycles (See Figure 7). If the adjacent pulses occur outside the timeout window then the digital processing block will restart the pulse recognition routine.

xLED_EN Pin

The xLED_EN pin enables the LED output driver when motion has been detected. If xLED_EN is tied high the LED pin will not toggle after motion is detected. If the xLED_EN is tied low the LED pin will toggle when motion is detected. During start-up the LED pin will toggle irrespective of how the xLED_EN pin is tied. (See Figure 6).

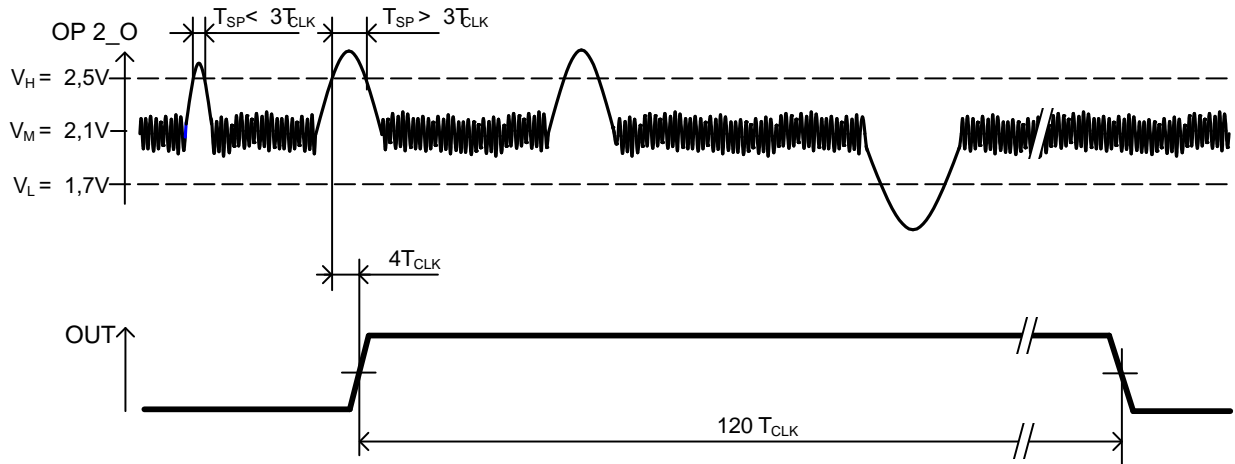

Figure 6. Timing Diagram for Single-Pulse Mode Detection

NCS36000

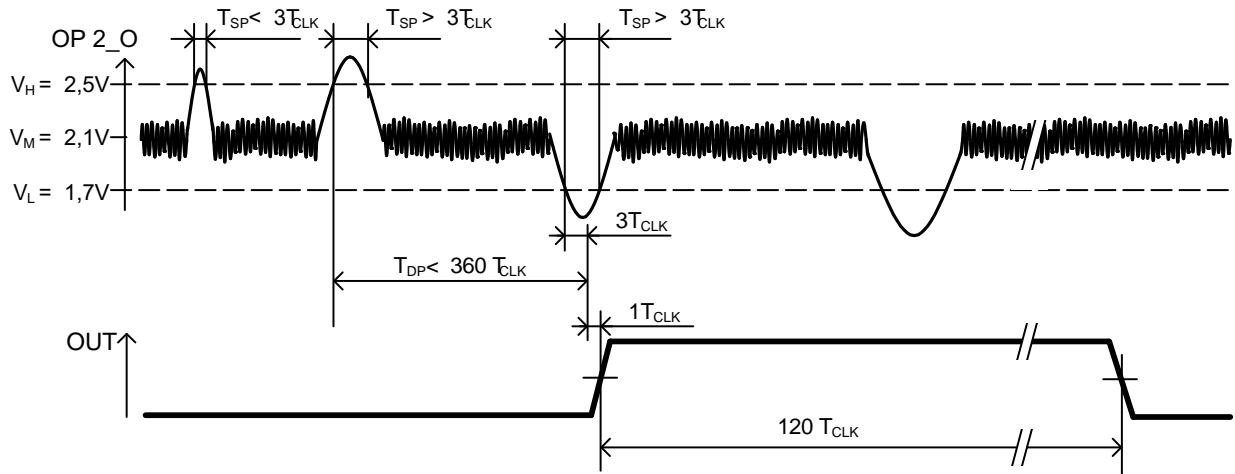

Figure 7. Timing Diagram for Dual-Pulse Mode Detection

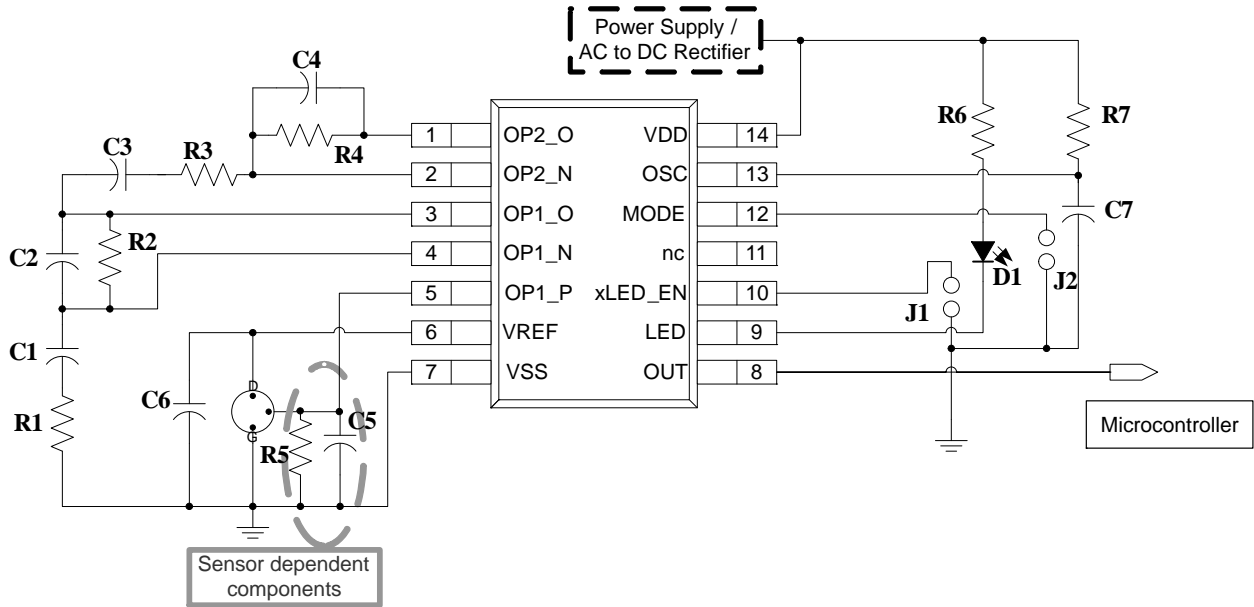

Figure 8. Typical Application Diagram Using NCS36000

R1 = 10 kΩ	C1 = 33 μF	J1 (Jumper for xLED_EN)
R2 = 560 kΩ	C2 = 10 nF	J2 (Jumper for Mode Select)
R3 = 10 kΩ	C3 = 33 μF	D1 (LED)
R4 = 560 kΩ	C4 = 10 nF	
R5 = 43 kΩ	C5 = 100 nF	
R6 = 1 kΩ	C6 = 100 nF	
R7 = 220 kΩ	C7 = 100 nF	

9. R1, C1, R2, C2, R3, C3, R4, C4 setup bandpass filter characteristics. With components as shown above the passband gain is approximately 70 dB with the 3 dB cutoff frequency of the filter at approximately 700 mHz and 20 Hz.
10. R4 can be replaced by a potentiometer to adjust sensitivity of system. Note dynamically changing R4 will also change the pole location for the second amplifier.
11. R5 and C5 are sensor dependant components and R6 may need to be adjusted to guarantee the AMP 1 IN parameter outlined within the Operating Ranges section of this document.
12. R7 and C7 may be adjusted to change the oscillator frequency. R7 may not be smaller than 50 kΩ.

NCS36000

ORDERING INFORMATION

Device	Package	Shipping†
NCS36000DG	SOIC-14 (Pb-Free)	55 Units / Rail
NCS36000DRG	SOIC-14 (Pb-Free)	3000 / Tape & Reel

†For information on tape and reel specifications, including part orientation and tape sizes, please refer to our Tape and Reel Packaging Specifications Brochure, BRD8011/D.

MECHANICAL CASE OUTLINE PACKAGE DIMENSIONS

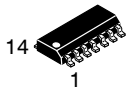

SCALE 1:1

SOIC-14 NB
CASE 751A-03
ISSUE L

DATE 03 FEB 2016

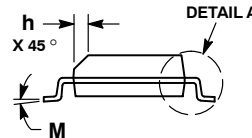
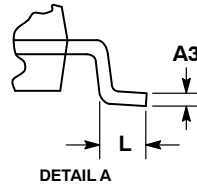
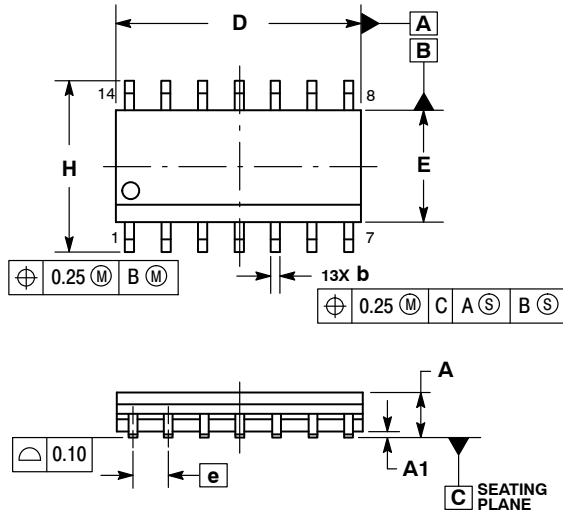

NOTES:

1. DIMENSIONING AND TOLERANCING PER ASME Y14.5M, 1994.
2. CONTROLLING DIMENSION: MILLIMETERS.
3. DIMENSION b DOES NOT INCLUDE DAMBAR PROTRUSION. ALLOWABLE PROTRUSION SHALL BE 0.13 TOTAL IN EXCESS OF AT MAXIMUM MATERIAL CONDITION.
4. DIMENSIONS D AND E DO NOT INCLUDE MOLD PROTRUSIONS.
5. MAXIMUM MOLD PROTRUSION 0.15 PER SIDE.

DIM	MILLIMETERS		INCHES	
	MIN	MAX	MIN	MAX
A	1.35	1.75	0.054	0.068
A1	0.10	0.25	0.004	0.010
A3	0.19	0.25	0.008	0.010
b	0.35	0.49	0.014	0.019
D	8.55	8.75	0.337	0.344
E	3.80	4.00	0.150	0.157
e	1.27 BSC		0.050 BSC	
H	5.80	6.20	0.228	0.244
h	0.25	0.50	0.010	0.019
L	0.40	1.25	0.016	0.049
M	0°	7°	0°	7°

SOLDERING FOOTPRINT*

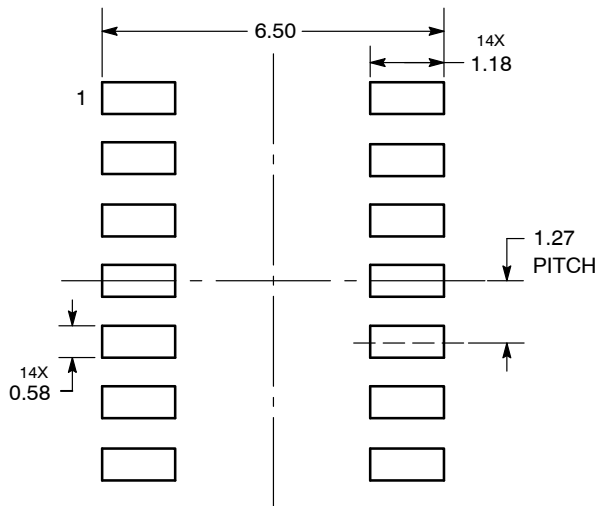

DIMENSIONS: MILLIMETERS

*For additional information on our Pb-Free strategy and soldering details, please download the ON Semiconductor Soldering and Mounting Techniques Reference Manual, SOLDERRM/D.

GENERIC MARKING DIAGRAM*

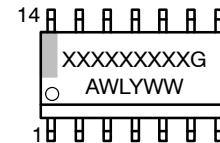

- XXXXXX = Specific Device Code
- A = Assembly Location
- WL = Wafer Lot
- Y = Year
- WW = Work Week
- G = Pb-Free Package

*This information is generic. Please refer to device data sheet for actual part marking. Pb-Free indicator, "G" or microdot "▪", may or may not be present. Some products may not follow the Generic Marking.

STYLES ON PAGE 2

DOCUMENT NUMBER:	98ASB42565B	Electronic versions are uncontrolled except when accessed directly from the Document Repository. Printed versions are uncontrolled except when stamped "CONTROLLED COPY" in red.
DESCRIPTION:	SOIC-14 NB	PAGE 1 OF 2

onsemi and onsemi are trademarks of Semiconductor Components Industries, LLC dba onsemi or its subsidiaries in the United States and/or other countries. onsemi reserves the right to make changes without further notice to any products herein. onsemi makes no warranty, representation or guarantee regarding the suitability of its products for any particular purpose, nor does onsemi assume any liability arising out of the application or use of any product or circuit, and specifically disclaims any and all liability, including without limitation special, consequential or incidental damages. onsemi does not convey any license under its patent rights nor the rights of others.

SOIC-14
CASE 751A-03
ISSUE L

DATE 03 FEB 2016

STYLE 1:
 PIN 1. COMMON CATHODE
 2. ANODE/CATHODE
 3. ANODE/CATHODE
 4. NO CONNECTION
 5. ANODE/CATHODE
 6. NO CONNECTION
 7. ANODE/CATHODE
 8. ANODE/CATHODE
 9. ANODE/CATHODE
 10. NO CONNECTION
 11. ANODE/CATHODE
 12. ANODE/CATHODE
 13. NO CONNECTION
 14. COMMON ANODE

STYLE 2:
 CANCELLED

STYLE 3:
 PIN 1. NO CONNECTION
 2. ANODE
 3. ANODE
 4. NO CONNECTION
 5. ANODE
 6. NO CONNECTION
 7. ANODE
 8. ANODE
 9. ANODE
 10. NO CONNECTION
 11. ANODE
 12. ANODE
 13. NO CONNECTION
 14. COMMON CATHODE

STYLE 4:
 PIN 1. NO CONNECTION
 2. CATHODE
 3. CATHODE
 4. NO CONNECTION
 5. CATHODE
 6. NO CONNECTION
 7. CATHODE
 8. CATHODE
 9. CATHODE
 10. NO CONNECTION
 11. CATHODE
 12. CATHODE
 13. NO CONNECTION
 14. COMMON ANODE

STYLE 5:
 PIN 1. COMMON CATHODE
 2. ANODE/CATHODE
 3. ANODE/CATHODE
 4. ANODE/CATHODE
 5. ANODE/CATHODE
 6. NO CONNECTION
 7. COMMON ANODE
 8. COMMON CATHODE
 9. ANODE/CATHODE
 10. ANODE/CATHODE
 11. ANODE/CATHODE
 12. ANODE/CATHODE
 13. NO CONNECTION
 14. COMMON ANODE

STYLE 6:
 PIN 1. CATHODE
 2. CATHODE
 3. CATHODE
 4. CATHODE
 5. CATHODE
 6. CATHODE
 7. CATHODE
 8. ANODE
 9. ANODE
 10. ANODE
 11. ANODE
 12. ANODE
 13. ANODE
 14. ANODE

STYLE 7:
 PIN 1. ANODE/CATHODE
 2. COMMON ANODE
 3. COMMON CATHODE
 4. ANODE/CATHODE
 5. ANODE/CATHODE
 6. ANODE/CATHODE
 7. ANODE/CATHODE
 8. ANODE/CATHODE
 9. ANODE/CATHODE
 10. ANODE/CATHODE
 11. COMMON CATHODE
 12. COMMON ANODE
 13. ANODE/CATHODE
 14. ANODE/CATHODE

STYLE 8:
 PIN 1. COMMON CATHODE
 2. ANODE/CATHODE
 3. ANODE/CATHODE
 4. NO CONNECTION
 5. ANODE/CATHODE
 6. ANODE/CATHODE
 7. COMMON ANODE
 8. COMMON ANODE
 9. ANODE/CATHODE
 10. ANODE/CATHODE
 11. NO CONNECTION
 12. ANODE/CATHODE
 13. ANODE/CATHODE
 14. COMMON CATHODE

DOCUMENT NUMBER:	98ASB42565B	Electronic versions are uncontrolled except when accessed directly from the Document Repository. Printed versions are uncontrolled except when stamped "CONTROLLED COPY" in red.
DESCRIPTION:	SOIC-14 NB	PAGE 2 OF 2

onsemi and **ONSEMI** are trademarks of Semiconductor Components Industries, LLC dba **onsemi** or its subsidiaries in the United States and/or other countries. **onsemi** reserves the right to make changes without further notice to any products herein. **onsemi** makes no warranty, representation or guarantee regarding the suitability of its products for any particular purpose, nor does **onsemi** assume any liability arising out of the application or use of any product or circuit, and specifically disclaims any and all liability, including without limitation special, consequential or incidental damages. **onsemi** does not convey any license under its patent rights nor the rights of others.

onsemi, **Onsemi**, and other names, marks, and brands are registered and/or common law trademarks of Semiconductor Components Industries, LLC dba "**onsemi**" or its affiliates and/or subsidiaries in the United States and/or other countries. **onsemi** owns the rights to a number of patents, trademarks, copyrights, trade secrets, and other intellectual property. A listing of **onsemi**'s product/patent coverage may be accessed at www.onsemi.com/site/pdf/Patent-Marking.pdf. **onsemi** reserves the right to make changes at any time to any products or information herein, without notice. The information herein is provided "as-is" and **onsemi** makes no warranty, representation or guarantee regarding the accuracy of the information, product features, availability, functionality, or suitability of its products for any particular purpose, nor does **onsemi** assume any liability arising out of the application or use of any product or circuit, and specifically disclaims any and all liability, including without limitation special, consequential or incidental damages. Buyer is responsible for its products and applications using **onsemi** products, including compliance with all laws, regulations and safety requirements or standards, regardless of any support or applications information provided by **onsemi**. "Typical" parameters which may be provided in **onsemi** data sheets and/or specifications can and do vary in different applications and actual performance may vary over time. All operating parameters, including "Typicals" must be validated for each customer application by customer's technical experts. **onsemi** does not convey any license under any of its intellectual property rights nor the rights of others. **onsemi** products are not designed, intended, or authorized for use as a critical component in life support systems or any FDA Class 3 medical devices or medical devices with a same or similar classification in a foreign jurisdiction or any devices intended for implantation in the human body. Should Buyer purchase or use **onsemi** products for any such unintended or unauthorized application, Buyer shall indemnify and hold **onsemi** and its officers, employees, subsidiaries, affiliates, and distributors harmless against all claims, costs, damages, and expenses, and reasonable attorney fees arising out of, directly or indirectly, any claim of personal injury or death associated with such unintended or unauthorized use, even if such claim alleges that **onsemi** was negligent regarding the design or manufacture of the part. **onsemi** is an Equal Opportunity/Affirmative Action Employer. This literature is subject to all applicable copyright laws and is not for resale in any manner.

ADDITIONAL INFORMATION

TECHNICAL PUBLICATIONS:

Technical Library: www.onsemi.com/design/resources/technical-documentation
onsemi Website: www.onsemi.com

ONLINE SUPPORT: www.onsemi.com/support

For additional information, please contact your local Sales Representative at www.onsemi.com/support/sales