



M12 X-coded 10G transformer receptacles



GENERAL INFORMATION

No. of contacts	8 poles
Contact resistance	< 5 mOhm
Working temperature range	-40°C - +85°C
Termination technology	SMT
Reflow processing temperature	245°C Max.
Total insertion force	30N Max. according to IEC 61076-2-109
Total withdrawal force	30N Max. according to IEC 61076-2-109
Mating cycles	100 mating cycles, according to IEC 61076-2-109
Shock and vibration proof	according to IEC 61076-2-109
RoHS - compliant	Yes
Lead free	Yes
PSL level acc. ECA/IPC/JEDEC J-STD-075	R7

INSULATION MATERIAL

Material	LCP (liquid crystalline polymer)
Color	Black
UL classification	UL94-V0
Material group acc. IEC 60664-1	IIIa (175 ≤ CTI < 400)

CONTACT MATERIAL

Contact material	Copper alloy
Plating termination zone	Tin
Plating contact sliding side	Gold

SHIELDING MATERIAL

Shielding material	Copper alloy
Plating	Tin

Recommended Panel cut out

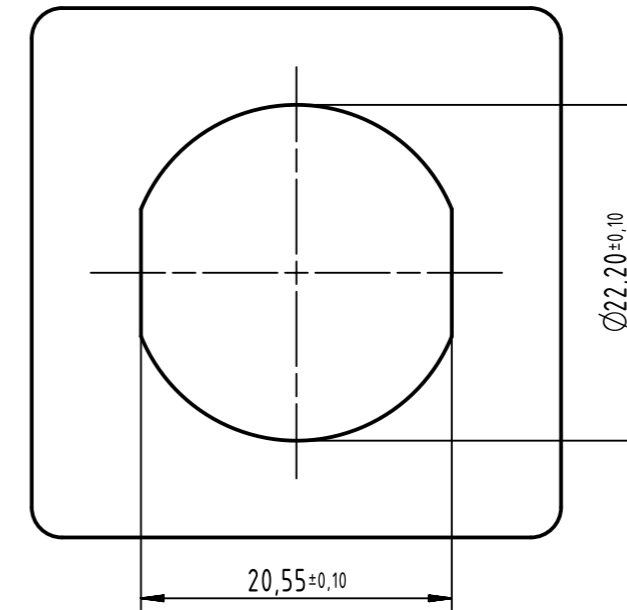

Front mounting use
Detail see drawing 21033012006

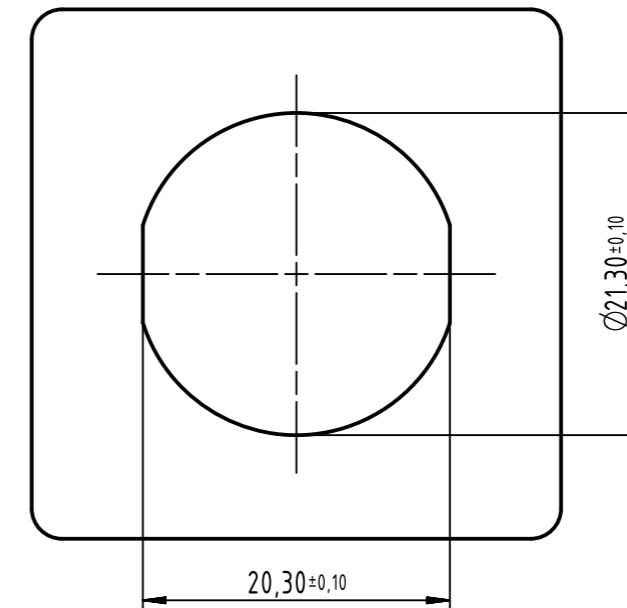

Rear mounting use
Detail see drawing 21033012007

	All Dimensions in mm Original Size DIN A3	Scale 1:1	Free size tol.	Ref.
				Sub.
	All rights reserved	Created by 402664	Inspected by ZENGO	Standardisation 302077
	Department EL PD	Date 2021-03-15		State Final Release
HARTING D-32339 Espelkamp		Title M12 transformer receptacles X-coded 10G angled, SMT		Doc-Key / ECM-Nr. 100723745/UGD/001/E 500000191093
		Type DS	Number 21033810203	Rev. E Page 1/4

Schematic

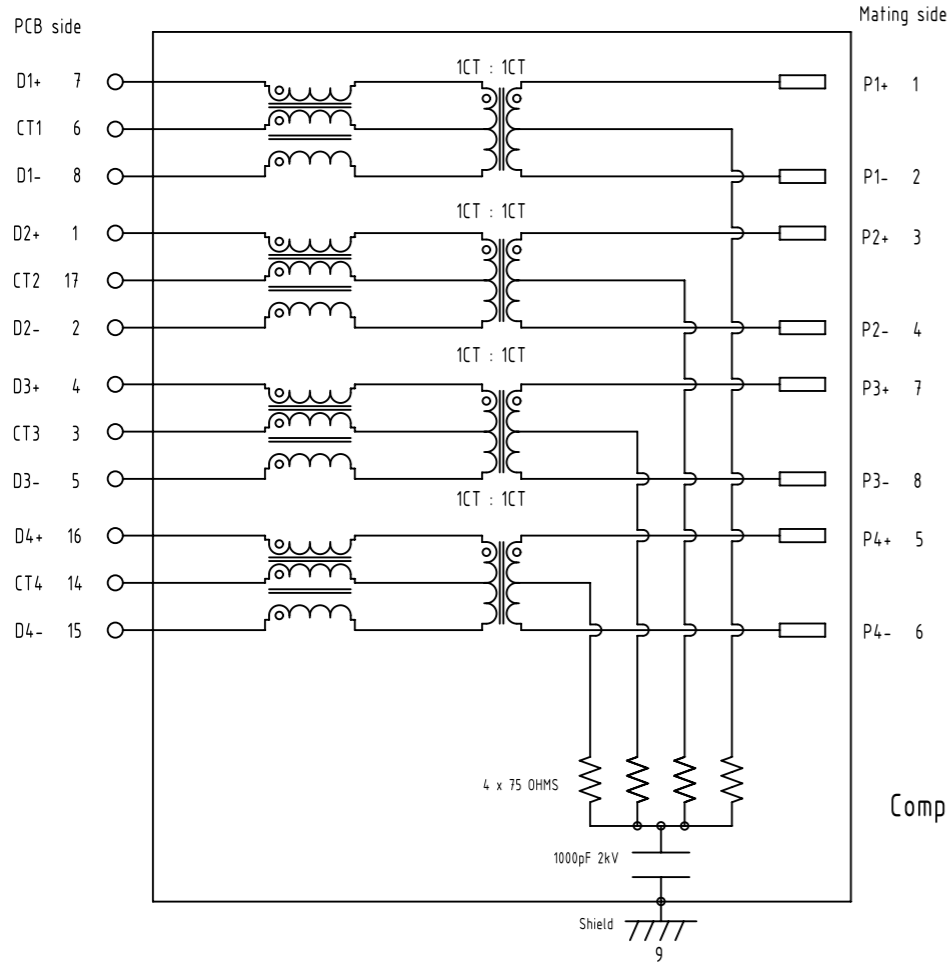

Recommended PCB layout

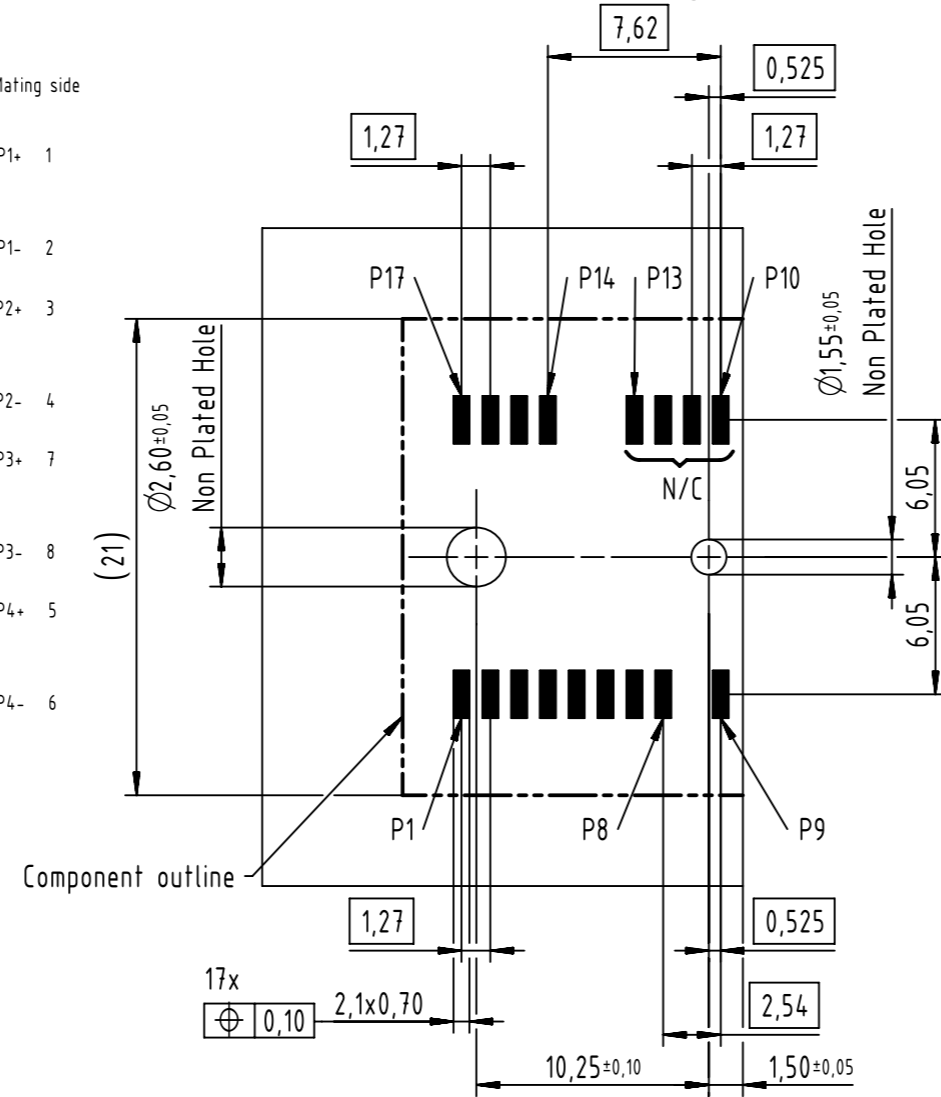

Electrical Characteristics @+25°C unless otherwise noted
Meets IEEE802.3 specification
RoHS compliant

Parameter	Specification/ Limit Values
Operating Temperature	40°C - +85°C
Turn Ratio (+/- 2%)	1CT : 1CT
Current Capacity Pins 1-8 / VC1-VC4	750mA
OCL	min 120µH @ 100KHz , 100mV with 18mA bias current
Isolation (Input- Output)	2.25kV VDC , for 60sec. min
	0.1MHz < f ≤ 500 MHz
Insertion Loss	3.1 db
Return Loss	5 db
Crosstalk	23 db
CMRR	20 db
CDMR	20 db

NOTE: 1. f is the frequency in MHz

2. The Product has been tested for DC isolation. HARTING assumes no liability or obligation for AC isolation testing.

3. Please note that the M12 Magnetics connector generates less high frequency losses (1-3GHz) compared to an RJ45 with magnetics. In combination with Chipsets that require high frequency losses to pass the PSD test, it is recommended to add a Lowpass filtering network to the M12 10G Magnetics PCB-side for 10GBASE-t signalling (see Detail A)

Detail A

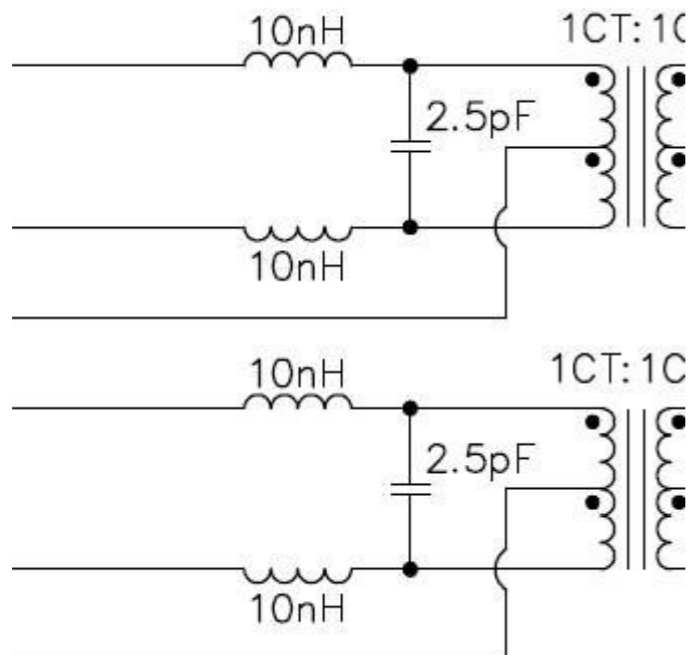

For X-coded 10G without PoE version only
N/C: leave all pins floating. Do not connect to any of the pins to any net

	All rights reserved	Created by 402664	Inspected by ZENGO	Standardisation 302077	Date 2021-03-15	State Final Release
	Department EL PD	Title M12 transformer receptacles X-coded 10G angled, SMT		Doc-Key / ECM-Nr. 100723745/UGD/001/E 500000191093		
HARTING D-32339 Espelkamp	Type DS	Number 21033810203		Rev. E	Page 2/4	

Schematic

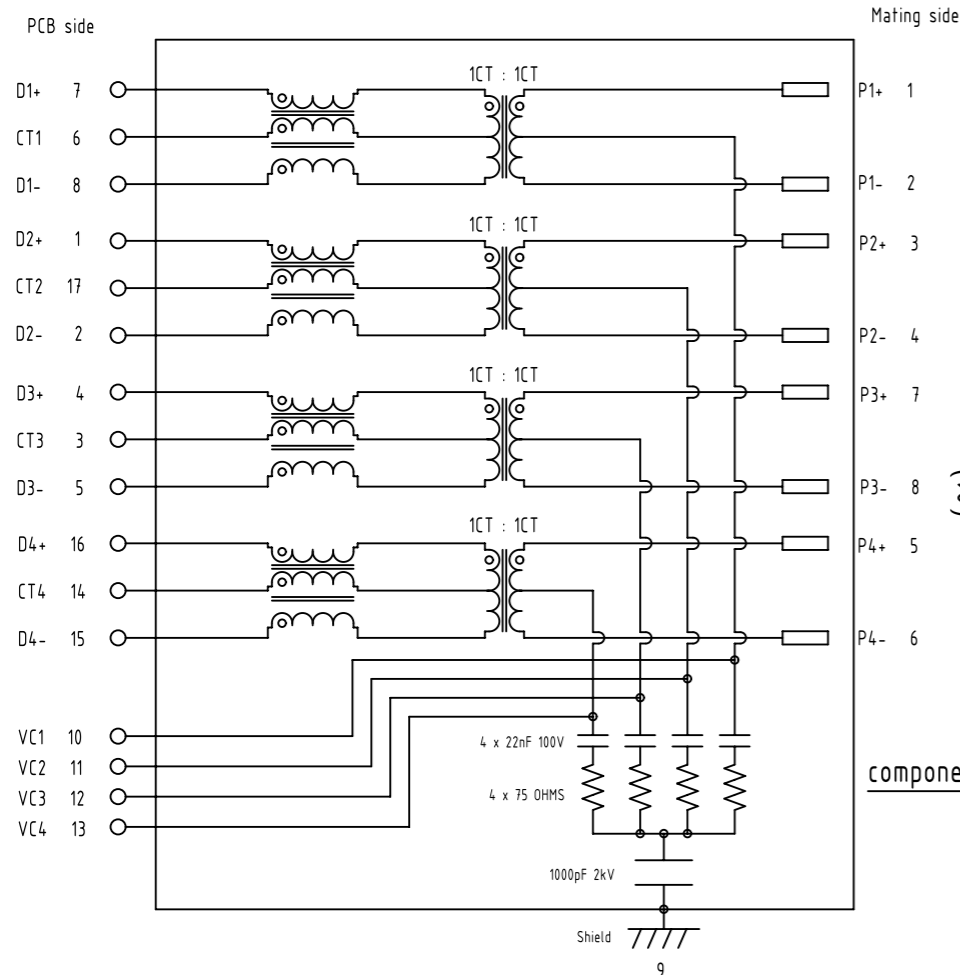

Recommended PCB layout

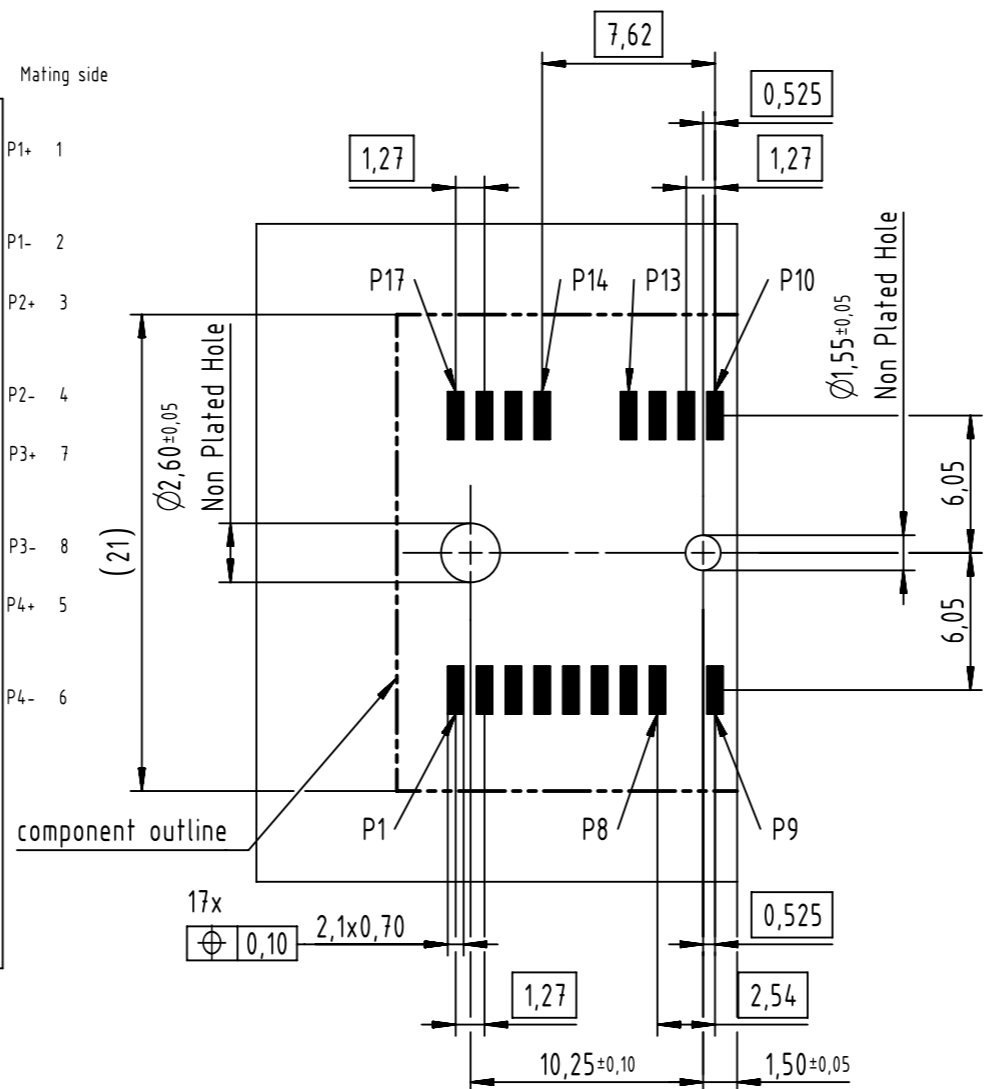

Electrical Characteristics @+25°C unless otherwise noted
 Meets IEEE802.3 specification
 RoHS compliant

Parameter	Specification/ Limit Values
Operating Temperature	-40°C - +85°C
Turn Ratio (+/- 2%)	1CT : 1CT
Current Capacity Pins 1-8/ VC1-VC4	750mA
OCL	min 120µH @ 100KHz , 100mV with 18mA bias current
Isolation (Input- Output)	2.25kV VDC , for 60sec. min
	0.1MHz < f ≤ 500 MHz
Insertion Loss	3.1 db
Return Loss	5 db
Crosstalk	23 db
CMRR	20 db
CDMR	20 db

NOTE: 1. f is the frequency in MHz
 2. The Product has been tested for DC isolation. HARTING assumes no liability or obligation for AC isolation testing.
 3. Please note that the M12 Magnetics connector generates less high frequency losses (1-3GHz) compared to an RJ45 with magnetics. In combination with Chipsets that require high frequency losses to pass the PSD test, it is recommended to add a Lowpass filtering network to the M12 10G Magnetics PCB-side for 10GBASE-t signalling (see Detail A)

Detail A

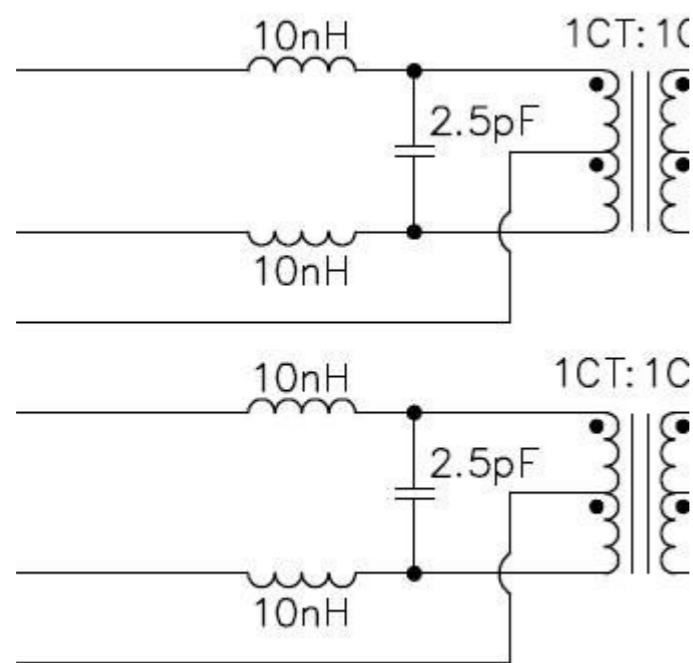

For X-coded 10G with PoE+ version only

	All rights reserved Department EL PD	Created by 402664	Inspected by ZENGO	Standardisation 302077	Date 2021-03-15	State Final Release
	Title M12 transformer receptacles X-coded 10G angled, SMT Type DS Number 21033810203					Doc-Key / ECM-Nr. 100723745/UGD/001/E 500000191093
HARTING D-32339 Espelkamp						Rev. E Page 3/4

TAPE LAYOUT & PACKAGING

RECOMMENDATION FOR SOLDER PROCESSING

1. PCB pad plating

The M12 transformer receptacle connectors are solderable on lead-free pad surfaces like HAL,NiAu,Immersion Sn.

2. Stencil recommendation

The size of the solder stencil apertures is depending on the thickness of the stencil.

In general, thinner stencils will need larger apertures to result in the required volume of solder paste.

The minimum required solder paste volume for the signal pins is 0,160mm³,For example, this can be achieved with the following stencil data :

Single pin			
Stencil thickness	PCB pad size	proposal stencil aperture size	calculated solder paste volume
120 µm	2,1 x 0,7 mm	2,05 x 0,65 mm	0,160 mm ³

HARD TRAY LAYOUT & PACKAGING

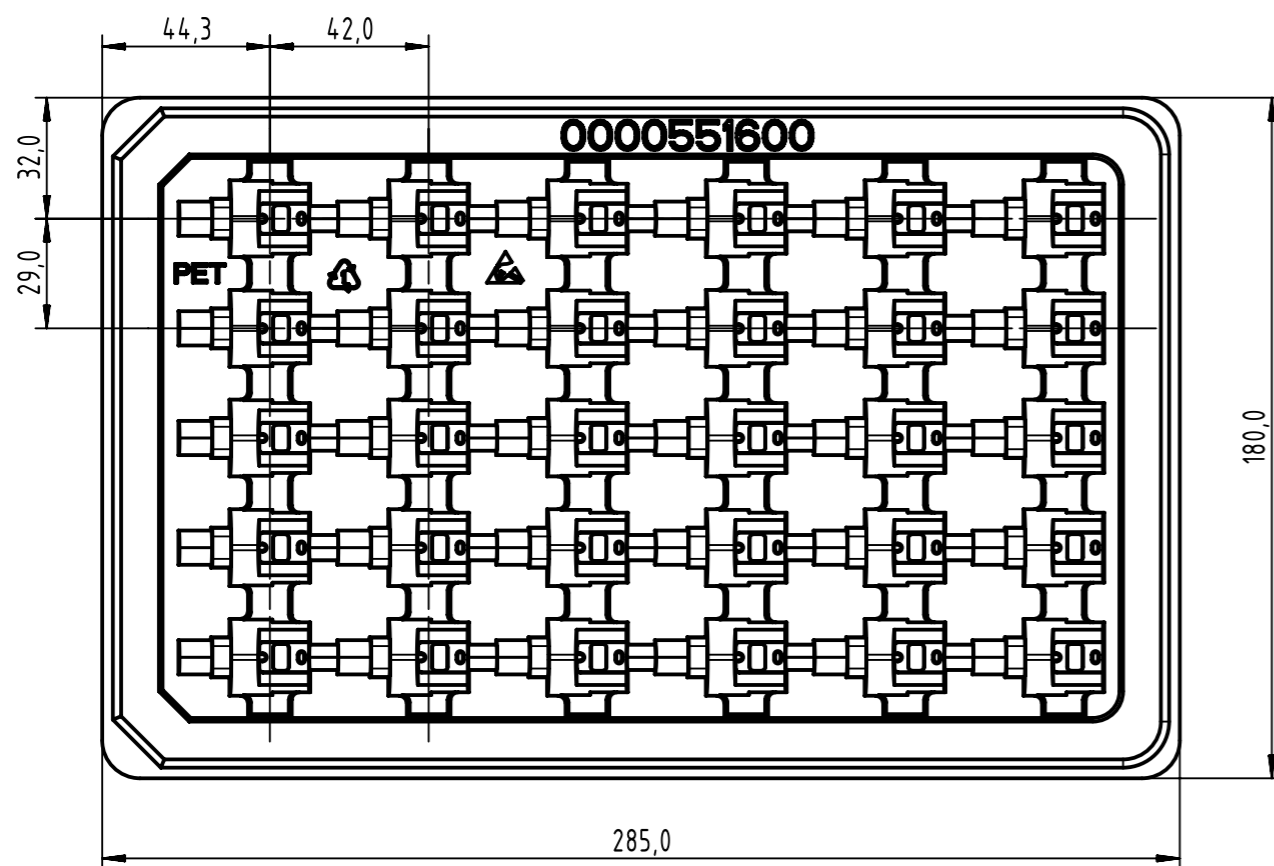

APPLICATION INFORMATION

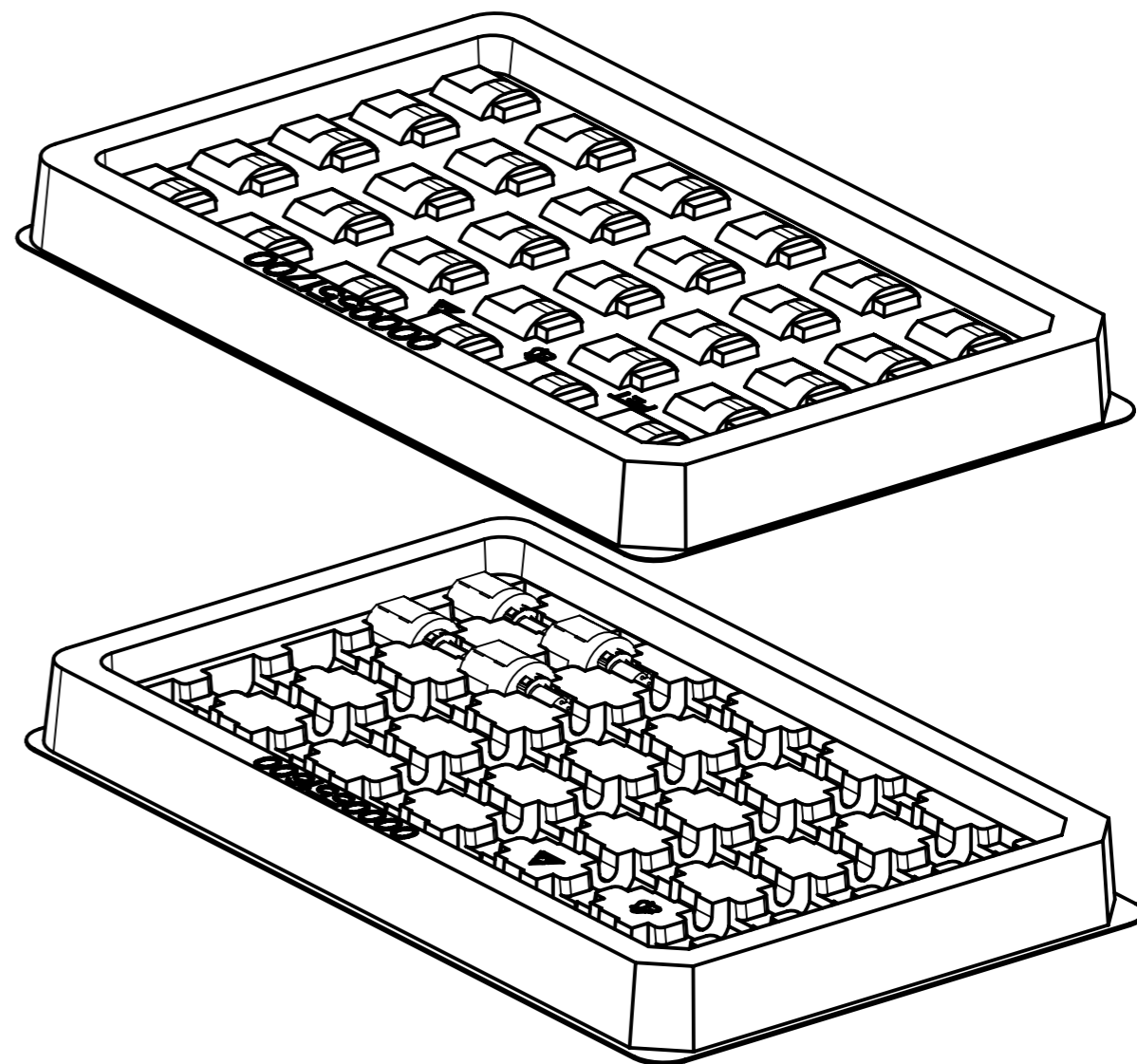

	All rights reserved Department EL PD	All Dimensions in mm Original Size DIN A3	Scale 1:1	Free size tol.	Ref. Sub.
		Created by 402664	Inspected by ZENG0	Standardisation 302077	Date 2021-03-15
HARTING D-32339 Espelkamp		Title M12 transformer receptacles X-coded 10G angled, SMT			Doc-Key / ECM-Nr. 100723745/UGD/001/E 500000191093
		Type DS	Number 21033810203		Rev. E Page 4/4