

THIS DRAWING IS UNPUBLISHED. RELEASED FOR PUBLICATION  
 © COPYRIGHT - By - ALL RIGHTS RESERVED.

LOC	DIST	REVISIONS					
		P	LTR	DESCRIPTION	DATE	DWN	APVD
-	-		J2	NEW DRAWING PER ECO-11-019045	02APR12	KH	DR

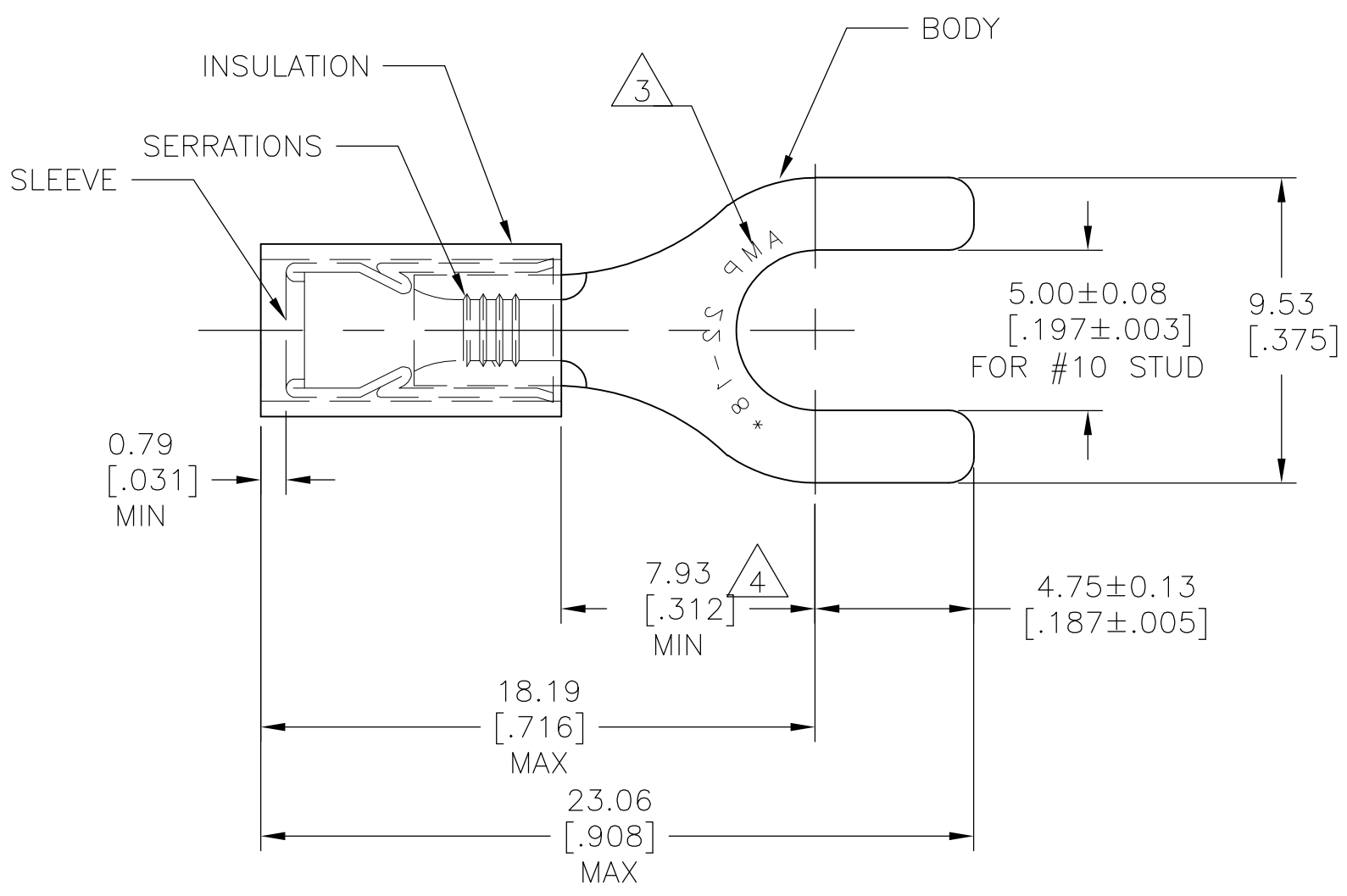

<b>AMP</b> WIRE RANGE	Listed FILE E13288	LR7189 Certified
22-16 AWG SOLID OR STRANDED	22-16 AWG SOLID OR STRANDED	22-16 AWG SOLID OR STRANDED

- 1 TONGUE MATERIAL THK: 0.79±0.05[.031±.002]
- 2 FOR WIRE INSULATION DIA: 2.67[.105] TO 3.56[.140]
- 3 STAMP AMP 22-18\* APPROX AS SHOWN. 22-16 TERMINALS ARE STAMPED 22-18 IN ACCORDANCE WITH MILITARY SPEC SAE AS 7928, COMMERCIAL WIRE RANGE IS 22-16
- 4 DIMENSION APPLIES FROM EDGE OF METAL WIRE BARREL TO CENTER OF STUD.
- 5 MATERIAL:  
BODY&SLEEVE: COPPER PER ASTM B152  
INSULATION: NYLON.
- 6 FINISH:  
BODY&SLEEVE: TIN PLATE PER ASTM B545  
INSULATION: COLOR-RED

100	LOOSE PC, BOX	8-32054-1
5000	ON TAPE REEL	2-32054-1
1000	LOOSE PIECE	32054
QTY	PACKAGE TYPE	PART NO

### AMP INCORPORATED CUSTOMER SERVICE SYSTEMS

FOR ADDITIONAL PRODUCT INFORMATION OR COPIES OF DRAWINGS AND TECHNICAL DOCUMENTS	PRODUCT INFORMATION CENTER 1-800-522-6752	RECOMMENDED OPERATING TEMPERATURE: 105°C [221°F]
FOR APPLICATION TOOLING INFORMATION	TOOLING ASSISTANCE CENTER 1-800-722-1111	VOLTAGE RATING: 300V MAX
FOR ORDER ENTRY	1-800-526-5142	WIRE CROSS SECTIONAL AREA RANGE: 0.26-1.65mm <sup>2</sup> [509 -3260] SOLID OR STRANDED

THIS DRAWING IS A CONTROLLED DOCUMENT.

DIMENSIONS: mm [INCHES]	TOLERANCES UNLESS OTHERWISE SPECIFIED:
	0 PLC ± -
	1 PLC ± -
	2 PLC ± 0.20[.008]
	3 PLC ± -
	4 PLC ± -
	ANGLES ± 5°
MATERIAL	FINISH
5	6

DWN KIRAN HOLAL 02APR12	TE Connectivity	NAME		TERMINAL P.I.D.G, SPADE WIRE SIZE: 22-16		
CHK ROHDE DANIEL 02APR12		APVD ROHDE DANIEL 02APR12		RESTRICTED TO		
APVD ROHDE DANIEL 02APR12		PRODUCT SPEC	APPLICATION SPEC	SIZE	CAGE CODE	DRAWING NO
APVD ROHDE DANIEL 02APR12		WEIGHT	-	A3	00779	C-32054
CUSTOMER DRAWING			SCALE	SHEET	REV	
			5:1	1 OF 1	J2	