

ALTERNATIVE PROFILE
INTERNAL PROFILE MAY VARY

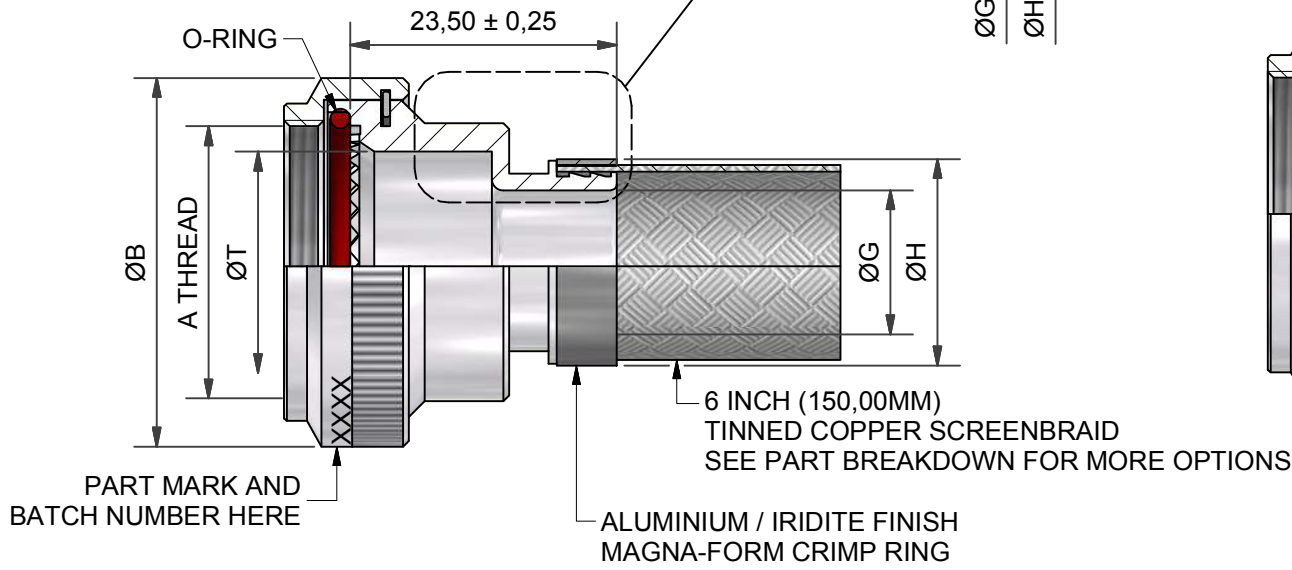

ANGLE 1

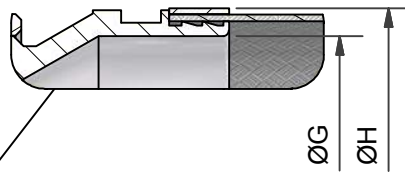
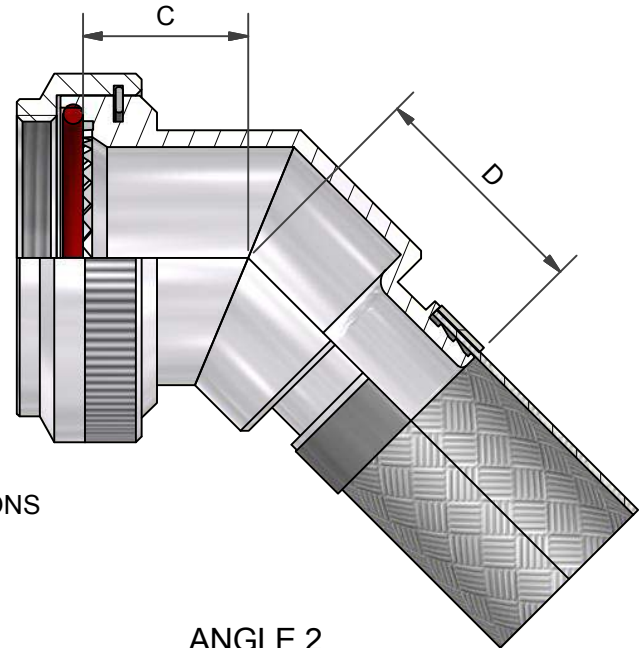

ANGLE 2

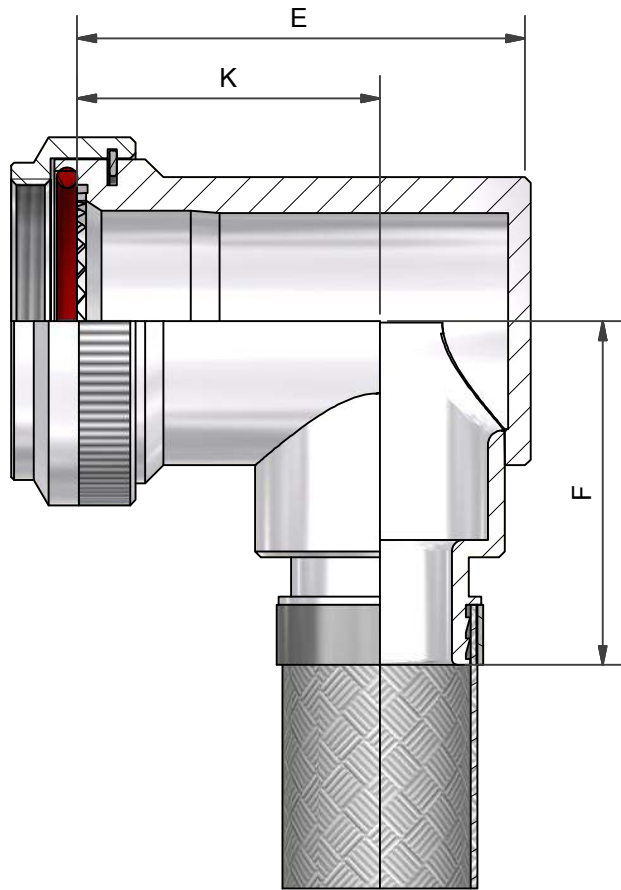

90° BACKSHELL - ANGLE 3
ALUMINIUM ALLOY

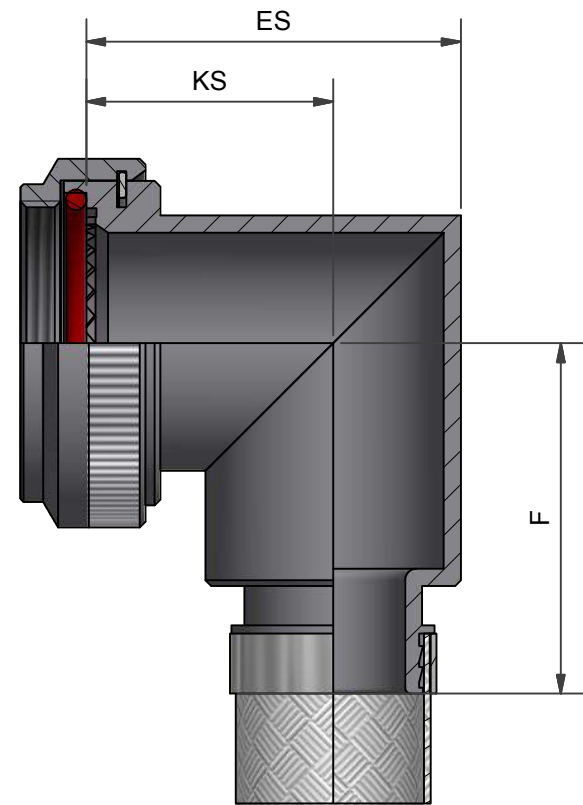

90° BACKSHELL - ANGLE 3
STAINLESS STEEL AND
NICKEL ALUMINIUM BRONZE

DRAWN		DATE		 3RD ANGLE PROJECTION NOT TO SCALE	PART NUMBER:			70H SERIES				
K.WINCZURA		25/04/2018			TITLE:						BRAID TAIL BACKSHELL	
DESIGN APPROVAL		DATE		UNLESS OTHERWISE SPECIFIED ALL DIMENSIONS IN MILLIMETRES GENERAL TOL LINEAR +/- 0,25MM ANGULAR +/- 1°				ASSY USED ON: MIL-CTL-38999 SERIES III & IV				
K.SHEPPARD		18/09/2013			MATERIAL SEE PART NUMBER BREAKDOWN FINISH SEE PART NUMBER BREAKDOWN						THIS DRAWING IS COPYRIGHT AND THE PROPERTY OF POLAMCO LTD IT MUST NOT BE COPIED, USED FOR MANUFACTURE OR OTHERWISE DISCLOSED WITHOUT PRIOR WRITTEN CONSENT OF THE COMPANY.	
DOC TYPE	Customer Drawing			POLAMCO LTD, WESTON LOCK, LOWER BRISTOL ROAD BATH BA2 1EP				SHT 1				
ISSUE/REV	CA	DCR	6777				NCAGE CODE U5792				WEIGHT N/A	

TABLE 1

SHELL SIZE	A THREAD	ØB MAX	ØT MIN	C MAX	D ±0,5	E MAX	F MAX	K ±0,5	ES MAX	KS ±0,5
09	M12 x 1.0	18,0	6,7	13,1	17,1	25,7	24,0	17,5	21,5	16,3
11	M15 x 1.0	21,0	10,2	13,9	18,2	26,7	25,7	17,5	24,6	17,2
13	M18 x 1.0	24,5	13,5	14,5	18,6	31,2	27,2	20,0	28,6	19,4
15	M22 x 1.0	29,0	16,2	15,5	19,5	37,2	28,7	24,5	31,3	21,0
17	M25 x 1.0	32,5	19,4	16,1	20,3	40,2	30,4	26,7	34,5	22,8
19	M28 x 1.0	35,5	21,8	16,8	20,8	44,7	32,0	27,0	38,7	25,3
21	M31 x 1.0	37,0	25,1	17,1	21,7	49,2	33,6	30,5	41,0	26,1
23	M34 x 1.0	40,0	28,2	17,7	22,0	51,7	35,1	31,5	43,9	27,6
25	M37 x 1.0	43,5	31,4	18,4	22,9	53,2	36,6	28,5	46,7	29,1

TABLE 2

ENTRY SIZE	ØG MIN	ØH MAX
03	4,77	13,60
04	6,35	13,60
05	7,92	13,60
06	9,52	18,40
07	11,12	18,40
08	12,70	18,40
09	14,27	18,40
10	15,87	24,70
11	17,47	24,70
12	19,05	24,70
13	20,62	24,70
14	22,23	31,10
15	23,82	31,10
16	25,40	31,10
17	26,98	33,70
18	28,60	33,70
19*	30,20	36,90
20**	31,80	42,50
21**	33,34	42,50
22**	35,00	42,50
24*	38,10	42,50

TABLE 3

CODE	MATERIAL / FINISH
1-C	ALUMINIUM / ELECTROLESS NICKEL
1-B	ALUMINIUM / CADMIUM OLIVE DRAB OVER ELECTROLESS NICKEL
1-ZB	ALUMINIUM / ZINC COBALT OLIVE DRAB OVER ELECTROLESS NICKEL
1-ZK	ALUMINIUM / ZINC COBALT BLACK OVER ELECTROLESS NICKEL
1-ZN	ALUMINIUM / ZINC NICKEL BLACK PASSIVATE OVER ELECTROLESS NICKEL
4-J	STAINLESS STEEL / PASSIVATE
2-Z	NICKEL ALUMINIUM BRONZE / SHOT BLAST

SEE SS0076 FOR FULL RANGE OF FINISH OPTIONS

TABLE 4



SUFFIX	MODIFICATION OPTIONS
-DB	DOUBLE BRAID
-N	NICKEL PLATED BRAID
-12	NON-STANDARD BRAID LENGTH (IN INCHES)

* - NOT AVAILABLE IN DB MODIFICATION

** - ADD 2,10 TO F MAX FOR DB MODIFICATION
ADD 0,80 TO ØH FOR DB MODIFICATION

70H1-17-08-1-C

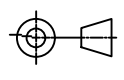
SERIES _____
 CONNECTOR INTERFACE _____
 ANGLE _____
 SHELL SIZE (TABLE 1) _____
 ENTRY SIZE (TABLE 2) _____
 MATERIAL AND FINISH (TABLE 3) _____
 BRAID TAIL MODIFICATION (SEE TABLE 4) _____
 OMIT FOR STANDARD (6 INCH SINGLE LAYER TINNED COPPER)

DRAWN		DATE		 3RD ANGLE PROJECTION NOT TO SCALE	PART NUMBER:				 70H SERIES			
K.WINCZURA		25/04/2018			TITLE:							
DESIGN APPROVAL		DATE		UNLESS OTHERWISE SPECIFIED ALL DIMENSIONS IN MILLIMETRES GENERAL TOL LINEAR +/-0,25MM ANGULAR +/- 1°					ASSY USED ON: MIL-CTL-38999 SERIES III & IV			
K.SHEPPARD		18/09/2013						MATERIAL SEE PART NUMBER BREAKDOWN FINISH SEE PART NUMBER BREAKDOWN				
DOC TYPE	Customer Drawing			POLAMCO LTD, WESTON LOCK, LOWER BRISTOL ROAD BATH BA2 1EP								SHT
ISSUE/REV	CA	DCR	6777					2		P29235		
NCAGE CODE U5792		WEIGHT N/A										